

TECHNICAL MANUAL UNIT MAINTENANCE

**CARRIER, PERSONNEL,
FULL TRACKED, ARMORED, M113A2
2350-01-068-4077**

**CARRIER, COMMAND POST,
LIGHT TRACKED, M577A2
2350-01-068-4089**

**CARRIER, MORTAR, 107-MM, M30;
SELF-PROPELLED, M106A2
2350-01-069-6931**

**CARRIER, MORTAR, 81-MM, M29A1;
SELF-PROPELLED, M125A2
2350-01-068-4087**

**CARRIER, MORTAR, 120-MM, M121;
SELF-PROPELLED, M1064
2350-01-338-3116**

**CARRIER, SMOKE GENERATOR,
FULL TRACKED, M1059
2350-01-203-0188**

**COMBAT VEHICLE, ANTI-TANK,
IMPROVED TOW VEHICLE, M901A1
2350-01-103-5641**

**CARRIER, STANDARDIZED INTEGRATED
COMMAND POST SYSTEM, M1068
2350-01-354-5657**

MAINTENANCE OF COOLING
SYSTEM

8-1

MAINTENANCE OF ELECTRICAL
SYSTEMS

CHAPTERS 9 THROUGH 17

MAINTENANCE OF POWER
PLANT COMPONENTS

CHAPTERS 18 THROUGH 21

MAINTENANCE OF TRACKS
AND SUSPENSION

22-1

MAINTENANCE OF DRIVER'S
CONTROLS

23-1

ALPHABETICAL INDEX

INDEX 1

This manual supersedes TM 9-2350-261-20-2 dated July 1985, including all changes.

DISTRIBUTION STATEMENT A:

Approved for public release; distribution is unlimited.

CHANGE
No. 4

HEADQUARTERS
DEPARTMENT OF THE ARMY
Washington, D.C., 15 July 1997

**TECHNICAL MANUAL
UNIT MAINTENANCE
FOR**

- CARRIER, PERSONNEL, FULL TRACKED, ARMORED, M113A2
2350-01-068-4077**
- CARRIER, COMMAND POST, LIGHT TRACKED, M577A2
2350-01-068-4089**
- CARRIER, MORTAR, 107-MM, M30; SELF-PROPELLED, M106A2
2350-01-069-6931**
- CARRIER, MORTAR, 81-MM, M29A1; SELF-PROPELLED, M125A2
2350-01-068-4087**
- CARRIER, MORTAR, 120-MM, M121; SELF-PROPELLED, M1064
2350-01-338-3116**
- CARRIER, SMOKE GENERATOR, FULL TRACKED, M1059
2350-01-203-0188**
- COMBAT VEHICLE, ANTI-TANK, IMPROVED TOW VEHICLE, M901A1
2350-01-103-5641**
- CARRIER, STANDARDIZED INTEGRATED COMMAND POST SYSTEM, M1068
2350-01-354-5657**

TM 9-2350-261-20-2, July 1990, is changed as follows:

1. Remove old pages and insert new pages as indicated below.
2. New or changed material is indicated by a vertical bar in the margin of the page.
3. Added or revised illustrations are indicated by a pointing hand adjacent to the illustration.

Remove Pages

g (h blank)
i thru iv.1 (iv.2 blank)
8-15 thru 8-18
8-41 thru 8-46
9-9 thru 9-12
9-39 thru 9-44
10-1 thru 10-4
11-7 and 11-8
12-55 and 12-56
12-75 and 12-76
15-1 and 15-2

Insert Pages

g (h blank)
i thru iv.1 (iv.2 blank)
8-15 thru 8-18
8-41 thru 8-46
9-9 thru 9-12
9-39 thru 9-44
10-1 thru 10-4
11-7 and 11-8
12-55 and 12-56
12-75 and 12-76
15-1 and 15-2

C 4

Remove Pager

None
17-17 thru 17-34

20-1 thru 20-8
21-1 and 21-2
21-17 and 21-20
None
22-23 and 22-24
22-29 thru 22-32
23-1 and 23-2
23-31 thru 23-32.1 (23-32.2 blank)
Index-1 thru Index-30
DA 2028-2 (Sample) and DA 2028-2
Sample Reverse)
DA 2028-2 and DA 2028-2 (Reverse)
DA 2023-2 and DA 2028-2 (Reverse)
DA 2028-2 and DA 2028-2 (Reverse)
Metric Chart Inside Back Cover
Cover 1 and 2

Insert Pages

15-7 thru 15-13 (15-14 blank)
17-17/(17-18 blank)(17-19 thru 17-34
deleted)
20-1 thru 20-8
21-1 and 21-2
21-17 and 21-20
21-23 and 21-24
22-23 and 22-24
22-29 thru 22-32
23-1 and 23-2
23-31 thru 23-32.1 (23-32.2 blank)
Index-1 thru Index-29 (Index-30 blank)
DA 2028-2 (Sample) and
DA 2028-2 (Sample Reverse)
DA 2028-2 and DA 2028-2 (Reverse)
DA 2028-2 and DA 2028-2 (Reverse)
DA 2028-2 and DA 2028-2 (Reverse)
Metric Chart Inside Back Cover
Cover 1 and 2

File this change sheet in front of the publication for reference purposes.

By Order of the Secretary of the Army:

DENNIS J. REIMER
General, United States Army
Chief of Staff

Official:

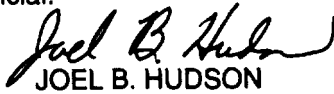
JOEL B. HUDSON

Administrative Assistant to the
Secretary of the Army
03778

DISTRIBUTION:

To be distributed in accordance with the initial distribution number (IDN) 371201 requirements
for TM 9-2350-261-20-2.

CHANGE
No. 3

HEADQUARTERS
DEPARTMENT OF THE ARMY
Washington D. C., 28 January 1994

**TECHNICAL MANUAL
UNIT MAINTENANCE
FOR**

**CARRIER, PERSONNEL, FULL TRACKED, ARMORED, M113A2
2350-01-068-4077**

**CARRIER, COMMAND POST, LIGHT TRACKED, M577A2
2350-01-068-4089**

**CARRIER, MORTAR, 107-MM, M30; SELF-PROPELLED, M106A2
2350-01-069-6931**

**CARRIER, MORTAR, 81-MM, M29A1; SELF-PROPELLED, M125A2
2350-01-068-4087**

**CHASSIS, GUN, ANTI-AIRCRAFT ARTILLERY, M741A1
2350-01-099-8929**

**CARRIER, SMOKE GENERATOR, FULL TRACKED, M1059
2350-01-203-0188**

**COMBAT VEHICLE, ANTI-TANK, IMPROVED TOW VEHICLE, M901A1
2350-01-103-5641**

**CARRIER, MORTAR, 120-MM, M121; SELF-PROPELLED, M1064
2350-01-338-3116**

**CARRIER, STANDARDIZED INTEGRATED COMMAND POST SYSTEM, M1068
2350-01-354-5657**

TM 9-2350-261-20-2, 11 July 1990, is changed as follows:

1. Title is changed to reflect added new item of equipment, Carrier, Standardized Integrated Command Post System, M1068.
2. Remove old pages and insert new pages as indicated below.
3. New or changed material is indicated by a vertical bar in the margin of the page.
4. Added or revised illustrations are indicated by a pointing hand adjacent to the illustration.

Remove Pages

e and f
i thru vi
xiii (xiv blank)
9-1 and 9-2
9-5 and 9-6
9-9 thru 9-16
9-21 and 9-22
9-25 thru 9-28
9-45 and 9-46
9-49 and 9-50
11-1 and 11-2
12-21 thru 12-24
12-55 and 12-56

Insert Pages

e, f, and g (h blank)
i thru vi (iv.2 blank)
xiii (xiv blank)
9-1 and 9-2
9-5 and 9-6
9-9 thru 9-16
9-21 and 9-22
9-25 thru 9-28
9-45 and 9-46
9-49 and 9-50
11-1 and 11-2
12-21 thru 12-24
12-55 and 12-56

DISTRIBUTION STATEMENT - Distribution authorized to U.S. Government agencies and their contractors for administrative and operational purposes only. This determination was made on 23 August 1989. Other requests for this document will be referred to: Commander, U.S. Army Tank-Automotive Command, ATTN AMSTA-MB, Warren, MI 48397-5000.
DESTRUCTION NOTICE - Destroy by any method that will prevent disclosure of contents or reconstruction of the document.

C3

Remove Pages

12-59 thru 12-78
12-81 and 12-82
12-85 and 12-86
12-93 and 12-94
12-99 and 12-100
13-1 and 13-2
None
13-13 and 13-14
13-35 and 13-36
14-1 and 14-2
14-11 (14-12 blank)
17-3 thru 17-18
21-19 thru 21-22
Index-1 thru Index-27 (Index-28 blank)
Cover

Insert Pages

12-59 thru 12-78
12-81 and 12-82
12-85 and 12-86
12-93 and 12-94
12-99 and 12-100
13-1 and 13-2
13-6.1 thru 13-6.6
13-13 and 13-14
13-35 and 13-36
14-1 and 14-2
14-11 (14-12 blank)
17-3 thru 17-18
21-19 thru 21-22
Index-1 thru Index-30
Cover

File this change sheet in front of the publication for reference purposes.

By Order of the Secretary of the Army:

Official:

GORDON R. SULLIVAN
General, United States Army
Chief of Staff

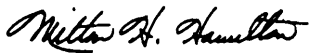
MILTON H. HAMILTON
Administrative Assistant to the
Secretary of the Army
06065

Distribution:

To be distributed in accordance with DA Form 12-37-E (Block 1201) Unit Maintenance requirements for TM 9-2350-261-20-2.

CHANGE
No. 2

HEADQUARTERS
DEPARTMENT OF THE ARMY
Washington D. C., 4 March 1992

**TECHNICAL MANUAL
UNIT MAINTENANCE
FOR**

**CARRIER, PERSONNEL, FULL TRACKED, ARMORED M113A2
2350-01-068-4077**

**CARRIER, COMMAND POST, LIGHT TRACKED, M577A2
2350-01-068-4089**

**CARRIER, MORTAR, 107-MM, M30; SELF-PROPELLED, M106A2
2350-01-069-6931**

**CARRIER, MORTAR, 81-MM, M29A1; SELF-PROPELLED, M125A2
2350-01-068-4087**

**CARRIER, MORTAR, 120-MM, M121; SELF-PROPELLED, M1064
2350-01-338-3116**

**CHASSIS, GUN, ANTI-AIRCRAFT ARTILLERY, M741A1
2350-01-099-8929**

**CARRIER, SMOKE GENERATOR, FULL TRACKED, M1059
2350-01-203-0188**

**COMBAT VEHICLE, ANTI-TANK,
IMPROVED TOW VEHICLE, M901A1
2350-01-103-5641**

TM 9-2350-261-20-2, July 1990, is changed as follows:

1. Remove old pages and insert new pages as indicated below.
2. New or changed material is indicated by a vertical bar in the margin of the page.
3. Added or revised illustrations are indicated by a pointing hand adjacent to the illustration.

Remove Pages

i thru vi
xiii (xiv blank)
a and b
e and f
11-1 and 11-2
11-19 and 11-20

Insert Pages

i thru vi
xiii (xiv blank)
a and b
e and f
11-1 and 11-2
11-19 and 11-20

DISTRIBUTION STATEMENT C. Distribution authorized to U.S. Government agencies and their contractors for administrative and operational purpose only. This determination was made on 23 August 1989. Other requests for this document will be referred to: Commander, U.S. Army Tank-Automotive Command, ATTN: AMSTA-MB, Warren, MI

Destruction Notice - Destroy by any method that will prevent disclosure of contents or reconstruction of the document.

C2

Remove Pages

12-21 and 12-22
12-43 and 12-44
12-47 and 12-48
12-51 and 12-52
12-55 thru 12-60
12-77 and 12-78
None
13-1 and 13-2
13-9 and 13-10
13-17 thru 13-20
13-23 thru 13-28
13-31 and 13-32
16-7 thru 16-10
22-35 thru 22-37 (22-38 blank)
Index 1 thru Index 27 (Index 28 blank)

Insert Pages

12-21 and 12-22
12-43 and 12-44
12-47 and 12-48
12-51 and 12-52
12-55 thru 12-60
12-77 and 12-78
12-118.1 thru 12-118.20
13-1 and 13-2
13-9 and 13-10
13-17 thru 13-20
13-23 thru 13-28
13-31 and 13-32
16-7 thru 16-10
22-35 thru 22-37 (22-38 blank)
Index 1 thru Index 28

File this change sheet in front of the publication for reference purposes.

By Order of the Secretary of the Army:

Official:

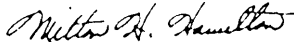

MILTON H. HAMILTON
*Administrative Assistant to the
Secretary of the Army*

00530

GORDON R. SULLIVAN
*General, United States Army
Chief of Staff*

Distribution:

To be distributed in accordance with DA Form 12-37-E, Block 1201, Unit maintenance requirements for TM 9-2350-261-20-2.

C1

CHANGE
No. 1HEADQUARTERS
DEPARTMENT OF THE ARMY
Washington D. C., 30 July 1991**TECHNICAL MANUAL
UNIT MAINTENANCE
FOR**

**CARRIER, PERSONNEL, FULL TRACKED, ARMORED, M113A2
2350-01-068-4077**

**CARRIER, COMMAND POST, LIGHT TRACKED, M577A2
2350-01-068-4089**

**CARRIER, MORTAR, 107-MM, M30; SELF-PROPELLED, M106A2
2350-01-069-6931**

**CARRIER, MORTAR, 81-MM, M29A1; SELF-PROPELLED, M125A2
2350-01-068-4087**

**CHASSIS, GUN, ANTI-AIRCRAFT ARTILLERY, M741A1
2350-01-099-8929**

**CARRIER, SMOKE GENERATOR, FULL TRACKED, M1059
2350-01-203-0188**

**COMBAT VEHICLE, ANTI-TANK, IMPROVED TOW VEHICLE, M901A1
2350-01-103-5641**

TM 9-2350-261-20-2, July 1990, is changed as follows:

1. Remove old pages and insert new pages as indicated below.
2. New or changed material is indicated by a vertical bar in the margin of the page.
3. Added or revised illustrations are indicated by a pointing hand adjacent to the illustration.

Remove Pages

9-33 thru 9-44
12-131 thru 12-138
21-17 thru 21-20
22-11 thru 22-14
22-25 thru 22-28
23-31 and 23-32
None
23-33 thru 23-46
Index-1 thru Index-27 (Index-28 blank)

Insert Pages

9-33 thru 9-44
12-131 thru 12-138
21-17 thru 21-20
22-11 thru 22-14
22-25 thru 22-28
23-31 and 23-32
23-32.1 (23-32.2 blank)
23-33 thru 23-46
Index-1 thru Index-28

File this change sheet in front of the publication for reference purposes.

C1

By Order of the Secretary of the Army:

Official:

GORDON R. SULLIVAN
General, United States Army
Chief of Staff

PATRICIA P. HICKERSON
Brigadier General, United States Army
The Adjutant General

Distribution:

To be distributed in accordance with DA Form 12-37-E (Block 1201) Unit Maintenance requirements for TM 9-2350-261-20-2.

SUMMARY OF WARNINGS

WARNING

This list summarizes critical **WARNINGS** in this manual. They are repeated here to let you know how important they are. Study these **WARNINGS** carefully; they can save your life and the lives of personnel with whom you work.

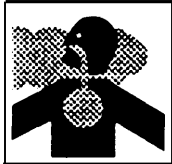

WARNING
Dry cleaning solvent P-D-680 is toxic and flammable. Wear protective goggles and gloves; use only in well-ventilated area; avoid contact with skin, eyes, and clothes, and do not breathe vapors. Keep away from heat or flame. Never smoke when using solvent; the flash point for type I dry cleaning solvent is 100°F (38°C) and for type II is 138°F (50°C). Failure to do so may result in injury or death to personnel.

If personnel become dizzy while using cleaning solvent, immediately get fresh air and medical help. If solvent contacts skin or clothes, flush with cold water. If solvent contacts eyes immediately flush eyes with water and get immediate medical attention.



WARNING
Unlocked ramp can open and move down slowly. If ramp system is damaged, unlocked ramp can fall suddenly. Personnel can be killed or injured. Take care when you work near ramp. Keep away from ramp that has come open during carrier operation.



WARNING
Energized systems and equipment can bum you. If MASTER SWITCH is ON, electrical system and equipment will be energized. Make sure MASTER SWITCH is OFF when you work on electrical systems or equipment.



WARNING
Failure to set the parking brake and block the road wheels can allow the carrier to move and could result in injury or death. Always set the parking brake and block road wheels before working on the carrier.



WARNING
Battery post and cables touched by metal objects can short circuit and bum you. Gas from batteries can explode and injure you. Battery acid can blind you or bum you. Do not wear jewelry when you work on electrical systems. Use caution when you work near battery or electrical system with tools or other metal objects. Do not get acid on your skin or in your eyes. Do not allow sparks near batteries.

WARNING



Heater and engine exhaust can kill or poison you. Close power plant access panels tight before you start engine. Do not run heater or engine indoors without very good fresh air flow. Keep power plant access cover closed when you run engine. Check for the smell of exhaust fumes. If you notice any fumes, open hatches and turn on vent fans.

WARNING

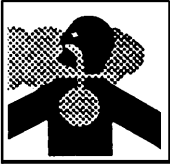

Exhaust gases can make you ill or kill you. Signs of exhaust gas poison are dizziness, headache, loss of muscle control, sleepiness, coma, or death. If anyone shows signs of exhaust gas poisoning. Get all personnel out of carrier. Get medical help. Make sure personnel have lots of fresh air. Keep personnel warm. Do not let anyone do hard exercise. If anyone stops breathing, give artificial respiration.

WARNING



Torsion springs or bars can fly out and injure you. Make sure spring tension is released before you start work.

WARNING

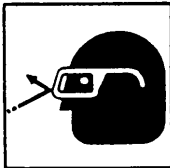

Air pressure in excess of 30 psi (207 kpa) can injure personnel. Do not direct pressurized air at yourself or others. Always wear goggles.

WARNING



If you work on a carrier that has been running, you could be burned. All tasks begin with a cooled down carrier. Allow carrier to cool, or use care if you work on a hot carrier.

WARNING



Unsafe use of chemical products, tools, and equipment can injure you. Read and follow warnings and instructions on labels of all chemical products. Follow all general shop safety procedures. See unit commander for further instructions on safety.

WARNING



Fire bottles can discharge and injure you. Insert antirecoil plugs, lock pins, and cotter pins before you work on or near fire bottles.

WARNING



Hanging loads could kill or injure you. Keep away from hanging loads and overhead equipment. Keep hands out of engine compartment while power unit is being removed or installed.

WARNING

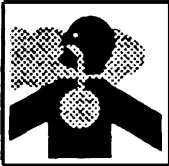

NBC agents can kill you. Do not service air cleaner or vent system after NBC attack until earner has been decontaminated.

WARNING



Starting engine right after a fire could restart the fire and kill or injure you. Do not turn MASTER SWITCH ON until cause of fire has been repaired or removed.

WARNING



Loctite sealing compound can damage your eyes. Before you handle loctite sealing compound, wear safety glasse/goggles, avoid contact with eyes. If it gets into your eyes, flush eyes with fresh water and get medical help.

WARNING



Remove machine gun and all ammunition when operating M113A2 as a litter carrier. Display Red Cross symbol on exterior of carrier.

WARNING



To prevent litter tilt, which could cause injury, be sure to install repair link at chain link.

WARNING



Loose clothing is dangerous around moving belts and pulleys. You could get badly hurt if your clothes get caught in moving parts.

WARNING



Hot radiator coolant can burn you. Use hand to remove cap **ONLY** if cool to touch. Turn cap slowly to release pressure. Replace cap by pressing down and turning until tight.

WARNING



Radiator is heavy and can cause back injury if handled improperly. Be sure to use a hoist and helper to remove radiator.

WARNING



Do not work under power plant. Power plant is heavy and may cause personnel and equipment damage if it falls. Lower power plant close to the ground before starting task.

WARNING



Carbon Monoxide is poisonous and can kill you. Do not idle engine with driver's power plant access panel off unless there is very good air flow.

WARNING

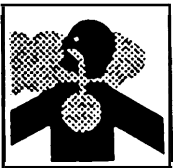

Carbon Monoxide gas is deadly poison. Play it safe: make sure power plant access covers and door are closed tight before you start engine.

WARNING



Damaged lifting slings can fail with load. Soldiers can be killed or injured. Inspect all slings before use. Do not use damaged slings.

WARNING

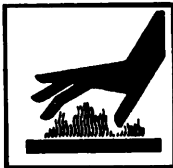

Do not touch exhaust pipes with bare hands. You could get a bad burn.

WARNING



Gas from batteries can explode. Ventilate compartment before you disconnect or connect battery cables. Battery acid can burn or blind you. Do not get acid on your skin or eyes. ALWAYS disconnect negative (circuit 7) lead first and connect it last.

WARNING



Battery posts and cables touched by metal objects can short circuit and burn you or injure you. Use caution when you work with tools or other metal objects. Do not wear jewelry when you work on electrical system.

WARNING

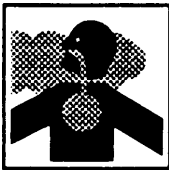

Fuel and fog oil can burn and could poison you.

WARNING



Fog oil is slippery and can cause soldiers to fall and get injured. Clean up all spillage or leakage of fog oil as soon as possible by washing the area or absorbing the fog oil with sand or other absorbent material.

WARNING



You could be killed or injured by accidental carrier movement. Before you perform maintenance, make sure to properly block the carrier.

WARNING



Hanging loads can kill or injure you. Keep away from hanging loads and overhead equipment. Keep hands away from pinch points.

WARNING



Lifting or moving objects in excess of 70 pounds could injure you. Make sure to get an assistant or use a lifting device to move fog oil tank, armor, or other heavy objects.

WARNING

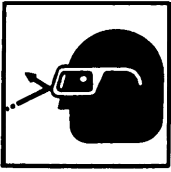

Compressed air pressure from smoke generator can cause serious injury or death. To avoid accidents, bleed air before working on air compressor assembly or disconnecting any air hose.

WARNING



Fire resistant hydraulic (FRH) fluid may contain Tricresyl Phosphate which, if taken internally, can produce paralysis. Hydraulic fluid may be absorbed through the skin. Wear long sleeves, gloves, goggles, and face shield. If FRH gets in eyes, wash them immediately and get medical aid immediately. If FRH gets on your skin, thoroughly wash with soap and water. Wash hands thoroughly prior to eating or smoking.

WARNING



Chemical Agent Resistance Coatings (CARC) are toxic. Use a respirator when spraying or brushing CARC. To identify the needed respirator and detailed safety information, consult your environmental or safety office before using CARC. Protect your hands and wrists with rubber gloves. Wear coveralls. Keep your eyes protected with splash goggles or face shield. Never mix paint or use thinner near an open flame during painting and for at least four to six hours afterward. Make sure the temperature of the surface to be painted is not less than 60°F and no more than 100°F. One person is not to use more than one quart of CARC a day. Two people will not paint an item at the same time.

WARNING



Vehicle operation during hot weather may result in potential heat stress to crew members. Crew members should limit their exposure based on TB med 507 using PHEL Chart (Appendix C) curve as a guide.

WARNING



Start up of equipment or moving parts could injure you or others. If other personnel are working on your carrier, be sure you know what they are doing. Place **DO NOT OPERATE** tags on **MASTER SWITCH** when needed to prevent startup.

WARNING



Power cable connections should not be attempted until grounding system and signal/data cabling have been completed.

System ground must be completed prior to making any power connections. Failure to do so may result in personal injury and/or damage to the equipment.

Improper or loose connection between the surface wire grounding systems and ground lugs could cause a short in the system, which may cause personal injury.

WARNING



HIGH VOLTAGE is used in the operation of this equipment.

DEATH ON CONTACT may result if personnel fail to observe safety precautions.

NEVER work on equipment unless at least one other person familiar with the operation and hazards of the equipment is nearby. That person should also be competent in giving first aid. When an operator helps a technician, that operator must be warned about dangerous areas.

SHUT. OFF POWER supply to equipment before beginning work. When working inside equipment with power off, take special care to ground every capacitor likely to hold a dangerous potential.

BE CAREFUL not to contact high-voltage connections when installing or operating this equipment.

KEEP one hand away from the equipment to reduce the hazard of current flowing through life-sustaining organs of the body.

WARNING



The insulator blanket is made out of asbestos. Handle with care. Discard insulator blanket properly as a hazardous material per local standard operating procedure. The insulator washer takes the place of the blanket.

Technical Manual

No. 9-2350-261-20-2

HEADQUARTERS
DEPARTMENT OF THE ARMY

Washington, D.C., 11 July 1990

**TECHNICAL MANUAL
UNIT MAINTENANCE**

**CARRIER, PERSONNEL, FULL TRACKED, ARMORED, M113A2
2350-01-068-4077**

**CARRIER, COMMAND POST, LIGHT TRACKED, M577A2
2350-01-068-4089**

**CARRIER, MORTAR, 107-MM, M30; SELF-PROPELLED, M106A2
2350-01-069-6931**

**CARRIER, MORTAR, 81-MM, M29A1; SELF-PROPELLED, M125A2
2350-01-068-4087**

**CARRIER, MORTAR, 120-MM, M121; SELF-PROPELLED, M1064
2350-01-338-3116**

**CARRIER, SMOKE GENERATOR, FULL TRACKED, M1059
2350-01-203-0188**

**COMBAT VEHICLE, ANTI-TANK, IMPROVED TOW VEHICLE, M901A1
2350-01-103-5641**

**CARRIER. STANDARDIZED INTEGRATED COMMAND POST SYSTEM, M1068
2350-01-345-5657**

REPORTING ERRORS AND RECOMMENDING IMPROVEMENTS

You can help improve this manual. If you find any mistakes, or if you know a way to improve the procedures, please let us know. Mail your letter, DA Form 2028 (Recommended Changes to Publications and Blank Forms), or DA Form 2028-2 located in the back of this manual, directly to: Commander, U.S. Army Tank-automotive and Armaments Command, ATTN:AMSTA-AC-NML, Rock Island, IL 61201-9948. A reply will be furnished to you.

This manual supersedes TM 9-2350-261-20 dated July, 1985, including all changes.

DISTRIBUTION STATEMENT A:
Approved for public release; distribution is unlimited.

TABLE OF CONTENTS

HOW TO USE THIS MANUAL..... vi

CHAPTER	1	INTRODUCTION	1-1
Section	I	General Information.....	1-1
	II	Equipment Description and Data.....	1-12
CHAPTER	2	PRINCIPLES OF OPERATION.....	2-1
Section	I	Integrated systems.....	2 - 1
	II	Integrated Components	2 - 8
	III	Service Upon Receipt of Material.....	2-24
	IV	General Maintenance Procedures	2-27
	V	Unit Preventive Maintenance Checks and Services (PMCS).....	2-39
CHAPTER	3	GENERAL TROUBLESHOOTINGPROCEDURES.....	3-1
Section	I	How to Use Troubleshooting.....	3 - 1
	II	Troubleshooting	3 - B
	III	STE/ICE-R Troubleshooting.....	3-236.1
CHAPTER	4	ENGINE-RELATED COMPONENTS MAINTENANCE.....	4-1
CHAPTER	5	POWER PLANT MAINTENANCE.....	5-1
CHAPTER	6	FUEL SYSTEM MAINTENANCE	6-1
Section	I	Fuel System Hose Replacement, Diagrams, and Tests.....	6-1
	II	Inside Fuel Tank and Hoses, Tubes, and Fittings (M113A2, M1059, M577A2, and M901A1 only)	6-4
	III	External Fuel Tanks and Hoses, Tubes, and Fittings (M981 and M1064 Only).....	6-27
	IV	Sponson Mounted Fuel Tanks and Lines (M577A2 Only)	6-49
	V	Fuel Compartment and Hoses, Tubes and Fittings (M125A2 and M106A2 Only)	6-76
	VI	Fuel Compartment, Bladder, Hoses, Tubes, and Fittings (M741A1 Only).....	6-87
	VII	Bulkhead to Injectors Engine Fuel and Air Hoses.	6-101
	VIII	Fuel System Components.....	6-120
CHAPTER	7	AIR INDUCTION AND EXHAUST SYSTEM MAINTENANCE	7-1
Section	I	Air Induction System	7-1
	II	Engine Exhaust System	7-15
CHAPTER	8	COOLING SYSTEM MAINTENANCE.....	8-1
SECTION	I	Engine Coolant Pump, Radiator, and Tubes.....	8-1
	II	Fan and Drive Components	8-34

CHAPTER	9 ELECTRICAL SYSTEM MAINTENANCE - POWER RECEPTACLES, GENERATOR, AND REGULATOR.....	9-1
Section	I Auxiliary Power Receptacles.....	9-1
	II Maintenance of Master Switch Panel Assembly.....	9-12
	III Maintenance of Generator, Regulator, and Circuit 49 Lead Wire Assemblies.....	9-28
CHAPTER	10 STARTER SYSTEM MAINTENANCE	10-1
CHAPTER	11 ELECTRICAL SYSTEM MAINTENANCE - INSTRUMENT AND WARNING LIGHT PANELS	11-1
Section	I Instrument Panel.....	11-1
	II Warning Light Panel.....	11-21
CHAPTER	12 ELECTRICAL SYSTEM MAINTENANCE - HORN AND LIGHTING SYSTEM	12-1
Section	I Horn and Exterior Lights	12-1
	II Maintenance of Wiring Harness (M741A1 Only).....	12-15
	III Maintenance of Distribution Box	12-22
	IV Maintenance of Stop Light, Dome Lights Buzzer and Door Switches, and Tent Light	12-56
	V Maintenance of Wiring Harness	12-78
	VI Maintenance of Stop Light Switch and Infrared Power Supply	12-131
CHAPTER	13 ELECTRICAL SYSTEM MAINTENANCE - BATTERIES.....	13-1
CHAPTER	14 ELECTRICAL SYSTEM MAINTENANCE - WIRING HARNESS, RECEPTACLE, AND CABLE REPAIR	14-1
CHAPTER	15 ELECTRICAL SYSTEM MAINTENANCE - POWER PLANT WIRING HARNESS AND RELATED COMPONENTS.....	15-1
CHAPTER	16 ELECTRICAL SYSTEM MAINTENANCE - BILGE PUMP, WIRING, AND RELATED COMPONENTS.....	16-1
CHAPTER	17 TRAILER HARNESS, RECEPTACLES, BLOWER, SWITCHES, AND VENTILATION SYSTEM MAINTENANCE.....	17-1
Section	I Trailer Harness	17-1
	II Communication and Utility Receptacles	17-4
	III Rear Compartment Blower and Fuel Quantity Selector Switch (M577A2 Only)	17-14
	IV Deleted	17-18
CHAPTER	18 TRANSMISSION RELATED COMPONENTS MAINTENANCE.....	18-1
CHAPTER	19 TRANSFER GEARCASE-RELATED COMPONENTS	19-1
CHAPTER	20 DRIVE SHAFTS, UNIVERSAL JOINTS, AND FINAL DRIVE MAINTENANCE.....	20-1

CHAPTER	21	DIFFERENTIAL RELATED COMPONENTS MAINTENANCE	21-1
CHAPTER	22	TRACKS AND SUSPENSION MAINTENANCE	22-1
CHAPTER	23	DRIVER'S CONTROLS	23-1
Section	I	Steering Controls	23-1
	II	Accelerator and Transmission Linkage, Throttle Linkage, and Fuel Cutoff Cable	23-21
	III	Transmission Controls and Engine Power Disconnect	23-47
	IV	Pivot Steer and Controls	23-60
CHAPTER	24	HULL MAINTENANCE	24-1
Section	I	Lifting Eyes, Towing Eyes, Pintle, and Tow Rope Stowage Pads	24-1
	II	Trim Vane, Power Plant Front Door, and Power Plant Access Door	24-7
	III	Hull Bottom Covers, Drain Plugs, and Box Beam Plugs	24-31
	IV	Driver's and Rear Compartment Floor Plates	24-36
	V	Grill Assembly, Top Deck Hatches, Ventilator, and Generator Set Enclosure	24-48
	VI	Armor and Support Maintenance (M901A1 Only)	24-119
	VII	Driver's Seat and Commander's Seat Platform (All Configurations)	24-126
	VIII	Personnel Seats- Rear Compartment	24-162
	IX	Blackout Curtain and Tables (M577A2, M1068, and M901A1 Only)	24-170
	X	Tent and Frame	24-181
	XI	Ammunition and Fuze Racks (M106A2, M1064, and M125A2 Only)	24-185
	XII	Ammunition Containers and Components (M741A1 Only)	24-194
	XIII	Turret Guard, Gun Travel Lock, and Flotation Pods (M741A1 Only)	24-209
	XIV	Dataplates, Stencils, Markers, Decals, and Miscellaneous Stowage Items	24-216
	XV	Stowage System Maintenance	24-264
	XVI	Antenna Mast Maintenance	24-276
CHAPTER	25	RAMP CONTROLS, RAMP, AND RAMP DOOR MAINTENANCE	25-1
CHAPTER	26	WELDING — CAUTIONS, WARNINGS, AND INSTRUCTIONS.	26-1
CHAPTER	27	SMOKE GRENADE LAUNCHER AND AMMUNITION SPACERS	27-1
CHAPTER	28	HYDRAULIC SYSTEM — RAMP AND SUSPENSION LOCKOUT.	28-1
Section	I	Hydraulic Tank, Valves, and Lines (All Except M741A1)	28-1
	II	Hydraulic Tank, Valves, and Lines (M741A1 Only).	28-24
	III	Suspension Lockout System (M741A1 Only)	28-47
	IV	Ramp Pump, Ramp Control Valve, and Ramp Cylinder	28-80
CHAPTER	28.1	AUXILIARY GENERATOR	28.1-1
CHAPTER	29	PERSONNEL HEATER KIT COMPONENT MAINTENANCE.	29-1
CHAPTER	30	DRIVER'S WINDSHIELD KIT	30-1

CHAPTER	31	ELECTRONIC EQUIPMENT HEATER KIT (M577A2 Only).....	31-1
Section		I Heater Component Maintenance	
		(Stewart Warner Corp., Model 10560M24B1)	31-1
		II Heater Component Maintenance (Hupp Corp., Model MF510B).....	31-1
		III Electronic Equipment Heater.....	31-2
CHAPTER	32	ENGINE COOLANT HEATER KIT	32-1
Section		I Description and Data	32-1
		II Coolant Heater Component Maintenance	32-3
		III Kit Component Maintenance - Engine Coolant Heater	32-9
CHAPTER	33	RAMP NON-SKID WINTERIZATION KIT MAINTENANCE	
		(M106A2, M125A2, and M1064 Only)	33-1
CHAPTER	34	CAPSTAN KIT (M113A2 and M1059 Only)	34-1
CHAPTER	35	MARINE RECOVERY KIT (M113A2 and M1059 Only)	35-1
CHAPTER	36	LITTER KIT MAINTENANCE (M113A2 Only)	36-1
CHAPTER	37	ARTILLERY COMMUNICATION KITS (M577A2 Only).....	37-1
Section		I Deleted	37-1
		II Artillery Communication Kit M577A2 Only).....	37-5
CHAPTER	38	MACHINE GUN ARMOR SHIELD KIT MAINTENANCE.....	38-1
CHAPTER	39	NBC KIT MAINTENANCE (ALL VEHICLES EXCEPT M10641	39-1
Section		I NBC Kits (All vehicles except M1064 and M981)	39-1
Section		II Ventilation System Maintenance (M981 Only)	39-9
CHAPTER	40	SMOKE GENERATOR EQUIPMENT MAINTENANCE (M1059 Only) . . .	40-1
CHAPTER	40.1	ELECTRICAL/COMMUNICATION EQUIPMENT MAINTENANCE (M1068	
		Only)	40.1-1
Section		I Curbside Electrical/Communication Equipment (M1068 Only).....	40.1-1
Section		II Roadside Electrical/Communication Equipment (M1068 Only).....	40.1-25
Section		III Electrical/Communication Equipment Cables (M1068 Only)	40.1-57
CHAPTER	41	COMMUNICATION SYSTEM MAINTENANCE.....	41-1
CHAPTER	42	FIXED FIRE EXTINGUISHER SYSTEM MAINTENANCE.....	42-1
CHAPTER	43	DELETED	43-1
CHAPTER	44	CHEMICAL AGENT AUTOMATIC ALARM KIT (M113A2 Only)	44-1

APPENDIX	A. REFERENCES.....	A-1	
APPENDIX	B. MAINTENANCE ALLOCATION CHART	B-1	
Section	I Introduction	B-1	
	II Maintenance Allocation Chart.....	B-4	
	III Tools and Test Equipment Requirements	B-14	
	IV Remarks	B-21	
APPENDIX	C. EXPENDABLE/DURABLE SUPPLIES AND MATERIALS LIST	C-1	■
Section	I Introduction	C-1	
	II Expendable/Durable Supplies and Materials List	C-3	
APPENDIX	D. COMMON TOOLS AND SUPPLEMENTS AND		■
	SPECIAL TOOL/FIXTURES LIST	D-1	
Section	I Introduction.....	D-1	
	II Common Tools and Supplements and Special Tools/Fixtures List	D-3	
APPENDIX	E. FABRICATED TOOLS	E-1	■
	ALPHABETICAL INDEX	I-1	
	DA FORM 2028	Behind Index	
	WIRING DIAGRAMS.....	FO-1 thru FO-11	■
	METRIC CONVERSION CHART	Inside Back Cover	

HOW TO USE THIS MANUAL

This manual tells you how to perform unit maintenance for the M113A2, M106A2, M125A2, M577A2, M741A1, M1059, M1064, M1068, and M901A1 Carriers.

Before starting a task or procedure, read HOW TO USE THIS MANUAL and CHAPTER 2, PRINCIPLES OF OPERATION.

USING YOUR MANUAL ON THE JOB

The best way to learn about this manual is to practice using it. Knowing how to use this manual will save both time and energy.

WHICH TYPE OF TASK DO YOU USE?

There are two different types of tasks in this manual. They are maintenance tasks and troubleshooting tasks. Decide which type of task you need to use.

TROUBLESHOOTING TASKS

Troubleshooting tasks help you locate faulty parts. They direct you to the maintenance task to correct these faults. CHAPTER 3, TROUBLESHOOTING, contains detailed information on how to perform troubleshooting tasks. Read CHAPTER 3, Section I, before performing the troubleshooting tasks in the chapter.

MAINTENANCE TASKS

Doing maintenance tasks will keep the carrier in shape to operate. Maintenance tasks are used to present maintenance instructions. Each maintenance task details steps which you need to perform. If the vehicle and parts need maintenance that is not included in any task in the manual, report this to your supervisor.

HOW DO YOU FIND THE CORRECT TASK?

Pick a key word from the carrier part or system to be used during the task. Look in the ALPHABETICAL INDEX for this key word or the name of the action you will perform. Turn to the page indicated.

The ALPHABETICAL INDEX lists each task under one or more headings. The task, REPLACE TOWING PINTLE, could be found:

Under "P"

Pintle, towing:

Repair: 24-4

Under "T"

Towing pintle:

Repair: 24-4

HOW DO YOU READ MAINTENANCE TASKS?

Be sure to read all warnings, cautions, and notes. These are in all types of tasks. They help you avoid harm to yourself, other personnel and equipment. They also tell you things you should know about the task.

HOW TO USE THE REPAIR PARTS AND SPECIAL TOOLS LIST (RPSTL) WITH THIS MANUAL

The RPSTL (TM 9-2350-261-24P) gives the National Stock Number NSN required to order parts used in the maintenance tasks. To use the RPSTL to identify and order a part, do the following:

1. In this manual, turn to the first page of the task to be performed.
2. Find Materials/Parts under INITIAL SETUP, and read the part(s) that need replacement. If required, find the illustrated part in the task steps.
3. Go to the RPSTL and find the same illustrated part. That part will have an item number assigned to it. Look this item number up in the listing for that figure. The NSN can be found in the NSN column.
4. If you inspect an item and find that it is damaged, go to the RPSTL and find the SMR code for the item. If the SMR code does not authorize you to repair the item, reassemble it and send it to the authorized level of maintenance.
5. The usable on code in the RPSTL appears in the lower left corner of the Description column heading. Usable encodes are shown as 'UOC ' in the Description Column (justified left) on the first line following the item description/homenclature. Uncoded items are applicable to all models. Identification of the usable on codes in the RPSTL are:

Code	Used On
V35	M113A2 Carrier, Personnel
V36	M125A2 Carrier, 81 mm Mortar
V37	M577A2 Carrier, Command Post
V38	M106A2 Carrier, 107 mm Mortar
V83	M981 Carrier, Personnel, Armored Fire Support
V95	M741A1 Chassis, 20 mm Anti-Aircraft Gun
011	M901A1 Combat Vehicle, Anti-Tank Improved TOW Vehicle
056	M1059 Carrier, Personnel, Smoke
120	M1064 Carrier, 120 mm Mortar
ACP	M1068 Carrier, Standardized Integrated Command Post System

**CHAPTER 8
COOLING SYSTEM MAINTENANCE**

Section I. ENGINE COOLANT PUMP, RADIATOR, AND TUBES

TASK INDEX

<u>Task</u>	<u>Page</u>	<u>Task</u>	<u>Page</u>
Coolant Flow Diagram	8-2	Replace Thermostat Housing to Engine Coolant Tube	8-18
Drain Coolant System	8-3	Replace Radiator and Parts	8-20
Fill Cooling System	8-5	Replace Balance Hose	8-24
Clean Radiator	8-7	Repair Radiator Access Door Seals and Fasteners	8-25
Replace Engine Coolant Pump Idler Pulley and Belts	8-9	Repair Radiator Access Door	8-27
Replace Engine Coolant Pump	8-11	Replace Auxiliary Tank and Parts	8-28
Replace Deaeration Elbow to Radiator Inlet Elbow Coolant Tube	8-12	Replace Auxiliary Tank to Coolant Pump Tube	8-30
Replace Radiator Outlet Elbow to Coolant Pump Elbow Hose and Tube	8-14	Replace Auxiliary Tank to Radiator Tube	8-31
Replace Thermostat, Housing, and Deaeration Elbow	8-15	Replace Auxiliary Tank Deaeration Hoses	8-32
		Replace Combat Filler Cover and Lock	8-33

COOLANT FLOW DIAGRAM

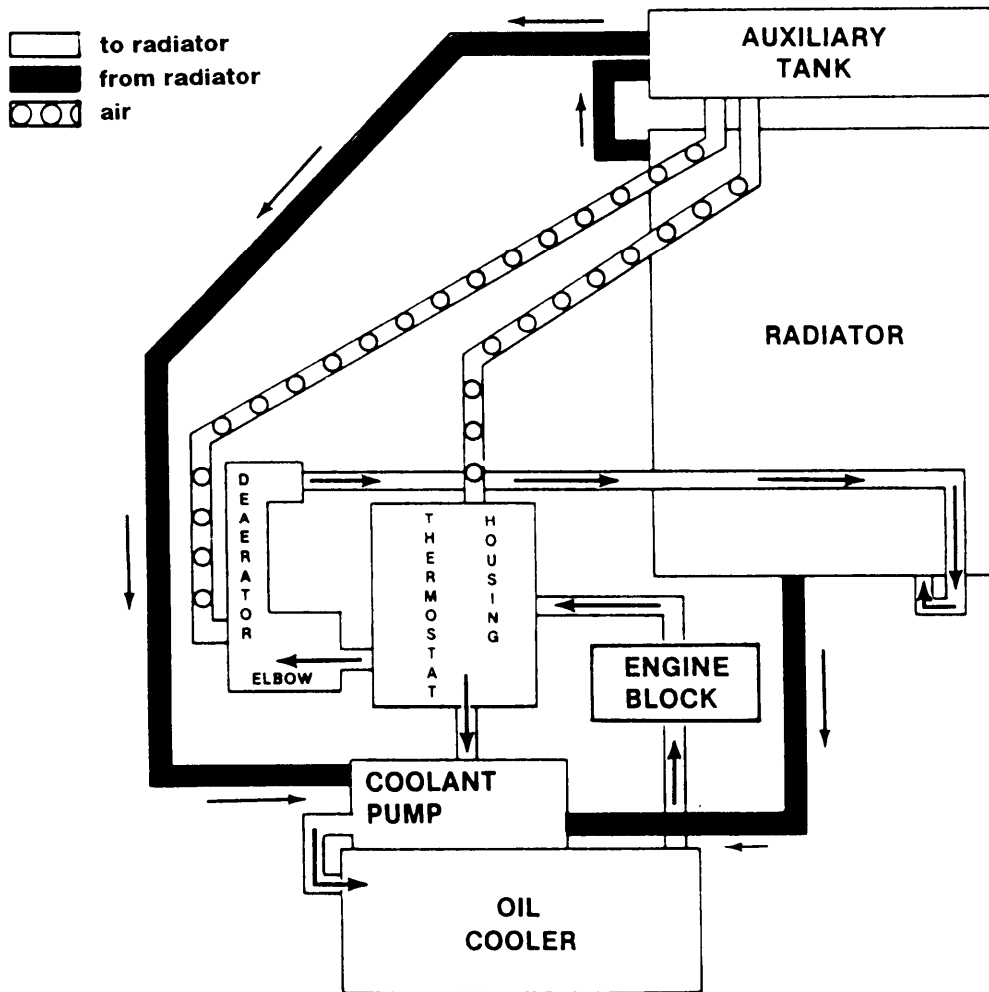

Engine coolant maintains normal operating temperatures. Coolant flow is as follows:

Coolant is drawn from the radiator by the coolant pump. It is pumped through the oil cooler, and the engine block, up to the cylinder heads, and into the thermostat housing. The coolant then passes through a deaerator elbow and back to the radiator. The deaerator elbow swirls the coolant to remove air. This air is vented back to the auxiliary tank.

The auxiliary tank provides for coolant overflow from the radiator. The tank also vents air out through its cap.

DRAIN COOLANT SYSTEM

INITIAL SETUP

Tools:

General Mechanics Tool Kit (Item 30, App D)

Materials/Parts:

Suitable container

Personnel Required:

Unit Mechanic

References:

See your -10

Equipment Conditions:

Engine stopped/shutdown (see your -10)
 Carrier blocked (see your -10)
 Trim vane lowered and power plant front access door open (see your - 10)
 Hull bottom access cover removed (page 24-32)
 Driver's power plant access panel removed (page 24-25)
 Power plant rear access panel removed (page 24-27 or 24-29)

DRAIN



WARNING

Hot radiator coolant can burn you. Remove cap only if cool to touch. Drain cocks may be hot. Turn cap slowly to release pressure. Replace cap by pressing down and turning until tight.

down and

CAUTION

Coolant in the cooling system must flow freely. If rust, scale, or sediment prevent the free flow of coolant, flush system per TB 750-651. This is to be done only as necessary. Do not operate engine above 230°F (110°C). Serious engine damage can result.

NOTE

For partial drain, attach a length of 1/2 inch (13mm) hose to the drain cock on thermostat housing or on deaerator elbow. Drain coolant into a clean container. Save coolant for reuse. Close drain cock.

GO TO NEXT PAGE



WARNING
Hot radiator coolant can burn you. Drain cocks may be hot. Remove cap only if cool to touch.

1. Remove coolant filler cap (1) slowly to relieve pressure.
2. Place clean containers under drain cocks (2, 3, 4, and 5).
3. Open oil cooler drain cock (4).
4. Open three engine block drains cocks. One cock (3) is on left side of block. The other two cocks (2) are on right side.
5. Open thermostat and deaerator elbow drain cocks (5). Allow system to drain.
6. After system is drained, close six drain cocks (2, 3, 4, and 5). Replace filler cap (1).
7. Tag master switch to warn others that engine coolant has been drained.
8. Save coolant for reuse, unless check shows coolant should be changed.

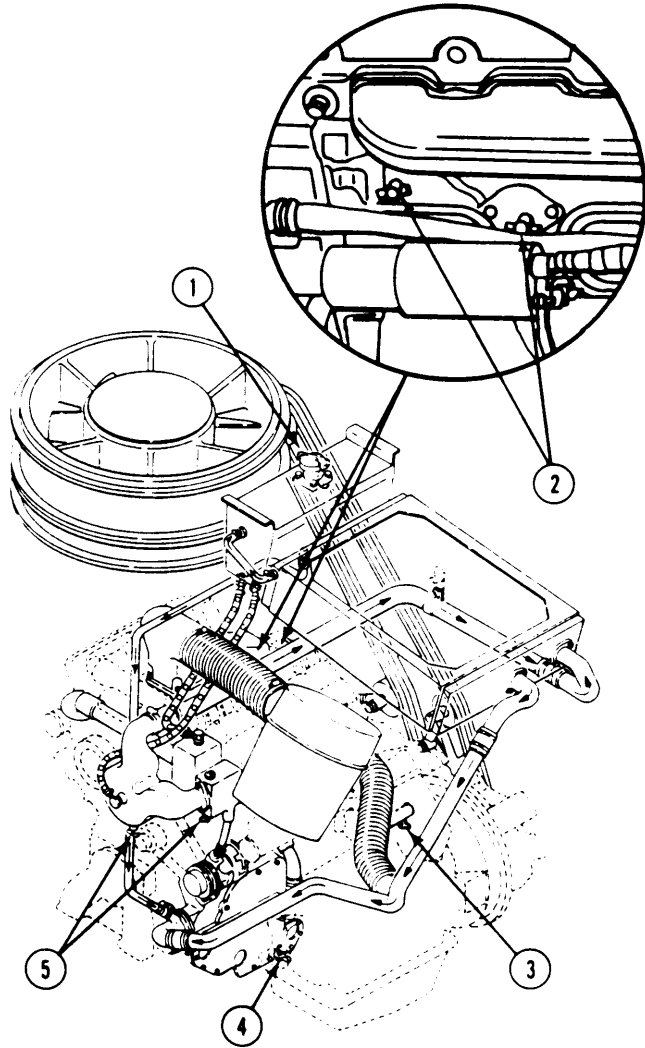

FOLLOW-THROUGH STEPS

1. Install hull bottom access cover (page 24-32).

END OF TASK

FILL COOLING SYSTEM

INITIAL SETUP

Tools:

General Mechanics Tool Kit (Item 30, App D)
Antifreeze and Battery Tester
(Item 74, App D)

Materials/Parts:

Antifreeze (Item 3, App C)
Container (14 gallon)

Personnel Required:

Unit Mechanic

References:

see your -10
See your -LO

Equipment Conditions:

Engine stopped/shutdown (see your -10)
Carrier blocked (see your -10)
Driver's power plant access panel removed
(page 24-25)
Power plant rear access panel removed
(page 24-27 or 24-29)

NOTE

When filling the radiator, add coolant slowly to allow trapped air to escape.

Use antifreeze coolant in system at all times. It will reduce corrosion in engine block and cooling system parts. Ethylene glycol coolant will provide low temperature protection. Mix coolant and clean water based on protection label on container.

1. Make sure all six drain cocks (1,2,3 and 4) are closed and all tubes, hoses and connections are tight.
2. Remove coolant filler cap (5).

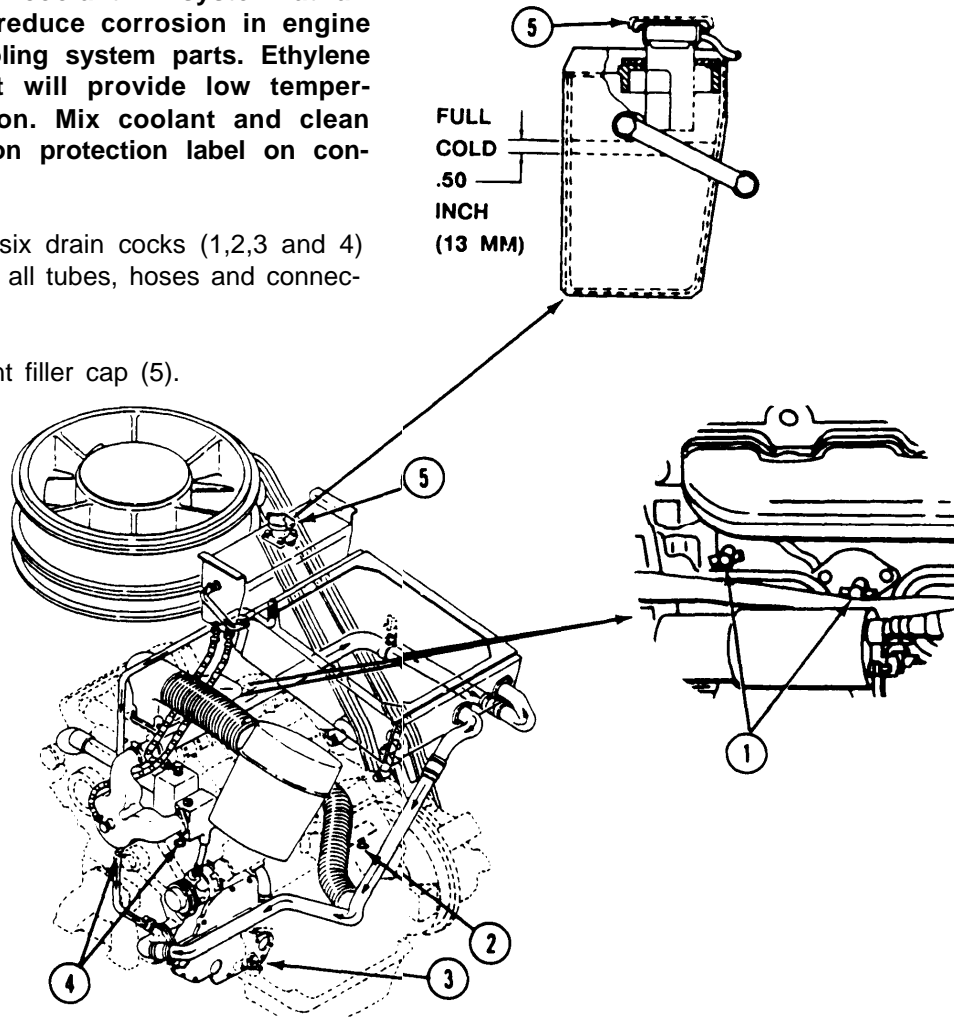

GO TO NEXT PAGE

3. Fill system slowly with 14 gallons (53 liters) of coolant. Bring coolant level to within 1/2 inch (13 mm) of bottom of filler neck.
4. Install coolant filler cap.

CAUTION

Do not operate engine if temperature exceeds 230°F (110°C). Serious engine damage will occur.

5. Start and run engine until it reaches 160°F to 200°F (71.1°C to 93.3°C) operating temperature. Check for leaks.

CAUTION

If engine coolant temperature gage reading is above 230°F (110°C), stop engine and allow it to cool.

Check the following for causes of engine overheating

Make sure air cleaner element is clean and installed correctly (see your -10).

Check fan belts (page 8-35) for correct adjustment.

Check radiator and intake grill air passages. Clean passages and remove debris that blocks free movement of air.

Check engine oil level. Check for correct grade of oil (see your -LO).

6. Stop/shutdown engine (see your -10) and allow it to cool.

WARNING



Hot radiator coolant can burn you. Use hand to remove cap ONLY if cool to touch. Turn cap slowly to release pressure. Replace cap by pressing down and

turning until tight.

7. Add coolant as necessary to within 1/2 inch (13 mm) of bottom of filler neck.
8. Using antifreeze and battery tester, check coolant for level of protection required for climate.

FOLLOW-THROUGH STEPS

1. Install power plant rear access panel (page 24-27 or 24-29).
2. Install driver's power plant access panel (page 24-25).
3. Close power plant front access door and raise trim vane (see your -10).

END OF TASK

CLEAN RADIATOR

INITIAL SETUP

Tools:

General Mechanics Tool Kit (Item 30, App D)
Radiator Cleaning Tool (Item 18, App D)

Material/Parts:

General purpose detergent (Item 17, App C)
Suitable container

Personnel Required:

Unit Mechanic

References:

See your -10

Equipment Conditions:

Engine stopped/shutdown (see your -10)
Carrier blocked (see your -10)
Driver's power plant access panel removed (see your -10)
Hull bottom access cover removed (24-32)
Trim vane lowered (see your -10)
Driver's power plant access door opened (see your -10)
Power plant rear access panel removed (see your -10)

CLEAN

1. Loosen two thumbscrews (1) and clamps (2). Remove radiator access panel (3) from power plant compartment bulkhead.

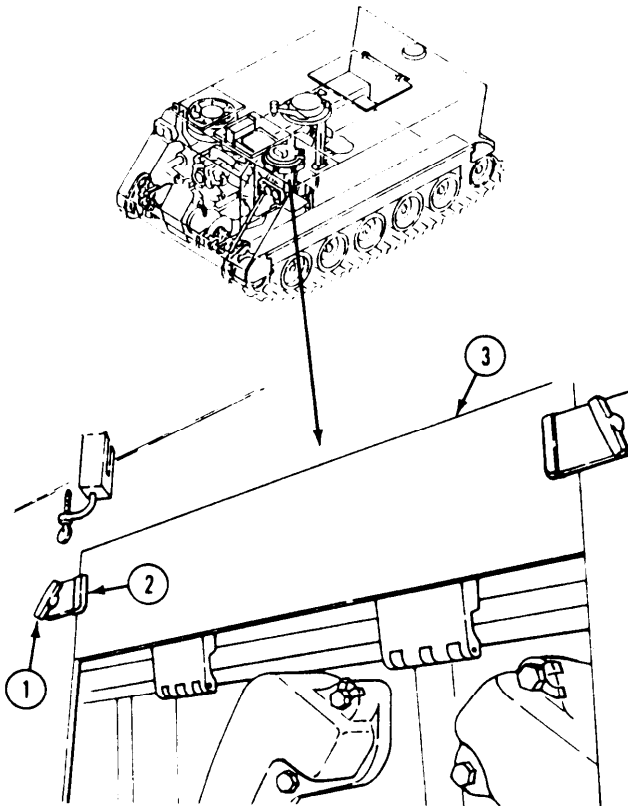

2. Release two fasteners (4) securing radiator access door (5) to radiator opening. Open door.
3. Cover exposed engine openings.
4. Mix one part detergent to five parts water in a clean container.
5. Submerge end of radiator cleaner siphon tube in detergent solution.

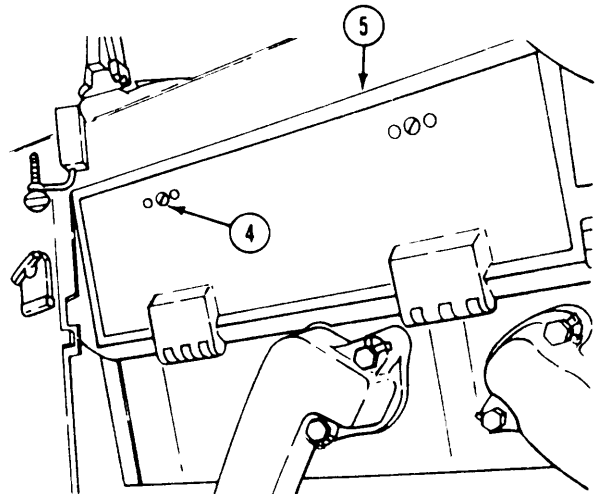

GO TO NEXT PAGE

WARNING

Air pressure in excess of 30 psi (207 kpa) can injure personnel. Do not direct pressurized air at yourself or others. Always wear goggles..

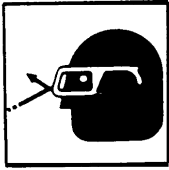

6. Attach radiator cleaning tool to available air supply.
7. Rinse radiator with clear water.
8. Clean sand, oil, and debris from radiator.
9. Remove siphon hose from detergent solution.

AIR SUPPLY LINE

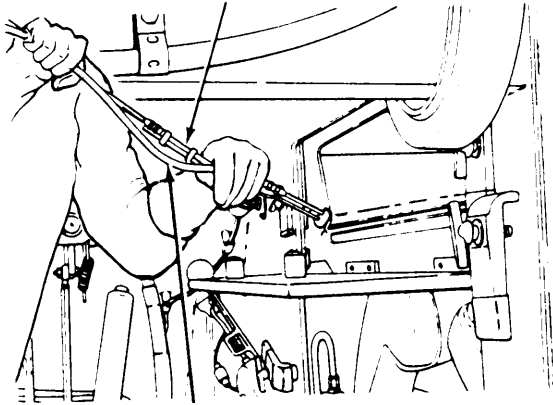

LIQUID SUPPLY LINE

10. Remove excess water with available air supply.
11. Uncover exposed engine openings.
12. Secure radiator access door (1) to radiator opening with two fasteners (2).

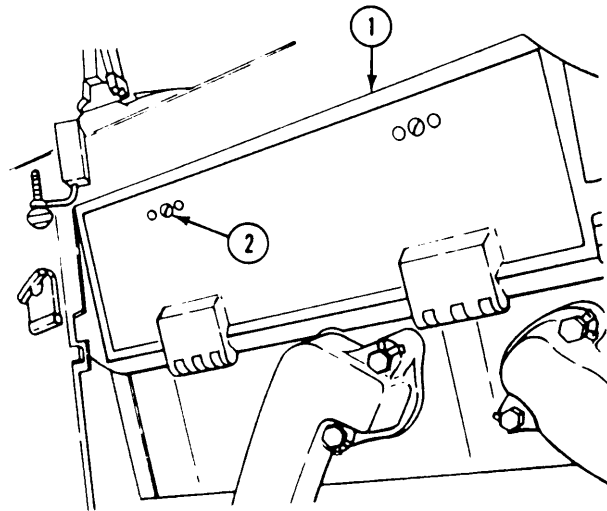

13. Secure radiator access panel (3) to power plant compartment bulkhead with two clamps (4) and thumbscrews (5).

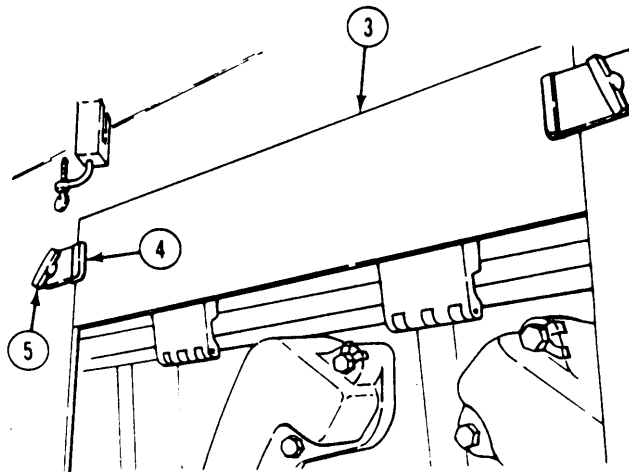

FOLLOW-THROUGH STEPS

1. Install hull bottom access cover (page 24-32).
2. Install driver's power plant access panel (see your -10).
3. Install power plant rear access panel (see your -10).
4. Close power plant front access door (see your -10).
5. Raise trim vane (see your -10).

END OF TASK

REPLACE ENGINE COOLANT PUMP IDLER PULLEY AND BELTS

DESCRIPTION

This task covers: Remove (page 8-9). Install (page 8-10).

INITIAL SETUP

Tools:

General Mechanics Tool Kit (Item 30, App D)
 Socket Wrench Set (Item 89, App D)
 Torque Wrench (Item 95, App D)

Personnel Required:

Unit Mechanic

References:

See your -10

Equipment Conditions:

Engine stopped/shutdown (see your -10)
 Carrier blocked (see your -10)
 Trim vane lowered and power plant front access door open (see your -10)

REMOVE

1. Remove two screws (1), washers (2), idler pulley (3), and idler adjusting bracket (4) from engine.
2. Remove two drive belts (5) from pulleys (6 and 7).

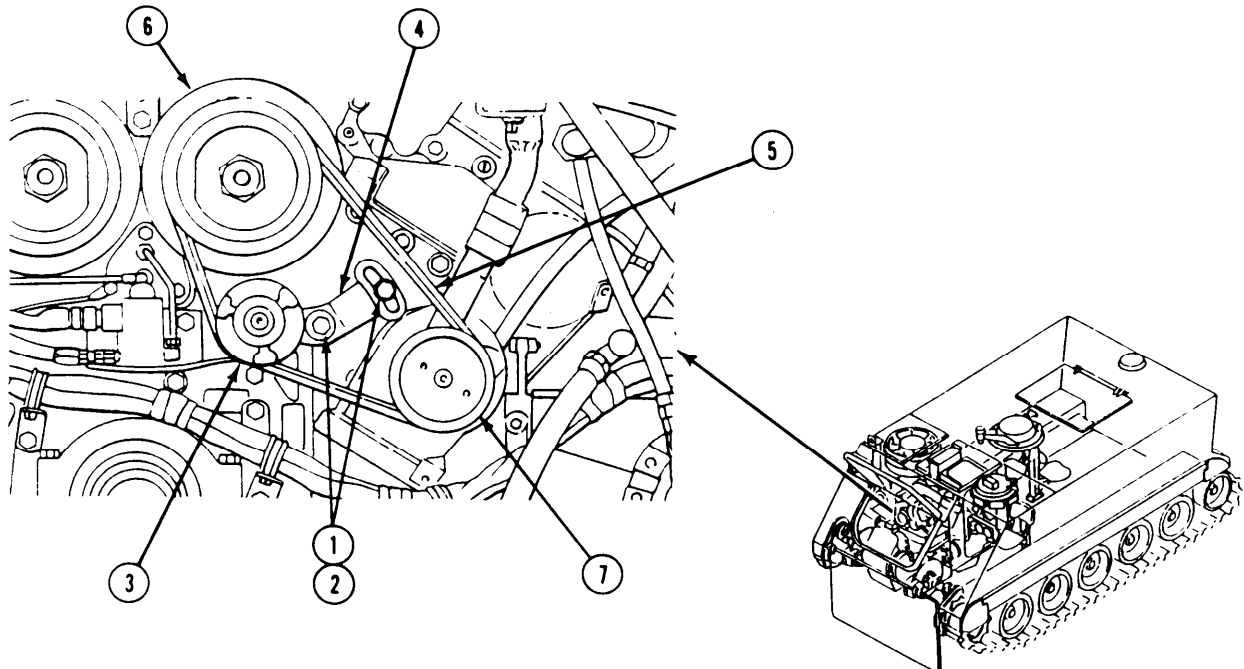

GO TO NEXT PAGE

INSTALL

NOTE

Drive belts must be replaced in matched sets

3. Position drive belts (1) on pulleys (2 and 3).
4. Install idler pulley (4) and idler bracket (5) on engine, with drive belts (1) positioned on idler pulley (4). Secure with two washers (6) and screws (7). Do not tighten screws.
5. To adjust drive belts (1), move idler bracket (5) to obtain a 3/8-inch (10 mm) deflection when drive belts (1) are depressed midway between pulleys (2 and 3).
6. After adjustment of drive belts (1), tighten two screws (7) to 360-420 lb-in (41-47 N•m) torque. Use torque wrench.

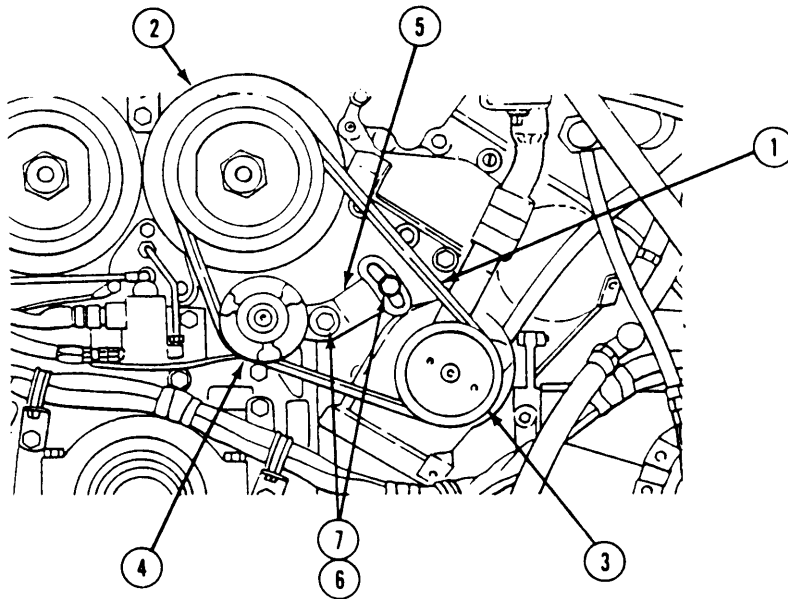

FOLLOW-THROUGH STEPS

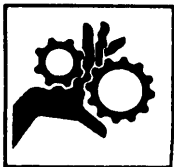

WARNING
Startup of equipment or moving parts can injure you. Stay clear of moving parts when power unit is running.

1. Start engine (see your -10). Check idler pulley for proper operation.
2. Stop/shutdown engine (see your -10).
3. Close power plant front access door and raise trim vane (see your -10).

END OF TASK

REPLACE ENGINE COOLANT PUMP

INITIAL SETUP

Tools:

General Mechanics Tool Kit (Item 30, App D)

Materials/Parts:

Sealing compound (Item 47, App C)

Gasket

Lockwasher (4)

Personnel Required:

Unit Mechanic

References:

See your -10

Equipment Conditions:

Power plant removed from carrier (page 5-11)

REMOVE

1. Remove coolant pump drive belts (page 8-9).
2. Loosen two clamps (1) and slide bypass hose (2) upward on thermostat tube (3).
3. Remove four cap screws (4), four washers (5), four lockwashers (6) one socket head screw (7), wiring harness bracket (8), coolant pump (9) and gasket (10) from oil cooler housing. Discard gasket and lockwashers.

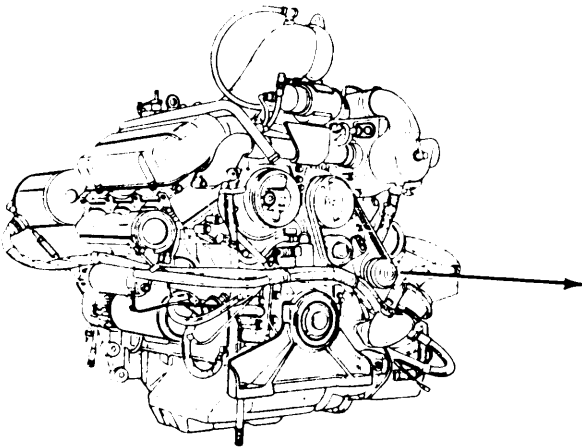

INSTALL

4. Apply sealing compound to new gasket (10). Secure gasket, coolant pump (9), and bracket (8) to oil cooler housing with one socket head screw (7), four washers (5), four new lockwashers (6) and cap screws (4).
5. Secure bypass hose (2) to thermostat tube (3) and coolant pump (9) with two clamps (1).
6. Install coolant pump drive belts (page 8-9).
7. Adjust coolant drive belts (page 8-9).

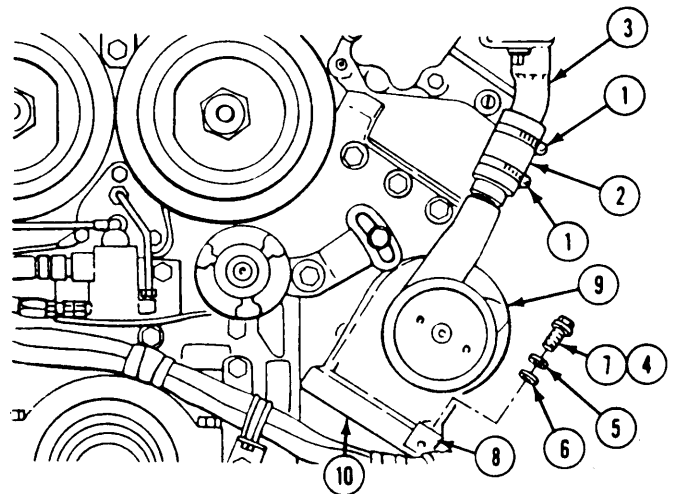

FOLLOW-THROUGH STEPS

1. Install power plant assembly in earner (page 5-11). Leave power plant access door open.
 2. Start engine (see your -10). Check for leaks around water pump and bypass hose.
 3. Stop/shutdown engine (see your -10).
 4. Close power plant front access door (see your -10).
-

END OF TASK

REPLACE DEAERATION ELBOW TO RADIATOR INLET ELBOW COOLANT TUBE

DESCRIPTION

This task covers: Remove (page 8-12). Install (page 8-13).

INITIAL SETUP

Tools:

General Mechanics Tool Kit (Item 30, App D)

Materials/Parts:

Self-locking nut
Self-locking nut

Personnel Required:

Unit Mechanic

References:

See your -10

Equipment Conditions:

Engine stopped/shutdown (see your -10)
Carrier blocked (see your -10)
Trim vane lowered and power plant front access door open (see your -10)
Driver's power plant access panel removed (page 24-25)
Power plant rear access panel removed (page 24-27 or 24-29)
Cooling system completely drained (page 8-3)

REMOVE

1. Remove two clamps (1) and hose (2) from deaeration elbow (3) and coolant tube (4).
2. Remove two clamps (5) and hose (6) from coolant tube (4) and radiator elbow (7).
3. Remove locknut (8), washer (9), screw (10), clamp (11) and coolant tube (4) from bracket (12). Discard locknut.
4. Remove coolant tube (4) through power plant rear access panel opening.
5. Remove clamp (11), two clamps (13) and insulation (14) from coolant tube (4).
6. Remove screw (15), washer (16), locknut (17) and bracket (12) from power plant compartment bulkhead. Discard locknut.

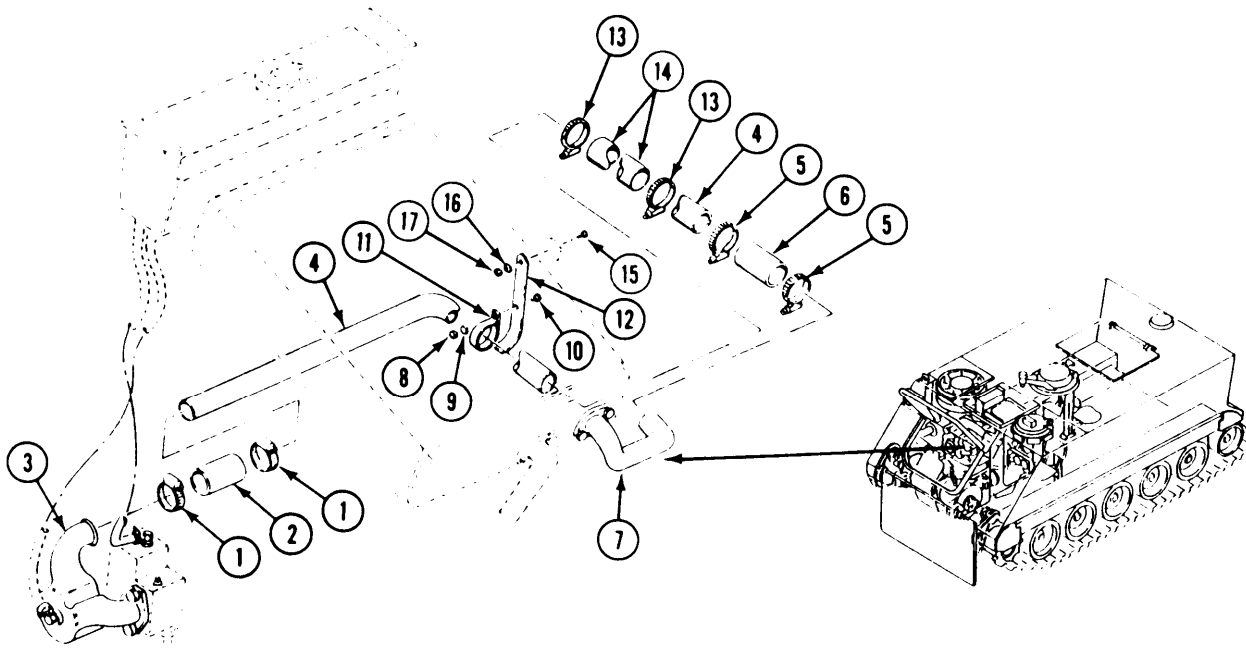

INSTALL

7. Secure insulation (1) to coolant tube (2) with two clamps (3).
8. Secure bracket (4) to bulkhead with screw (5), washer (6) and new locknut (7).
9. Place clamp (8) on coolant tube (2). Secure clamp to bracket (4) with screw (9), washer (10) and new locknut (11).
10. Secure hose (12) to radiator inlet elbow (13) and coolant tube (2) with two clamps (14).
11. Secure hose (15) to coolant tube (2) and deaeration elbow (16) with two clamps (17).

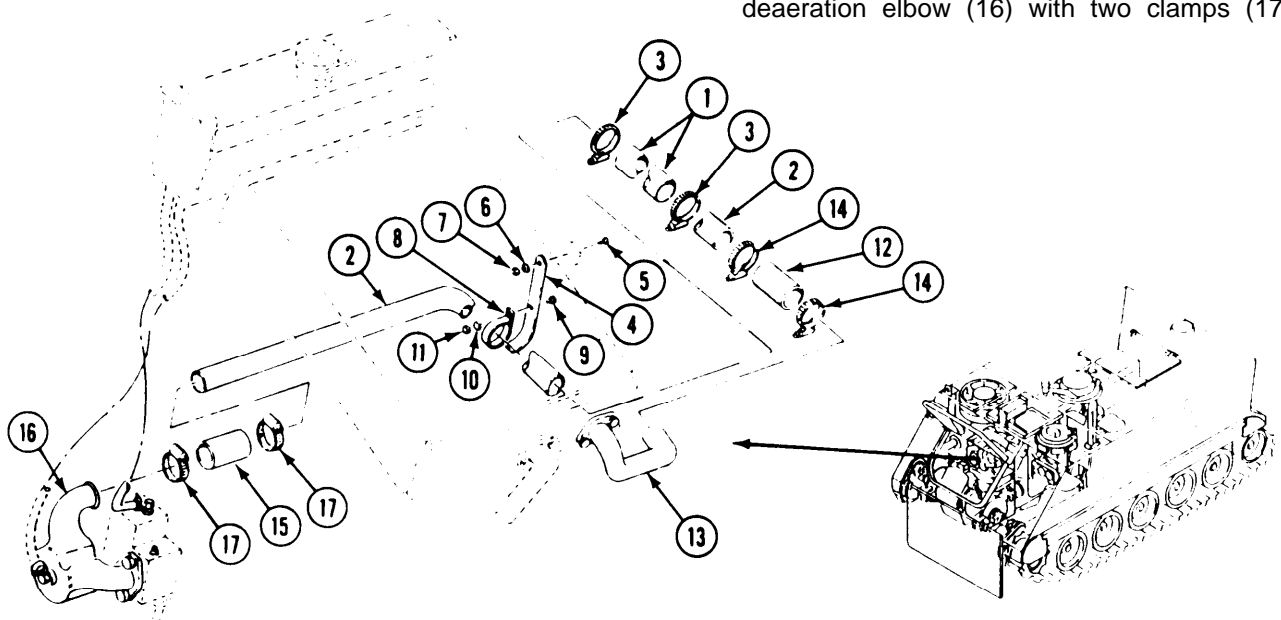

FOLLOW-THROUGH STEPS

1. Fill cooling system (page 8-5).
2. Start engine (see your -10). Check for leaks.
3. Stop/shutdown engine (see your -10).
4. Install driver's power plant access panel (page 24-25).
5. Install power plant rear access panel (page 24-27 or 24-29).
6. Close power plant front access door and raise trim vane (see your -10).

END OF TASK

REPLACE RADIATOR OUTLET ELBOW TO COOLANT PUMP ELBOW HOSE AND TUBE

INITIAL SETUP

Tools:

General Mechanics Tool Kit (Item 30, App D)

Personnel Required:

Unit Mechanic

References:

See your -10

Equipment Conditions:

Engine stopped/shutdown (see your -10)
 Carrier blocked (see your -10)
 Driver's power plant access panel removed (page 24-25)
 Trim vane lowered and power plant front access door open (see your -10)
 Cooling system completely drained (page 8-3)
 Air cleaner housing and element removed (page 7-7)

REMOVE

1. Remove two clamps (1) and hose (2) from coolant pump elbow (3) and tube (4).
2. Remove two clamps (5), hose (6) and tube (4) from radiator outlet elbow (7).
3. Remove tube (4) through power plant front access door opening.

INSTALL

4. Install tube (4) through power plant front access door opening.
5. Secure hose (2) to coolant pump elbow (3) and tube (4) with two clamps (1).
6. Secure hose (6) to radiator outlet elbow (7) and tube (4) with two clamps (5).

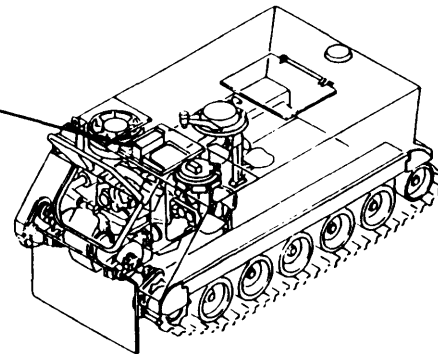
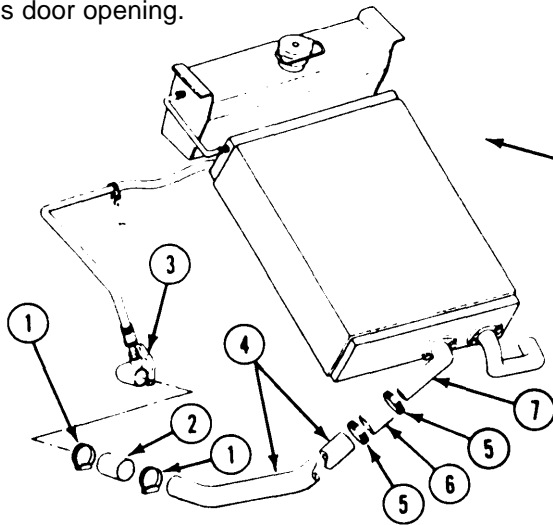

FOLLOW-THROUGH STEPS

1. Install air cleaner element and housing (page 7-7).
2. Fill cooling system (page 8-5).
3. Start engine (see your -10). Check for leaks.
4. Stop/shutdown engine (see your -10).
5. Install driver's power plant access panel (page 24-25).
6. Close power plant front access door and raise trim vane (see your -10).

END OF TASK

REPLACE THERMOSTAT, HOUSING, AND DEAERATION ELBOW

DESCRIPTION

This task covers: Remove (page 8-15). Install (page 8-16).

INITIAL SETUP

TOOLS

- General Mechanics Tool Kit (Item 30, App D)
- Socket Wrench Set (Item 89, App D)
- Torque Wrench (Item 95, App D)

Materials/Parts:

- Sealing compound Item 51, App C)
- Sealing compound (Item 48, App C)
- Deaeration elbow gasket
- Housing gasket
- Key washer (2)
- Lockwasher (6)
- Thermostat gasket

Personnel Required:

Unit Mechanic

References:

see your -10

Equipment Conditions:

- Engine stopped/shutdown (see your -10)
- Carrier blocked.
- Trim vane lowered and power plant front access door open (see your -10)
- Drain cooling system (page 8-3).
- Remove air cleaner housing and element (page 7-7).

REMOVE

1. Loosen two clamps (1). Disconnect hose (2) from elbow (3), and hose (4) from elbow (5).
2. Remove elbow (3) and drain cock (6) from deaeration elbow (7). Remove bushing (8) from thermostat housing (9).
3. Loosen two clamps (10). Disconnect hose (11) from deaeration elbow (7) and tube (12).
4. Remove two screws (13), key washers (14), deaeration elbow (7), and gasket (15) from thermostat housing cover (16). Discard key washers and gasket.
5. Loosen two clamps (17). Disconnect hose (18) from cover (16).
6. Remove four screws (19), lockwashers (20), washers (21), cover (16), and gasket (22) from housing (9). Discard lockwashers and gasket.
7. Remove thermostat (23), seal (24), and drain cock (25) from cover (16).

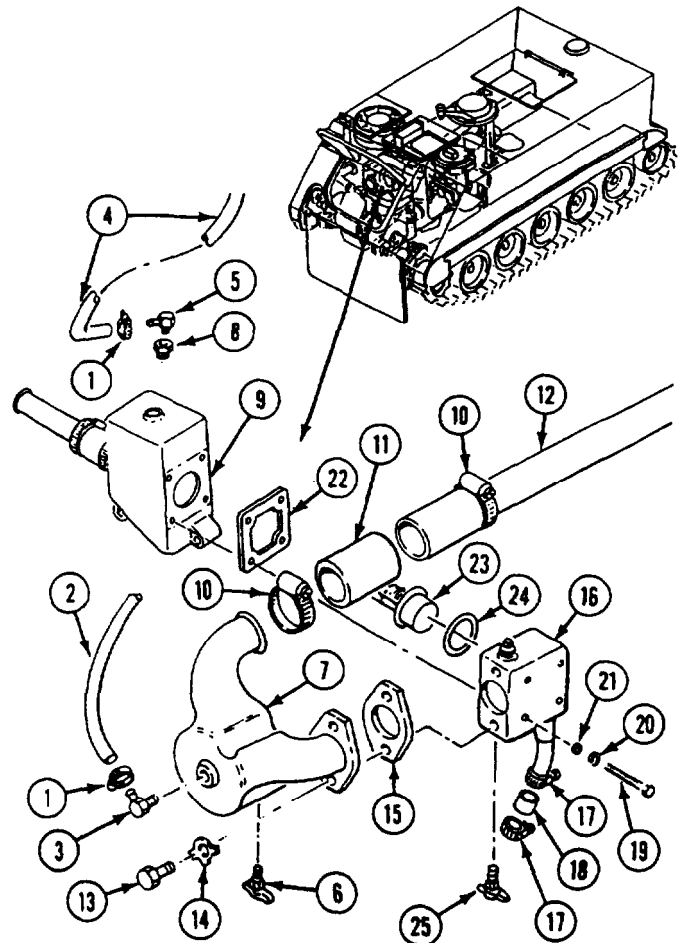

GO TO NEXT PAGE

8. Loosen two clamps (1). Slide hose (2) off the housing (3).
9. Remove two screws (4), lockwashers (5), and washers (6) securing housing (3) to the engine. Remove housing (3) and gasket (7). Discard lockwashers and gasket.
10. If hose (2) is damaged, slide off tube (8). Discard hose.

INSTALL

11. If hose (2) was discarded, slide new hose on tube (8). Slide two clamps (1) on hose. Do not tighten.
12. Apply sealing compound (Item 48) to both sides of new gasket (7). Place gasket on housing (3). Secure housing (3) on engine with two screws (4), new lockwashers (5), and two washers (6).
13. Slide hose (2) onto housing (3). Position two clamps (1) on each end of hose, and tighten.

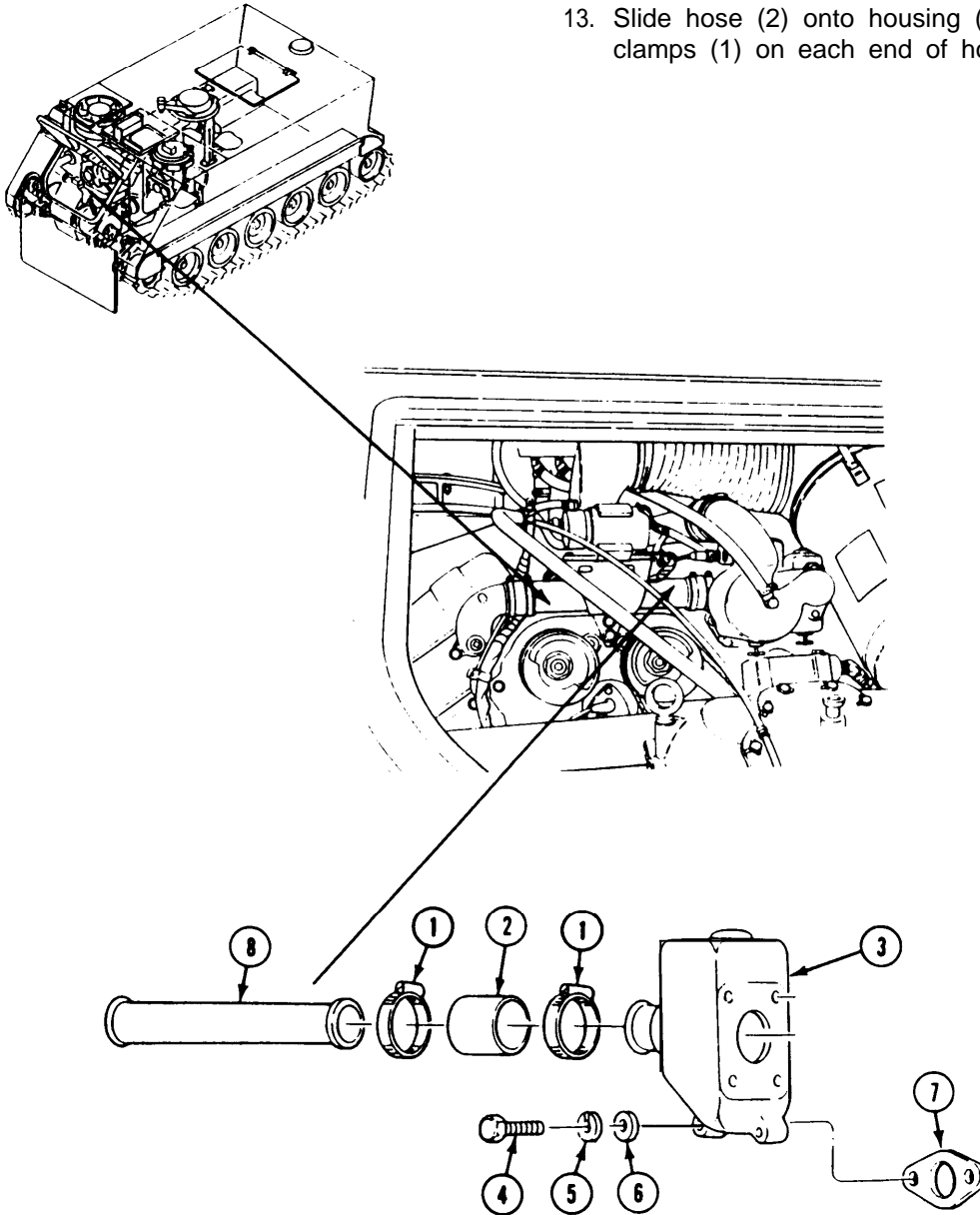

14. Apply a light coat of sealing compound (Item 51) to external threads of elbows (1 and 2), bushing (3), and drain cocks (4 and 5). Apply sealing compound (Item 48) to both sides of gaskets (6 and 7).
15. Install thermostat (8) and new gasket (7) in thermostat housing (9).
16. Install seal (10) in cover (11). Secure thermostat cover (11) to housing (9) with four new washers (12), lockwashers (13), and screws (14). Tighten screws to 180-240 lb-in (20-27 NŹm) torque. Use torque wrench and socket wrench set.
17. Connect hose (15) to cover (11) with two clamps (16). Tighten clamps.
18. Secure deaeration elbow (17) and new gasket (6) to cover (11) with two new key washers (18) and screws (19).
19. Connect hose (20) to deaeration elbow (17) and tube (21) with two clamps (22). Tighten chimps.
20. Install elbow (1) in deaeration elbow (17).
21. Secure hose (23) to elbow (1) with clamp (24).
22. Install bushing (3) in housing (9).
23. Install elbow (2) in bushing (3).

24. Secure hose (25) to elbow (2) with clamp (26).
25. Install drain cock (4) in deaeration elbow (17) and drain cock (5) in housing cover (11).

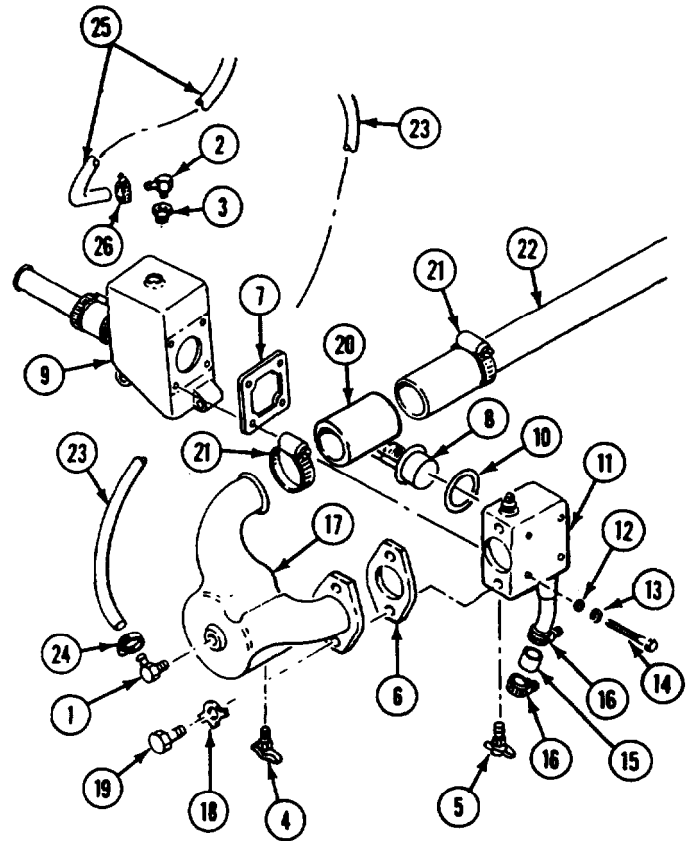

FOLLOW-THROUGH STEPS

1. Install air cleaner element and housing (page 7-7)
2. Fill cooling system (page 8-5).
3. Start engine (see your -10). Check for leaks.
4. Stop/shutdown engine (see your -10).
5. Close power plant front access door and raise trim vane (see your -10).

END OF TASK

REPLACE THERMOSTAT HOUSING TO ENGINE COOLANT TUBE

DESCRIPTION

This task covers: Remove (page 8-17). Install (page 8-18).

INITIAL SETUP

Tools:

General Mechanics Tool Kit (Item 30, App D)
Torque Wrench (Item 95, App D)

Materials/Parts:

Sealing compound (Item 46, App C)
Sealing compound (Item 48, App C)
Gasket
Lockwasher (2)

Personnel Required:

Unit Mechanic

References:

See your -10

Equipment Conditions

Engine stopped/shutdown (see your -10)
Carrier blocked (see your -10)
Trim vane lowered and power plant front access door open (see your -10)
Cooling system drained (page 8-3)

REMOVE

NOTE

Plug (1) should be removed only if you see leakage.

1. Remove two screws (2), lockwashers (3), and flat washers (4) securing elbow (5) to engine. Discard lockwashers.
2. Loosen two clamps (6) on hose (7). Move elbow (5), two clamps (8), hose (9), and coolant tube (10) to the left as a unit.
3. Loosen two clamps (8). Disassemble hose (9), coolant tube (10), and elbow (5).
4. Remove gasket (11) from elbow (5) or engine block. Discard gasket.

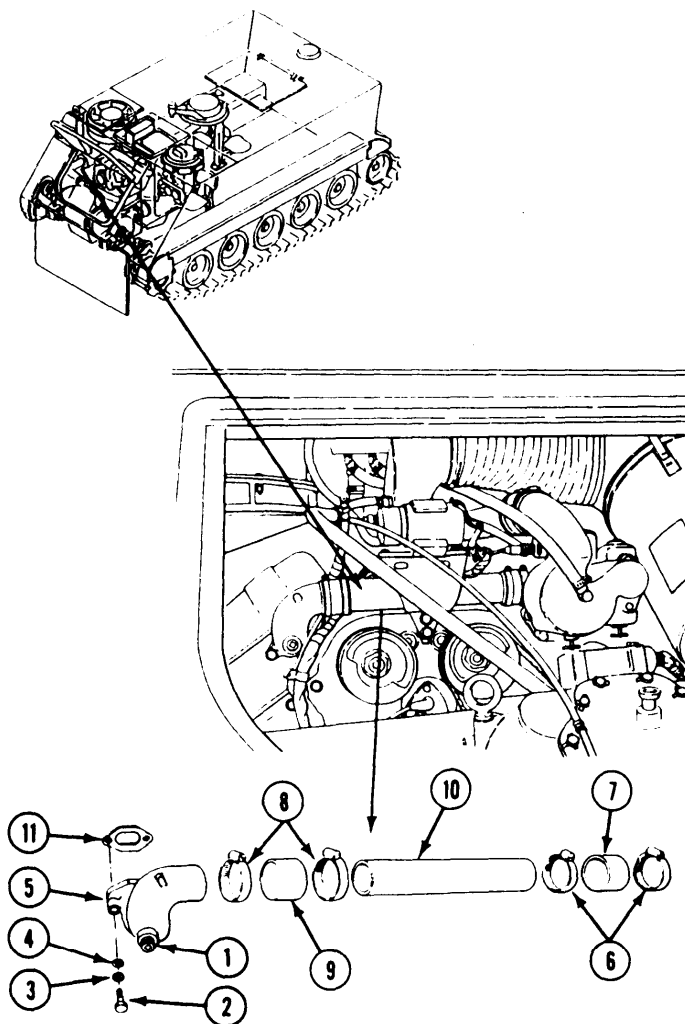

INSTALL**NOTE**

If plug (11) was removed, clean and apply a thin coat of sealing compound (Item 46) on threads before installing.

5. Connect coolant tube (1) to hose (2) with two clamps (3). Tighten two clamps (3).
6. Connect coolant tube (1) and elbow (4) with hose (5) and two clamps (6). Tighten two clamps (6).
7. Apply a thin coat of sealing compound (Item 48) to both sides of new gasket (7).
8. Install new gasket (7) between elbow (4) and engine. Secure with two flat washers (8), new lockwashers (9), and screws (10). Tighten screws to 360-384 lb-in (41-43 N•m) torque. Use torque wrench.

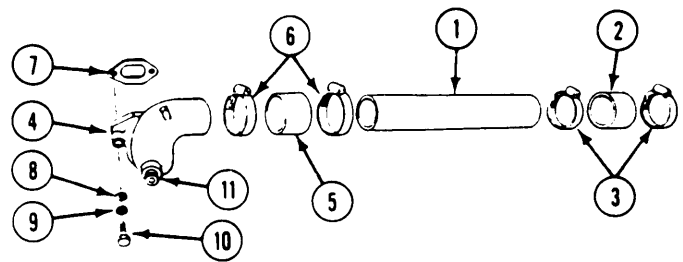
**FOLLOW-THROUGH STEPS**

1. Fill cooling system (page 8-5).
2. Start engine (see your -10). Check for leaks.
3. Stop/shutdown engine (see your -10).
4. Close power plant front access door and raise trim vane (see your -10).

END OF TASK

REPLACE RADIATOR AND PARTS

DESCRIPTION

This task covers: Remove (page 8-20). Install (page 8-21).

INITIAL SETUP

Tools:

General Mechanics Tool Kit (Item 30, App D)
 Endless Sling (Item 64, App D)
 Socket Wrench Set (Item 89, App D)
 Torque Wrench (Item 95, App D)

Materials/Parts

Sealing compound (Item 46, App C)
 Sealing compound (Item 52, App C)
 Gasket (2)
 Key washer (4)
 Mount (4)
 Seal (4)

Personnel Required:

Unit Mechanic

Personnel Required (cont):

Helper (H)

References:

See your -10

Equipment Conditions:

Engine stopped/shutdown (see your -10)
 Carrier blocked (see your -10)
 Driver's power plant access panel removed
 (page 24-25)
 Power plant rear upper access panel removed
 (page 24-27 or 24-29)
 Power plant grill raised (page 5-2)
 Balance hose removed (page 8-24)

REMOVE



WARNING

Radiator is heavy and can cause back injury if handled improperly. Be sure to use a hoist and helper to remove radiator.

1. Attach sling to lifting device of at least 150 lb (68 kg) capacity to radiator. Remove 10 nuts (1), 20 washers (2), and 10 screws (3) that secure radiator supports (4) to power plant grill (5). Lift radiator supports and radiator (6) from power plant grill. Lower radiator to a work table or flat wooden plate and detach lifting device. Have helper assist.

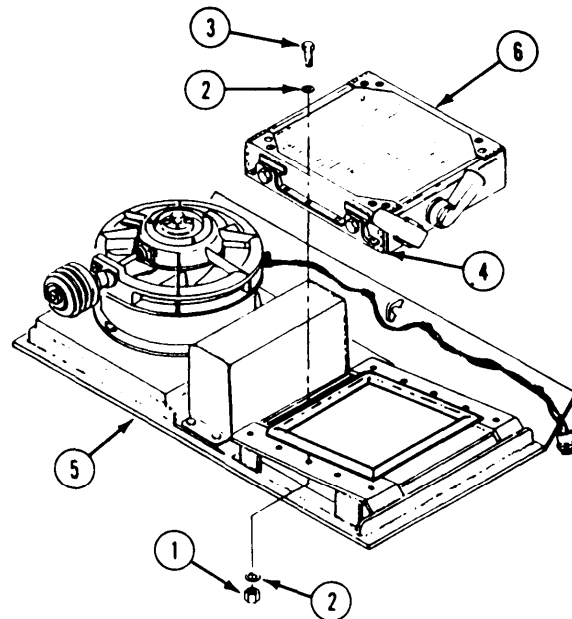

2. Remove two end seals (1) from power plant grill (2). Discard seals.
3. Remove two side seals (3) from power plant grill (2). Discard seals.

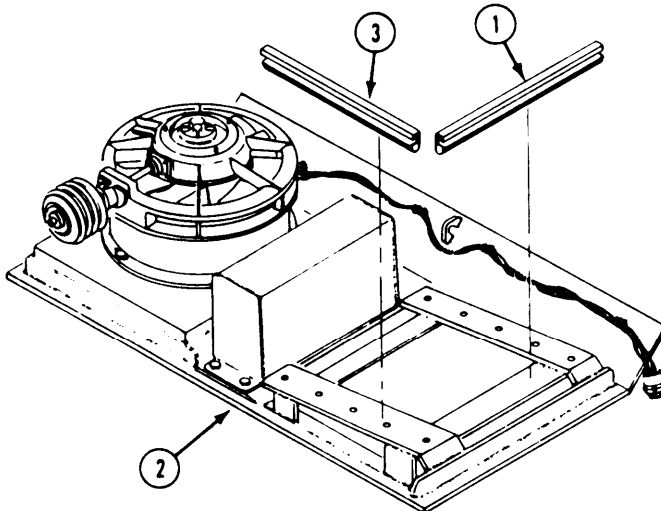

4. Remove balance hose adapter (4) from radiator (5).
5. Remove two screws (6), key washers (7), radiator outlet elbow (8), and gasket (9) from radiator (5). Discard gasket and washers.
6. Remove two screws (10), key washers (11), radiator inlet elbow (12), and gasket (13) from radiator (5). Discard gasket and washers.

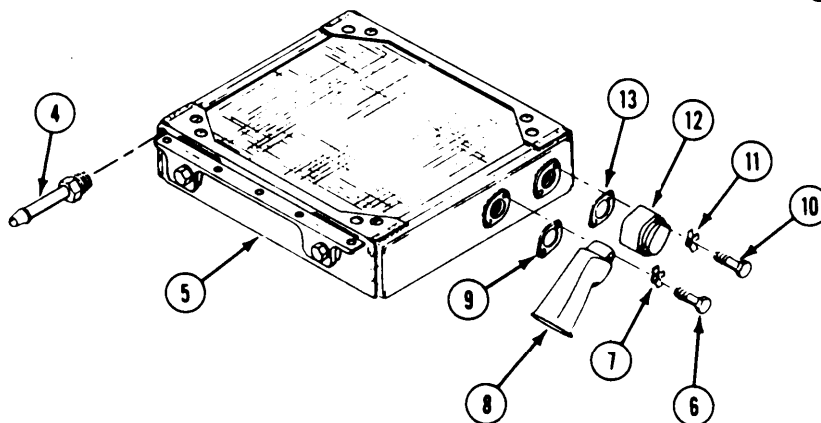

7. Remove four screws (14), washers (15), radiator supports (16), and mounts (17) from radiator (5). Discard mounts.

INSTALL

CAUTION

If installing a new radiator, make sure shipping plugs are removed.

8. Lubricate four new mounts (17) with water. Install mounts on two radiator supports (16).
9. Install two radiator supports (16) on radiator (5). Secure with four screws (14) and washers (15). Tighten screws to 360-420 in-lb (41-48 N•m) torque. Use torque wrench and socket wrench set.

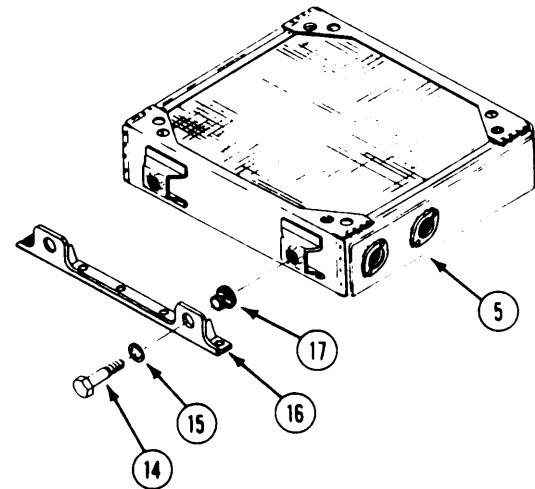

GO TO NEXT PAGE

10. Apply a thin coat of sealing compound to both sides of new gaskets (1 and 2) and external threads of adapter (3).
11. Install radiator inlet elbow (4) and new gasket (1) on radiator (5). Secure with two screws (6) and new key washers (7).
12. Install radiator outlet elbow (8) and new gasket (2) on radiator (5). Secure with two screws (9) and new key washers (10).
13. Install balance hose adapter (3) on radiator (5).
17. Attach lifting device of at least 150 lb (68 kg) capacity to radiator support eyes (14), Lift and place radiator on four seals (11 and 12).
18. Align mounting holes of two radiator supports (15) to power plant grill (13). Secure radiator on power plant grill with 10 screws (16), 20 washers (17), and 10 nuts (18).

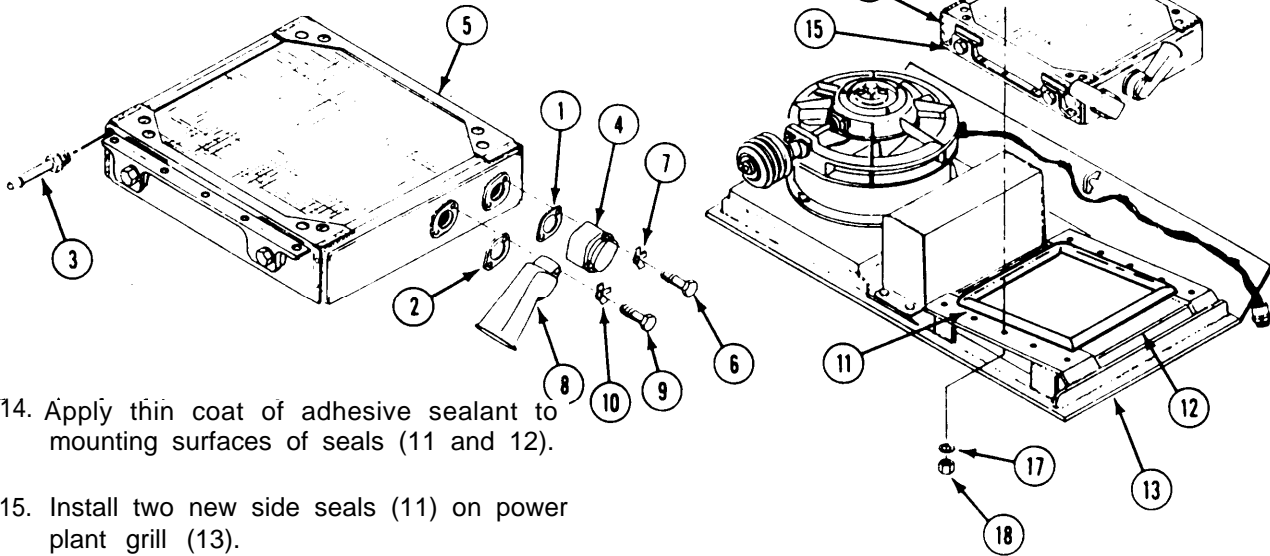

14. Apply thin coat of adhesive sealant to mounting surfaces of seals (11 and 12).
15. Install two new side seals (11) on power plant grill (13).
16. Install two new end seals (12) on power plant grill (13).

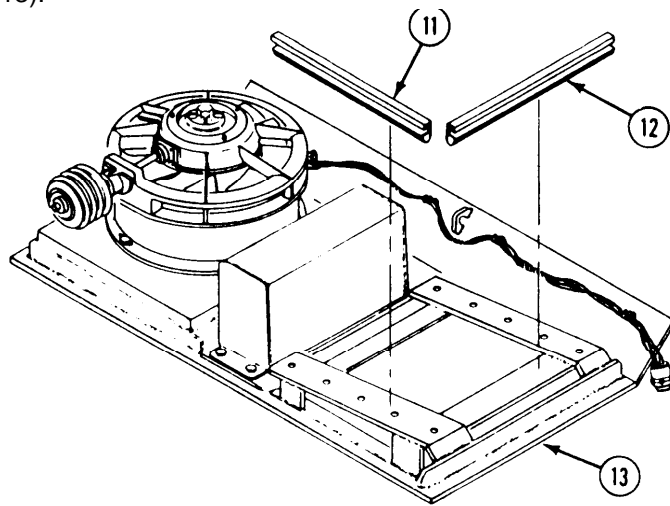

FOLLOW-THROUGH STEPS

1. Install balance hose (page 8-24)
2. Lower power plant grill (page 5-2).
3. Install power plant rear access panel (page 24-27 or 24-29).
4. Install driver's power plant access panel (page 24-25).

END OF TASK

REPLACE BALANCE HOSE

INITIAL SETUP

Tools:

General Mechanics Tool Kit (Item 30, App D)

Personnel Required:

Unit Mechanic

References:

See your -10

Equipment Conditions:

Engine stopped/shutdown (see your -10)
Carrier blocked (see your -10)
Power plant grill raised (page 5-2)

REMOVE

1. Loosen two clamps (1) on balance hose (2).
Remove hose and clamps.

INSTALL

2. Slide two clamps (1) on new balance hose (2).
3. Install balance hose (2) on auxiliary tank (3)
and radiator (4). Tighten two clamps (1).

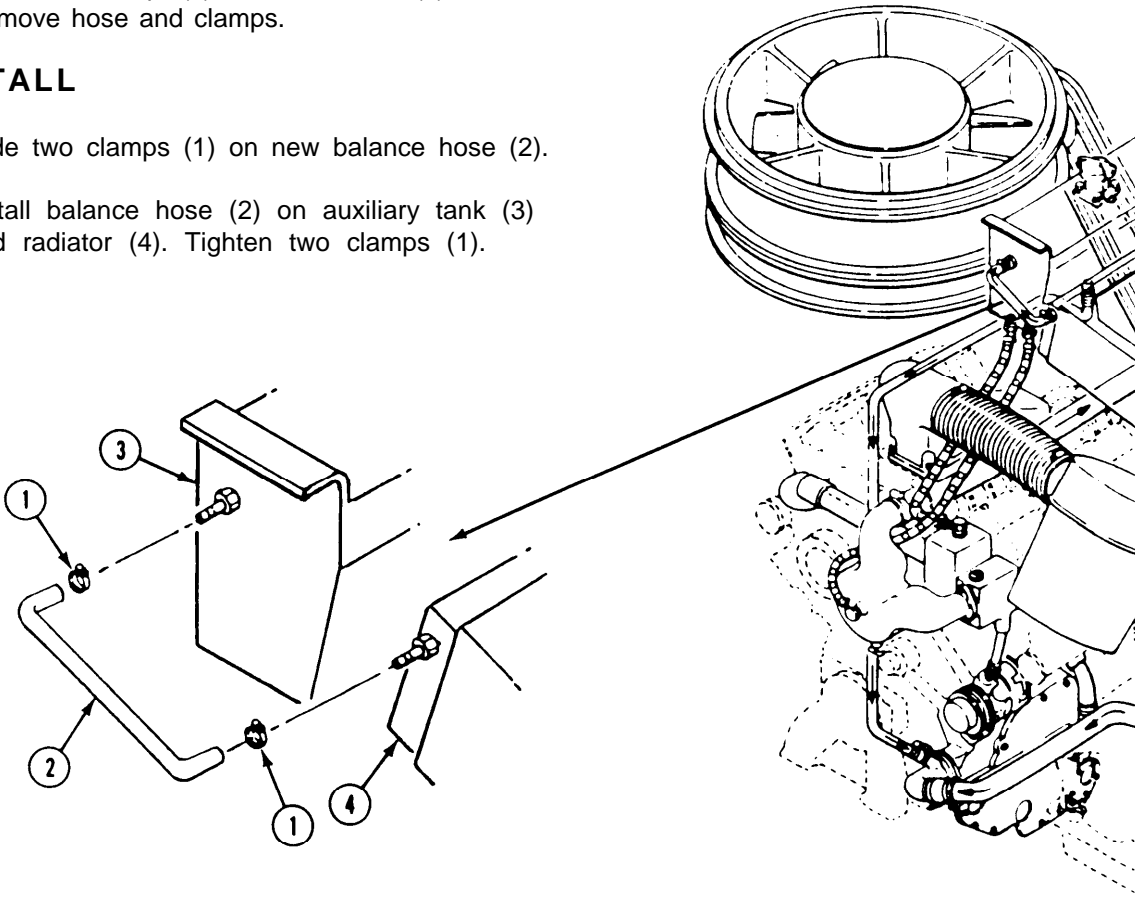

FOLLOW-THROUGH STEPS

1. Lower power plant grill (page 5-2).

END OF TASK

REPAIR RADIATOR ACCESS DOOR SEALS AND FASTENERS

DESCRIPTION

This task covers: Remove (page 8-25). Repair (page 8-26), Install (page 8-26).

INITIAL SETUP

Tools:

General Mechanics Tool Kit (Item 30, App D)
Rivet tool (Item 59, App D)

Materials/Parts:

Dry cleaning solvent (Item 13, App C)
Sealing compound (Item 52, App C)
Rivet (4)
Seal

Personnel Required:

Unit Mechanic

References:

see your -10

Equipment Conditions

Engine stopped/shutdown (see your -10)
Driver's power plant access panel removed
(page 24-25)

REMOVE

1. Loosen two thumbscrews (1) and clamps (2). Remove radiator access panel (3) from power plant compartment bulkhead.
2. Release two fasteners (4) securing radiator access door (5) to radiator opening, and open door.
3. Remove four rivets (6) and two fasteners (4) from radiator access door (5). Discard rivets.



WARNING

Dry cleaning solvent P-D 680 is toxic and flammable. Always use in an open area with good air flow, away from sparks, heat, or flames. Wear goggles and gloves. Do not breathe vapors. Avoid contact with skin, eyes, and clothes. If you get dizzy while using solvent, breathe fresh air and get medical help. If solvent gets on hands, wash them. If solvent gets in eyes, flush eyes with fresh water and get medical help immediately. Keep fire extinguisher nearby.

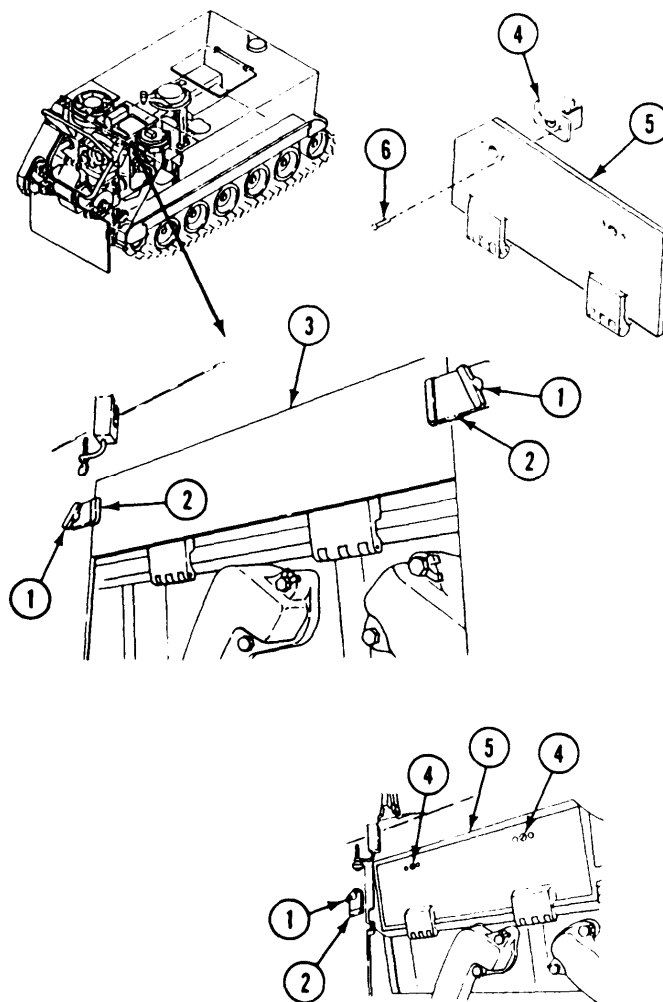

GO TO NEXT PAGE

REPAIR

4. Use dry cleaning solvent to remove five-piece seal (1) from radiator access door (2).
5. Apply a thin coat of adhesive sealant to bottom surface of new five-piece seal (1). Apply same sealant to seal area of radiator access door (2).

INSTALL

6. Install new five-piece seal (1) on radiator access door (2). Allow 20 minutes to dry.
7. Secure two fasteners (3) to radiator access door (2) with four new rivets (4). Use rivet tool.
8. Close radiator access door (2). Secure door to radiator opening with two fasteners (3).
9. Secure radiator access panel (5) to power plant compartment bulkhead with two clamps (6) and thumbscrews (7).

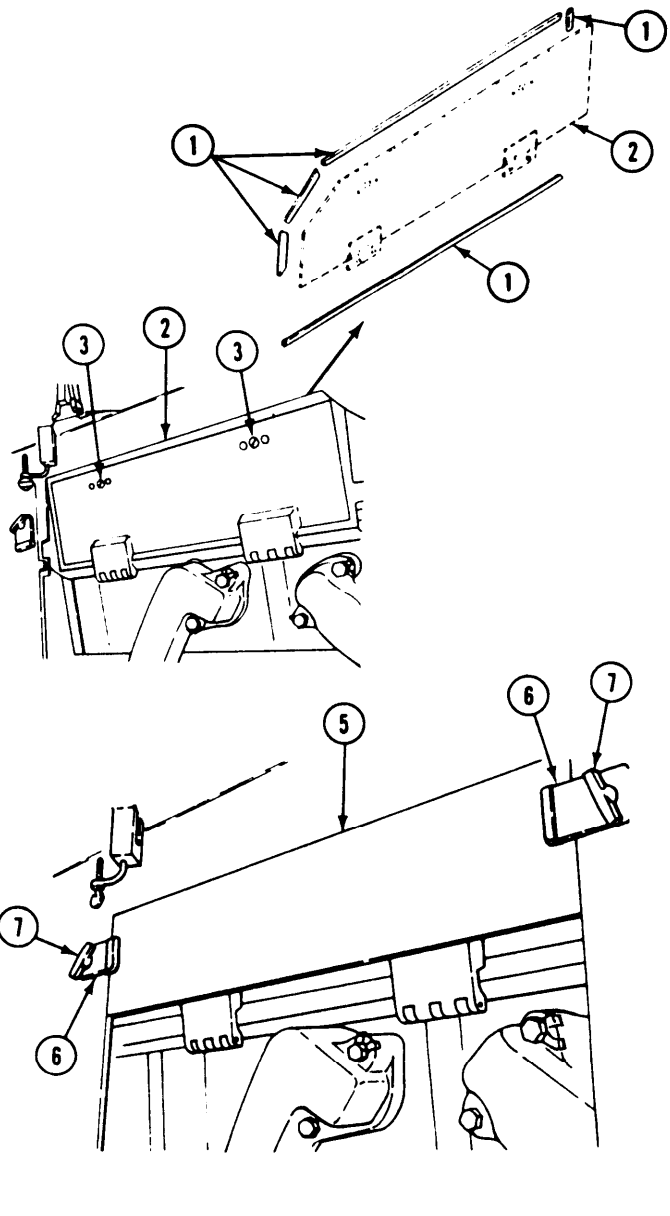

FOLLOW-THROUGH STEPS

Install driver's power plant access panel (page 24-25).

END OF TASK

REPAIR RADIATOR ACCESS DOOR

INITIAL SETUP

Tools:

General Mechanics Tool Kit (Item 30, App D)

Materials/Parts:

Locknut (4)

Personnel Required:

Unit Mechanic

References:

See your -10

Equipment Conditions:

Engine stopped/shutdown (see your -10)

Carrier blocked (see your -10)

Driver's power plant access panel removed
(page 24-25)

REMOVE

1. Loosen two thumbscrews (1) and clamps (2). Remove radiator access panel (3) from power plant compartment bulkhead.
2. Release two fasteners (4) on access door (5) and lower access door.
3. Remove four screws (6), flat washers (7), and locknuts (8). Remove access door (5). Discard four locknuts.

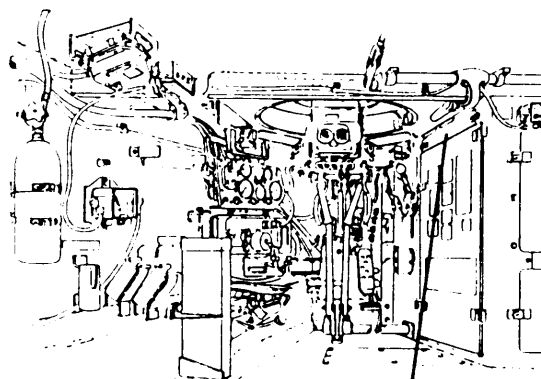

INSTALL

4. Position access door (5) and install four screws (6), flatwashers (7), and new locknuts (8).
5. Close radiator access door (5) and secure two fasteners (4).
6. Install radiator access panel (3) on power plant compartment bulkhead. Secure with two clamps (2) and bolts (1).

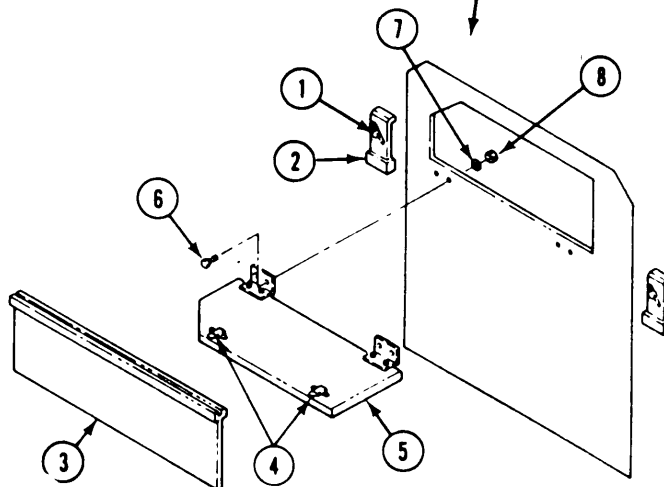

FOLLOW-THROUGH STEPS

1. Install driver's power plant access panel (page 24-25).
-

END OF TASK

REPLACE AUXILIARY TANK AND PARTS

DESCRIPTION

This task covers: Remove (page 8-28). Install (page 8-29).

INITIAL SETUP

Tools:

General Mechanics Tool Kit (Item 30, App D)
 Socket Wrench Set (Item 89, App D)
 Torque Wrench (Item 95, App D)

Materials/Parts:

Sealing compound (Item 46, App C)
 Sealing compound (Item 48, App C)
 Filler neck gasket
 Lockwasher (4)

Personnel Required:

Unit Mechanic

References:

see your -10

Equipment Conditions:

Engine stopped/shutdown (see your -10)
 Carrier blocked (see your -10)
 Power plant grill raised (page 5-2)

REMOVE

1. Loosen three clamps (1), Disconnect three hoses (2) from auxiliary tank (3).
2. Remove adapter (4) and two elbows (5) from auxiliary tank (3).
3. Remove four screws (6), washers (7), and auxiliary tank (3) from power plant grill.

4. Remove two hooks (8) and chain (9) from bracket (10) and filler cap (11).
5. Remove filler cap (11) from filler neck (12).
6. Remove four screws (13), flat washers (14), lockwashers (15), filler neck (12), bracket (10), and gasket (16) from auxiliary tank (3). Discard gasket and lockwashers.

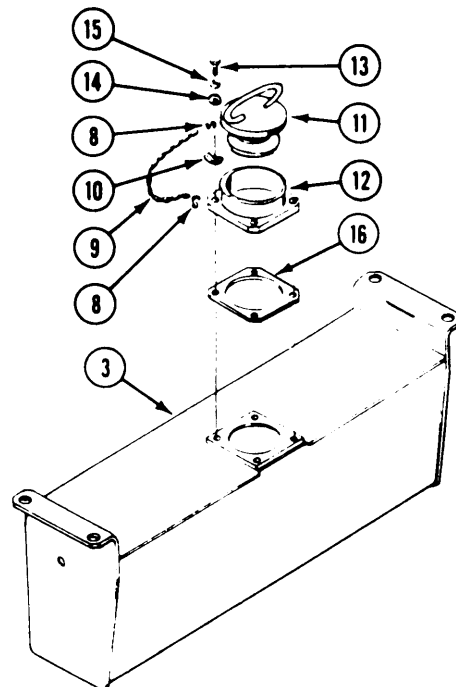
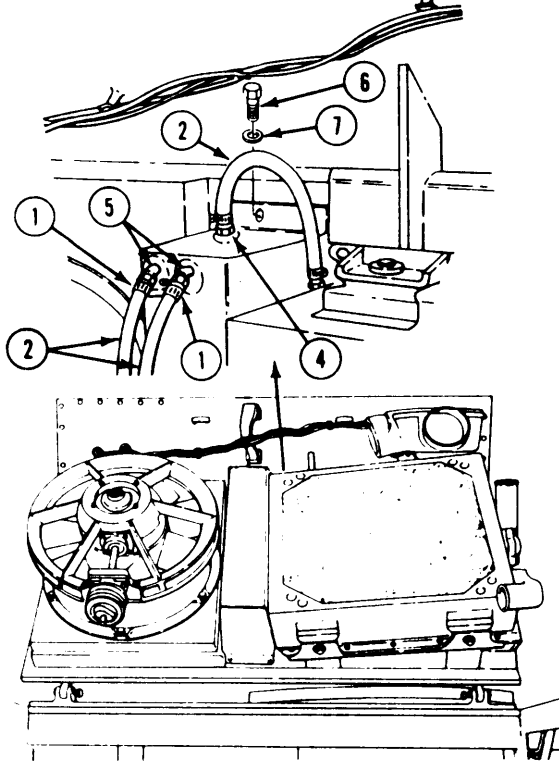

INSTALL

7. Apply thin coat of sealing compound (Item 48) to both sides of new gasket (1).
8. Install new gasket (1), filler neck (2), and bracket (3) on auxiliary tank (4). Secure with four screws (5), flat washers (6), and new lockwashers (7).
9. Secure chain (8) to bracket (3) and filler cap (9) with two hooks (10).
10. Install filler cap (9) in filler neck (2).
11. Apply thin coat of sealing compound (Item 46) to external threads of adapter (11) and two elbows (12).
12. Install adapter (11) and two elbows (12) in auxiliary tank (4).
13. Secure auxiliary tank (4) to power plant grill with four screws (13) and washers (14). Tighten screws to 264-288 il-in (30-33 N-m) torque. Use torque wrench and socket wrench set.
14. Secure three hoses (15) to auxiliary tank (4) with three clamps (16).

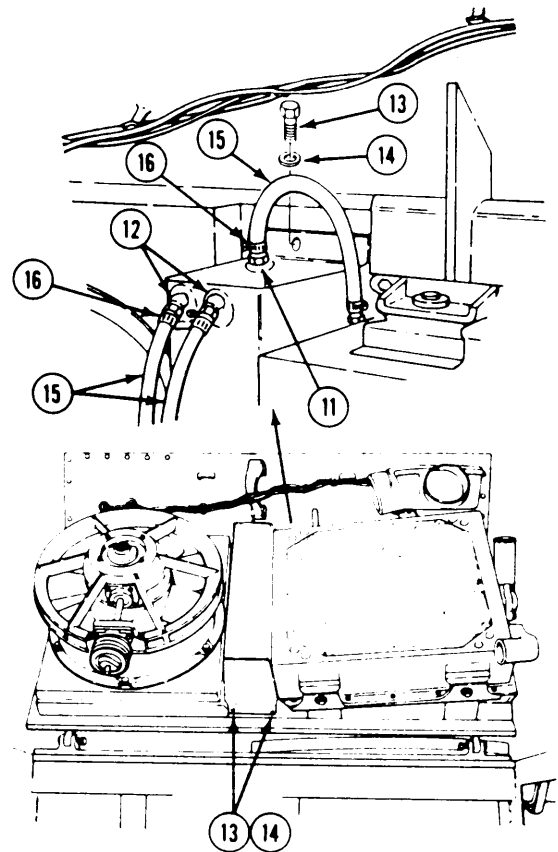
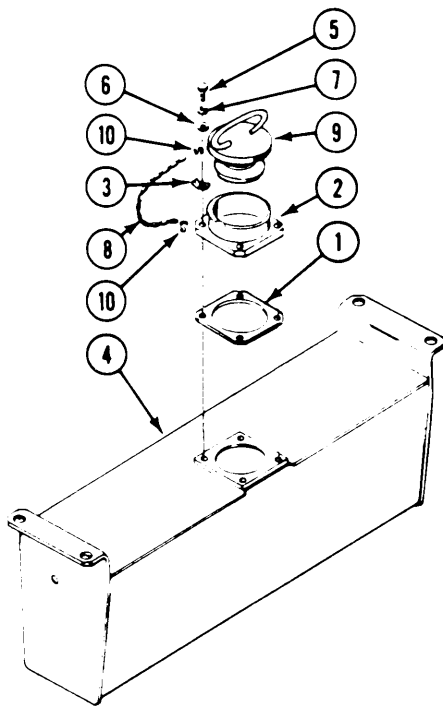

FOLLOW-THROUGH STEPS

1. Lower power plant grill (page 5-2).
2. Start engine (see your -10). Check for leaks.
3. Stop/shutdown engine (see your -10).

END OF TASK

REPLACE AUXILIARY TANK TO COOLANT PUMP TUBE

INITIAL SETUP

Tools:

General Mechanic's Tool Kit (Item 30, App D)

References:

See your -10

Materials/Parts:

Sealing compound (Item 46, App C)

Equipment Conditions:

Engine stopped/shutdown (see your -10)
 Carrier blocked (see your -10)
 Trim vane lowered and power plant front access door open (see your -10)
 Drain cooling system (page 8-3)

Personnel Required

Unit Mechanic

REMOVE

1. Remove screw (1), washer (2), and clamp (3) from bracket (4).
2. Loosen two clamps (5). Disconnect hose (6) from adapter (7) and tube (8).
3. Loosen two clamps (9). Disconnect hose (10) from tube (8) and auxiliary tank (11).
4. Remove adapter (7) from oil cooler elbow (12).
5. Remove tube (8) from carrier, and clamp (3) from tube.

10. Secure hose (6) to tube (8) and adapter (7) with two clamps (5).
11. Secure clamp (3) to bracket (4) with screw (1) and washer (2).

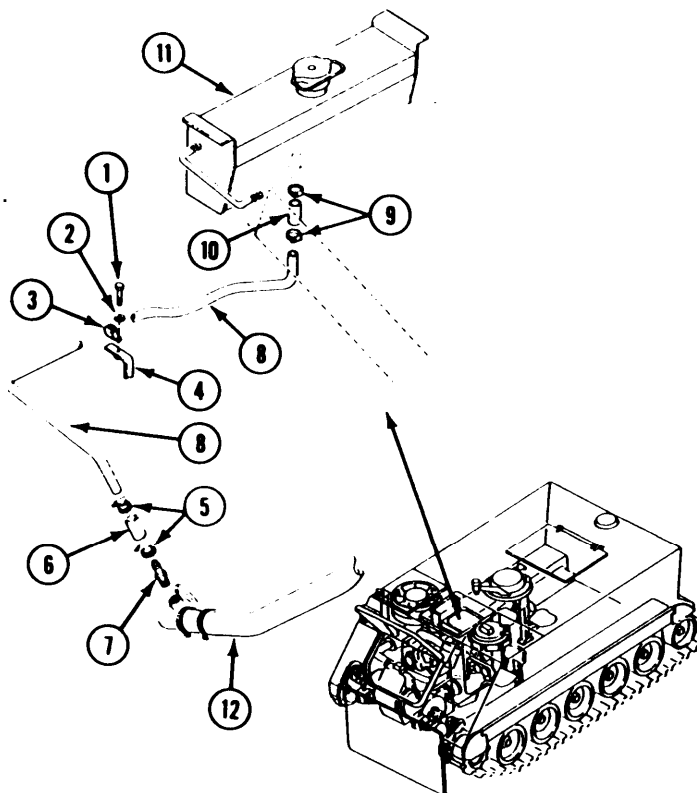

INSTALL

6. Apply a light even coat of sealing compound to external threads of adapter (7).
7. Install adapter (7) in oil cooler elbow (12).
8. Install clamp (3) on tube (8).
9. Secure hose (10) to auxiliary tank (11) and to tube (8) with two clamps (9).

FOLLOW-THROUGH STEPS

1. Fill cooling system (page 8-5).
2. Start engine (see your -10). Check for leaks.
3. Stop/shutdown engine (see your -10).
4. Close power plant front access door and raise trim vane (see your -10).

END OF TASK

REPLACE AUXILIARY TANK TO RADIATOR TUBE

INITIAL SETUP

Tools:

General Mechanics Tool Kit (Item 30, App D)

References:

See your -10

Materials/Parts:

Sealing compound (Item 46, App C)

Equipment Conditions:

Engine stopped/shutdown (see your -10)

Carrier blocked (see your -10)

Power plant grill raised (page 5-2)

Personnel Required:

Unit Mechanic

REMOVE

1. Remove two clamps (1) and hose (2) from two adapters (3).
2. Remove two adapters (3) from auxiliary tank (4) and radiator (5).

INSTALL

3. Apply a thin, even coat of sealing compound to external threads of two adapters (3).
4. Install two adapters (3) in auxiliary tank (4) and radiator (5).
5. Secure hose (2) to two adapters (3) with two clamps (1).

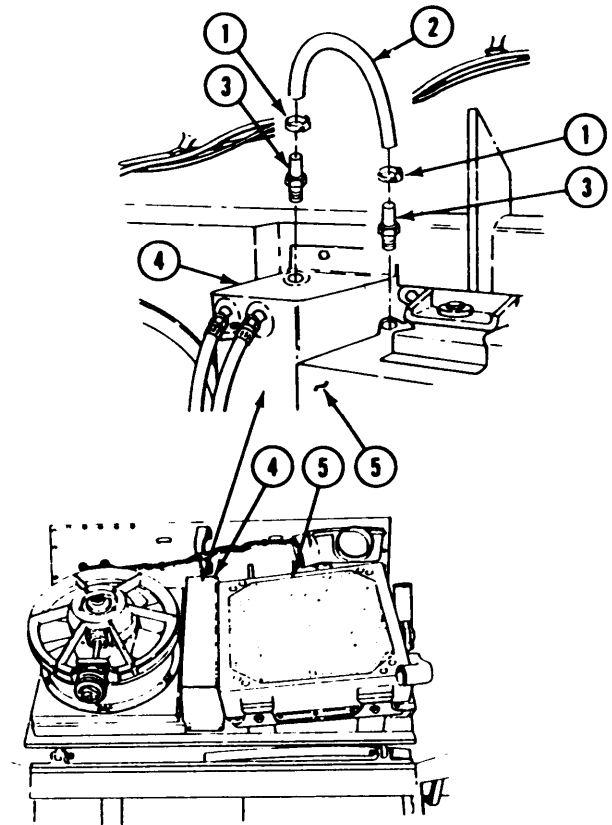

FOLLOW-THROUGH STEPS

1. Lower power plant grill (page 5-2).

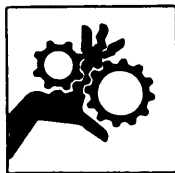

WARNING
 Wearing loose clothing around moving parts can allow personnel to get caught and cause injury or death. Tuck in loose clothing .

2. Start engine (see your -10). Check for leaks.
3. Stop/shutdown engine (see your -10).
4. Close power plant door (see your -10).

END OF TASK

REPLACE AUXILIARY TANK DEAERATION HOSES

INITIAL SETUP

Tools:

General Mechanics Tool Kit (Item 30, App D)

Personnel Required:

Unit Mechanic

References:

See your -10

Equipment Conditions:

Engine stopped/shutdown (see your -10)
 Carrier blocked (see your -10)
 Trim vane lowered and power plant front access door open (see your -10)
 Coolant drained (page 8-3)

REMOVE

1. Remove two clamps (1) and two deaeration hoses (2) from two elbows (3).
2. Remove clamp (4) from elbow (5), and clamp (6) from elbow (7).
3. Remove two hoses from carrier.

INSTALL

3. Secure two hoses (2) to elbows (3) with clamps (1).
4. Secure two hoses (2) to elbows (5 and 7) with clamps (4 and 6).

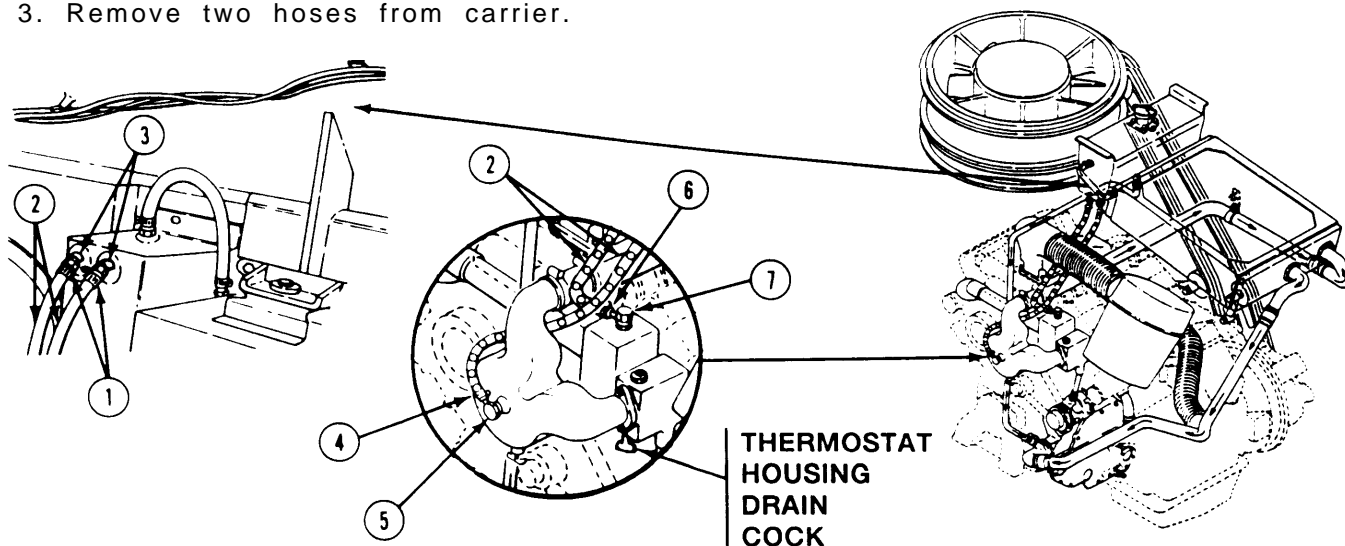

FOLLOW-THROUGH STEPS

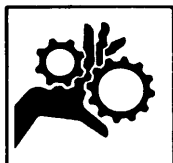

WARNING
 Wearing loose clothing around moving parts can allow personnel to get caught and cause injury or death. Tuck in loose clothing.

1. Fill cooling system (page 8-5).
2. Start engine (see your -10). Check for leaks.
3. Stop engine/shutdown (see your -10).
4. Close power plant front access door and raise trim vane (see your -10).

END OF TASK

REPLACE COMBAT FILLER COVER AND LOCK

INITIAL SETUP

Tools:

General Mechanics Tool Kit (Item 30, App D)

Materials/Parts:

Self-locking nut
Spring pin (3)

Personnel Required:

Unit Mechanic

References:

See your -10

Equipment Conditions:

Engine stopped/shutdown (see your -10)
Power plant rear access panel removed
(see your -10)

REMOVE

- Loosen wingnut (1). Remove thumbscrew (2), washer (3), and spacer (4) from power plant grill.
- Remove spring pin (5), washer (6), spring (7), and pin (8) from power plant grill. Discard spring pin.
- Remove two spring pins (9) and cover (10) from power plant grill. Discard spring pins.
- On M577A2 only, remove locknut (11), washer (12), and rod end (13) from power plant grill. Discard locknut.

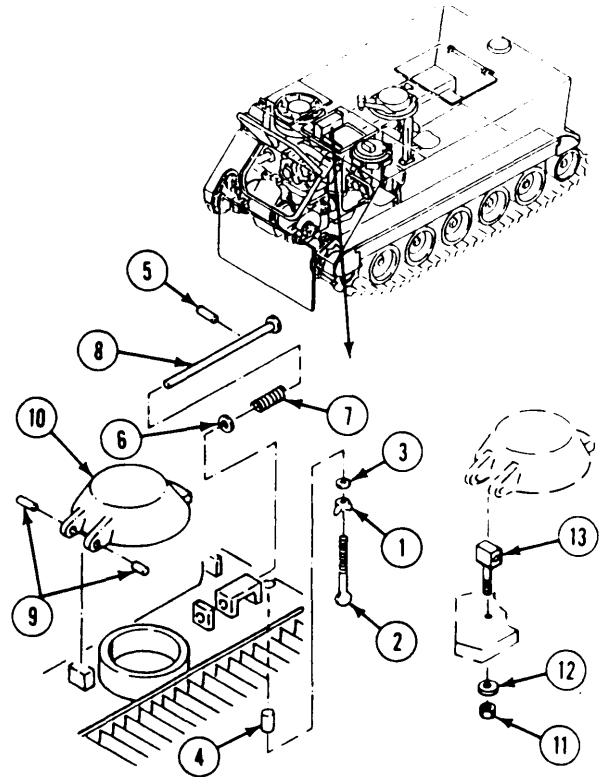

INSTALL

- Secure cover (10) to power plant grill with two new spring pins (9).
- Install pin (8) in power plant grill. Secure with spring (7), washer (6), and new spring pin (5).
- Install wingnut (1), washer (3), and spacer (4) on thumbscrew (2).

FOLLOW-THROUGH STEPS

- Install power plant rear access panel (see your -10).

END OF TASK

Section II. FAN AND DRIVE COMPONENTS

TASK INDEX

<u>Task</u>	<u>Page</u>	<u>Task</u>	<u>Page</u>
Replace Fan Drive Belts	8-35	Replace Drain Cap and Sight Gage	8-42
Replace Fan Drive Fixed Idler and Pulley	8-37	Replace Cooling Fan Assembly	8-44
Replace Fan Drive Adjustable Idler and Pulley	8-39	Replace Pulley Drive Shaft, Bearing and Housing	8-46
Replace Fan Drive Pulley and Access Cover	8-41		

REPLACE FAN DRIVE BELTS

INITIAL SETUP

Tools:

General Mechanics Tool Kit (Item 30, App D)

Materials/Parts:

Lockwasher (4)

Personnel Required:

Unit Mechanic

References:

See your -10

Equipment Conditions:

Engine stopped/shutdown (see your -10)
 Power plant rear access panel removed
 (page 24-27 or 24-29)

REMOVE

1. Remove four screws (1), flat washers (2), lockwashers (3), and fan pulley access cover (4) from power plant compartment rear bulkhead. Discard lockwashers.
2. Loosen locknut (5) that secures rod end (6) to adjusting nut (7).
3. Turn adjusting nut (7) counterclockwise to loosen drive belts (8).
4. Remove drive belts (8) from idler pulleys (9 and 10) and fan pulleys (11 and 12).

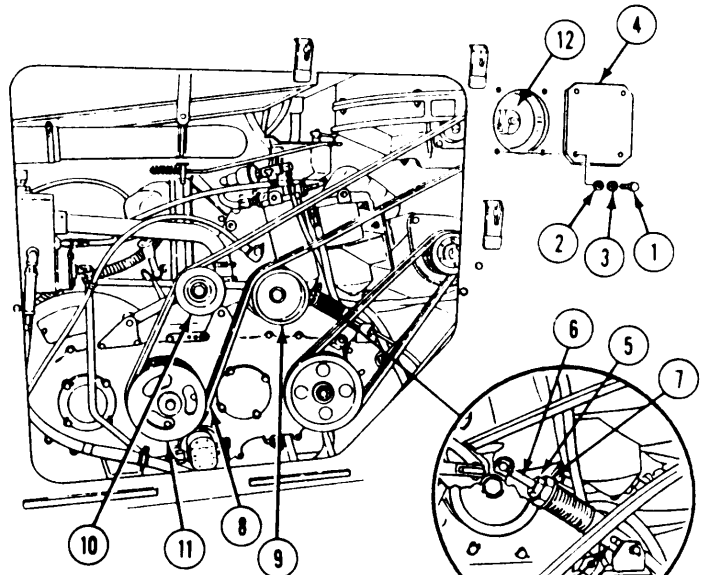

INSTALL

NOTE

Fan drive belts are to be replaced in matched sets.

5. Install drive belts (8) on fan pulleys (11 and 12) and idler pulleys (9 and 10).
6. Install fan pulley access cover (4) on power plant compartment rear bulkhead. Secure with four screws (1), flat washers (2), and new lockwashers (3).

ADJUST

7. Loosen locknut (5), if necessary, and turn adjusting nut (7) left or right until lower end of rod (6) is within operating range. Tighten locknut.

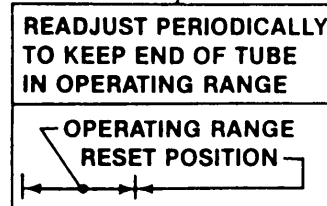
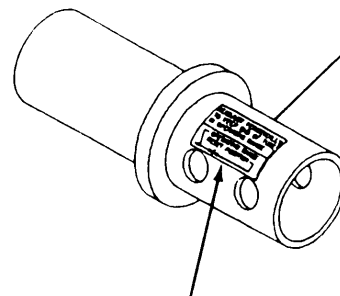

GO TO NEXT PAGE

FOLLOW-THROUGH STEPS

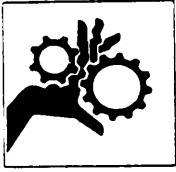

WARNING
Wearing loose clothing around moving parts can allow personnel to get caught and cause injury or death. Tuck in loose clothing.

1. Start engine (see your -10). Check for belt slippage.
2. Stop/shutdown engine (see your -10).
3. Check drive belts for proper tension (see your -10).
4. Install power plant rear access panel (page 24-27 or 24-29).

END OF TASK

REPLACE FAN DRIVE FIXED IDLER AND PULLEY

DESCRIPTION

This task covers: Remove (page 8-37). Install (page 8-38).

INITIAL SETUP

Tools:

General Mechanics Tool Kit (Item 30, App D)
 Snap ring pliers (Item 45, App D)
 Torque wrench (Item 97, App D)

Materials/Parts:

Cotter pin (2)

Personnel Required:

Unit Mechanic

References:

see your -10

Equipment Conditions:

Engine stopped/shutdown (see your -10)
 Ramp lowered (see your -10)
 Power plant rear access panel removed
 (page 24-27 or 24-29)

REMOVE

1. Remove fan drive belts (page 8-35).
2. Remove bolt (1), washer (2), nut (3) and idler pulley (4) from idler arm (5).
3. Remove two cotter pins (6), straight pins (7 and 8), and idler arm (5) from transfer gearcase. Discard cotter pins.
4. Remove two retaining rings (9), bearings (10), and spacer (11) from idler pulley (4).

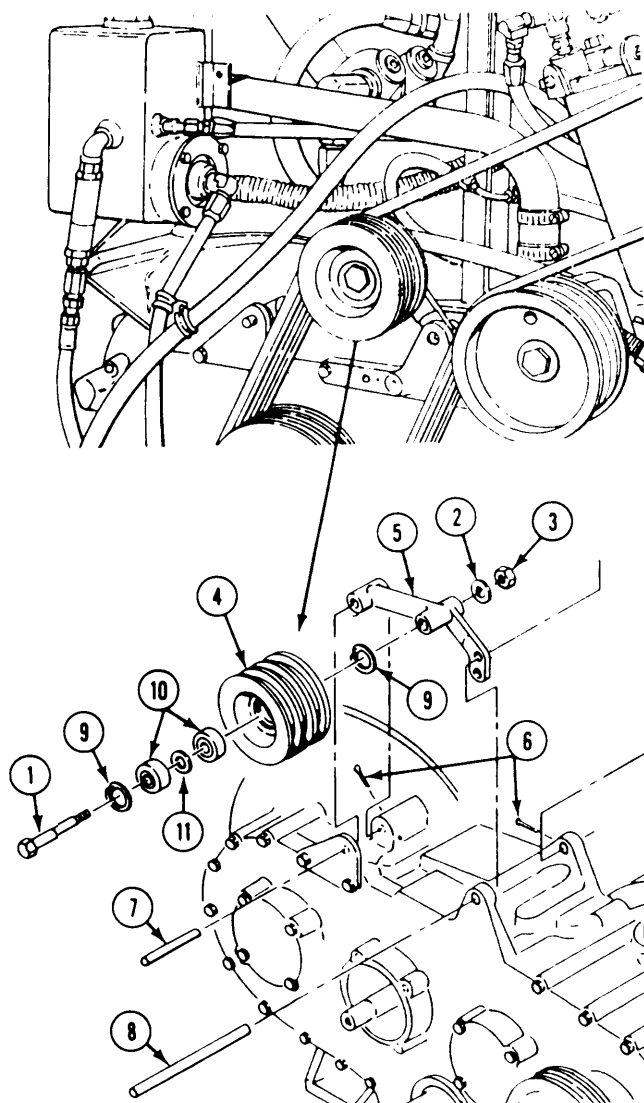

GO TO NEXT PAGE

INSTALL

5. Install spacer (1), two bearings (2), and retaining rings (3) in pulley (4). Use snap ring pliers.
6. Secure idler arm (5) to transfer gearcase with two straight pins (6 and 7) and new cotter pins (8).
7. Secure pulley (4) to idler arm (5) with screw (9), washer (10), and nut (11). Tighten nut to 50-55 lb-ft (68-77 N-m) torque. Use torque wrench.
8. Install and adjust fan drive belts (page 8-35).

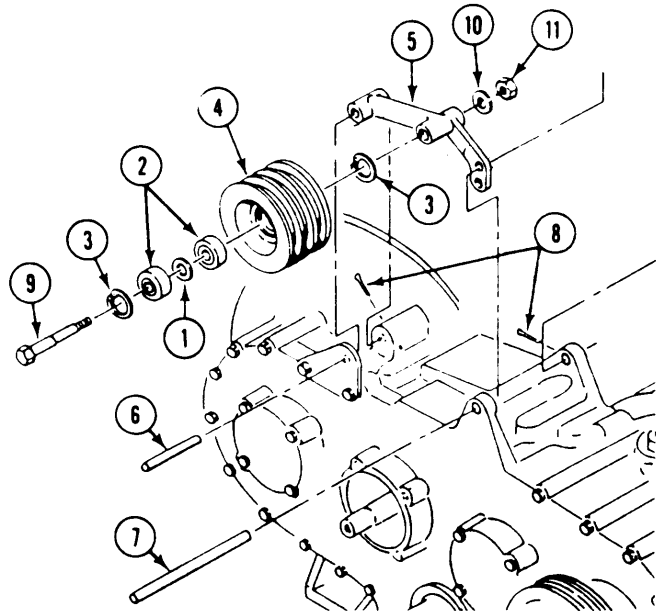

FOLLOW-THROUGH STEPS

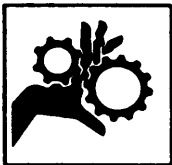

WARNING
Wearing loose clothing around moving parts can allow personnel to get caught and cause injury or death. Tuck in loose clothing.

1. Start engine (see your -10). Check fixed idler pulley and fan drive belts for proper operation.
2. Stop/shutdown engine (see your -10).
3. Install power plant rear access panel (page 24-27 or 24-29).

END OF TASK

REPLACE FAN DRIVE ADJUSTABLE IDLER AND PULLEY

DESCRIPTION

This task covers: Remove (page 8-39). Install (page 8-40).

INITIAL SETUP

Tools:

General Mechanics Tool Kit (Item 30, App D)
Snap ring pliers (Item 45, App D)
Torque wrench (Item 97, App D)

Materials/Parts:

Cotter pin (4)

Personnel Required:

Unit Mechanic

References:

See your -10

Equipment Conditions:

Engine stopped/shutdown (see your -10)
Carrier blocked (see your -10)
Ramp lowered (see your -10)
Power plant rear access panel removed
(page 24-27 or 24-29)

REMOVE

1. Remove fan drive belts (page 8-35).
2. Remove bolt (1), nut (2), washer (3), and fan idler pulley (4) from idler pulley arm (5).
3. Remove cotter pin (6), headed pin (7), and adjustable rod end (8) from idler pulley arm (5). Discard cotter pin.
4. Loosen nut (9). Remove rod end (8) and nut (9) from adjusting nut (10),
5. Remove nut (10) and spring (11) from adjusting sleeve (12).
6. Remove decal (13) from adjusting sleeve (12) only if replacement is required.
7. Remove cotter pin (14), straight pin (15), and arm (5) from transfer gearcase. Discard cotter pin.
8. Remove two cotter pins (16), straight pin (17), and sleeve (12) from transfer gearcase. Discard cotter pins.
9. Remove two retaining rings (18), bearings (19), and spacer (20) from pulley (4).

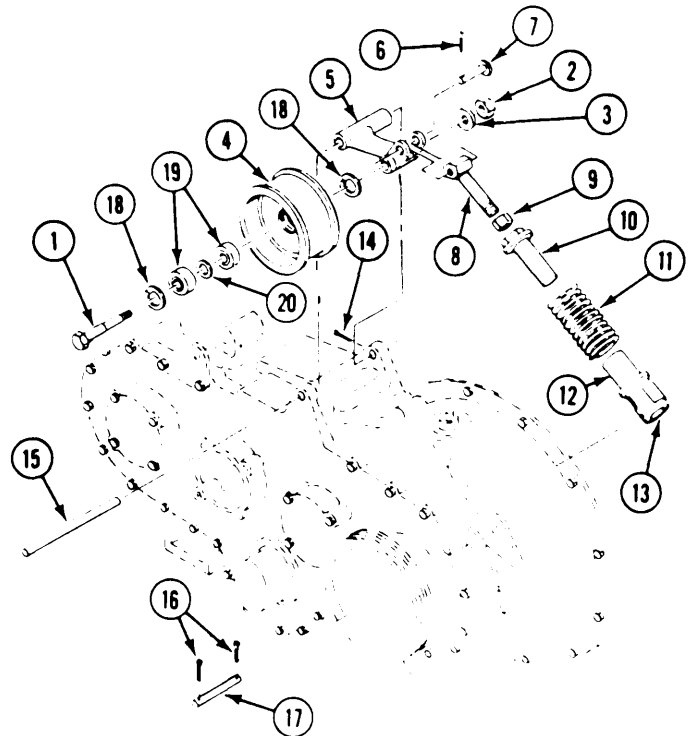

GO TO NEXT PAGE

INSTALL

10. Install two bearings (1) and spacer (2) in pulley (3), Secure with two retaining rings (4). Use snap ring pliers.
11. Install new decal (5) (page 24-217) on adjusting sleeve (6) if required.
12. Secure sleeve (6) to transfer gearcase with straight pin (7) and two new cotter pins (8).
13. Secure idler pulley arm (9) to transfer gearcase with straight pin (10) and new cotter pin (11).
14. Install nut (12) on rod end (13).
15. Install adjusting nut (14) and spring (15) on sleeve (6).
16. Install rod end (13) in nut (14).
17. Secure rod end (13) to idler pulley arm (9) with pin (16) and new cotter pin (17).
18. Secure fan idler pulley (3) to arm (9) with nut (18), washer (19), and bolt (20). Tighten nut to 50-55 lb-ft (68-75 N-m) torque. Use torque wrench.
19. Install and adjust fan drive belts (page 8-35).

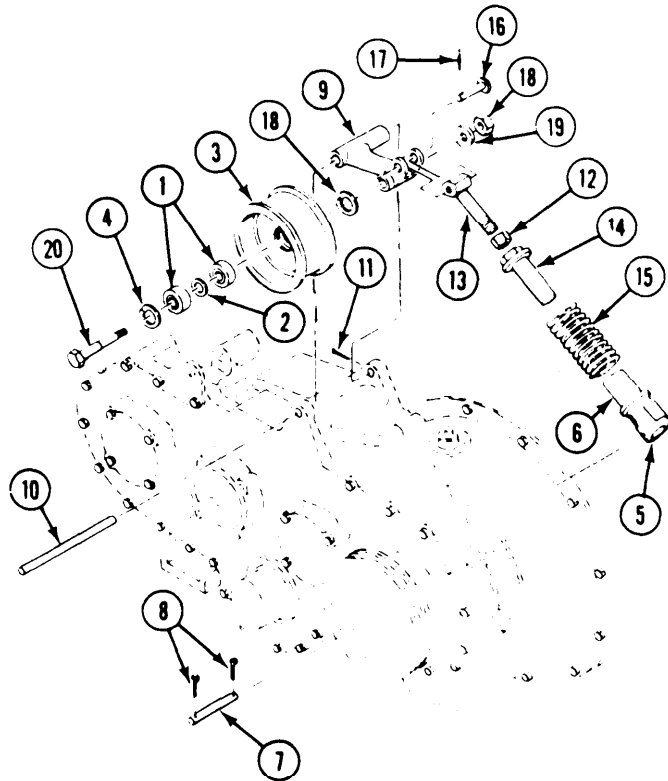

FOLLOW-THROUGH STEPS

- | | |
|--|---|
| <ol style="list-style-type: none"> 1. Start engine (see your -10). Check adjustable idler and fan drive belts for proper operation. 2. Raise and lock ramp (see your -10). | <ol style="list-style-type: none"> 3. Engine stopped/shutdown (see your -10). 4. Install power plant rear access panel (page 24-27 or 24-29). |
|--|---|
-

END OF TASK

REPLACE FAN DRIVE PULLEY AND ACCESS COVER

INITIAL SETUP

Tools:

- General Mechanics Tool Kit (Item 30, App D)
- Torque Wrench Adapter (Item 9, App D)
- Torque Wrench (Item 95, App D)

Materials/Parts:

- Lockwasher (4)

Personnel Required:

- Unit Mechanic
-

References:

- see your -10

Equipment Conditions:

- Engine stopped/shutdown (see your -10)
- Carrier blocked (see your -10)
- Power plant rear access panel removed (page 24-27 or 24-29)

REMOVE

1. Remove four screws (1), flat washers (2), lockwashers (3), and fan pulley access cover (4) from power plant compartment rear bulkhead. Discard l&washers.
2. Remove fan drive belts (page 8-35).
3. Remove nut (5), screw (6), pulley (7), and key (8) from shaft (9).

7. Using torque wrench adapter, tighten nut (5) to 300-360 lb-in (34-41 N•m) torque. Use torque wrench.
8. Secure cover (4) to power plant compartment rear bulkhead with four flat washers (2), new lockwashers (3), and screws (1).

INSTALL

NOTE

-Place pulley (7) on fan shaft (9) with the bolt and nut facing down as shown. Install key (8) making sure key is flush with ends of pulley and fan shaft. This will insure proper alignment and pulley balance.

4. Install key (8) and pulley (7) on fan shaft (9). Secure with screw (6) and nut (5) in pulley hub. Do not tighten nut (5) at this time.
5. Install and adjust fan drive belts (page 8-35).
6. Align groove of pulley (7) with grooves of idler pulley and fan drive pulley.

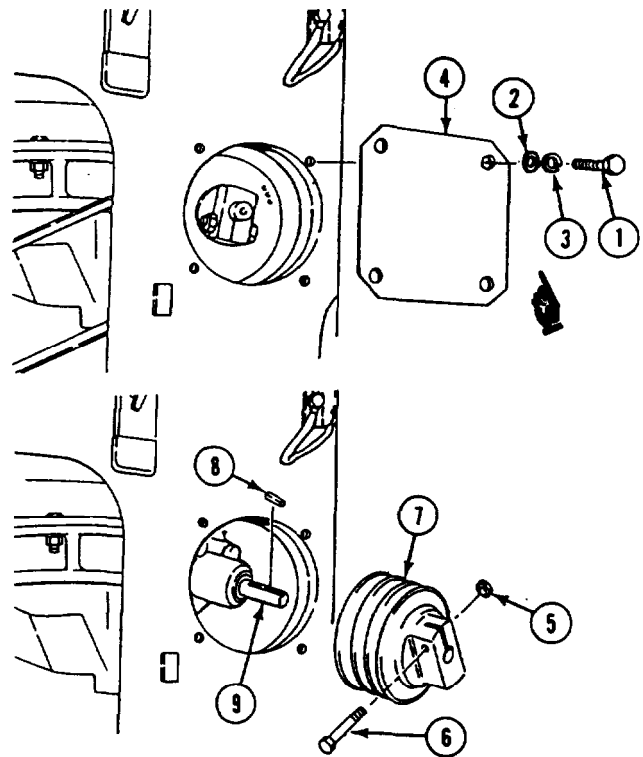

FOLLOW-THROUGH STEPS

1. Install power plant rear access panel (page 24-27 or 24-29).
-

END OF TASK

REPLACE DRAIN CAP AND SIGHT GAGE

INITIAL SETUP

Tools:

General Mechanics Tool Kit (Item 30, App D)
Torque Wrench (Item 99, App D)

References:

See your - 10
See your LO

Materials/Parts:

Antiseize compound (Item 4, App C)
Nonelectrical wire (Item 31, App C)
Packing (2)
Suitable container

Equipment Conditions:

Engine stopped/shutdown (see your -10)
Power plant rear access panel removed
(page 24-27 or 24-29)
Carrier blocked (see your -10)

Personnel Required:

Unit Mechanic

REMOVE

1. Place suitable container under drain cap (1). Remove cap, packing (2) and lockwire (3), and drain oil. Discard wire and packing.
2. Remove lockwire (4), four screws (5), washers (6), cover (7) and packing (8) from fan gearbox (9). Discard lockwire and packing.
3. Remove filler plug (10) from fan gearbox (9).

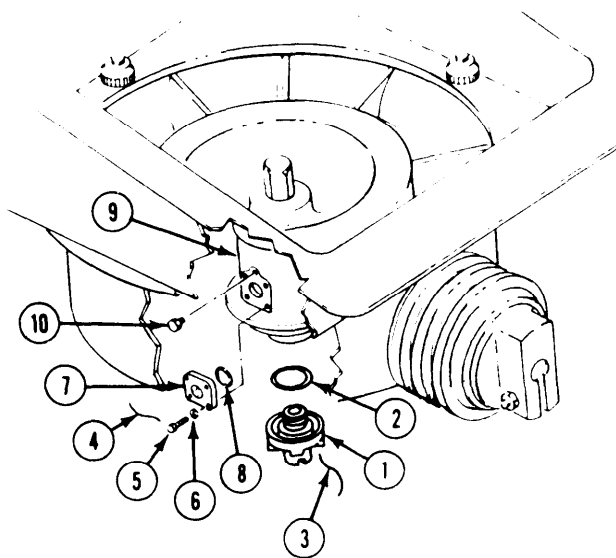

INSTALL

4. Install new packing (2) in fan gearbox (9).
5. Install drain cap (1) on fan gearbox (9).
6. Install new lockwire (3) through drain cap (1) and fan gearbox (9). Twist lockwire.
7. Apply antiseize compound to threads of screws (5) and plug (10).
8. Fill fan gearbox with oil.
9. Install plug (10) in fan gearbox (9).
10. Install new packing (8) and cover (7) on fan gearbox (9). Secure with four washers (6) and screws (5). Tighten screws to 42-48 in-lb (4.7-5.4 N-m) torque. Use torque wrench.
11. Secure four screws (5) with new lockwire (4). Double twist lockwire as shown below.

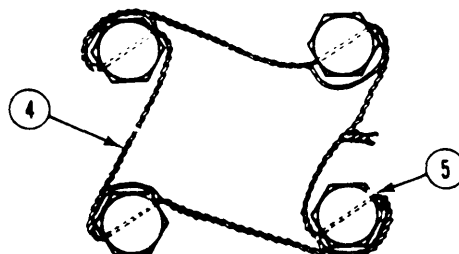

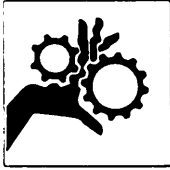
FOLLOW-THROUGH STEPS**WARNING**

Startup of equipment or moving parts could injure you or others. If other personnel are working on your carrier, be sure you know what they are doing. Place

DO NOT OPERATE tags on **MASTER SWITCH** when needed to prevent startup.

1. Start engine and check fan for proper operation (see your -10).
2. Stop/shutdown engine (see your -10).
3. Install power plant rear access panel (page 24-27 or 24-29).

END OF TASK

REPLACE COOLING FAN ASSEMBLY

DESCRIPTION

This task covers: Remove (page 8-44). Install (page 8-45).

INITIAL, SETUP

Tools:

General Mechanics Tool Kit (Item 30, App D)
 Endless Sling (Item 64, App D)
 Socket Wrench Set (Item 89, App D)
 Torque Wrench (Item 95, App D)

Materials/Parts:

Decal, if needed
 Suitable container

Personnel Required:

Unit Mechanic

Personnel Required (cont):

Helper (H)

References

see your -10
 see your LO

Equipment Conditions:

Engine stopped/shutdown (see your -10)
 Carrier blocked (see your -10)
 Power plant grill raised (page 5-2)

REMOVE

WARNING

Cooling fan is heavy and can cause back injury if handled improperly. Be sure to use a hoist or helper to remove cooling fan.



1. Attach sling and suitable lifting device of at least 150 lbs (45 kg) capacity to fan assembly.
2. Remove six screws (1) and washers (2) that secure fan assembly (3) to power plant grill (4).
3. Lift fan assembly (3) from power plant grill (4) and place fan assembly on work bench or a flat wooden board.
4. Remove fan drive pulley (5) from fan assembly (3) (page 8-41).
5. Remove plug (6) and packing (7) from right angle gearbox (8) use suitable container and drain gearbox (see your LO).
6. If decal (9) is damaged or unreadable, remove it.

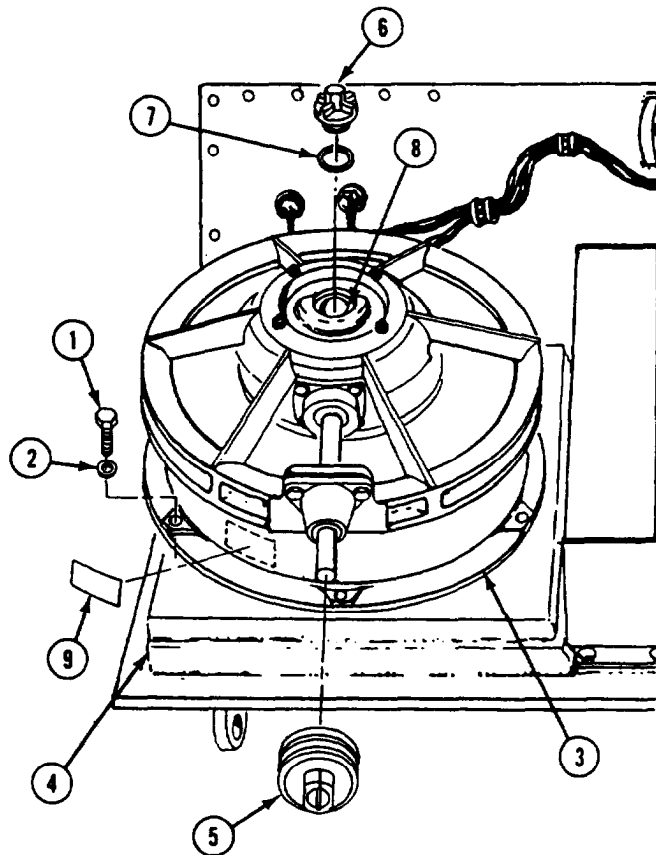

INSTALL**WARNING**

Cooling fan is heavy and can cause back injury if handled improperly. Be sure to use a hoist or helper to install cooling fan.

7. Fill fan drive right angle gearbox (1) if required (see your LO).
8. Install packing (2) and plug (3) on right angle gearbox (1).
9. Install fan drive pulley (8) on fan assembly (4) (page 8-41).
10. Attach sling and suitable lifting device of at least 150 lbs (45 kg) capacity to fan assembly. Lift fan assembly (4) and install on power plant grill (5).
11. Install six screws (6) and washers (7). Tighten screws to 292-336 lb-in (33-38 N·m) torque. Use torque wrench and socket wrench set.
12. If removed, install new decal (9)

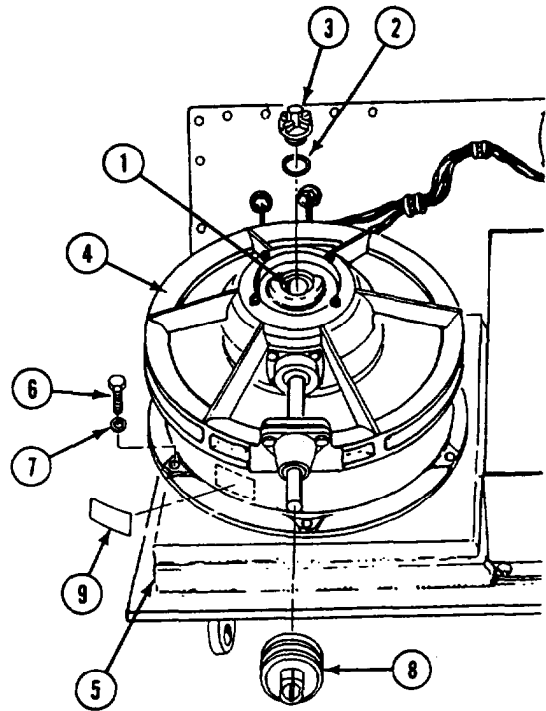
**FOLLOW-THROUGH STEPS**

1. Lower power plant grill (page 5-2).

END OF TASK

REPLACE PULLEY DRIVE SHAFT, BEARING, AND HOUSING

DESCRIPTION

This task covers: Remove (page 8-46). Install (8-47).

INITIAL SETUP

Tools:

General Mechanics Tool Kit (Item 30, App D)
Torque Wrench (Item 95, App D)
Snap Ring Pliers (Item 45, App D)

Materials/Parts:

Key washer (3)
Lockring
Packing

Personnel Required:

Unit Mechanic

References:

See your -10

Equipment Conditions:

Engine stopped/shutdown (see your -10)
Ramp lowered (see your -10)
Power plant rear access panel removed (page 24-27 or 24-29)
Front ammunition rack removed (M106A2 and M125A2 only) (page 24-188)
Personnel heater removed (M106A2 and M125A2 only) (page 29-51)
Fan drive-belts removed (page 8-35)
Fan pulley access cover removed (page 8-41)
Fan pulley removed from fan drive shaft (page 8-41)

REMOVE

1. Remove three screws (1), key washers (2), and housing (3) from support (4). Discard key washers.
2. Remove bearing (5), and drive shaft (6) from housing (3).
3. Loosen setscrew (7) in collar (8) and separate collar from bearing (5).
4. Remove drive shaft (6) from housing (3), bearing (5) and collar (8).
5. Remove lockring (9) and packing (10) from drive shaft (6). Discard packing and lockring.
6. Remove bearing (5) from housing (3) by tapping bearing on outer edge until the bearing rotates in the housing.

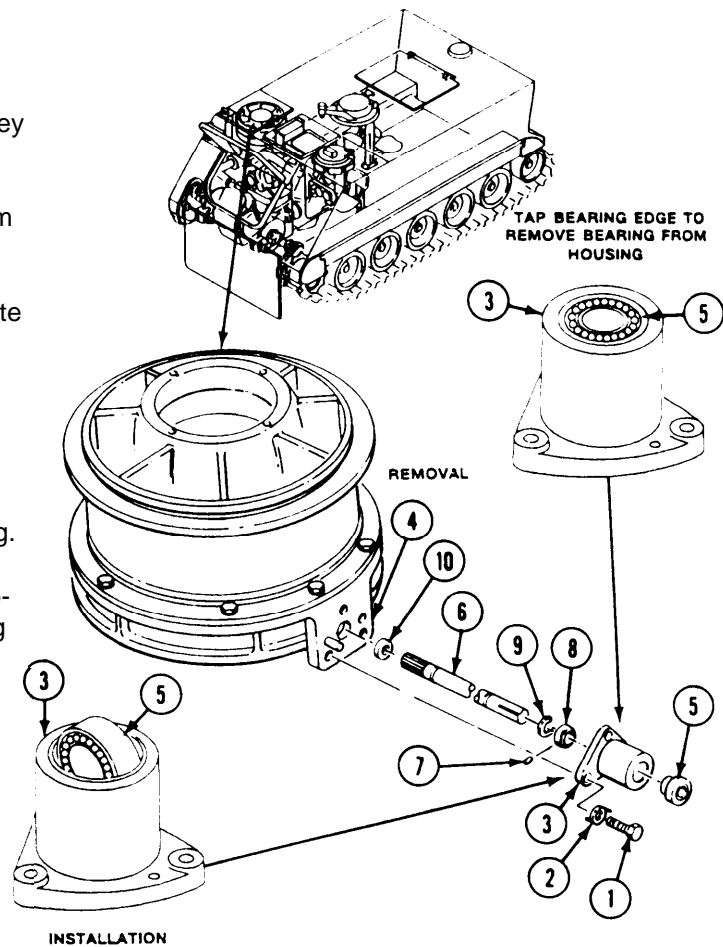

INSTALL

7. Install bearing (1) in housing (2) and tap outer edge of bearing until seated in housing.
8. Install new lockring (3) and new packing (4) on drive shaft (5). Use snap ring pliers.
9. Slide collar (6), housing (2) and bearing (1) to lockring (3) on drive shaft (5).
10. Turn collar (6) onto bearing (1) to lock bearing to drive shaft (5), Tighten setscrew (7) in collar (6).
11. Align splines and install drive shaft (5) through support (8) opening into fan gear-box.
12. Secure housing (2) to support (8) with three new key washers (9) and screws (10). Tighten screws to 300-360 lb-in (34-41 N-m) torque. Use torque wrench.

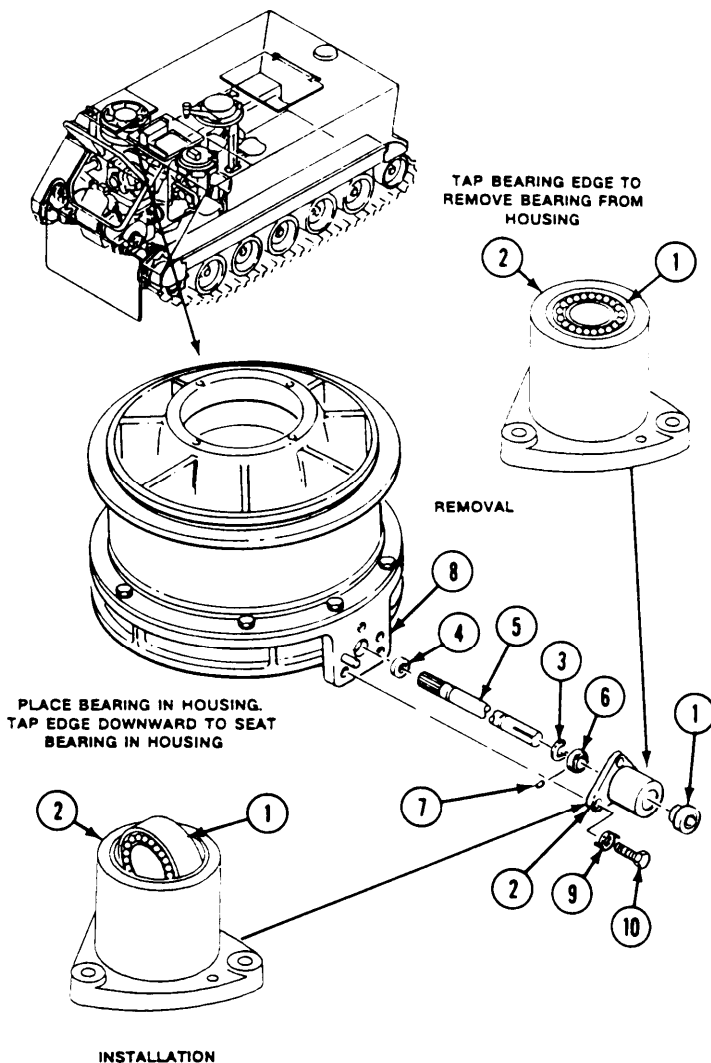

FOLLOW-THROUGH STEPS

1. Install fan pulley (page 8-41).
2. Install fan drive belts (page 8-35).
3. Install fan pulley access cover (page 8-41).
4. Adjust fan drive belt tension (page 8-35).
5. Install power plant rear access panel (page 24-27 or 24-29).
6. Install personnel heater (M106A2 and M125A2 only) (page 28-52).
7. Install front ammunition rack (M106A2 and M125A2 only) (page 24-188).
8. Raise and lock ramp (see your -10).
9. Stop/shutdown engine (see your -10).

END OF TASK

CHAPTER 9
ELECTRICAL SYSTEM MAINTENANCE - POWER RECEPTACLES
GENERATOR, AND REGUIATOR

Section I. AUXILIARY POWER RECEPTACLES

TASK INDEX

<u>Task</u>	<u>Page</u>	<u>Task</u>	<u>Page</u>
■ Replace Auxiliary Power (Slave) Receptacle (All Except M577A2 and M1068)9-2		Replace Nato Auxiliary Power (Slave) Receptacle (M577A2 and M1068 Only)9-10 ■	
■ Replace Auxiliary Power (Slave) Receptacle (M577A2 and M1068 Only)9-6			

REPLACE AUXILIARY POWER (SLAVE) RECEPTACLE (ALL EXCEPT M577A2 AND M1068)

DESCRIPTION

This task covers: Remove (page 9-2). Install (page 9-4).

INITIAL SETUP

Tools:

General Mechanics Tool Kit (Item 30, App D)

Personnel Required:

Unit Mechanic

Materials/Parts:

Gasket
Grommet
Lockwasher (early model)
Lockwasher (2) (late model)
Self-locking nut (4) (early model)
Self-locking nut (8) (early model)
Self-locking nut (4) (late model)
Self-locking nut (8) (late model)

References:

see your -10

Equipment Conditions:

Engine stopped/shutdown (see your -10)
Carrier blocked (see your -10)
Battery ground lead disconnected (page 13-2)

REMOVE

NOTE

Steps 1 through 5 tell you how to remove the early model slave receptacles. Steps 6 through 13 tell you how to remove the late model slave receptacles.

1. Remove eight locknuts (1), washers (2), and screws (3) from master switch panel (4). Pull panel away from distribution box. Discard locknuts.

2. Remove nut (5), circuit 49 lead (6), two washers (7), and screw (8) from terminal on circuit 50 lead (9).

3. Loosen nut (10) and lockwasher (11) on master switch (12). Remove lead (9) from master switch terminal. Discard lockwasher.

4. Remove nut (13), washer (14), screw (15), and ground lead (16) from instrument panel strut hull mount.

5. Remove four nuts (17), screws (18), receptacle (19), and grommet (20) from panel (4). Remove grommet from ground lead (16). Discard grommet.

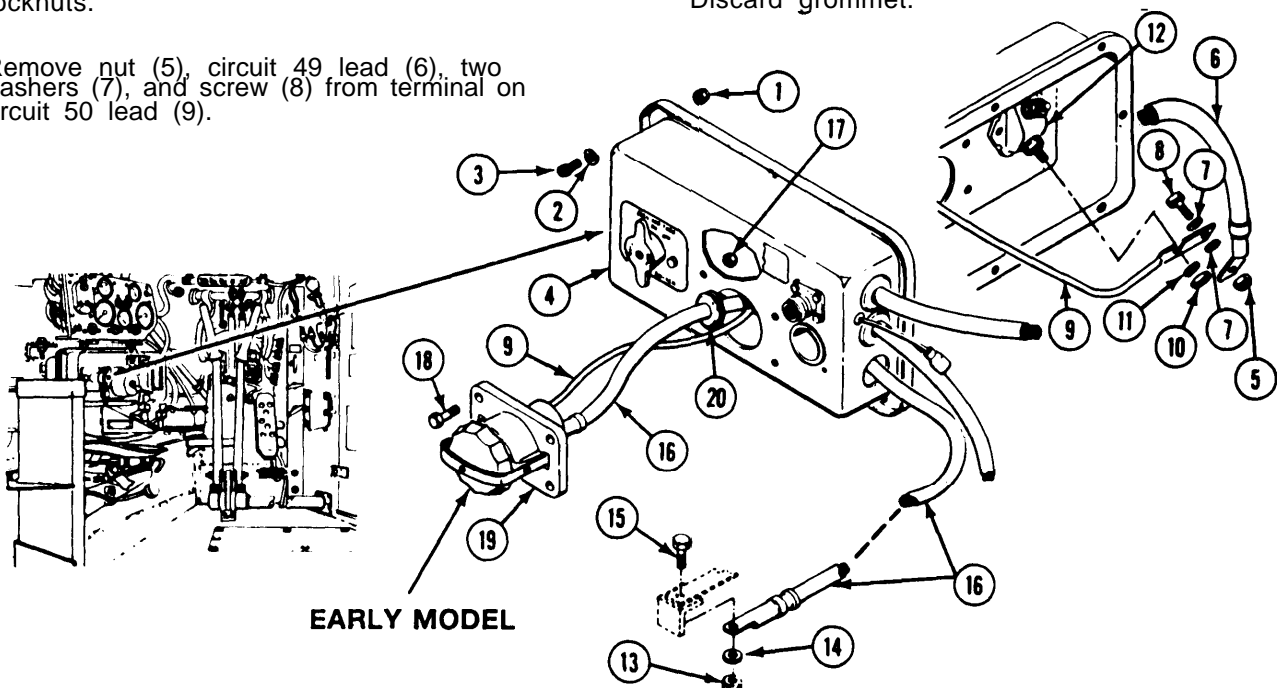

EARLY MODEL

6. Disconnect circuit 37 lead (1) from connector (12).
7. Remove eight locknuts (3), washers (4), and screws (5) from master switch panel (6). Pull panel away from distribution box. Discard locknuts.
8. Remove screw (7), lockwasher (8), and circuit 50 lead (9) from positive post (10) of auxiliary power receptacle (11). Discard lockwasher.
9. Remove screw (12), lockwasher (13), and ground lead (14) from negative post (15) of auxiliary power receptacle (11). Discard lockwasher.
10. Remove four screws (16), washers (17), locknuts (18), and auxiliary power receptacle (11) from master switch panel (6). Discard locknuts.
11. Remove nut (19) and washer (20) on master switch (21). Remove circuit 50 lead (9) and circuit 49 lead (22) from master switch terminal (23).
12. Remove nut (24), washer (25), screw (26), and ground lead (14) from instrument panel strut hull mount.
13. Remove gasket (27), insulator (28), and grommet (29) from master switch panel (6). Remove grommet from ground lead (14). Discard grommet and gasket:

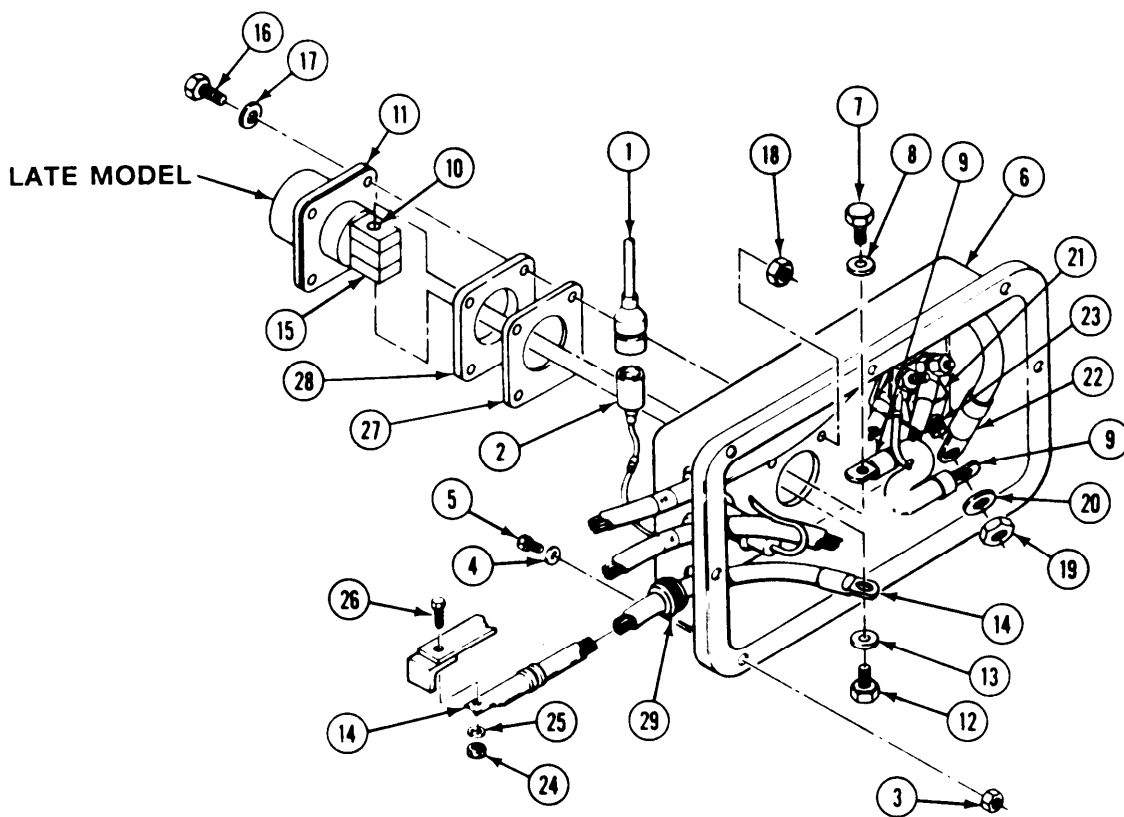

GO TO NEXT PAGE

INSTALL

NOTE

Steps 14 through 21 tell you how to install the late model slave receptacles. Steps 22 through 27 tell you how to install the early model slave receptacles.

Make sure protective cap retaining cord is attached to receptacle lower mount screw.

14. Install insulator (1), new gasket (2), and auxiliary power receptacle (3) in master switch panel (4). Secure with four screws (5), washers (6), and new locknuts (7).
15. Install new grommet (8) on ground lead (9). Route lead out of master switch panel (4). Install grommet in panel.
16. Place ground lead (9) on instrument panel strut hull mount. Secure with screw (10), washer (11) and nut (12).
17. Install circuit 50 lead (13) and circuit 49 lead (14) on terminal of master switch (15). Secure with washer (16) and nut (17).
18. Install ground lead (9) on negative post (18) of auxiliary power receptacle (3). Secure with screw (19) and new lockwasher (20).
19. Install circuit 50 lead (13) on positive post (21) of auxiliary power receptacle (3). Secure with screw (22) and new lockwasher (23).
20. Install master switch panel (4) on distribution box. Secure with eight screws (24), washers (25), and new locknuts (26).
21. Connect circuit 37 lead (27) to connector (28).

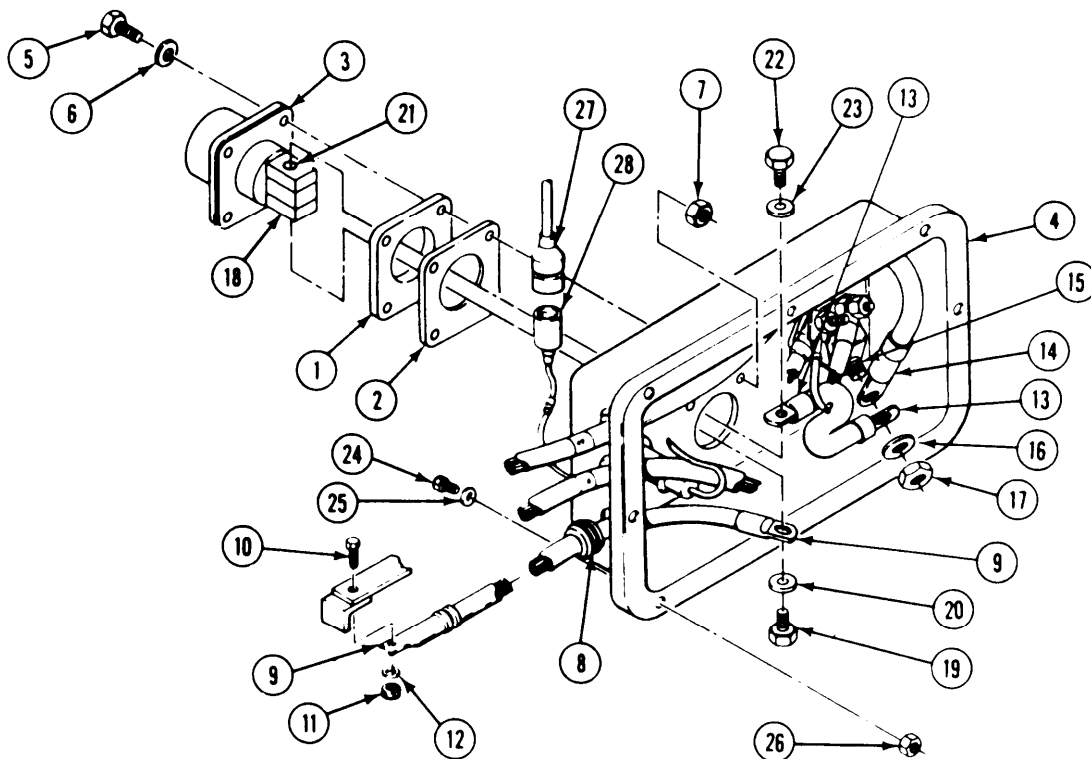

22. Install power receptacle (1) in master switch panel (2). Secure with four screws (3) and nuts (4).
23. Install new grommet (5) on ground lead (6). Route lead out of panel (2). Install grommet in panel.
24. Place lead (6) on instrument panel strut hull mount, Secure with screw (7), washer (8), and nut (9).
25. Install circuit 50 lead (10) on terminal of master switch (11). Secure with new lockwasher (12) and nut (13).
26. Place circuit 49 lead (14) on terminal on lead (10). Secure with screw (15), two washers (16), and nut (17).
27. Place master switch panel (2) on distribution box. Secure with eight screws (18), washers (19), and eight new locknuts (20).

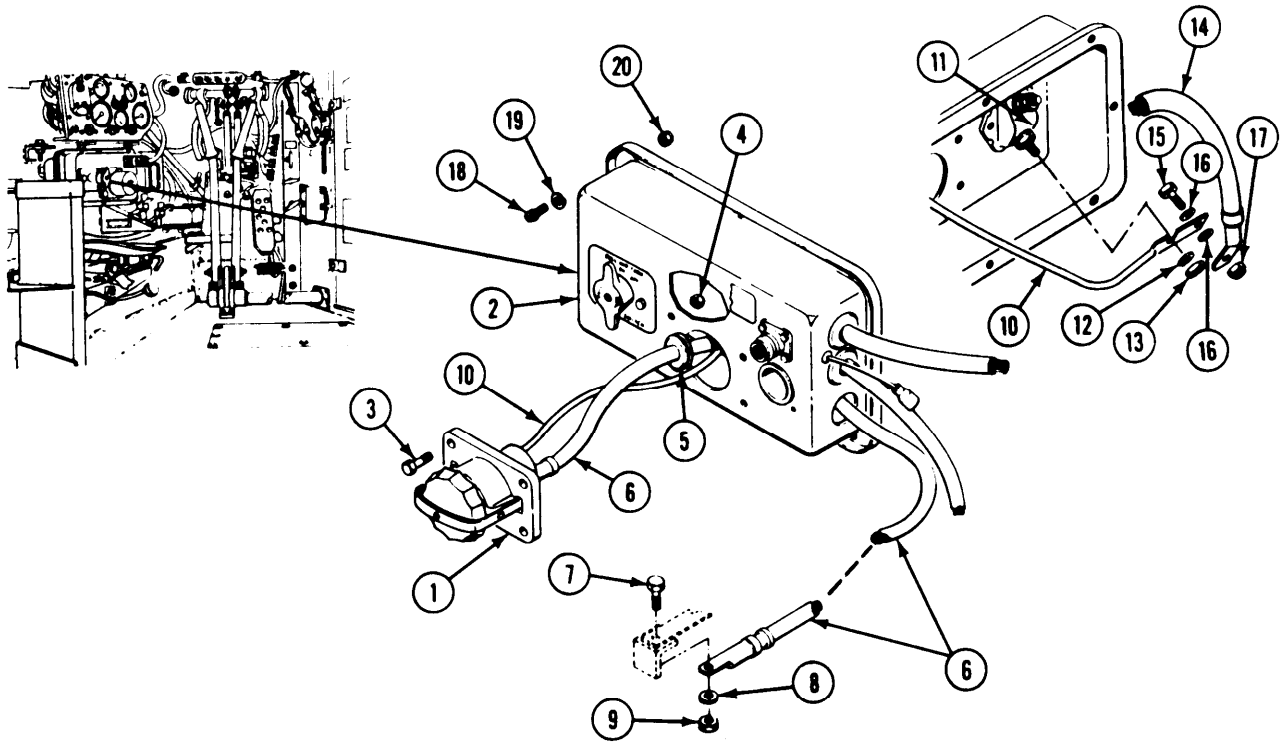

FOLLOW-THROUGH STEPS

1. Connect battery ground lead (page 13-2).
-

REPLACE AUXILIARY POWER (SLAVE) RECEPTACLE (M577A2 AND M1068 ONLY)

DESCRIPTION

This task covers: Remove (page 9-6). Install (page 9-8).

INITIAL SETUP

Tools:

General Mechanics Tool Kit (Item 30, App D)
Soldering Torch Kit (Item 68, App D)
Multimeter (Item 43, App D)

Materials/Parts

Solder, tin alloy (Item 57, App C)
Adapter gasket (late model)
Bushing (late model)
Gasket (late model)
Lockwashers (7) (early model)
Lockwashers (1) (early model)
Lockwashers (4) (early model)
Lockwashers (11) (late model)
Lockwashers (1) (late model)
Lockwashers (4) (late model)

Personnel Required:

Unit Mechanic

References:

see your -10

Equipment Conditions:

Engine stopped (see your -10)
Carrier blocked (see your -10)
Battery ground lead disconnected (page 13-2)

REMOVE

NOTE

Steps 1 through 4 tell you how to remove the early model slave receptacles. Steps 5 through 13 tell you how to remove the late model slave receptacles.

1. Remove seven screws (1), lockwashers (2), washers (3), and guard (4) from hull interior. Discard lockwashers.

2. Remove four screws (5), lockwashers (6), and washers (7) from receptacle (8). Discard lockwashers.
3. Remove screw (9), washer (10), clamp (11), and circuit 50 lead (12) from hull weldnut.
4. Pull receptacle (8) away from hull. Unsolder circuit 6 lead (13) from receptacle. Remove receptacle. Use soldering torch.

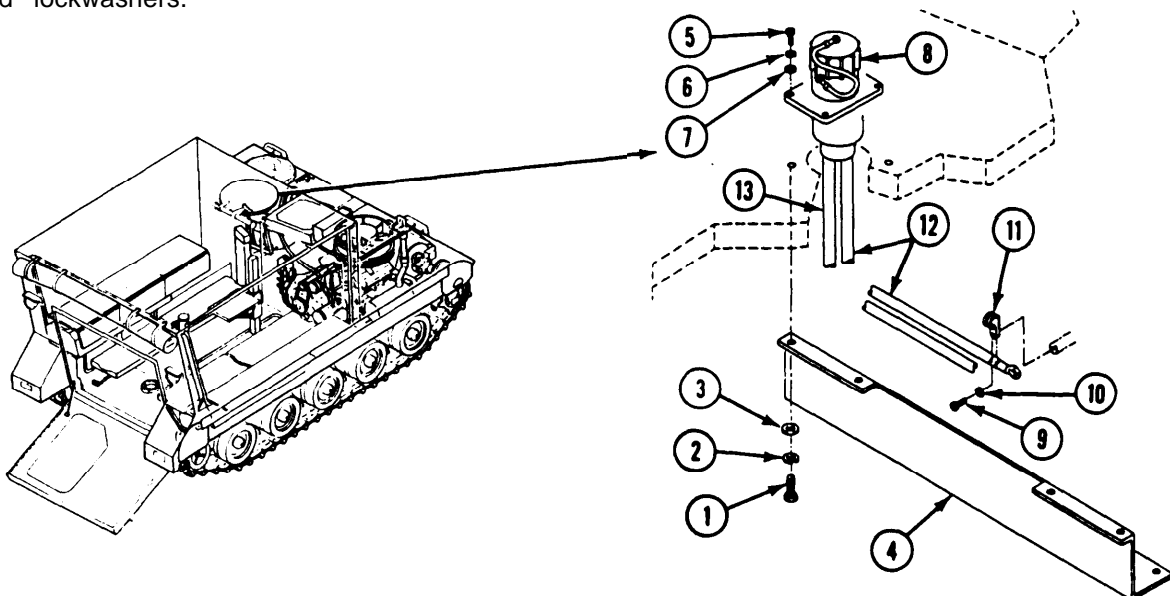

5. Remove seven screws (1), lockwashers (2), washers (3), and guard (4) from hull interior behind driver's hatch. Discard lockwashers.
6. Remove screw (5) and lockwasher (6) from clamp (7) securing ground lead (8) to hull. Discard lockwasher.
7. Remove clip (9) from wiring cradle (10) on hull. Free up ground lead (8) from cradle and clip.
8. Remove four screws (11), lockwashers (12), and washers (13) securing receptacle (14) to adapter (15) or hull. Discard lockwashers.
9. Push down on bushing (16) inserted into adapter (15) or hull. Pull receptacle (14) up far enough to expose screws (17) and leads (8 and 18) attached.
10. Remove screw (17), lockwasher (19), and circuit 6 lead (18) from positive (+) side of post on receptacle (14). Discard lockwasher.
11. Remove receptacle (14) and bushing (16) from hull. Remove screw (17), lockwasher (19), and ground lead (8) from negative (-) side of post on receptacle (14). Discard lockwasher and bushing.

NOTE

Perform step 12 only if the receptacle is mounted on an adapter (15).

12. If adapter (15) is used, remove four screws (20), lockwashers (21), washers (22), adapter (15) with bushing (16), and gasket (23) from hull. Discard gasket, bushing, and lockwashers.
13. Remove gasket (24) and plate insulator (25) from adapter (15). Discard gasket.

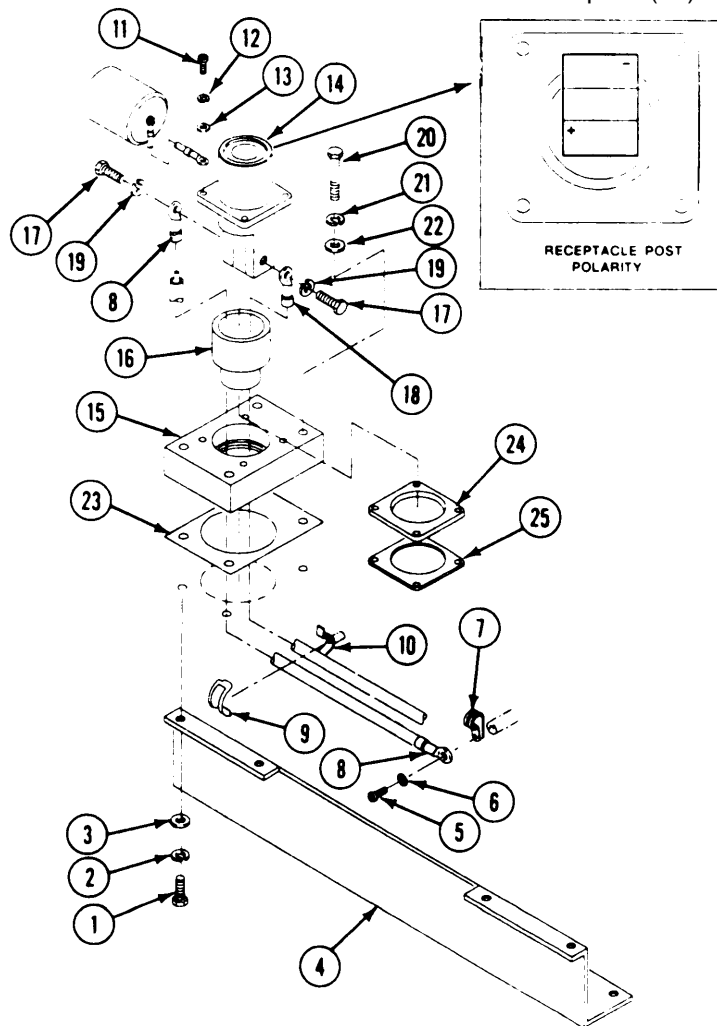

GO TO NEXT PAGE

INSTALL

NOTE

Steps 14 through 21 tell you how to install the late model slave receptacles. Steps 22 through 24 tell you how to install the early model slave receptacles.

Perform step 14 only if the receptacle is mounted on an adapter (1).

14. If adapter (1) is used, place new gasket (2) and adapter (1) on hull. Secure with four washers (3), four new lockwashers (4), and screws (5).
15. Install new bushing (6) in adapter (1) or hull.
16. Connect ground lead (7) to negative (-) side of post on receptacle (8). Secure with screw (9) and new lockwasher (10).
17. Place plate insulator (11) and new gasket (12) on adapter (1) or hull.
18. Insert ground lead (7) into bushing (6) far enough to connect circuit 6 lead (13) to positive (+) side of post on receptacle (8). Secure with screw (9) and new lockwasher (10).
19. Secure receptacle (8) with plate insulator (11) and gasket (12) to adapter (1) or hull with four screws (14), four new lockwashers (15), and four washers (16).
20. Inside carrier, install ground lead (7) to hull. Secure with screw (17) and new lockwasher (18) to clamp (19).
21. Inside carrier, fit ground lead (7) into wiring cradle (20). Secure with clip (21).

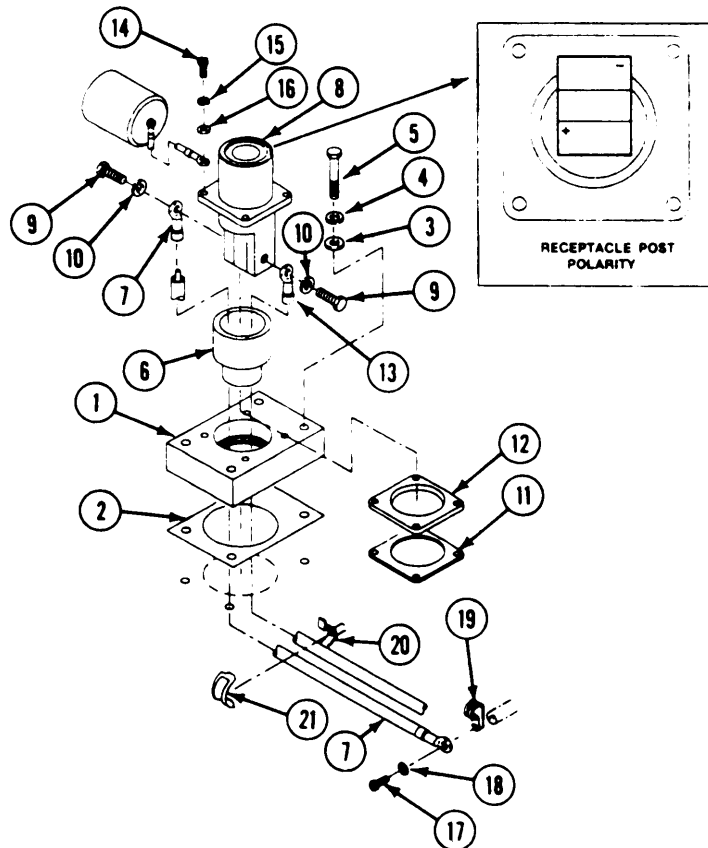

22. Place circuit 6 lead (1) in solder well of receptacle (2) and solder lead. Use soldering torch.
23. Place receptacle (2) on hull. Secure with four washers (3), new lo&washers (4), and screws (5).
24. Place circuit 50 lead (6) and clamp (7) on hull weldnut. Secure with washer (8) and screw (9).
25. Install guard (10) on hull. Secure with seven screws (11), seven new lockwashers (12), and seven washers (13).

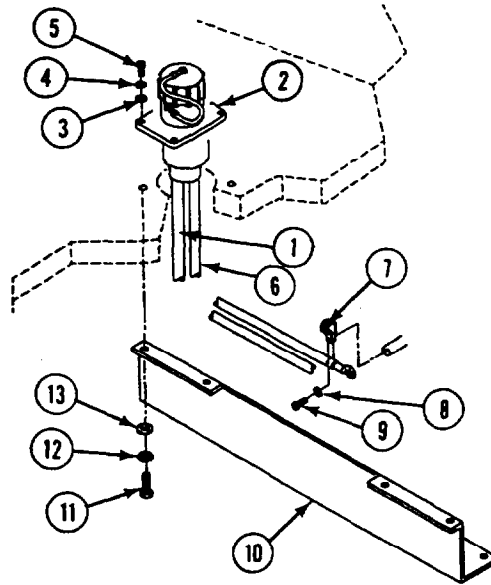

FOLLOW-THROUGH STEPS

1. Connect battery ground lead (page 13-2).
2. Check receptacle for electrical continuity. Use multimeter.

END OF TASK

**REPLACE NATO AUXILIARY POWER (SLAVE) RECEPTACLE
(M577A2 AND M1068 ONLY)**

DESCRIPTION

This task covers: Remove (page 9-10). Install (page 9-11).

INITIAL SETUP

Tools

General Mechanics Tool Kit (Item 30, App D)

Materials/Parts

- Gasket
- Gasket
- Lockwasher (4)
- Lockwasher (4)
- Lockwasher (7)
- Lockwasher (2)

Personnel Required

Unit Mechanic

References

see your -10

Equipment Conditions

Engine stopped/shutdown (See your -10).
Battery ground lead disconnected (page 13-2)

REMOVE

1. Remove seven screws (1), lockwashers (2), washers (3), and harness protector (4) from hull. Discard lockwashers.
2. Remove screw (5), washer (6), clamp (7), and circuit 50 lead (8) from hull weldnut.
3. Remove four screws (9), lockwashers (10), and washers (11) from receptacle (12). Discard lockwashers.
4. Pull receptacle (12) and adapter (13) away from hull.
5. Remove screw (14), lockwasher (15), and circuit 6 lead (16) from positive terminal of receptacle (12). Discard lockwashers.
6. Remove screw (17), lockwasher (18), and circuit 50 lead (8) from negative terminal of receptacle (12). Discard lockwashers.
7. Remove four screws (19), lockwashers (20), and washers (21) from adapter (13). Discard lockwashers.
8. Remove receptacle (12), gasket (22), insulator (23), adapter (13), and gasket (24) from hull. Discard gaskets.
9. Remove insulator bushing (25) from adapter (13).

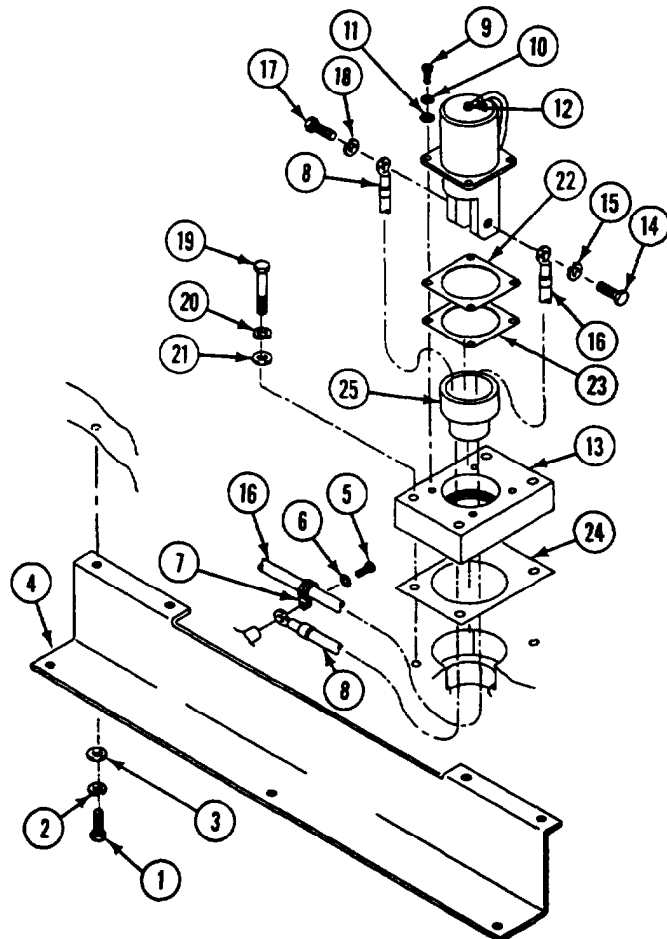

INSTALL

- 10. Install insulator bushing (1) in adapter (2).
- 11. Install receptacle (3) new gasket (4), insulator (5), adapter (2), and new gasket (6) on hull.
- 12. Connect circuit 6 lead (7) to positive terminal of receptacle (3) with new lockwasher (8) and screw (9).
- 13. Connect circuit 50 lead (10) to negative terminal of receptacle (3) with new lockwasher (11) and screw (12).
- 14. Position new gasket (6) and adapter (2) on hull and secure with four screws (13), new lockwashers (14), and washers (15).
- 15. Align receptacle (3), new gasket (4), and insulator (5) with adapter (2). Install four screws (16), new lockwashers (17), and washers (18).
- 16. Place circuit 50 lead (10) and clamp (19) on hull weldnut. Secure with washer (20) and screw (21).
- 17. Position harness protector (22) and secure with seven screws (23), new lockwashers (24), and washers (25).

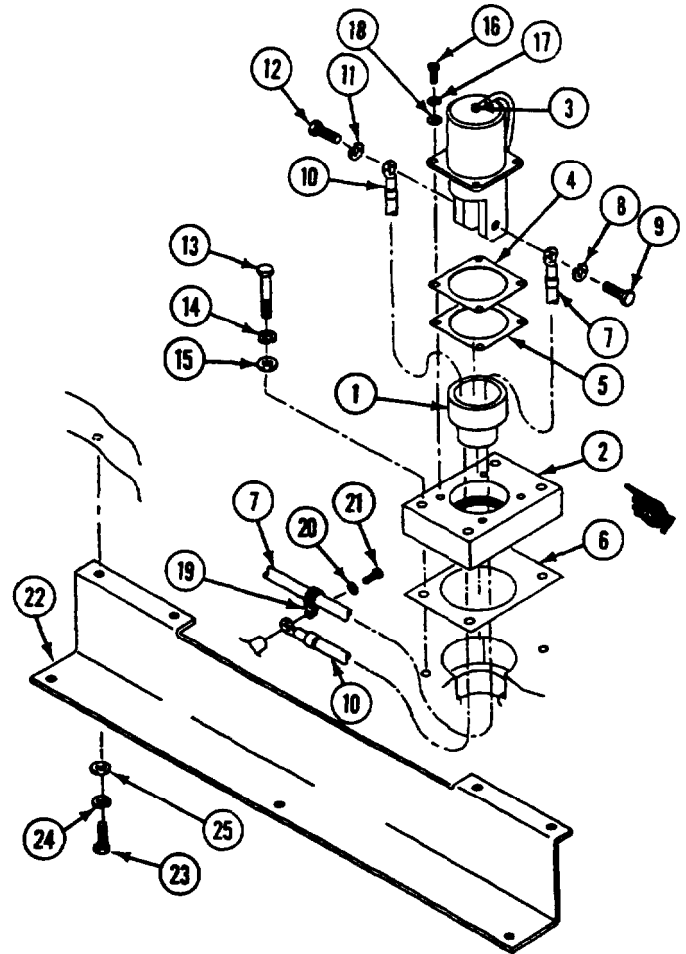

FOLLOW-THROUGH STEPS

- 1. Connect battery ground lead (page 13-2).
 - 2. Check receptacle for electrical continuity (page 3-5).
-

END OF TASK

Section II. MAINTENANCE OF MASTER SWITCH PANEL ASSEMBLY

TASK INDEX

<u>Task</u>	<u>Page</u>	<u>Task</u>	<u>Page</u>
Replace Master Switch Assembly	9-13	Replace Master Switch . Panel Assembly (M577A2 and M1068 Only)	9-22 ■
Replace Master Switch Panel Assembly (Late Slave Receptacle) (All Except M577A2 and M1068)	9-16	Replace Master Switch to Distribution Box Wire Assembly (Circuit 49 Lead) (All Except M577A2 and M1068)	9-26 ■
Replace Master Switch Panel Assembly (Early Slave Receptacle) (All Except M577A2)	9-19		

REPLACE MASTER SWITCH ASSEMBLY

DESCRIPTION

This task covers: Remove (page 9-13). Install (page 9-14).

INITIAL SETUP

Tools:

General Mechanics Tool Kit (Item 30, App D)

Materials/Parts:

- Lockwasher (3)
- Self-locking nut (2)
- Self-locking nut (8)

References:

See your -10

Equipment Conditions:

- Engine stopped/shutdown (see your -10)
- Carrier blocked (see your -10)
- Battery ground lead disconnected (page 13-2)

Personnel Required:

Unit Mechanic

REMOVE

1. Disconnect circuit 37 lead (1) from connector (2).
2. Remove eight locknuts (3), washers (4), screws (5), and master switch panel (6) from distribution box (7). Discard locknuts.

NOTE
On M577A2 and M1068 carriers do step 3, then go to step 5. On all other carriers, after step 2, go to step 4.

3. Remove nut (8), lockwasher (9), and circuit 49 lead (10) from master switch terminal (11). Discard lockwasher.

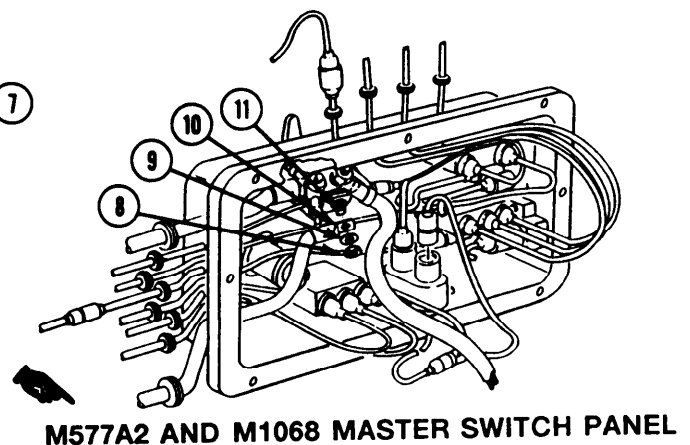
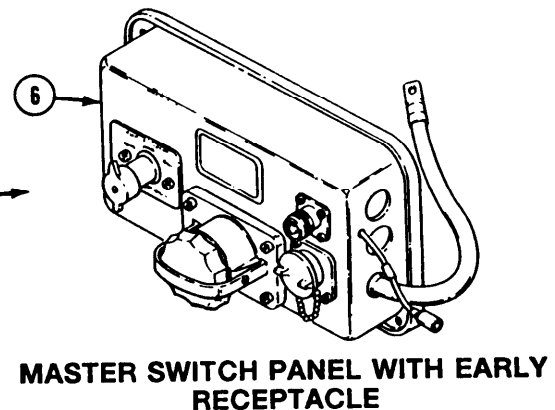
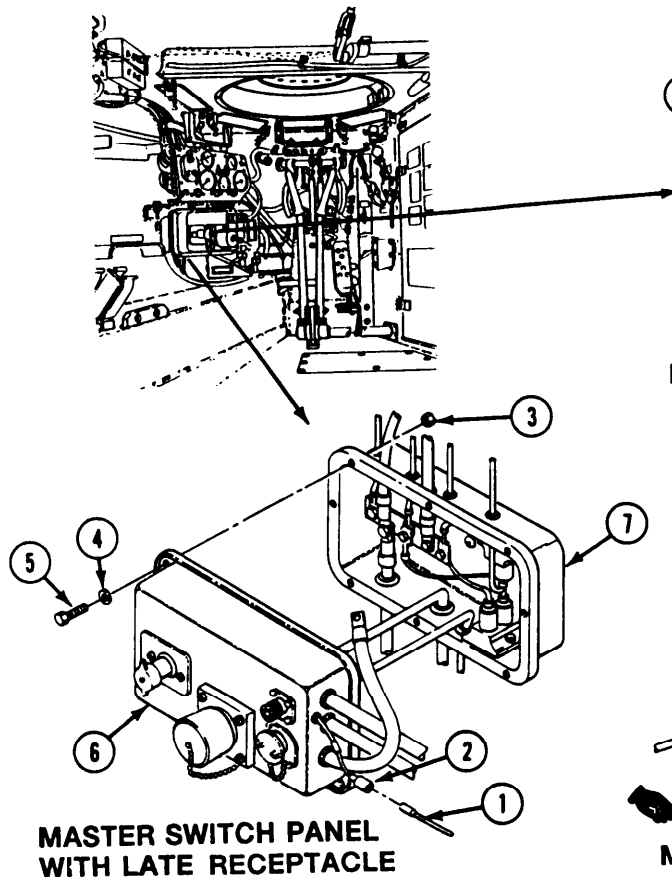

GO TO NEXT PAGE

- Remove nut (1), lockwasher (2), circuit 60 lead (8), and circuit 49 lead (4) from master switch terminal (5). Discard lockwasher

NOTE

M741A1 carriers and carriers that have 100 Amp Generators do not have circuit 2A.

- Remove nut (6), lockwasher (7), circuit 2A lead (8), and conductor bus (9) with attached leads from master switch terminal (10). Discard lockwasher

- Remove screw (11), washer (12), and knob (13) from master switch (14).

- Remove two locknuts (15), screws (16), master switch (14), and nameplate (17) from master switch panel (18). Discard locknuts.

INSTALL

- Align master switch (14) and nameplate (17) on master switch panel (18). Secure with two screws (16) and new locknuts (15).

NOTE

Make sure nameplate is not installed upside down.

- Place knob (13) on master switch (14). Secure with washer (12) and screw (11).

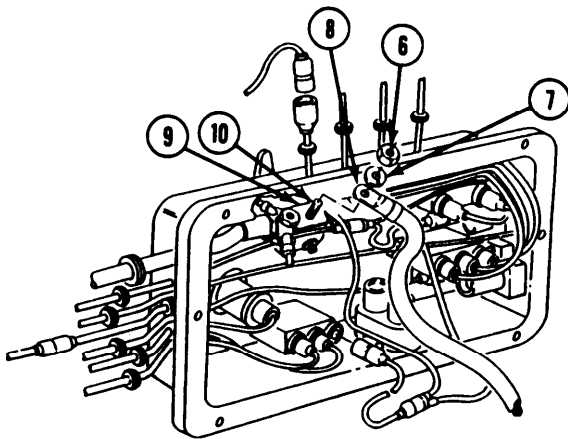
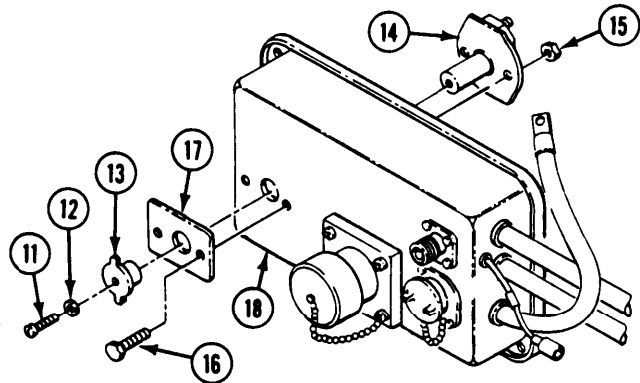
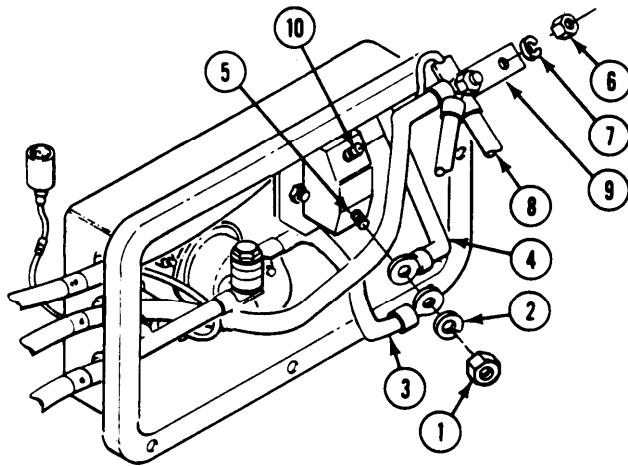

M577A2 MASTER SWITCH PANEL

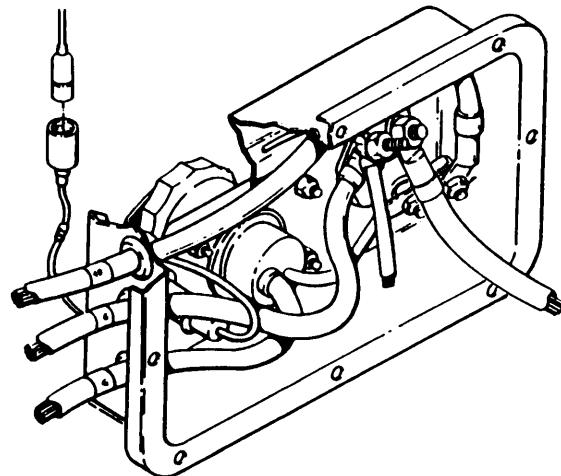

MASTER SWITCH PANEL WITH EARLY RECEPTACLE

NOTE

M741A1 carriers and carriers that have 100 Amp Generators do not have Circuit 2A.

10. Install conductor bus (1) with attached leads, and circuit 2A lead (2) on terminal (3). Secure with new lockwasher (4) and nut (5).

13. Install master switch panel (11) on distribution box (12). Secure with eight screws (13), washers (14), and new locknuts (15).

14. Connect circuit 37 lead (16) to connector (17).

NOTE

On M577A2 and M1068 earners do step 11, then go to step 13. On all other earners, after step 10, go to step 12.

11. Install circuit 49 lead (6) on master switch terminal (7). Secure with new lockwasher (8) and nut (9).

12. Install circuit 49 lead (6) and circuit 50 lead (10) on terminal (7). Secure with new lockwasher (8) and nut (9).

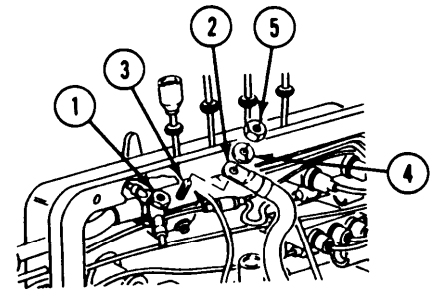
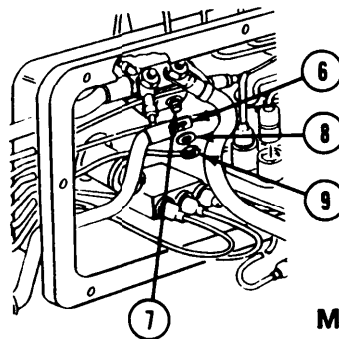
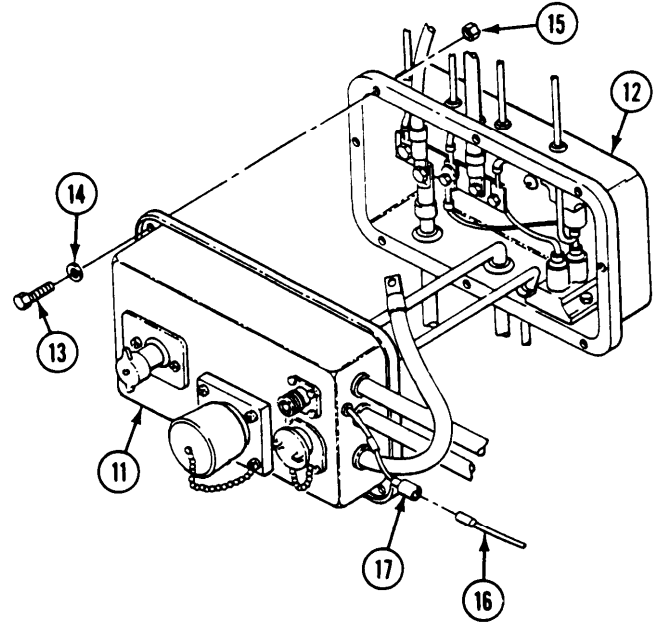
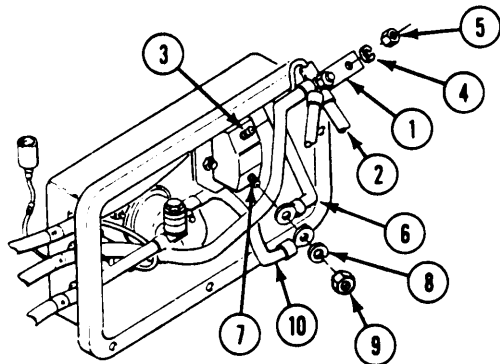

**M577A2 AND M1068
MASTER SWITCH PANEL**

FOLLOW-THROUGH STEPS

1. Connect battery ground lead (page 13-2).
2. Turn MASTER SWITCH ON (see your -10).
3. MASTER SWITCH light should come on (see your -10).
4. Turn MASTER SWITCH OFF (see your -10).

END OF TASK

REPLACE MASTER SWITCH PANEL ASSEMBLY (LATE SLAVE RECEPTACLE) (ALL EXCEPT M577A2 - M1068)

DESCRIPTION

This task covers: Remove (page 9-16). Install (page 9-17).

INITIAL SETUP

Tools:

General Mechanics Tool Kit (Item 30, App D)

Materials/Parts:

Grommet (3)
 Lockwasher (3)
 Self-locking nut
 Self-locking nut (8)

Personnel Required

Unit Mechanic

References:

see your -10

Equipment Conditions:

Engine stopped/shutdown (see your -10)
 Carrier blocked (see your -10)
 Battery ground lead disconnected (page 13-2)
 Infrared power supply cable disconnected from master switch panel (page 12-134)

REMOVE

1. Disconnect circuit 37 lead (1) from connector (2).
2. Remove eight locknuts (3), washers (4), screws (5), and master switch panel (6) from distribution box (7). Discard locknuts.

3. Remove screw (8), lockwasher (9), and ground lead (10) from negative post (11) of auxiliary power receptacle (12). Remove ground lead and grommet (13) from master switch panel (6). Discard lockwasher and grommet.

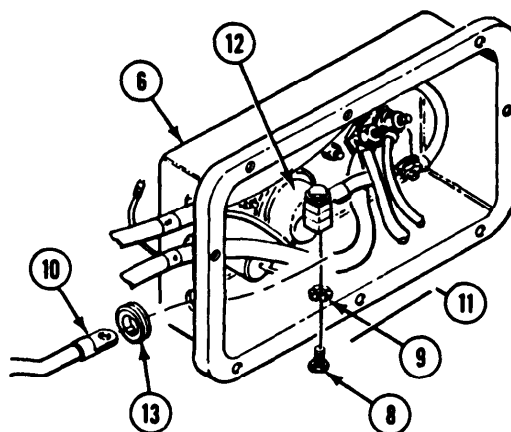
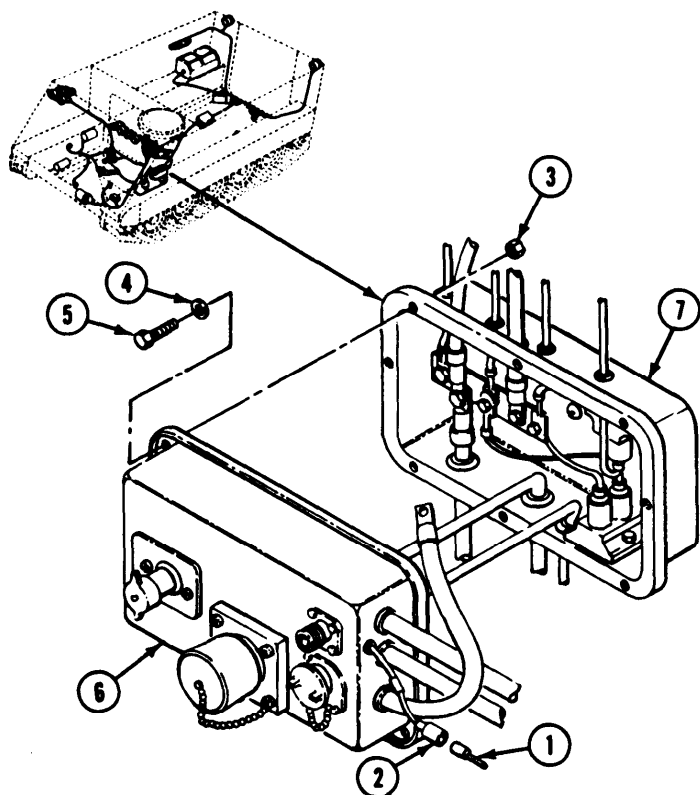

- Remove screw (1), locknut (2), leads 400 and 2 (3 and 4), and circuit 6 lead (5) from conductor bus (7). Remove circuit 6 lead and grommet (8) from master switch panel (9). Discard locknut and grommet.

NOTE

M741 and all 100 amp generator systems do not have circuit 2A lead (6).

- Remove nut (10), lockwasher (11), and circuit 2A lead (6) from post (12) on master switch panel (9). Discard lockwasher.
- Remove screw (13), lockwasher (14), and circuit 49 lead (15) from bus bar (16) of distribution box (17). Remove circuit 49 lead (15) and grommet (18) from distribution box (17). Discard lockwasher and grommet.
- Remove master switch panel (19) from carrier.

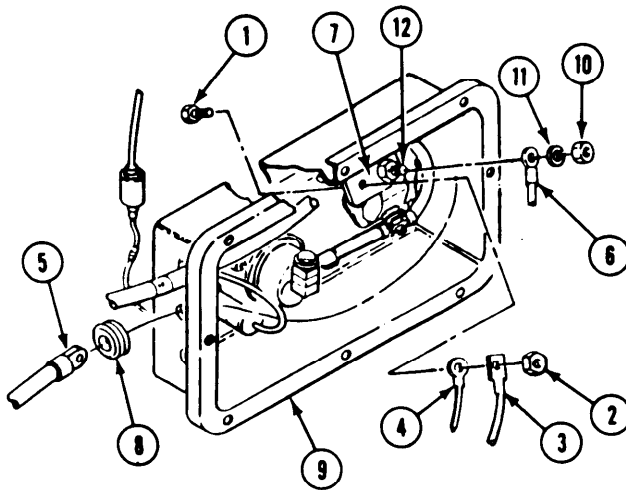

INSTALL

- Install new grommet (18) on circuit 49 lead (15). Route lead into distribution box (17) and secure grommet.
- Install circuit 49 lead (15) on bus bar (16). Secure with new lockwasher (14) and screw (13).
- Install new grommet (8) on circuit 6 lead (5). Route lead into master switch panel (9), and secure grommet.
- Install circuit 6 lead (5), leads 2 and 400 (3 and 4) on conductor bus (7). Secure with screw (1) and new locknut (2),

NOTE

M741 and all 100 amp generator systems do not have circuit 2A lead.

- Install circuit 2A lead (6) on master switch post (12). Secure with new lockwasher (11) and nut (10).

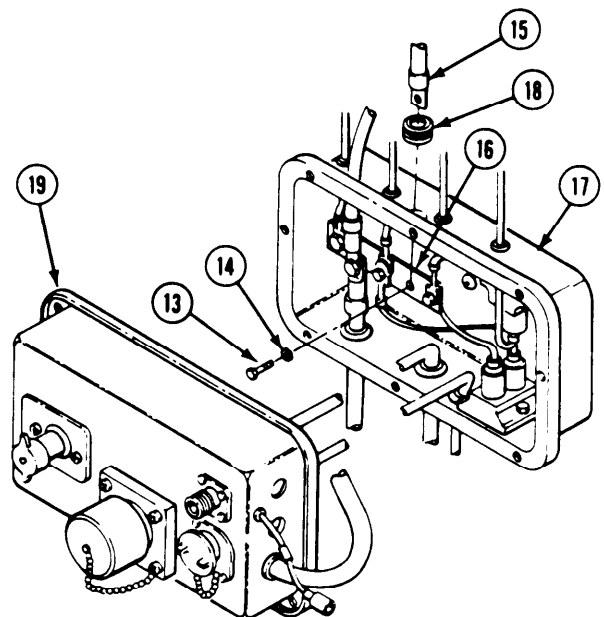

GO TO NEXT PAGE

13. Install new grommet (1) on ground lead (2). Route lead into master switch panel (3), and secure grommet.
14. Install ground lead (2) on negative post (4) of auxiliary power receptacle (5). Secure with screw (6) and new lockwasher (7).

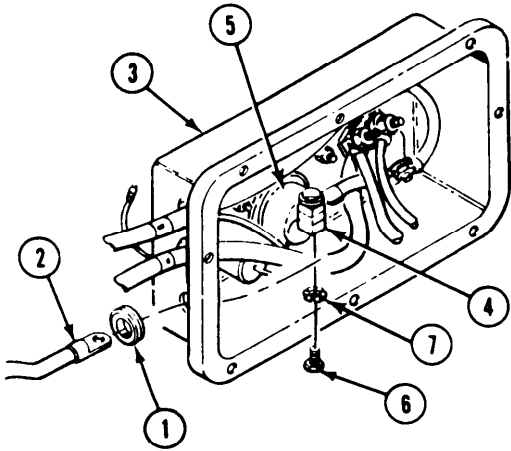

15. Install master switch panel (3) on distribution box (8). Secure with eight screws (9), washers (10), and new locknuts (11).
16. Connect circuit 37 lead (12) to connector (13).

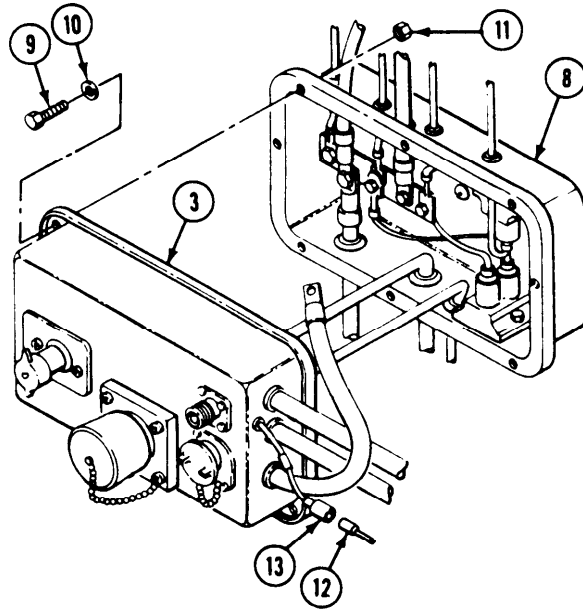

FOLLOW-THROUGH STEPS

1. Connect infrared power supply cable (page 12-134).
2. Connect battery ground lead (page 13-2).
3. Turn master switch on. Check for proper operation (see your -10).
4. Turn master switch off (see your -10).

END OF TASK

REPLACE MASTER SWITCH PANEL ASSEMBLY (EARLY SLAVE RECEPTACLE) (ALL EXCEPT M577A2)

DESCRIPTION

This task covers: Remove (page 9-19). Install (page 9-20).

INITIAL SETUP

Tools:

General Mechanics Tool Kit (Item 30, App D)

References:

see your -10

Materials/Parts:

Grommet (2)
Lockwasher (3)
Self-locking nut (2)
Self-locking nut (8)

Equipment Conditions:

Engine stopped/shutdown (see your -10)
Carrier blocked (see your -10)
Battery ground lead disconnected (page 13-2)
Infrared power supply cable disconnected from master switch panel (page 12-134)

Personnel Required:

Unit Mechanic

REMOVE

1. Disconnect circuit 37 lead (1) from circuit 38 lead (2).
2. Remove eight locknuts (3), washers (4), and screws (5). Separate master switch panel assembly (6) from distribution box (7). Discard locknuts.
3. Remove screw (8), locknut (9), washer (10), and ground lead (11) from instrument panel strut (12). Discard locknut.
4. Remove circuits 49 and 6 leads (13 and 14) and two grommets (15) from master switch panel assembly (6). Discard grommets.

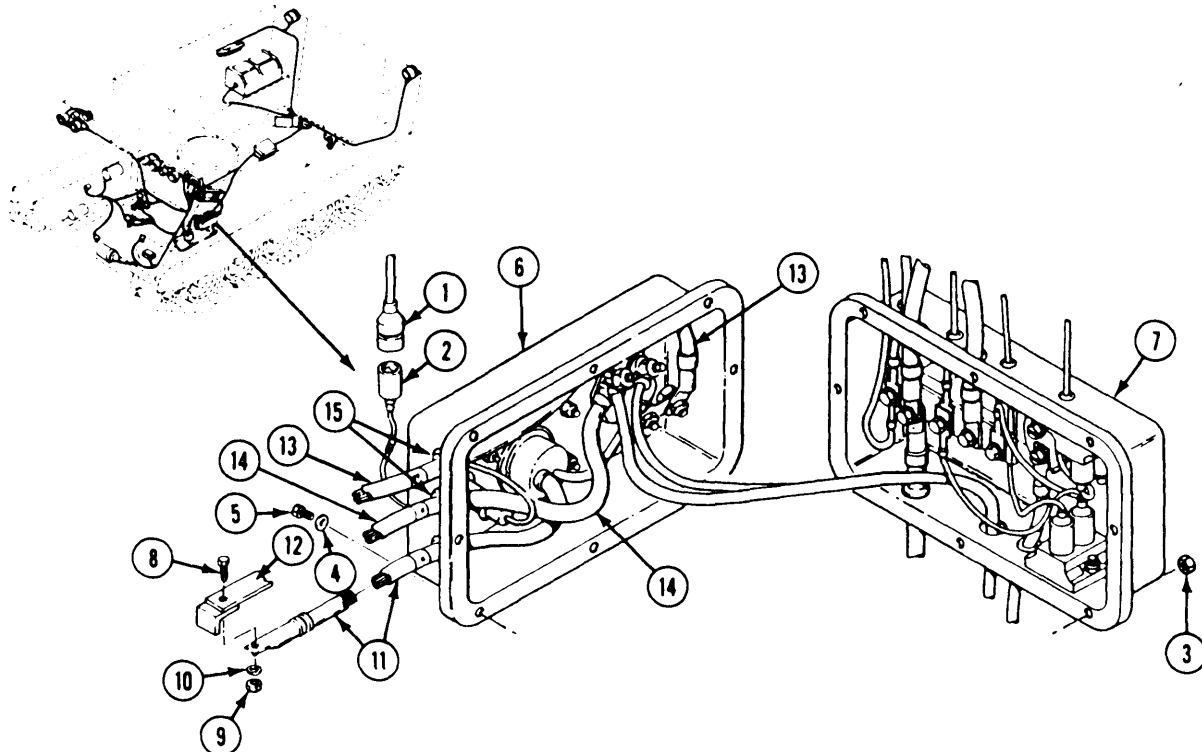

GO TO NEXT PAGE

5. Remove nut (1), screw (2), two lockwashers (3), and circuit 49 lead (4) from auxiliary power receptacle lead (5). Discard lockwashers.
6. Remove locknut (6), screw (7), and circuits 6, 2, and 400 leads (8, 9, and 10) from bus bar (11). Discard locknut.

NOTE

All carriers with 200 amp generator (except M741A1) do step 7.

7. Remove nut (12), lockwasher (13), and circuit 2A lead (14) from master switch terminal (15). Discard lockwasher.
8. Remove master switch panel (16) from carrier.

INSTALL

9. Install two new grommets (17) in master switch panel assembly (16).
10. Install circuit 49 and 6 leads (8 and 4) through two grommets (17) into master switch panel (16).

NOTE

All carriers with 200 amp generator (except M741A1) do step 11.

11. Install circuit 2A lead (14) on master switch terminal (15). Secure with new lockwasher (13) and nut (12).

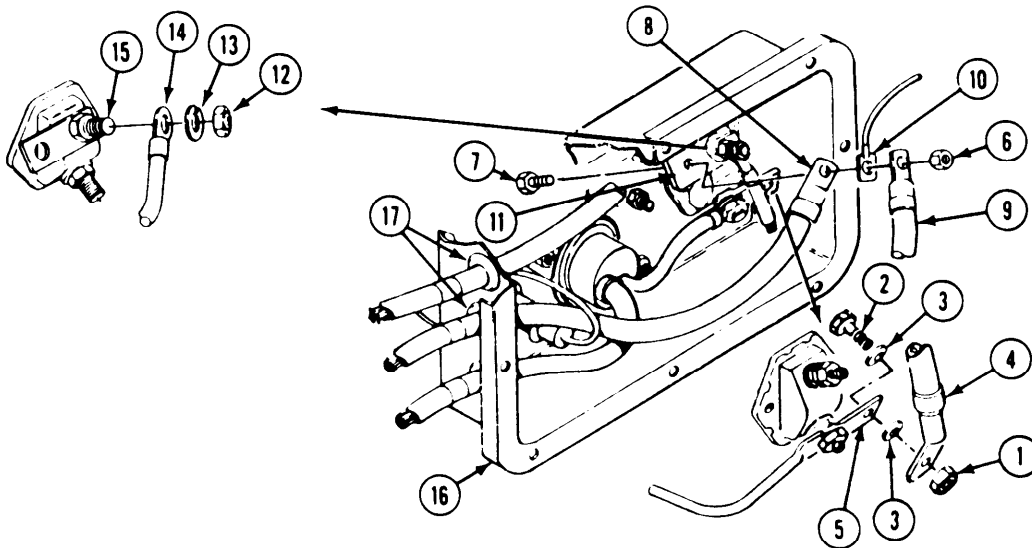

12. Install circuits 6, 2, and 400 leads (8, 9, and 10) on bus bar (11). Secure with screw (7) and new locknut (6).
13. Install circuit 49 lead (4) on auxiliary power receptacle lead (5). Secure with screw (2), nut (1), and two new lockwashers (3).

NOTE

Check gasket on master switch panel flange for cracks or other damage. Replace gasket if damaged.

14. Install master switch panel (1) on distribution box (2). Secure with eight screws (3), washers (4), and nuts (5).

15. Install ground lead (6) on instrument panel strut (7). Secure with screw (8), nut (9), and washer (10).
16. Connect circuit 37 lead (11) to circuit 38 lead (12).

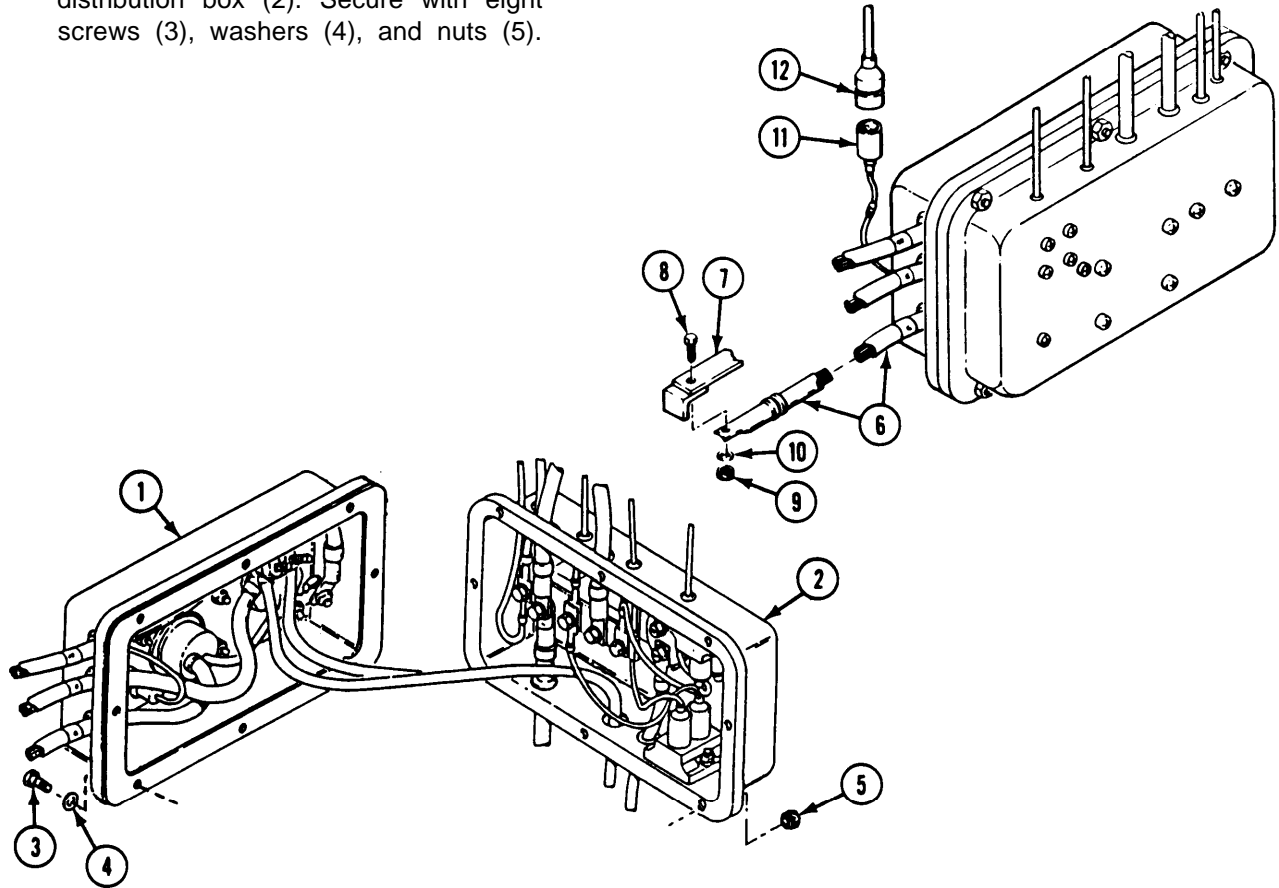

FOLLOW-THROUGH STEPS

1. connect battery ground leads (page 13-2).
 2. Connect infrared power supply cable (page 12-134).
 3. Start engine (see your -10). Check that master switch panel assembly works properly.
 4. Stop/shutdown engine (see your -10).
-

END OF TASK

REPLACE MASTER SWITCH PANEL ASSEMBLY (M577A2 AND M1068 ONLY)

DESCRIPTION

This task covers: Remove (page 9-22). Install (page 9-24).

INITIAL SETUP

Tools:

General Mechanics Tool Kit (Item 30, App D)

References:

See your -10

Materials/Parts:

Grommet (11)
Lockwasher
Self-locking nut (8)

Equipment Conditions:

Engine stopped/shutdown (see your -10)
Carrier blocked (see your -10)
Battery ground lead disconnected (page 13-2)

Personnel Required:

Unit Mechanic

REMOVE

NOTE

Step 6 is for 200 amp generator system only. All other steps are common.

1. Remove eight locknuts (1), washers (2), and screws (3). Separate master switch panel assembly (4) from distribution box (5). Discard locknuts.
2. Disconnect wiring harness (6) leads (7, 8, and 9) from three circuit breakers (10, 11, and 12).

3. Remove nut (16), washer (17), and circuit 49 lead (13) from bottom terminal on master switch (14).
4. Remove circuit 49 lead (13) and grommet (15) from master switch panel assembly (4). Discard grommet.

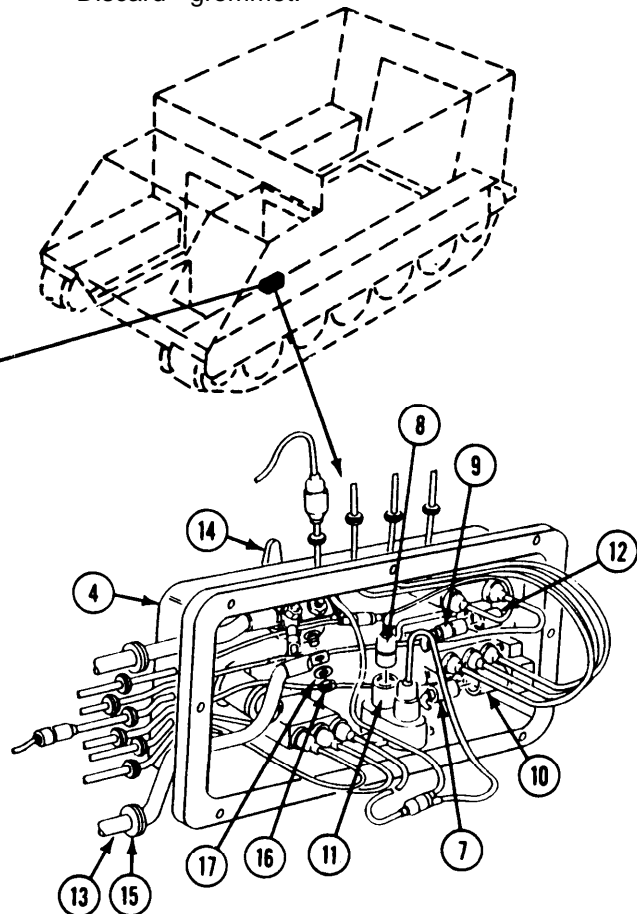
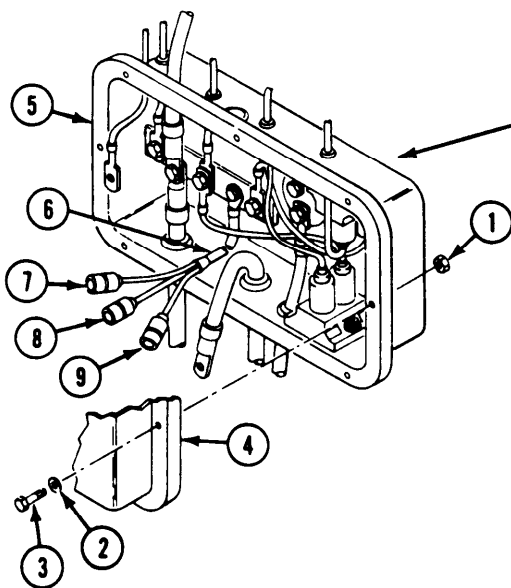

5. Remove nut (1), screw (2), and circuits 400. 2, and 6 leads (3, 4, and 5) from bus bar (6).
6. For 200 amp generator system, remove nut (7), lockwasher (8), and circuit 2A lead (9) from top terminal on master switch (10). Discard lockwasher.
7. Remove circuit 6 lead (5) and grommet (11) from master switch panel (12). Discard grommet.
8. Disconnect wiring harness (14) from circuit 38E (15). Disconnect circuit 10 lead (16) from circuit breaker (17). Disconnect circuit 10 lead (18) from dome light switch (13).
9. Remove wiring harness (14) and grommet (19) from master switch panel (12). Discard grommet.
10. Disconnect wiring harness (20) from blower switch (21) and circuit 37B on circuit breaker (22).
11. Disconnect circuit 59 lead (23) from blower switch (21).
12. Remove circuit 59 lead (23), wiring harness (20), and two grommets (24) from master switch panel assembly (25). Discard grommets.
13. Disconnect utility outlet lead (26) from circuit 37 lead (27).
14. Disconnect circuit 37A lead (28) from circuit 37A lead on circuit breaker (29).

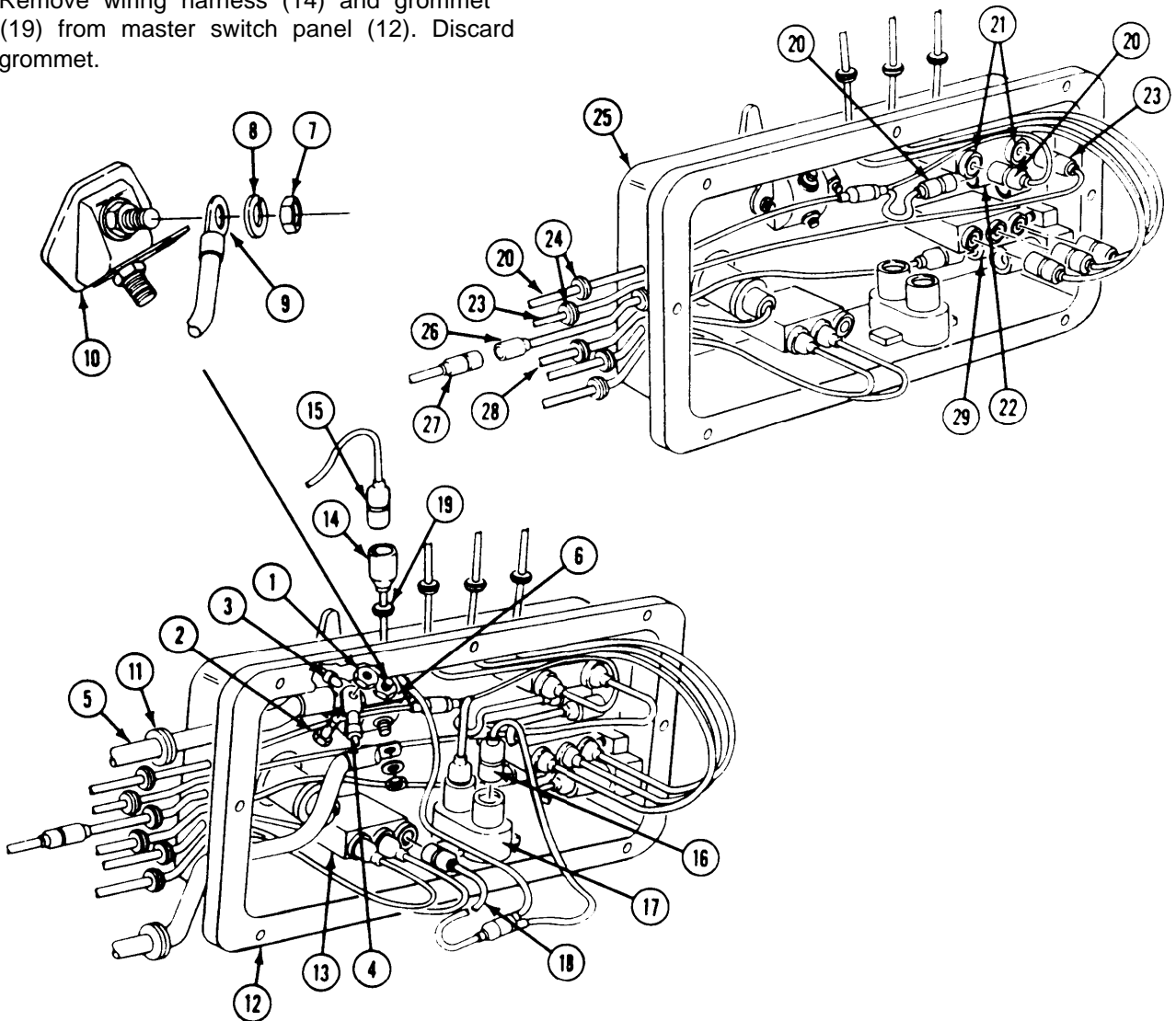

GO TO NEXT PAGE

15. Disconnect circuits 38A and 38 leads (9 and 10) from dome light switch (12).
16. Remove circuits 37A, 38, 38A leads (8, 10, and 9) and three grommets (7) from master switch panel (1). Discard grommets.
17. Disconnect circuits 28, 29, and 30 leads (3, 4, and 5) from fuel selector switch (6).
18. Remove circuits 28, 29, 30 leads (3, 4, and 5) and three grommets (2) from master switch panel (1). Discard grommets.
19. Remove master switch panel assembly (1) from carrier.

INSTALL

20. Install three new grommets (92) and circuits 28, 29, and 30 leads (3, 4, and 5) in master switch panel (1).
21. Connect circuits 28, 29, and 30 leads (3, 4, and 5) to fuel selector switch (6).
22. Install three new grommets (7) and circuits 37A, and 38, and 38A leads (8, 9, and 10) in master switch panel assembly (1).
23. Connect circuit 37A lead (8) to circuit breaker (1).
24. Connect circuits 38 and 38A leads (9 and 10) to dome light switch (12).
25. Connect utility outlet lead (13) to circuit 37 lead (14).
26. Install two new grommets (15), wiring harness (16), and circuit 59 lead (17) in master switch panel (1).
27. Connect wiring harness 916) to blower switch (18) and to circuit 37B lead on circuit breaker (19).
28. Connect circuit 59 lead (17) to blower switch (18).

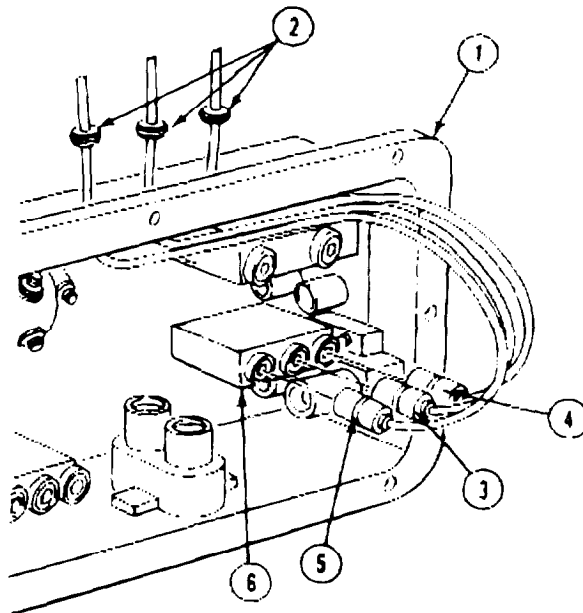
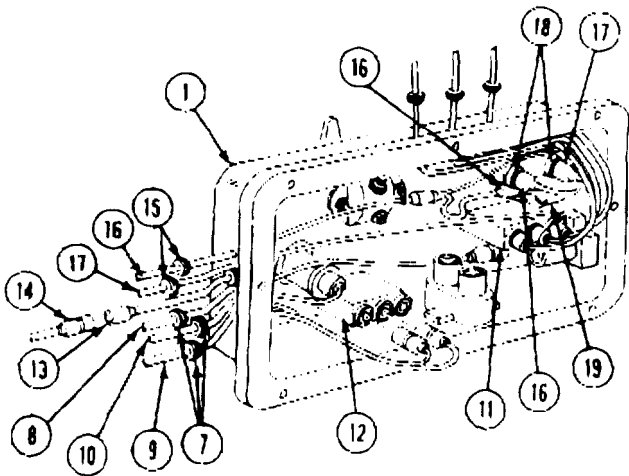

29. Install a new grommet (1) and wiring harness (2) in master switch panel (3).
30. Connect wiring harness (2) to circuit 38E lead (4). Connect circuit 10 lead (5) on circuit breaker (6). Connect circuit 10 lead (7) on dome light switch (8).
31. Install a new grommet (9) and circuit 6 lead (10) in master switch panel (3).

NOTE

Step 32 is for 200 amp generator only. All other steps are common.

32. For 200 amp generator system, install circuit 2A lead (11) on top terminal of master switch (12). Secure with new lockwasher (13) and nut (14).
33. Install circuits 6, 2, and 400 leads (10, 16, and 16) on bus bar (17). Secure with screw (18) and nut (19).

34. Install new grommet (20) and circuit 49 lead (21) in master switch panel assembly (3).
35. Install circuit 49 lead (21) on bottom terminal of master switch (12). Secure with washer (22) and nut (23).
36. Connect wiring harness (24) leads (25, 26, and 27) to three circuit breakers (28, 29, and 30).
37. Replace gasket between master switch panel and distribution box, if damaged (page 12-25).
38. Install master switch panel (31) on distribution box (32). Secure with eight screws (33), washers (34), and new locknuts (35).

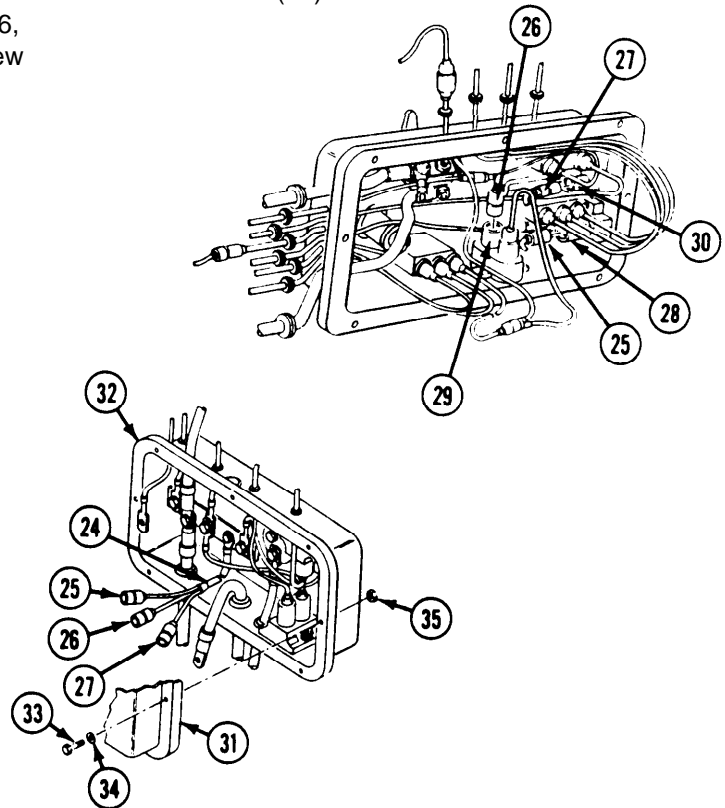
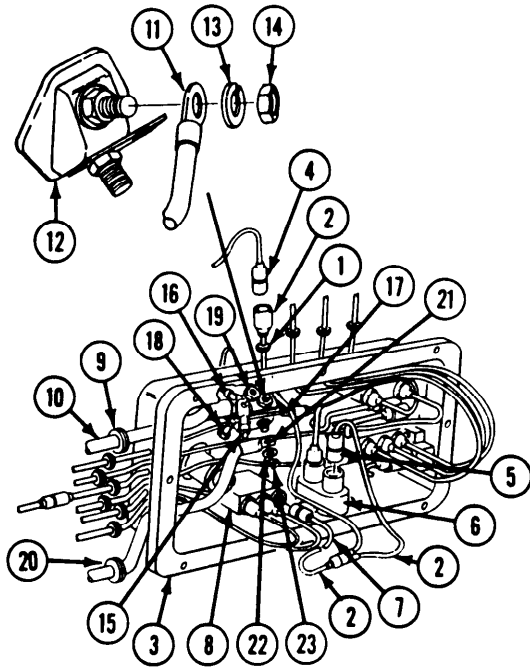

FOLLOW-THROUGH STEPS

1. Connect battery ground lead (page 13-2).
2. Start engine (see your -10). Check that master switch panel assembly is operable.
3. Stop/shutdown engine (see your -10).

REPLACE MASTER SWITCH TO DISTRIBUTION BOX WIRE ASSEMBLY (CIRCUIT 49 LEAD) (ALL EXCEPT M577A2 AND M1068)

DESCRIPTION

This task covers: Remove (page 9-26). Clean, Inspect, and Repair (page 9-27).
Install (page 9-27).

INITIAL SETUP

Tools:

General Mechanics Tool Kit (Item 30, App D)
Multimeter (Item 43, App D)

Materials/Parts:

Grommet (2)
Self-locking nut (2)
Self-locking nut (8)

Personnel Required:

Unit Mechanic

References:

see your -10

Equipment Conditions:

Engine Stopped./Shutdown (see your -10)
Carrier blocked (see your -10)
Battery ground lead disconnected (page 13-2)

REMOVE

1. Remove eight locknuts (1), washers (2), screws (3), and master switch panel (4) from distribution box (5). Discard locknuts.
2. Early slave receptacle only: remove locknut (6), two washers (7), screw (8), and circuit 49 lead (9) from circuit 50 lead terminal lug (10). Discard locknut.
3. Late slave receptacle only: remove locknut (11), circuit 50 lead (12), and circuit 49 lead (13) from master switch terminal (14). Discard locknut.
4. Remove screw (15), washer (16), and circuit 49 lead (9) from distribution box bus bar (17).

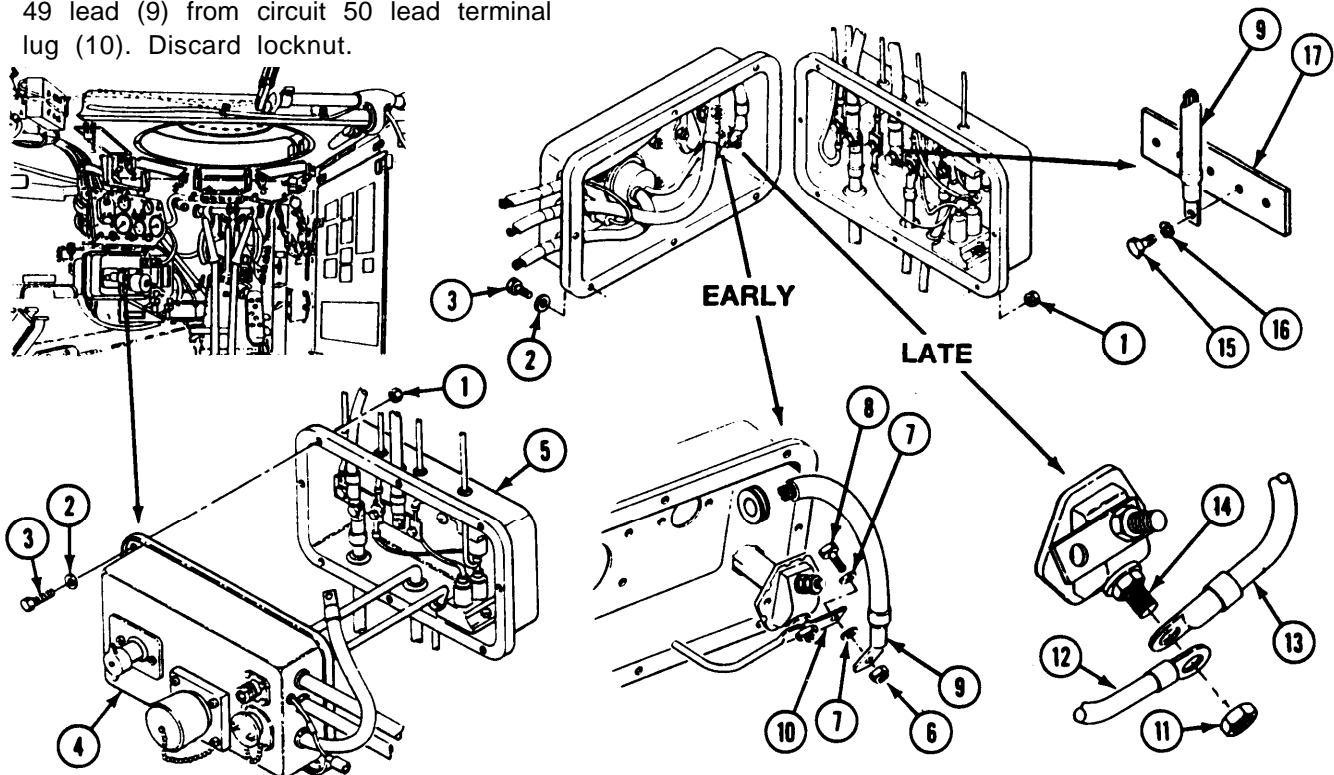

- Remove circuit 49 lead (1) with two grommets (2) from master switch panel (3) and distribution box (4). Discard grommets.

CLEAN, INSPECT, AND REPAIR

- Check circuit 49 lead for continuity. Use multimeter. Replace bad lead.

INSTALL

- Install two new grommets (2) on circuit 49 lead (1).
- Route circuit 49 lead (1) through distribution box (4) and master switch panel (3). Install grommets (2) in box and panel.
- Install circuit 49 lead (1) on bus bar (5) of distribution box (4). Secure with washer (6) and screw (7).

- Early slave receptacle only: install circuit 49 lead (1) on circuit 50 lead terminal lug (8). Secure with two washers (9), screw (10) and new locknut (11).

- Late slave receptacle only: install circuit 50 lead (12), circuit 49 lead (13), and new locknut (14) on master switch terminal (15).

- Install master switch panel (3) on distribution box (4). Secure with eight screws (16), washers (17), and new locknuts (18).

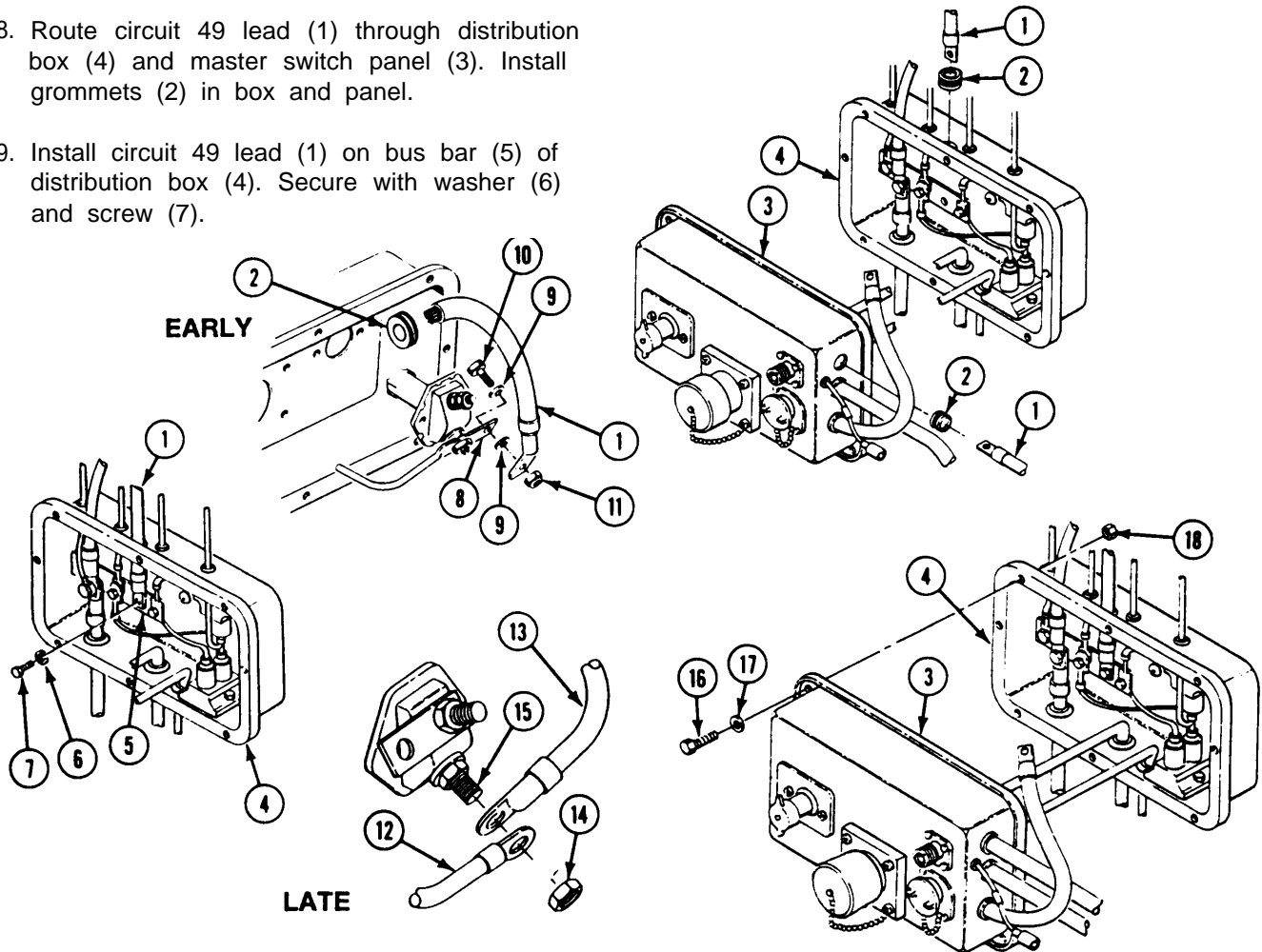

FOLLOW-THROUGH STEPS

- Connect battery ground lead (page 13-2).
- Turn MASTER SWITCH ON (See your -10).
- Check that circuit 49 lead is operational. MASTER SWITCH light should come on.
- Turn MASTER SWITCH OFF (see your -10).

END OF TASK

**Section III. MAINTENANCE OF GENERATOR, REGULATOR, AND
CIRCUIT 49 LEAD WIRE ASSEMBLIES**

TASK INDEX

<u>Task</u>	<u>Page</u>	<u>Task</u>	<u>Page</u>
Replace Generator Drive Belts (100 Amp Gen Only)	9-29	Replace Generator-Regulator Circuit Breaker (100 Amp Gen Only)	9-42
Replace Generator and Adjustment Linkage (100 Amp Gen Only)	9-31	Replace Generator Field Switch	9-44
Replace Generator and Adjustment Linkage (200 Amp Gen Only)	9-34	Replace Fuel Filter Mounting Bracket (M577A2 and M1068 With 200 Amp Gen Only)	9-45
Adjust Voltage Regulator (100/200 Amp Generator)	9-38	Replace Generator Drive Belts (200 Amp Gen Only)	9-47
Replace Regulator Assembly (100/200 Amp Generator) I*.*..***.*.	9-40	Replace Master Switch to Distribution Box Wire Assembly (Circuit 49 Lead) (M577A2 and M1068 Only)	9-49

REPLACE GENERATOR DRIVE BELTS (100 AMP GEN ONLY)

DESCRIPTION

This task covers: Remove (page 9-29). Clean, Inspect, and Replace (page 9-30).
Install (page 9-30).

INITIAL SETUP

Tools:

General Mechanics Tool Kit (Item 30 App D)

Personnel Required:

Unit Mechanic

References:

see your -lo

Equipment Conditions:

Engine stopped/shutdown (see your -10)
Carrier blocked (see your -10)
Power plant rear access panels removed (page 24-27)
Engine compartment cover support removed (all except M106A2 and M125A2) (page 24-27)

REMOVE

1, Loosen locknut (1) on rod end (2).

2. Turn turnbuckle (3) to loosen two drive belts (4).

3. Remove two drive belts (4) from generator pulley (5) and drive pulley (6).

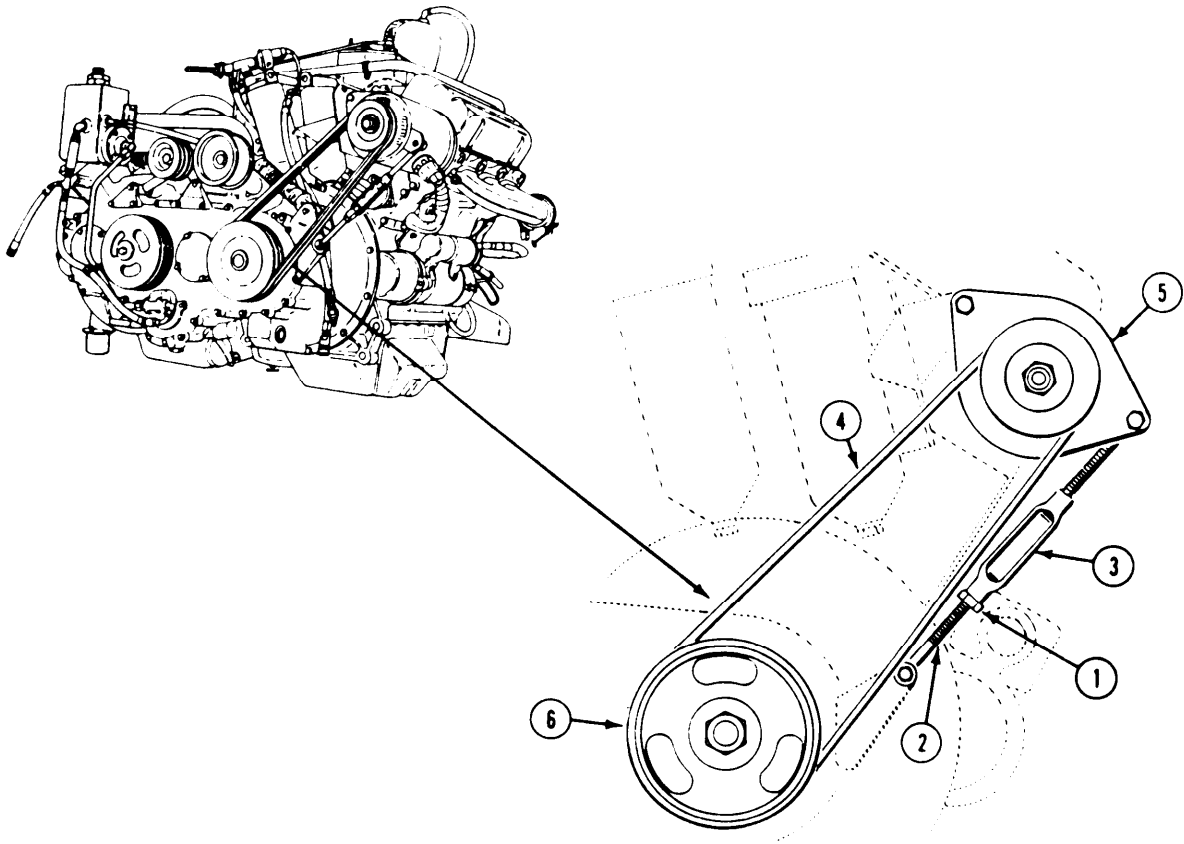

GO TO NEXT PAGE

CLEAN, INSPECT, AND REPLACE

4. Inspect drive belts. If either belt is worn or damaged, discard both old belts and install new ones.

INSTALL

5. Install two drive belts (1) on drive pulley (2) and generator pulley (3).

NOTE

When replacing drive belts, replace in matched sets only.

6. Turn turnbuckle (4) and tighten belt until belt deflection at midspan is 1/2 to 5/8 inch (13 to 16 mm) when 25 pounds (11 kg) of force is applied.
7. Tighten locknut (5) on rod end (6).

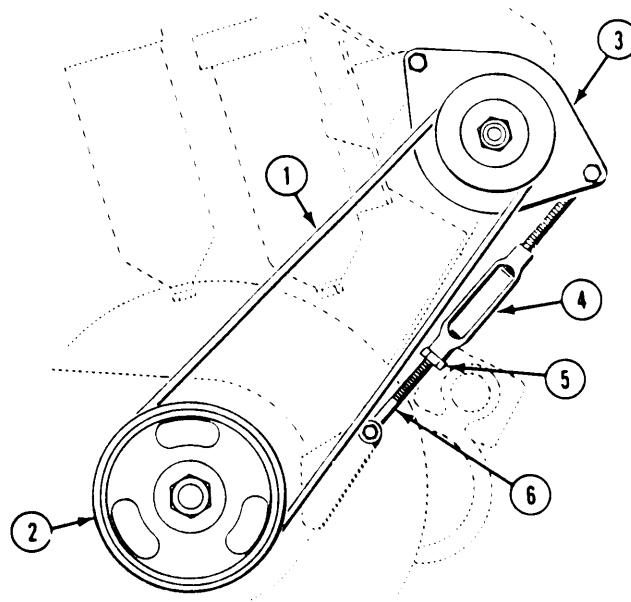

FOLLOW-THROUGH STEPS



WARNING

Wearing loose clothing around moving parts can allow personnel to get caught and could result in injury or death. Tuck in loose clothing.

1. Start engine (see your -10). Make sure drive belts are installed properly.

2. Stop/shutdown engine (see your -10).
3. Install engine compartment cover support (page 24-27).
4. Install power plant rear access panels (page 24-27).

END OF TASK

REPLACE GENERATOR AND ADJUSTMENT LINKAGE (100 AMP GENERATOR ONLY)

DESCRIPTION

This task covers: Remove (page 9-3 1). Install (page 9-32).

INITIAL SETUP

Tools:

General Mechanics Tool Kit (Item 30, App D)
Socket Wrench Set (Item 89, App D)
Torque Wrench (Item 94, App D)

Materials/Parts:

Antiseize compound (Item 4, App C)
Key washer (2)
Lockwasher
Self-locking nut (6)
Self-locking nut (2)

Personnel Required:

Unit Mechanic

References:

see your -lo

Equipment Conditions:

Engine stopped/shutdown (see your -10)
Carrier blocked (see your -10)
Battery ground lead disconnected (page 13-2)
Power plant rear access panels and support removed (page 24-27)
Generator drive belts removed (page 9-29)

REMOVE

1. Disconnect cable (1) from generator (2).
2. Remove locknut (3), screw (4), rod end (5), and spacer (6) from generator (2). Discard locknut.
3. Remove locknut (7), screw (8), rod end (9), and spacer (10) from bracket (11). Discard locknut.
4. Remove two rod ends (5 and 9) from turnbuckle (12). Remove jam nut (13) from rod end (9).
5. Remove three screws (14), two key washers (15), lockwasher (16), flat washer (17), and bracket (11) from transfer gearcase. Discard key washers and lockwasher.

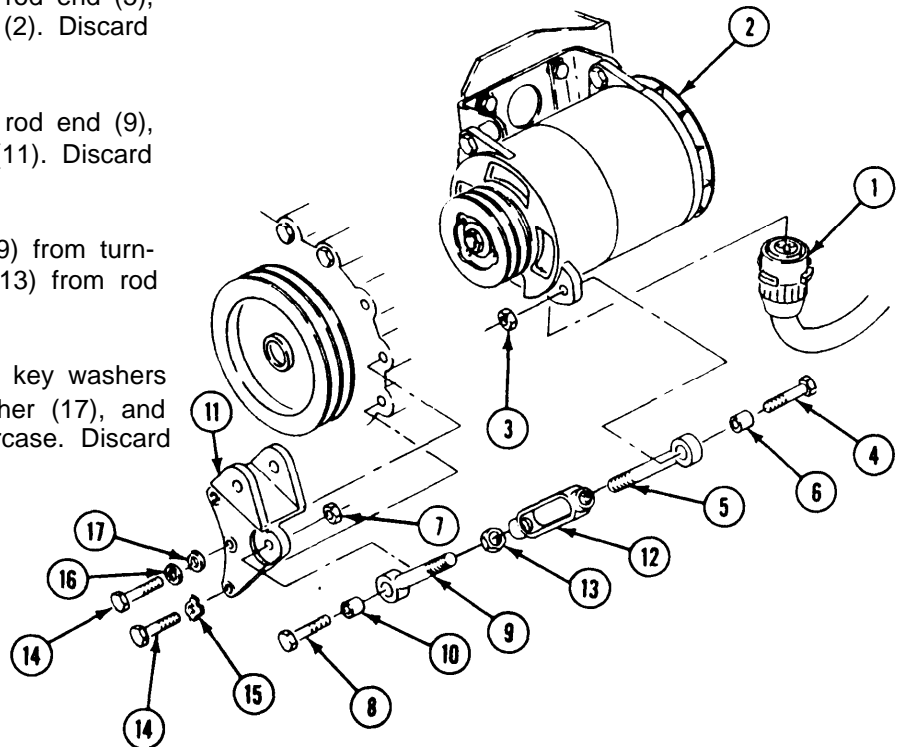

GO TO NEXT PAGE

6. Support generator (1). Remove two locknuts (2), washers (3), Screw (4), screw (5), and generator (1) from mounting bracket (6). Discard locknuts.
7. Remove four locknuts (7), screws (8), two straps (9), and bracket (6) from engine. Discard locknuts.

NOTE

If replacing generator, do steps 8 through 10.

- s. Remove three screws (10) and washers (11) that secure pulley (12) and bushing (13) to generator shaft (14).
9. Use three screws (10) to separate pulley (12) and bushing (13). (Install three screws in three threaded holes of pulley. Tighten screws until you are able to separate pulley from bushing.)
10. Remove pulley (12) and bushing (13) from generator shaft (14). Remove key (15) from generator shaft.

INSTALL

NOTE

If installing new generator, begin with step 11, but remove nut and washer from generator shaft before installing pulley. Nut and washer are not used. If not installing new generator go to step 13.

11. Install key (15) on generator shaft (14). Install bushing (13) and pulley (12) on generator shaft.
12. Secure bushing (13) and pulley (12) to generator shaft (14) with three washers (11) and screws (10). Alternately tighten screws. Torque screws to 73-79 lb-in (8.2-8.9 N-m). Use torque wrench and socket wrench set.
13. Place bracket (6) on engine. Secure with two straps (9), four screws (8), and new locknuts (7). Do not tighten.
14. Install generator (1) on bracket (6). Secure with screw (5), screw (4), two washers (3), and new locknuts (2).

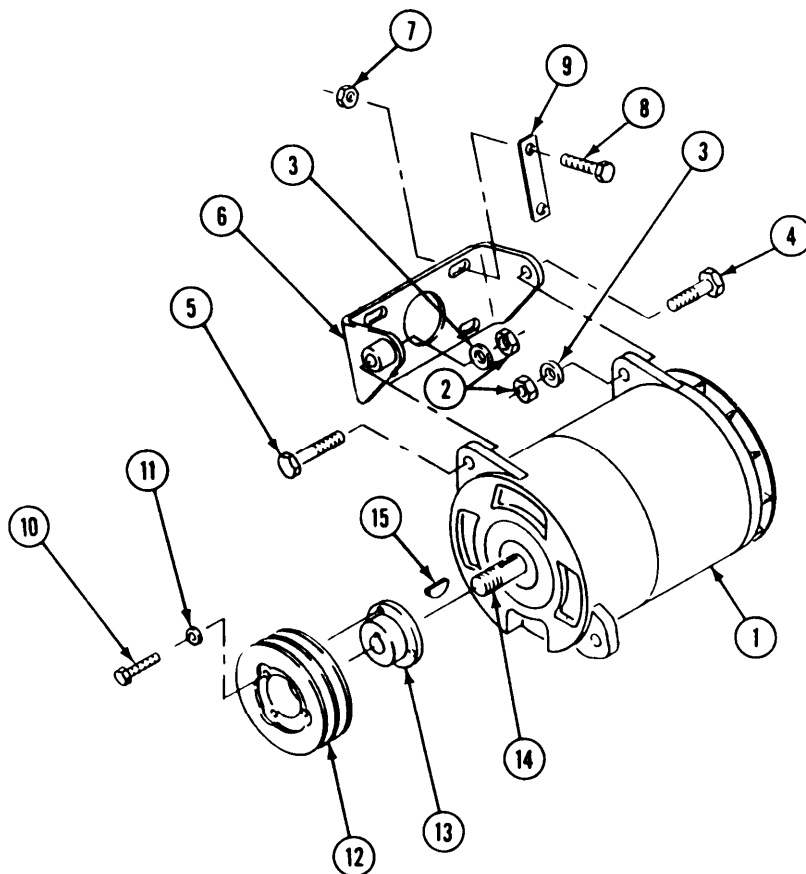

15. Coat threads of three screws (1) with anti-seize compound.
16. Install bracket (2) on transfer gearcase. Secure with two new key washers (3), flat washer (4), new lockwasher (5), and three screws (1). Bend tabs on key washers (3).
17. Screw jam nut (6) on rod end (7). Install rod ends (7 and 8) in turnbuckle (9).
18. To obtain correct alignment, adjust the position of the generator mounting bracket (10) before you tighten the screws (11) in the slotted holes. Align pulley (12), on generator (13), with drive pulley (14), on the transfer gearcase, to within 1/8 inch, then tighten nuts on screws (11).
19. Place spacer (15) and rod end (7) on bracket (2). Secure with screw (16) and new locknut (17).
20. Place spacer (18) and rod end (8) on generator (13). Secure with screw (19) and new locknut (20).
21. Connect cable (21) to generator (13).

NOTE

Use straightedge across face of both pulleys to assist in proper alignment.

18. To obtain correct alignment, adjust the position of the generator mounting bracket (10) before you tighten the screws (11) in the slotted holes. Align pulley (12), on generator (13), with drive pulley (14), on the transfer gearcase, to within 1/8 inch, then tighten nuts on screws (11).

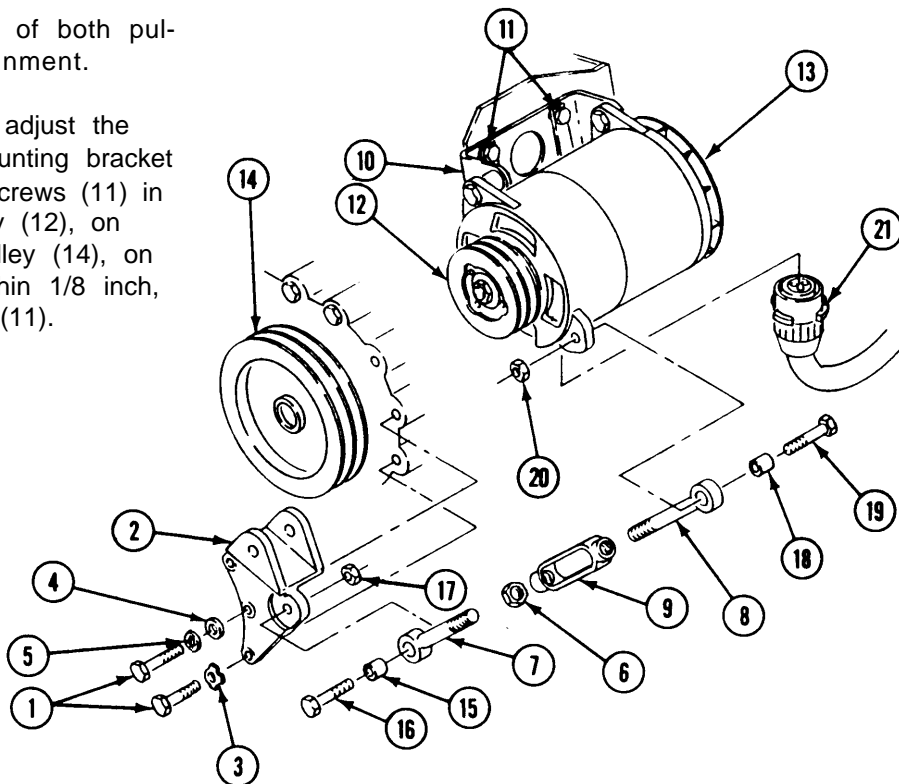

FOLLOW-THROUGH STEPS

1. Connect battery ground lead (page 13-2).
2. Install generator drive belts (page 9-29).
3. Check output of generator (page 3-2).
4. Stop/shutdown engine (see your -10).
5. Install power plant rear access panels and support (page 24-27).

END OF TASK

REPLACE GENERATOR AND ADJUSTMENT LINKAGE (200 AMP GENERATOR ONLY)

DESCRIPTION

This task covers: Remove (page 9-34). Install (page 9-36).

INITIAL SETUP

Tools:

General Mechanics Tool Kit (Item 30, App D)
 Socket Wrench Set (Item 89, App D)
 Torque Wrench (Item 95, App D)
 Wood Block, 2 inches x 4 inches x 3 feet

Materialparts:

Antiseize compound (Item 4, AppC)
 Cotter pin (2)
 Key washer (2)
 Lockwasher (2)
 Self-locking nut (2)
 Self-locking nut
 Self-locking nut

Personnel Required:

Unit Mechanic
 Helper (H)

References:

See your -10

Equipment Conditions:

Engine stopped/shutdown (see your -10)
 Carrier blocked (see your -10)
 Battery ground lead(s) disconnected
 (page 13-2)
 Power plant rear access panels removed
 (page 24-29)
 Generator drive belts removed (page 9-29)
 Fan drive belts removed (page 8-35)

REMOVE

1. Remove locknut (1), screw (2), generator ground lead (3), two washers (4), and starter ground lead (5) from bracket (6). Discard locknut.
2. Deleted.

3. Disconnect cable (7) from generator (8). Remove nut (9), lockwasher (10), and generator ground lead (3) from generator. Discard lockwasher.

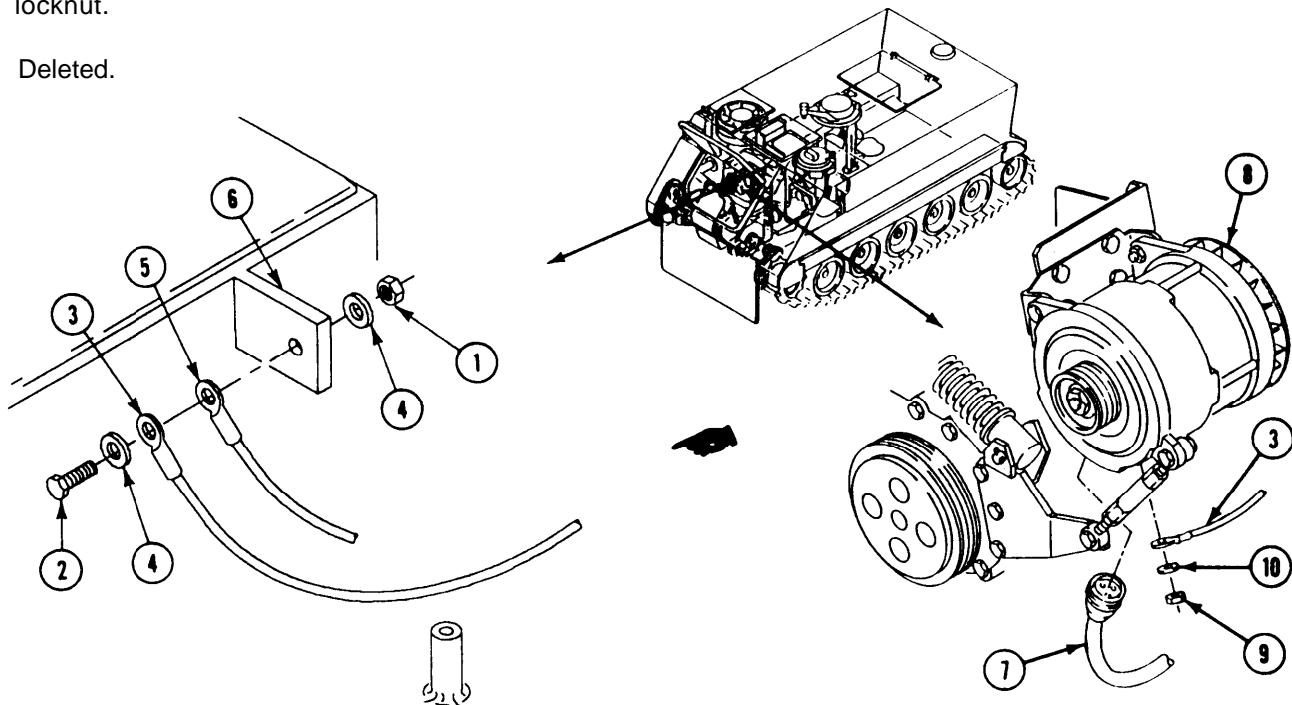

4. Remove two cotter pins (1), pin (2), and fan drive tensioner (3) from bracket (4) on transfer gearcase. Discard cotter pins.
5. Remove locknut (5), screw (6), rod end (7), and spacer (8) from bracket (4). Discard locknut.
6. Remove locknut (9), screw (10), rod end (11), and spacer (12) from generator (13). Discard locknut.
7. Remove two rod ends (7 and 11) from tumbuckle (14). Remove jam nut (15) from rod end (7).
8. Remove three screws (16), two key washers (17), one lockwasher (18), one flat washer (19), and bracket (4) from transfer gearcase. Discard key washers and lockwasher.

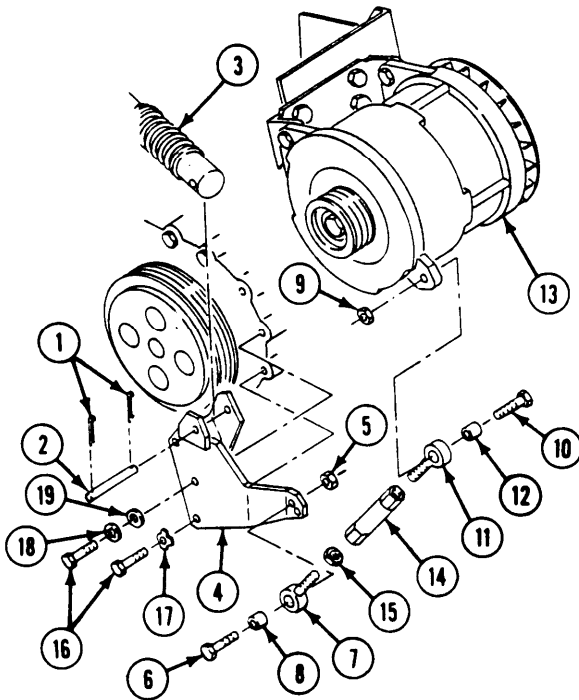

NOTE

It may be necessary to loosen two screws (20) and swing generator up to remove lower screws (21) from generator mounting bracket.

9. Support generator with wood block and remove two lower screws (21) and washers (22) from generator mounting bracket (23).

10. Remove two upper screws (21), washers (22), and generator mounting bracket (23) from fuel filter bracket (24).
11. Remove generator (13) and attached mounting bracket (23) horn power plant compartment. Have helper assist.

NOTE

If replacing generator, do steps 12 through 16.

12. Remove three screws (25) that secure pulley (26) and bushing (27) to generator shaft (28).
13. Install three screws (25) in threaded holes in pulley (26). Tighten screws until bushing (27) separates from pulley.
14. Remove pulley (26) and bushing (27) from generator shaft (28).
15. Remove key (29) from generator shaft (28).
16. Remove two locknuts (30), washers (31) and screws (20) from generator (13) and mounting bracket (23). Remove bracket from generator. Discard locknuts.

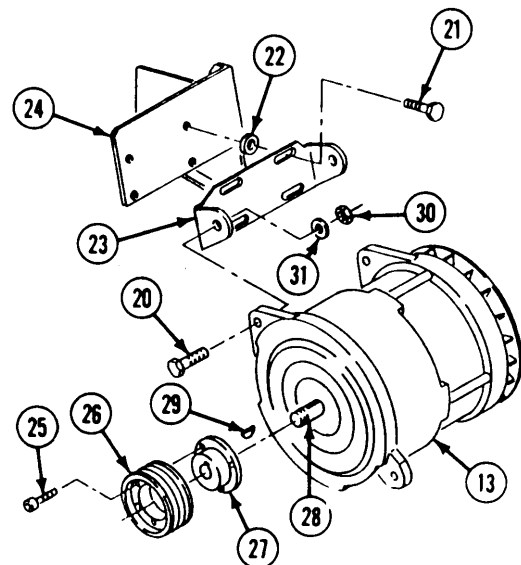

GO TO NEXT PAGE

INSTALL

NOTE

If installing new generator, begin with step 17. If not installing new generator, go to step 20.

17. Install generator mounting bracket (1) on generator (2). Secure with two screws (3), washers (4), and new locknuts (5). Do not tighten.
18. Install key (6) in generator shaft (7).

NOTE

Position pulley as close to the generator body as possible. Tighten three screws (10) alternately and progressively until they are pulled up tight.

19. Install bushing (8) and pulley (9) on generator shaft (7). Secure with three screws (10).
20. Place generator (2) and mounting bracket (1) on right side sponson in engine compartment.
21. Support generator (2) with 2-inch x 4-inch x 3-foot wood block and align slotted holes in generator mounting bracket with holes in fuel filter bracket (11). Secure with four washers (12) and screws (13). Do not tighten screws.

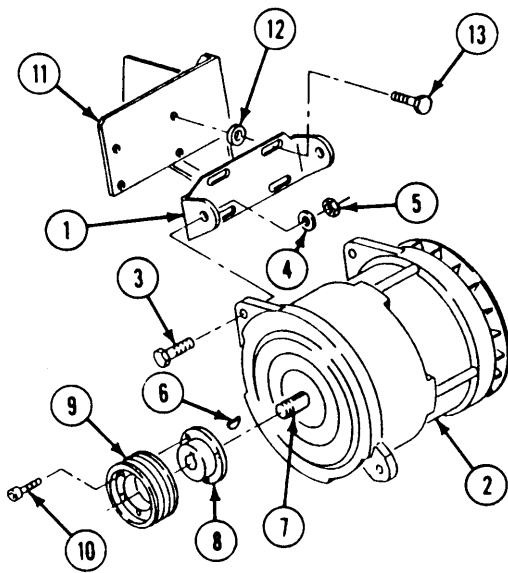

22. Coat threads of three screws (14) with anti-seize compound.
23. Install bracket (15) on transfer gearcase. Secure with two new key washers (16), flat washer (17), new lockwasher (18) and three screws (14). Tighten screws to 144–192 lb-in (16-22 N.m) torque. Use torque wrench and socket wrench set. Bend tabs on key washers.
24. Place jam nut (19) on rod end (20). Assemble rod ends (20, 21) in turnbuckle (22). Do not tighten jam nut.
25. Install turnbuckle rod end (21) on generator (2). Secure with spacer (23), screw (24), and new locknut (25).
26. Secure rod end (20) to bracket (15) with screw (26), spacer (27), and new locknut (28).
27. Assemble fan drive tensioner (29) and install on bracket (15). Secure with pin (30) and two new cotter pins (31).

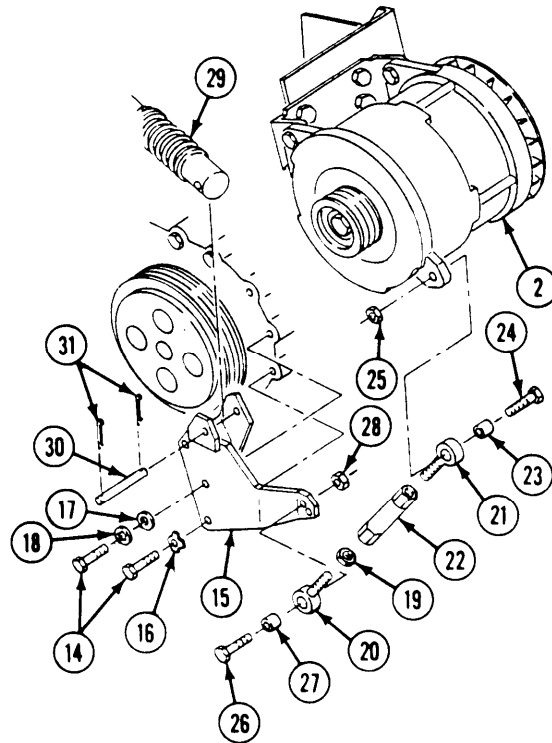

28. Place generator drive belt (1) on pulleys (2, 3).

NOTE

Use straightedge across face of both pulleys to assist in proper alignment.

29. To obtain correct alignment, adjust the position of the generator mounting bracket (4) before you tighten the screws (5) in the slotted holes. Align pulley (2), on generator (6), with drive pulley (3), on the transfer gearcase, then tighten screws (5).
30. Turn turnbuckle (7) until belt deflection at midspan is 1/2–5/8 inch (13-16 mm) when force is applied.

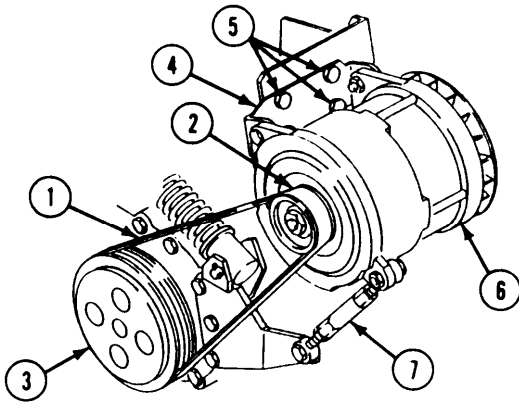

31. Tighten jam nut (8) on turnbuckle (7). Tighten two nuts (9) on screws (10) that secure generator (6) to generator mounting bracket (4).

32. Connect cable (11) to generator (6).

33. Install ground lead (12) on generator (6). Secure with new lockwasher (13) and nut (14).

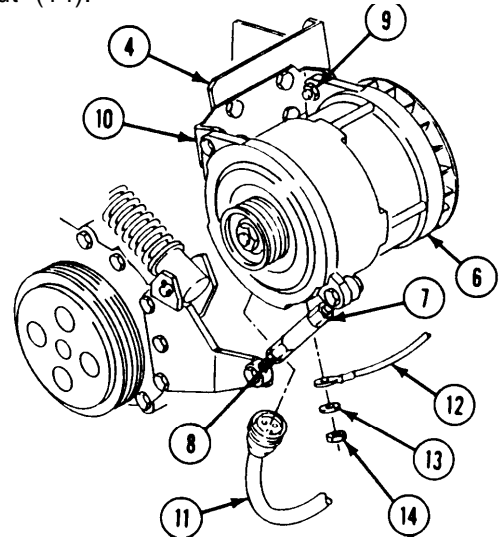

34. Deleted.

35. Install starter ground lead (15) and generator ground lead (12) on bracket (16). Secure with two washers (17), screw (18), and new locknut (19).

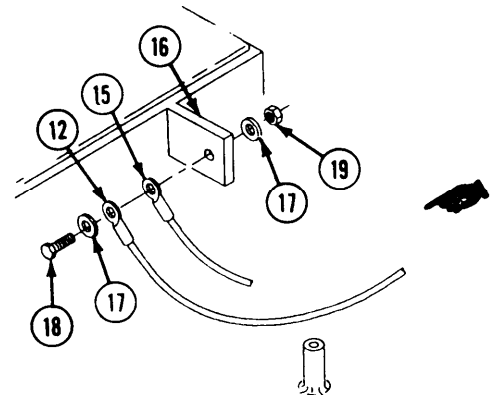

FOLLOW-THROUGH STEPS

- | | |
|---|--|
| <ol style="list-style-type: none"> 1. Connect battery ground lead (page 13-2). 2. Install fan drive belts (page 8-35). 3. Install generator drive belts (page 9-29). 4. While engine is running, check to be sure that generator and linkage are installed correctly. | <ol style="list-style-type: none"> 5. Check generator output (page 3-2). 6. Stop/shutdown engine (see your-10). 7. Install power plant rear access panels (page 24-29). |
|---|--|

END OF TASK

ADJUST VOLTAGE REGULATOR (100/200 AMP GENERATOR)

INITIAL SETUP

Tools:

General Mechanics Tool Kit (Item 30, App D)
 Digital Multimeter (Item 43, App D)

Personnel Required:

Unit Mechanic

References:

See your -10
 TM 9-6140-200-14
 TM 9-2350-300-20-1

Equipment Conditions:

Engine stopped/shutdown (see your -10)
 Carrier blocked (see your -10)

ADJUST

NOTE

Check batteries to make sure they are fully charged (see TM 9-6140-200-14).

Refer to TM9-2350-300-20-1 for adjustment procedures for M741A1 with M163A1 weapon system installed.

1. Remove access screw (1) from regulator (2).

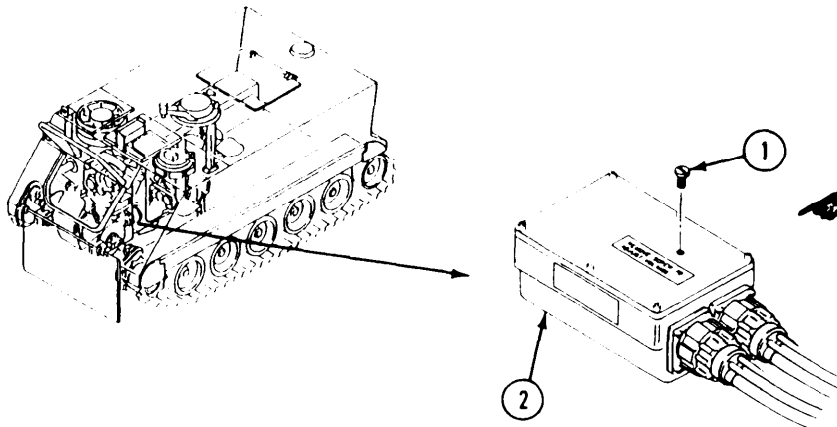

2. Start engine and allow to run for about 20 minutes with service headlights on (see your -10).
3. Turn off service headlights.
4. Set multimeter to read voltage on the 50V DC scale.

5. Remove receptacle cap (3).
6. Place red lead (4) in positive socket of NATO plug (5) on auxiliary power (slave) receptacle (6). Touch negative lead (7) to outside of NATO plug (8) on receptacle.

NOTE

On carriers that have standard auxiliary power receptacles touch red lead to positive and black lead to negative sockets in the receptacle.

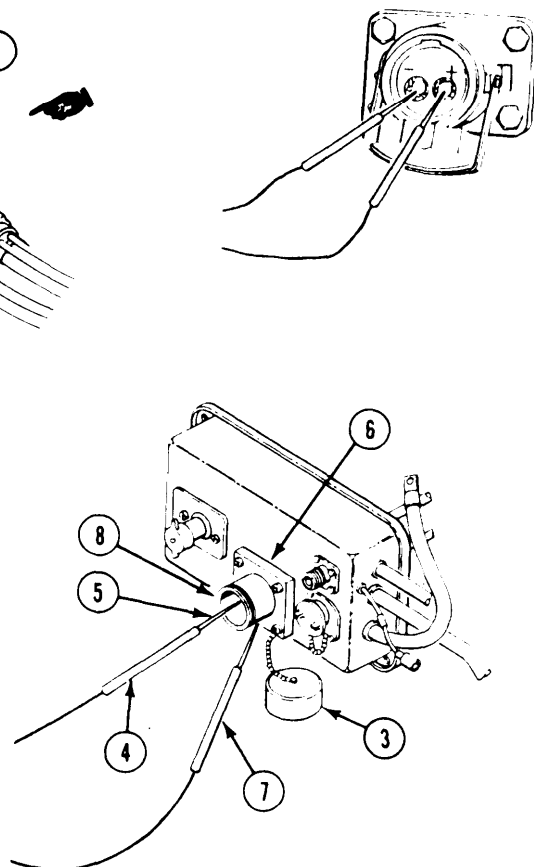

CAUTION

Battery can get overcharged and explode if the charging volts exceed 29. Adjust voltage regulator to 29 volts.

NOTE

Do not force adjusting screw past stop. If regulator cannot be adjusted, replace bad regulator.

Use insulated cross-tip screw driver #1 to adjust voltage.

90° and above:	27 V
50° thru 89°:	28 V
49° and below:	29 V

7. With engine operating at 900 to 1100 rpm, turn adjusting screw (1) in regulator (2) until proper voltage reading is achieved.
8. Install receptacle cap (3).
9. Install access screw (4) on regulator (2).

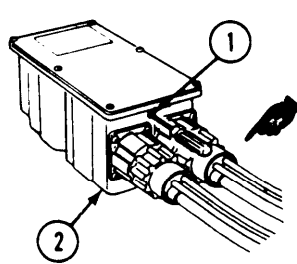

A. Vap-Air Model 26440001-03 (plug removed)

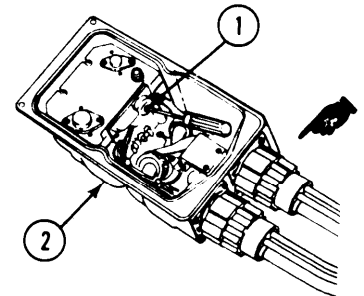

B. Vap-Air Model 26440001-04 (cover removed)

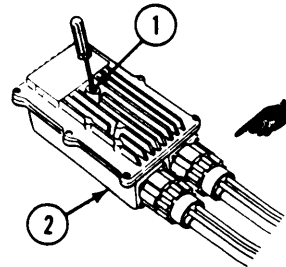

C. Leece-Neville Model 5027RC (plug removed)

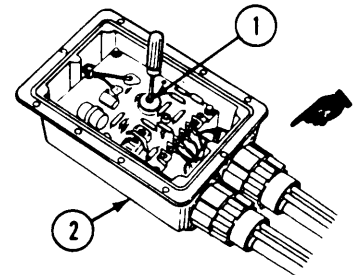

D. Leland Model 07639-CSV-2183-1 (cover removed)

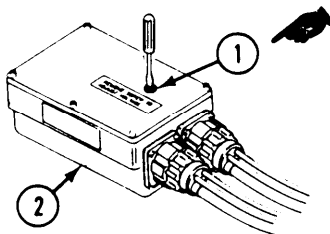

E. Prestolite Model REG-4000 (plug removed)

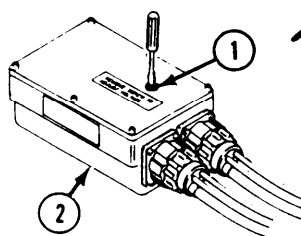

F. C. E. Niehoff Model N3019 (plug removed)

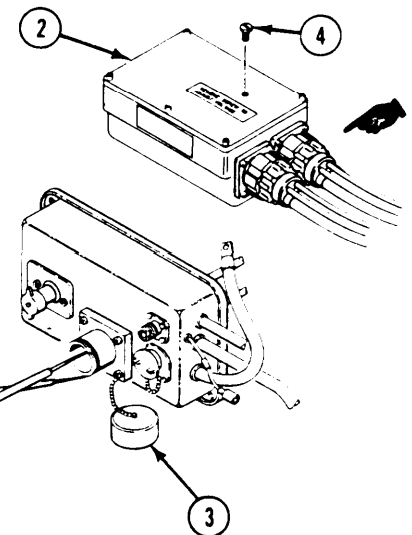

FOLLOW-THROUGH STEPS

1. Stop/shutdown engine (see your -10).

END OF TASK

REPLACE REGULATOR ASSEMBLY (100/200 AMP GENERATOR)

DESCRIPTION

This task covers: Remove (page 9-40). Clean, Inspect, and Repair (page 9-40). Install (page 9-41).

INITIAL SETUP

Tools:

General Mechanics Tool Kit (Item 30, App D)

References:

See your -10

Materials/Parts:

- Lockwasher (8)
- Lockwasher (8)
- Lockwasher (1)

Equipment Conditions:

- Engine stopped/shutdown (see your -10)
- Carrier blocked (see your -10)
- Battery ground lead disconnected (page 13-2)

Personnel Required:

Unit Mechanic 63T10

REMOVE

1. Disconnect two cannon plugs (1 and 2) from regulator (3).

NOTE

Ground lead is on 200 amp only.

2. Remove four screws (4), eight lockwashers (5), end of ground lead (6), and mount plate (7) with attached regulator (3) from hull weldnuts. Discard lockwashers.
3. Remove four screws (8), eight lockwashers (9), and mount plate (7) from regulator (3). Discard lo&washers.
4. Remove nut (10), lockwasher (11), and other end of ground lead (6) from ground stud (12) of regulator (3). Discard lockwasher.

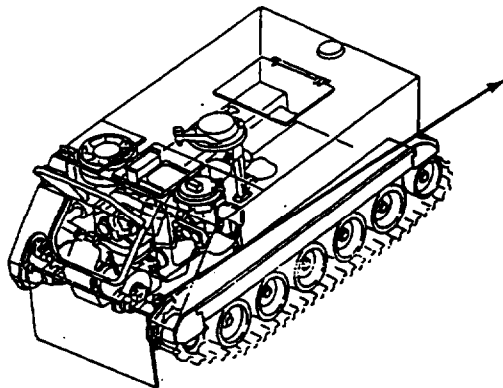

CLEAN, INSPECT, AND REPAIR

5. Check cables. Replace worn or cracked cables and damaged connectors (page 14-1).

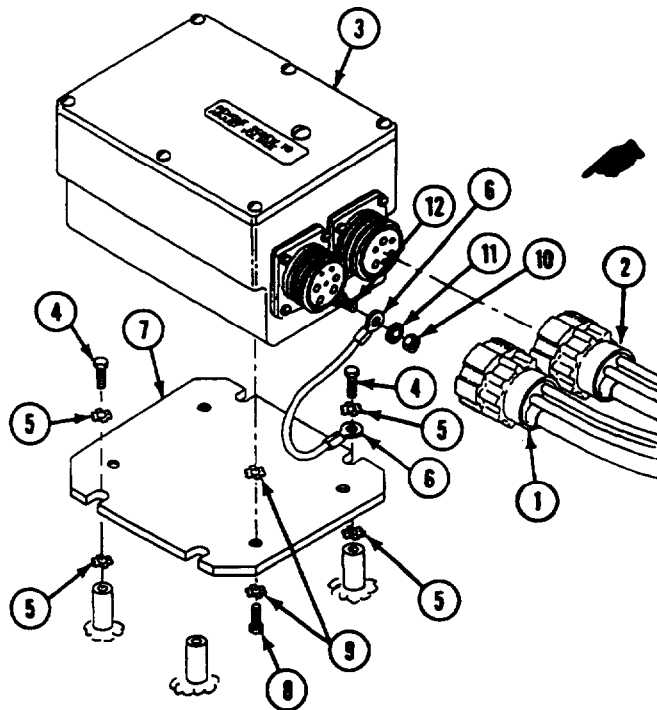

INSTALL

6. Place regulator (1) upside down and place four new lock washers (2) on holes (3). Set mount plate (1) on regulator and place four new lock washers (5) on holes (6). Secure mount plate to regulator with four screws (7).

NOTE

Ground lead is on 200 amp only.

7. Set regulator and mount plate assembly (8) on hull weldnuts (9). Slide from new lock washers (10) under mount plate (4) on hull weldnuts. Place four new lock washers (11) on mount plate over holes (12). Slide end of ground lead (13) under washer (11). Secure with four screws (14).
8. Place other end of ground lead (13) on ground stud (15). Secure with washer (16) and nut (17).
9. Connect two cannon plugs (18 and 19) to regulator (1).

FOLLOW-THROUGH STEPS

1. Connect battery ground lead (page 13-2).
2. Adjust regulator voltage (page 9-38).

END OF TASK

REPLACE GENERATOR-REGULATOR CIRCUIT BREAKER (100 AMP GENERATOR ONLY)

DESCRIPTION

This task covers: Remove (page 9-42). Clean, Inspect, and Repair (page 9-43).
Install (page 9-43).

INITIAL SETUP

Tools:

General Mechanics Tool Kit (Item 30, App D)

Materials/Parts:

Lockwasher (5)
Self-locking nut (8)
Self-locking nut (3)

References:

see your -lo

Equipment Conditions:

Engine stopped (see your -10)
Battery ground lead disconnected (page 13-2)
Carrier blocked (see your -10)

Personnel Required:

Unit Mechanic

REMOVE

1. Remove eight locknuts (1), washers (2), screws (3), and master switch panel (4) from distribution box (5). Discard locknuts.
2. Remove five screws (6), lockwashers (7), and distribution box (5) from hull mounts (8). Discard lockwashers.
3. Remove locknut (9), two washers (10), and screw (11) from terminal strip (12) and distribution box (5). Discard locknut.

NOTE

Some carriers have four lockwashers on circuit breaker.

4. Remove two screws (13), four/two lockwashers (14), terminal strip (12), and circuit 3 lead (15) from circuit breaker (16). Discard lockwashers.
5. Remove two locknuts (17), screws (18), and circuit breaker (16) from distribution box (5). Discard locknuts.

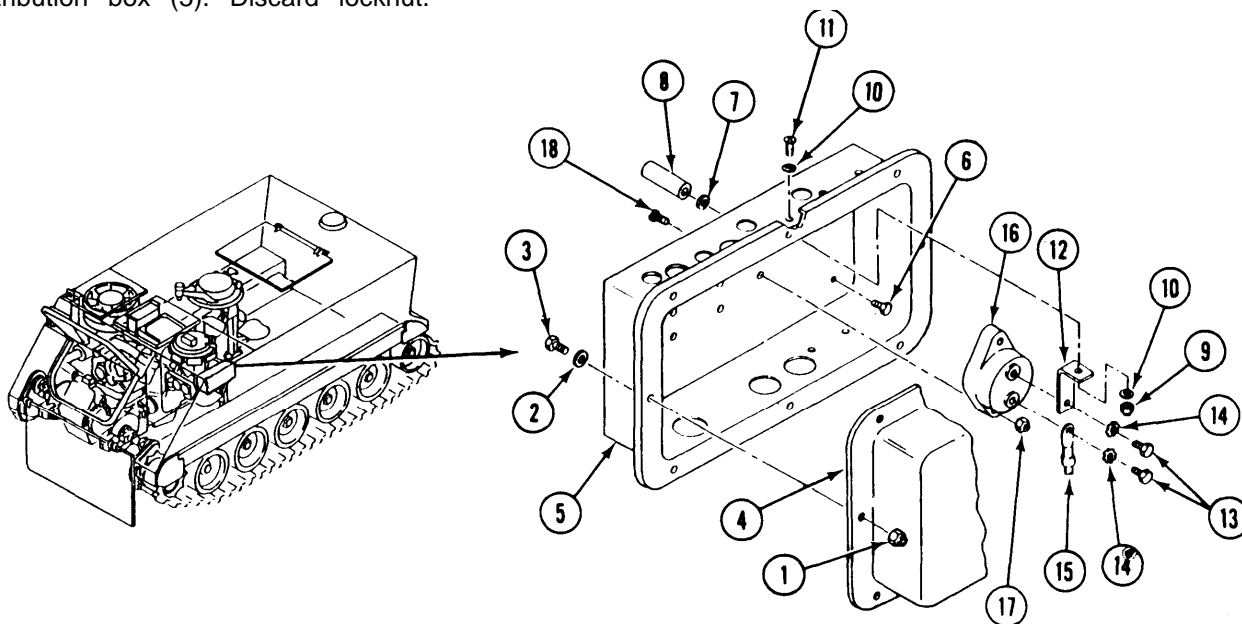

CLEAN, INSPECT, AND REPAIR

6. Check terminal strip. Replace circuit breaker that has cracked terminal strip.

INSTALL**NOTE**

When installing a new generator-regulator circuit breaker, discard two of the four lockwashers supplied with circuit breaker.

7. Place circuit breaker (1) in distribution box (2). Secure with two screws (3) and new locknuts (4).
8. Place circuit 3 lead (5) and terminal strip (6) on circuit breaker (1). Secure with two new lockwashers (7) and two screws (8).
9. Align terminal strip (6) with hole in distribution box (2). Secure with screw (9), two washers (10), and new locknut (11).
10. Place distribution box (2) on hull mounts (12). Secure with five new lockwashers (13) and screws (14).
11. Place master switch panel (15) on distribution box (2). Secure with eight screws (16), washers (17), and new locknuts (18).

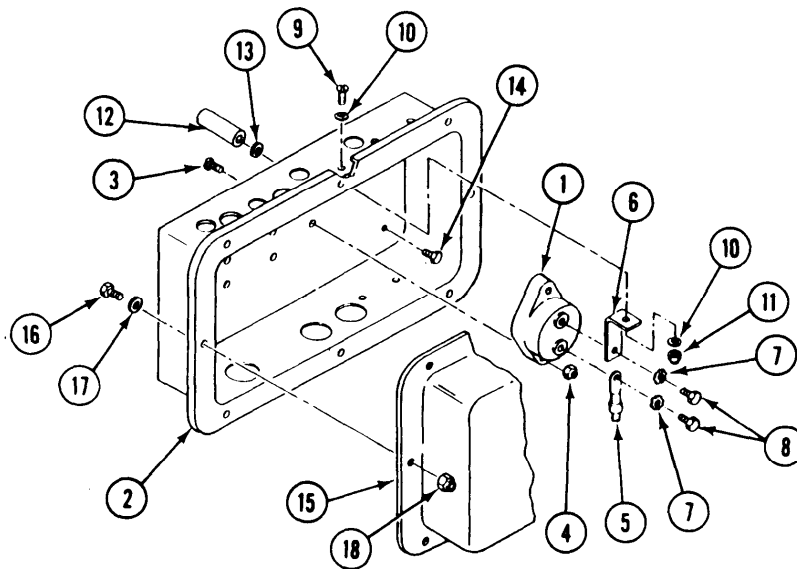
**FOLLOW-THROUGH STEPS**

1. Connect battery ground lead (page 13-2).
2. Start engine and check the generator-regulator circuit breaker. The BATT-GEN gage should be in green area (see your -10).
3. Stop engine (see your -10).

END OF TASK

REPLACE GENERATOR FIELD SWITCH

INITIAL SETUP

Tools:

General Mechanics Tool Kit (Item 30, App D)

References:

see your -10

Materials/Parts

Sealing compound (Item 46, App C)
Leads and connectors, as required

Equipment Conditions:

Engine stopped/shutdown (see your -10)
Carrier blocked (see your -10)
Rear power plant access panel removed
see your -10)

Personnel Required

Unit Mechanic

REMOVE

1. Disconnect circuit 1A/1B lead (1) from generator field switch (2).
2. Remove switch (2) from tee (3) on secondary fuel filter (4).

NOTE

Earlier switches may have a threaded pipe plug without a head or no plug at all. Discard the pipe plug with the switch. Do not reuse pipe plug because it can be installed too deeply and short out the new switch.

3. If replacing switch (2), remove bolt (5) and washer (6) from side of switch (2). Discard switch.

CLEAN, INSPECT, AND REPAIR

4. Check circuit lead. Replace worn or cracked lead and damaged connector (page 14-3).

INSTALL

5. If installing a new switch (2), coat threads on bolt (5) with sealing compound. Install washer (6) and bolt (5) on side of switch (2).
6. Coat threads of switch with sealing compound.

7. Install switch (2) on tee (3) on secondary fuel filter (4).

8. Connect circuit 1A/1B lead (1) to switch (2).

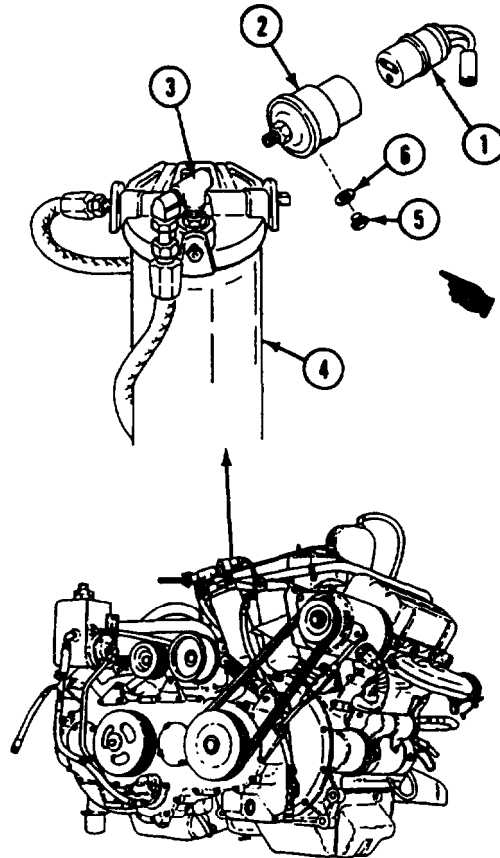

FOLLOW-THROUGH STEPS

1. Check operation of field switch (page 3-55).
 2. Install rear power plant access panel (see your -10).
-

END OF TASK

REPLACE FUEL FILTER MOUNTING BRACKET (M577A2 AND M1068 WITH 200 AMP GENERATOR ONLY)

DESCRIPTION

This task covers: Remove (page 9-45). Install (page 9-46).

INITIAL SETUP

Tools:

General Mechanics Tool Kit (Item 30, App D)
Torque Wrench (Item 97, App D)

Materials/Parts:

Antiseize compound (Item 4, App C)
Lockwasher (4)
screw (4)

Personnel Required:

Unit Mechanic

References:

see your -10

Equipment Conditions:

Engine stopped/shutdown (see your -10)
Carrier blocked (see your -10)
Ramp lowered (see your -10)
Battery ground lead disconnected (page 13-2)
Power plant rear access panel removed
(page 24-29)
Fan drive belts removed (page 3-35)
Primary fuel filter removed (page 6-129)
Secondary fuel filter removed (page 6-131)
Generator and mounting bracket removed
(page 9-31)

REMOVE

1. Remove screw (1), locknut (2), clamp (3), and field switch wire(4) from fuel filter mounting bracket(5). Discard locknut.

2. Remove four screws (6), lockwashers (7), and bracket (5) from engine. Discard screws and lockwashers.

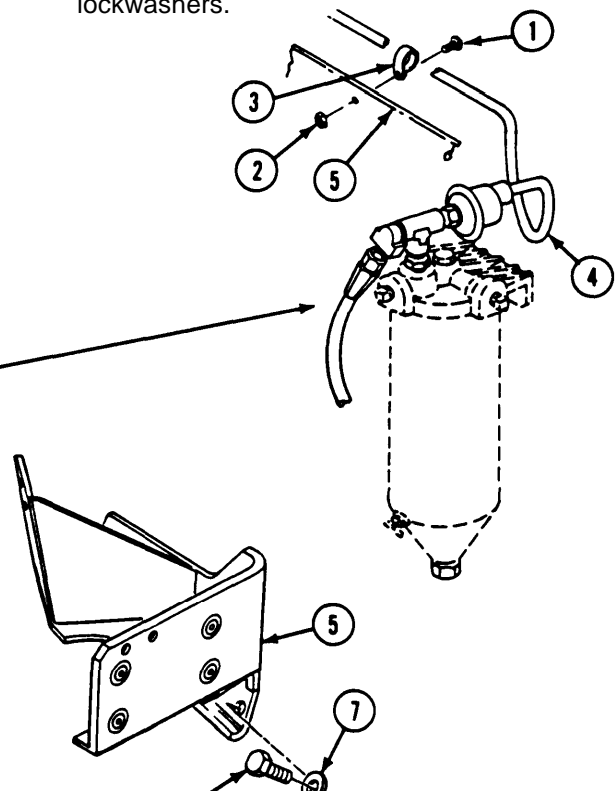
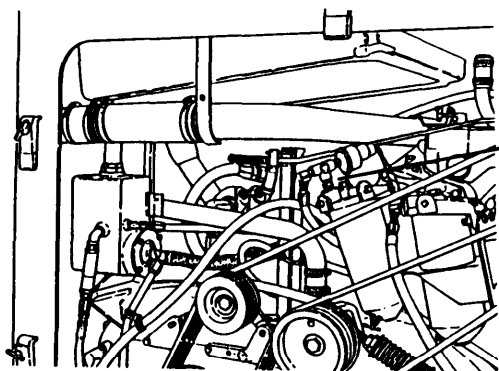

GO TO NEXT PAGE

INSTALL

NOTE

Generator (1), with bracket (2) and turnbuckle assembly (3) attached, must be placed on right side sponson prior to installing new fuel filter mounting bracket due to space restrictions.

3. Apply antiseize compound to threads of four new screws (4).

4. Install bracket (5) on engine. Secure with four new screws (4) and new lockwashers (6). Tighten screws to 50-55 lb-ft (60-75 N.m) torque. Use torque wrench.

5. Install clamp (7) with field switch wire (8) on bracket (5). Secure with screw (9) and new locknut (10).

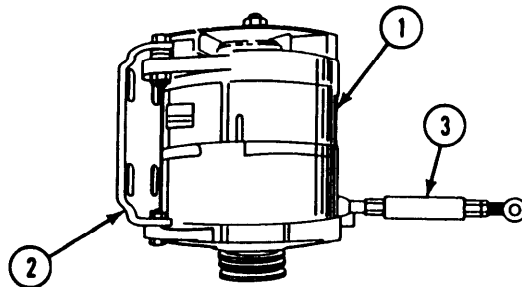
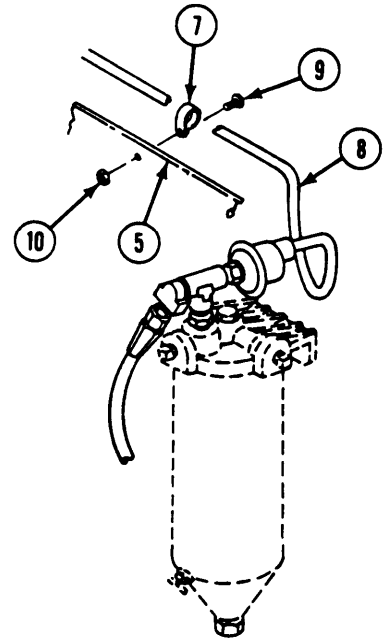
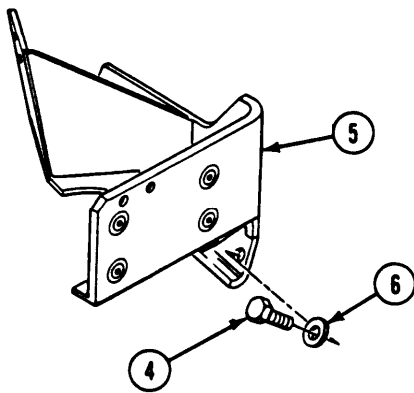

FOLLOW-THROUGH STEPS

- | | |
|--|--|
| 1. Install generator and mounting bracket (page 9-31). | 5. Install power plant rear access panel (page 24-29). |
| 2. Install secondary fuel filter (page 6-131). | 6. Connect battery ground lead (page 13-2). |
| 3. Install primary fuel filter (page 6-129). | 7. Raise and lock ramp (see your -10). |
| 4. Install fan drive belts (page 845). | 8. Stop/shutdown engine (see your -10). |

END OF TASK

REPLACE GENERATOR DRIVE BELTS (200 AMP GENERATOR ONLY)

DESCRIPTION

This task covers: Remove (page 9-47). Install (page 9-48).

INITIAL SETUP

Tools:

General Mechanics Tool Kit (Item 30, App D)

Personnel Required:

Unit Mechanic

References:

See your -10

Equipment Conditions:

Engine stopped/shutdown (see your -10)

Carrier blocked (see your -10)

Power plant rear access panels removed
(page 24-29)

Engine compartment cover support removed
(page 24-29)

REMOVE

1. Loosen jam nut (1) on rod end (2).
2. Loosen two screws (3) on generator mounting bracket.
3. Turn turnbuckle (4) to loosen drive belt (5).
4. Remove drive belt (5) from generator pulley assembly (6) and drive pulley (7).

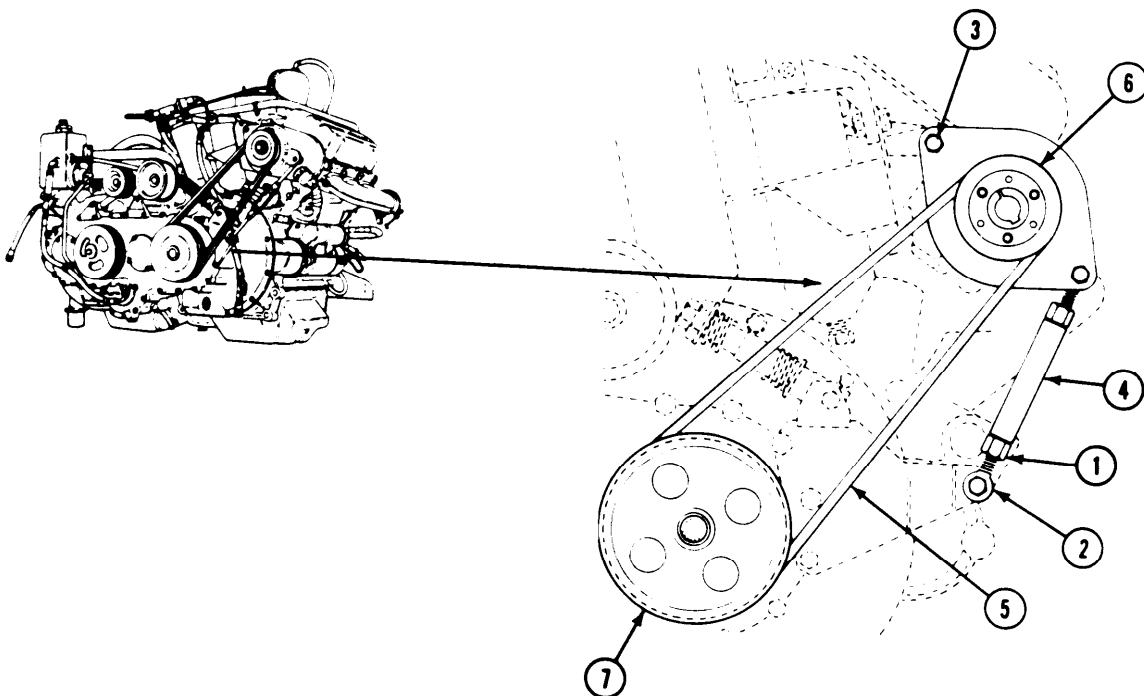

GO TO NEXT PAGE

INSTALL

5. Install drive belt (1) on drive pulley (2) and generator pulley (3).
6. Turn tumbuckle (4) and tighten belt until belt deflection at midspan is 1/2 to 5/8 inch (13 to 16 mm) when force is applied.

7. Tighten locknut (5) on rod end (6).
8. Tighten two screws (7) on generator mounting bracket.

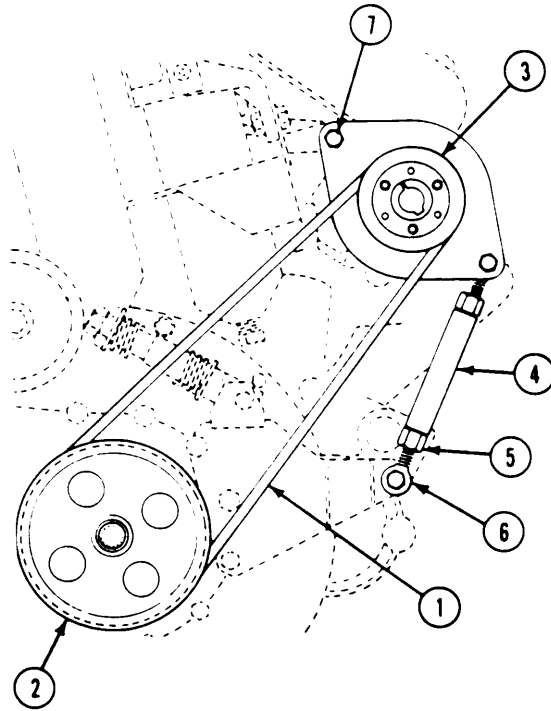

FOLLOW-THROUGH STEPS



WARNING

Wearing loose clothing around moving parts can allow personnel to get caught and could result in injury or death. Tuck in loose clothing.

1. start engine (see your -10). Check that generator drive belts are installed properly.

2. Stop/shutdown engine (see your -10).
3. Install engine compartment cover support (page 24-29).
4. Install power plant rear access panels (page 24-29).

END OF TASK

REPLACE MASTER SWITCH TO DISTRIBUTION BOX WIRE ASSEMBLY (CIRCUIT 49 LEAD) (M577A2 AND M1068 ONLY)

DESCRIPTION

This task covers: Remove (page 9-49). Clean, Inspect, and Repair (page 9-50).
Install (page 9-50).

INITIAL SETUP

Tools

General Mechanics Tool Kit (Item 30, App D)
Digital Multimeter (Item 43, App D)

Materials/Parts

Grommet (2)
Lockwashers (8)
Self-locking nut (8)
Self-locking nut

Personnel Required:

Unit Mechanic

References

see your -10

Equipment Conditions

Engine stopped (see your -10)
Carrier blocked (see your -10)
Battery ground lead disconnected (page13-2)

REMOVE

1. Remove eight locknuts (1), washers (2), screws (3), and master switch panel (4) from distribution box (5). Discard locknuts.
2. Remove locknut (6), washer (7), and circuit 49 lead (8) from master switch terminal (9). Discard locknut.
3. Remove screw (10), lockwasher (11), and circuit 49 lead (9) from distribution box bus bar (12). Discard lockwasher.
4. Remove circuit 49 lead (8) with two grommets (13) from master switch panel (4) and distribution box (5). Discard grommets.

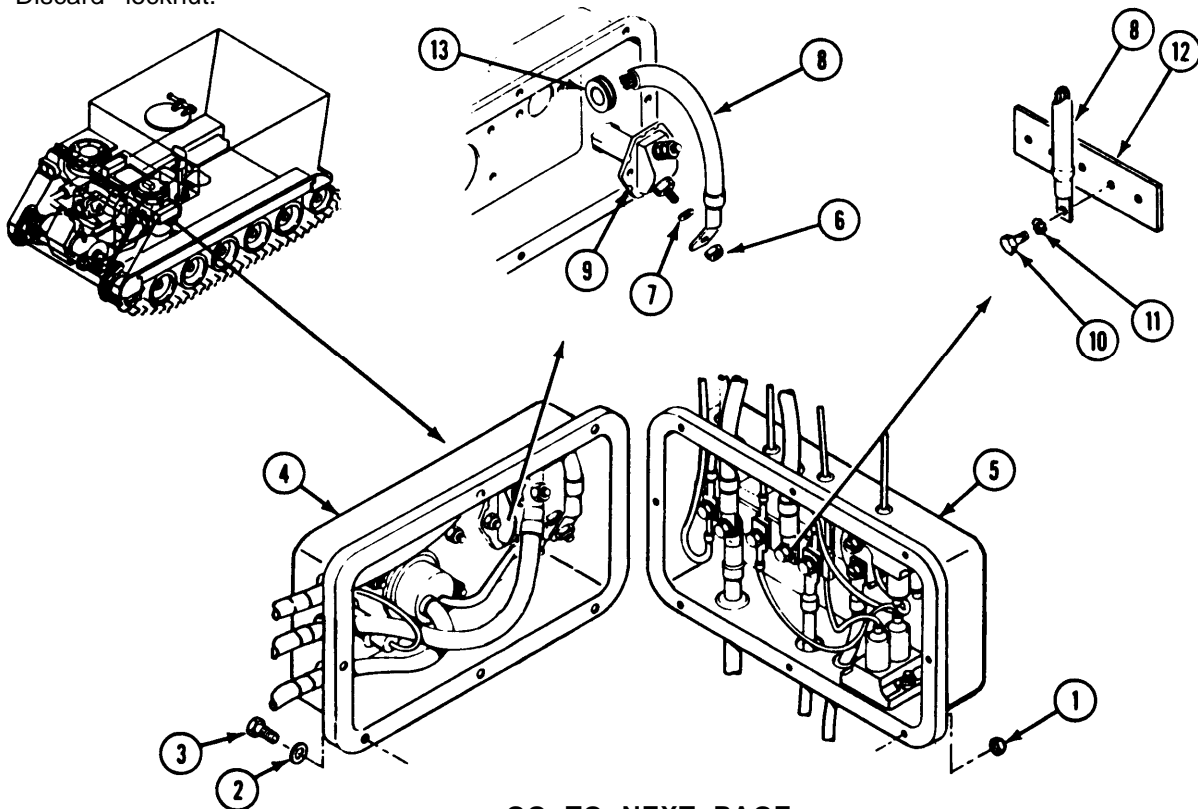

GO TO NEXT PAGE

CLEAN, INSPECT, AND REPAIR

5. Check circuit 49 lead for continuity. Use multimeter. Replace bad lead.

INSTALL

6. Install two new grommets (2) on circuit 49 lead (1).
7. Route circuit 49 lead (1) through distribution box (4) and master switch panel (3). Install new grommets (2) in box and panel.

8. Install circuit 49 lead (1) on bus bar (5) of distribution box (4). Secure with new lockwasher (6) and screw (7).
9. Install circuit 49 lead (1) on master switch terminal (8). Secure with washer (9), and new locknut (10).
10. Install master switch panel (3) on distribution box (4). Secure with eight screws (11), washers (12), and new locknuts (13).

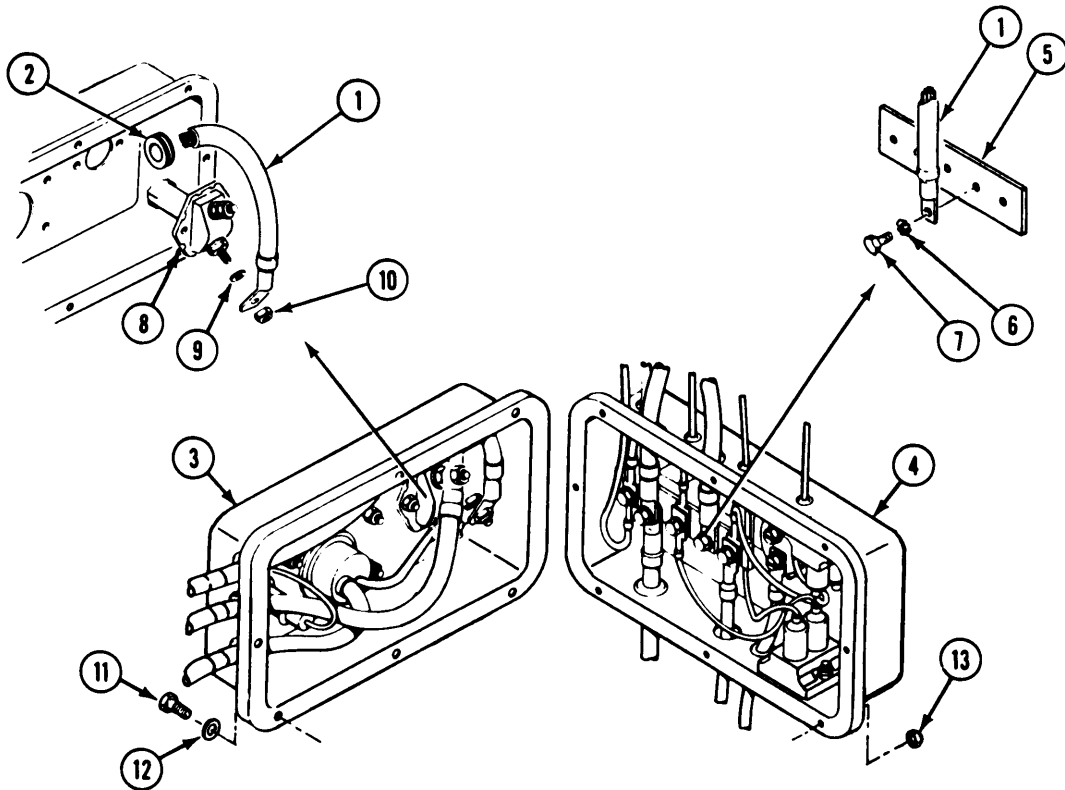

FOLLOW-THROUGH STEPS

1. Connect battery ground lead (page 13-2).
2. Turn MASTER SWITCH ON (see your -10).
3. Check that circuit 49 lead is operational. MASTER SWITCH light should come on.
4. Turn MASTER SWITCH OFF (see your-10).

END OF TASK

**CHAPTER 10
STARTER SYSTEM MAINTENANCE**

TASK INDEX

<u>Task</u>	<u>Page</u>	<u>Task</u>	<u>Page</u>
Replace Starter	10-2	Replace Starter Ground Leads	10-4

REPLACE STARTER

DESCRIPTION

This task covers: Remove (page 10-2). Clean, Inspect, and Repair (page 10-2.1).
 Install (page 10-2.1). Alternate Remove Method (10-2.2). Alternate Install Method (10-2.3).

INITIAL SETUP

Tools:

- General Mechanics Tool Kit Item 30, App D)
- Torque Wrench (Item 96, App D)
- Steel rods (2) (Item 59.1, App D)

Materials/Parts

- Gasket
- Lockwasher (3)
- Lockwasher (4)

Personnel Required:

- Unit Mechanic
- Helper (H)

References:

See your -10

Equipment Conditions:

- Engine stopped/shutdown (see your -10)
- Carrier blocked (See your -10) *if alternate method is used
- Battery ground leads disconnected (page 13-2)
- Power plant removed (page 5-12) (if rods are not available)
- Trim vane lowered (See your -10) *
- Power plant front access (See your -10) *
- Door opened and right side exhaust pipe removed (page 7-16) *

REMOVE

NOTE

If power plant is in vehicle and steel rods are available, go to step 12 to use alternative method. A helper is needed.

1. Remove nut (1), lockwasher (2), and two ground leads (3) from terminal on starter (4). Discard lockwasher.
2. Remove nut (5), lockwasher (6), and circuit 6 lead (7) from terminal on starter solenoid (8). Discard lockwasher.

3. Remove nut (9) (screw on Prestolite), two lockwashers (10) (Delco and Leece Neville only) and circuit 74A lead (11) from terminal on solenoid (8). Discard lockwashers.



WARNING

Avoid injury. Get an assistant to help you lift the starter or use a hoist. Starter weighs about 75 pounds (34 kg).

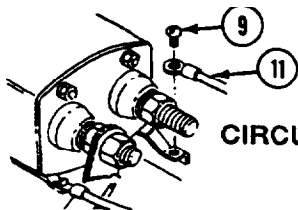

CIRCUIT 74A

PRESTOLITE

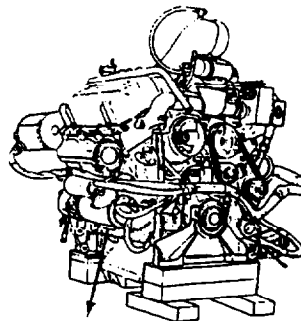

CIRCUIT 6

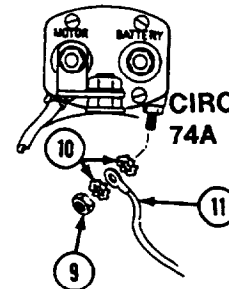

DELCO REMY

CIRCUIT 74A

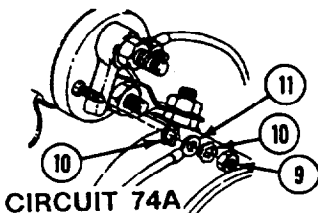

CIRCUIT 74A

LEECE NEVILLE

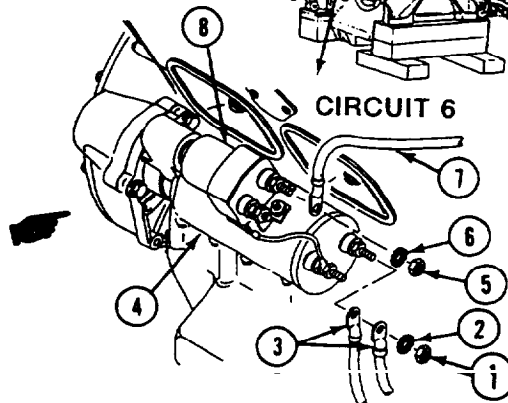

- Remove three bolts (1), lockwashers (2), starter (3) with solenoid (4), and gasket (5) (if installed) from engine (6). Discard lockwashers.

CLEAN, INSPECT, AND REPAIR

- Check starter drive teeth. Remove burrs. Replace starter that has damaged teeth or teeth worn beyond original shape.

NOTE

Check that starter-to-engine housing gasket is in place. Gasket is necessary to keep water out of starter.

INSTALL

- Install gasket (5) on engine (6).
- Place starter (3) with solenoid (4) on engine (6). Secure with three new lockwashers (2) and three bolts (1). Tighten screws to 137-147 lb-ft (186-199 N•m) torque. Use torque wrench.
- Install two new lockwashers (7) (Delco and Leece Neville only) and circuit 74A lead (8) on terminal of starter solenoid (4). Secure with nut (9) (screw on Prestolite).
- Install new lockwasher (10) and circuit 6 lead (11) on terminal of solenoid (4). Secure with nut (12).
- Install new lockwasher (13) and two ground leads (14) on terminal of starter (3). Secure with nut (15).
- Go to follow-through steps (items 1 thru 4) (page 10-2.3).

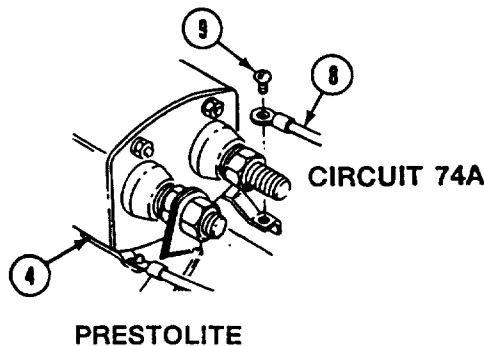
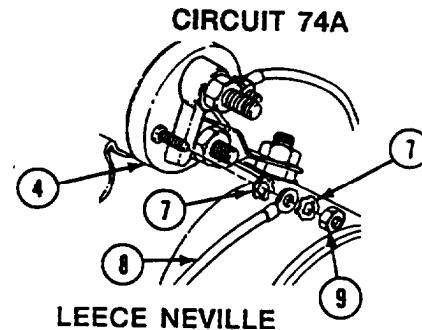
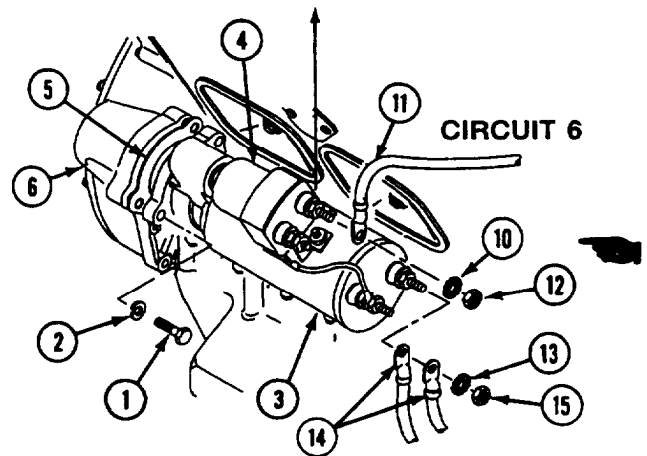
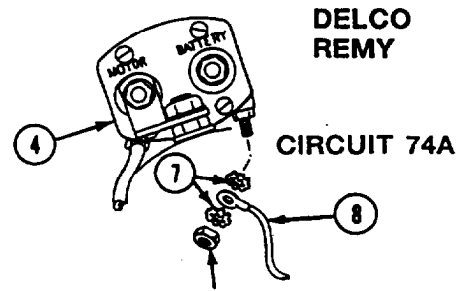

GO TO NEXT PAGE

ALTERNATE REMOVE

12. Remove exhaust pipe (see page 7-16).
 13. Remove nut (1), lockwasher (2), and two ground leads (3) from terminal on starter (4). Discard lockwasher.
 14. Remove nut (5) lockwasher (6), and circuit 6 lead (7) from terminal on starter solenoid (8). Discard lockwasher.
 15. Remove nut (9) (screw on Prestolite), two lockwashers (10) (Delco and Leece Neville only) and circuit 74A lead (11) from terminal on solenoid (8). Discard lockwashers.
 16. Remove engine low pressure oil switch see page 15-2).
- WARNING**
 Avoid injury. Get an assistant to help you lift the starter or use a hoist. Starter weighs about 75 pounds (34 kg).
17. Remove two of three bolts (12) and lockwashers (13). Discard lockwashers.
 18. Thread two steel rods into bolt holes.
 19. Remove third bolt (12) and lockwasher (13). Discard lo&washer.
 20. Slide starter (4) with solenoid (8) and gasket (14), if installed, down bars so it can be removed. Discard gasket.

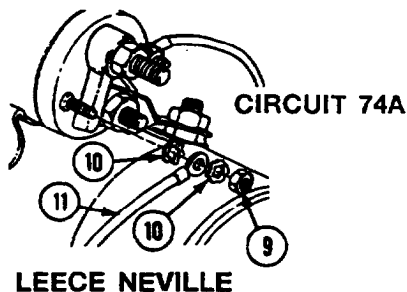
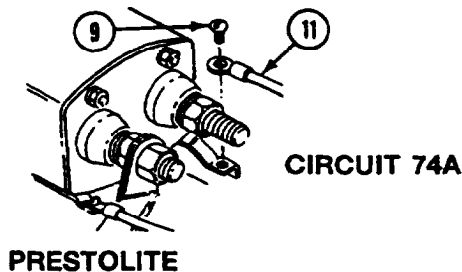
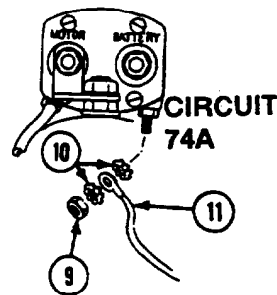
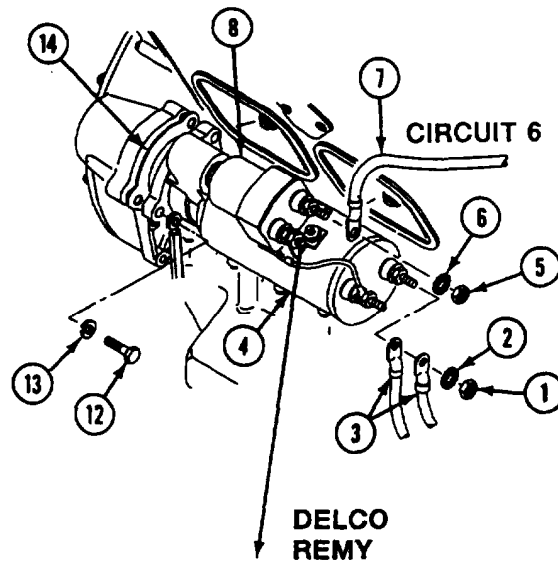
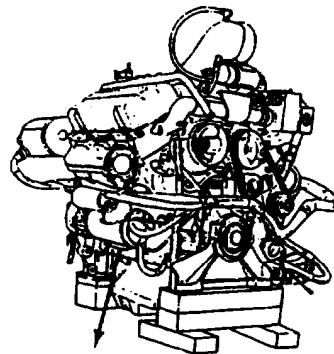

CLEAN, INSPECT, AND REPAIR

21. Check starter drive teeth. Remove burrs. Replace starter that has damaged teeth or teeth worn beyond original shape.

NOTE

Check that starter-to-engine housing gasket is in place. Gasket is necessary to keep water out of starter.

ALTERNATE INSTALL

22. Install new gasket (1) on engine (2).
23. Slide starter (3) with solenoid (4) on steel rods up to the flywheel. Secure with one new lockwasher (5) and bolt (6) to hold in place.
24. Remove two steel rods from threaded holes and install remaining two new lockwashers (5) and bolts (6). Tighten all three bolts to 137-147 lbft torque. Use torque wrench.
25. Install two new lockwashers (7) (Delco and Leece Neville only) and circuit 74A lead (8) on terminal of starter solenoid (4). Secure with nut (9) (screw on Prestolite).
26. Install new lockwasher (10) and circuit 6 lead (11) on terminal of solenoid (4). Secure with nut (12).
27. Install new lockwasher (13) and two ground leads (14) on terminal of starter (3). Secure with nut (15).

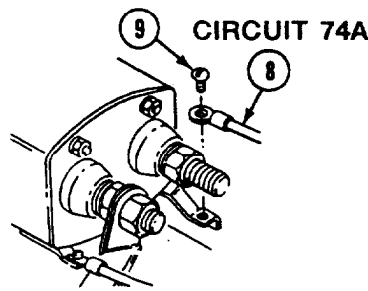
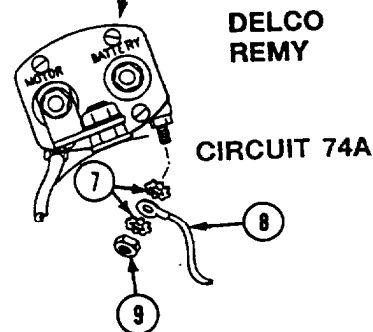
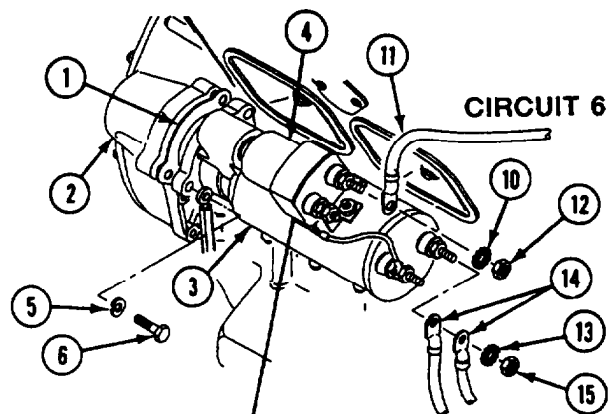

PRESTOLITE

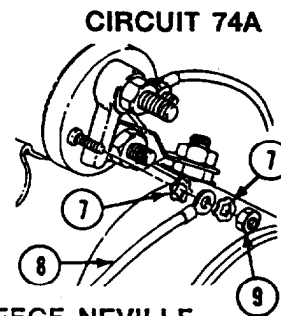

LEECE NEVILLE

28. Install exhaust pipe (see page 7-16).

FOLLOW-THROUGH STEPS

1. Install power plant (page 5-12) (if removed).
2. Connect battery ground leads (page 13-2).
3. Start engine. Check that starter is operable (see your -10).
4. Stop/shutdown engine (see your -10).

END OF TASK

REPLACE STARTER GROUND LEADS

DESCRIPTION

This task covers: Remove (page 10-4). Clean, Inspect, and Replace (page 10-5).
Install (page 10-5).

INITIAL SETUP

Tools:

General Mechanics Tool Kit (Item 30, App D)

References:

see your -lo

Materials/Parts:

Leads, as required
Self-locking nut

Equipment Conditions:

Engine stopped/shutdown (see your -10)
Carrier blocked (see your -10)
Trim vane lowered (see your -10)
Power plant front access door open
(see your -lo)
Battery ground leads disconnected (page 13-2)

Personnel Required:

Unit Mechanic

REMOVE

1. Remove nut (1), washer (2), short ground lead (3), and long ground lead (4) from starter (5).

NOTE

Some earner hull grounds may have star washers. Discard star washers and assemble ground leads with flat washers as instructed in the installation steps.

2. Remove screw (6), washer (7), and short lead (3) from engine block. Remove lead from earner.
3. Remove locknut (8), long lead (4), two washers (9), and screw (10) from hull mount. Remove lead from carrier. Discard locknut.

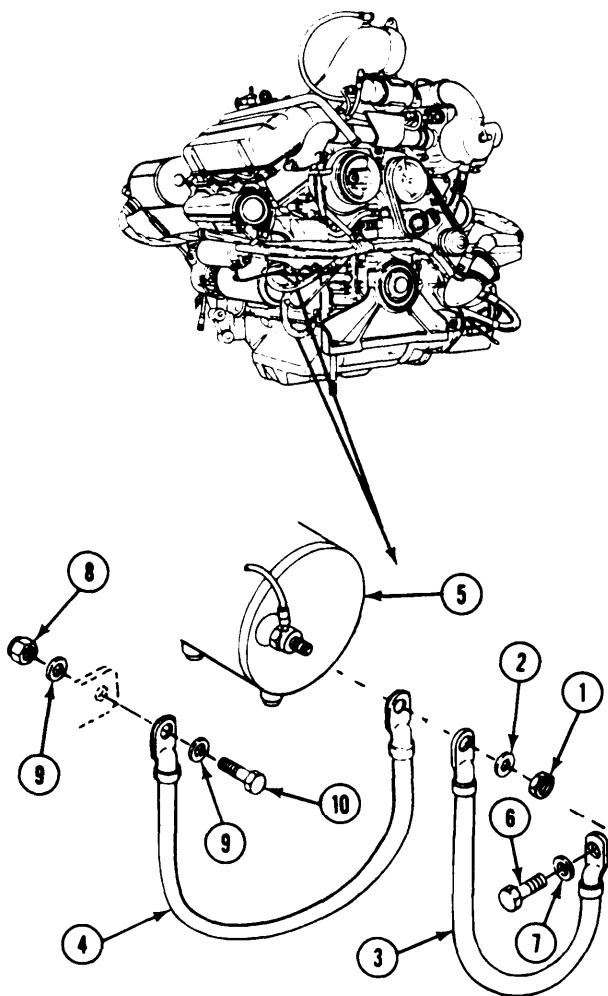

CLEAN, INSPECT, AND REPLACE

4. Remove paint, dirt, and corrosion from electrical contact areas on hull grounds.
5. Check leads. Replace leads that are worn or have cracked insulation.
6. Check lead connectors. Replace cracked or damaged connectors (page 14-3).

INSTALL

7. Place long ground lead (1) on hull mount. Secure with screw (2), two washers (3), and new locknut (4).
8. Place short ground lead (5) on engine block. Secure with washer (6) and screw (7).
9. Place two leads (1 and 5) and washer (8) on starter (9). Secure with nut (10).

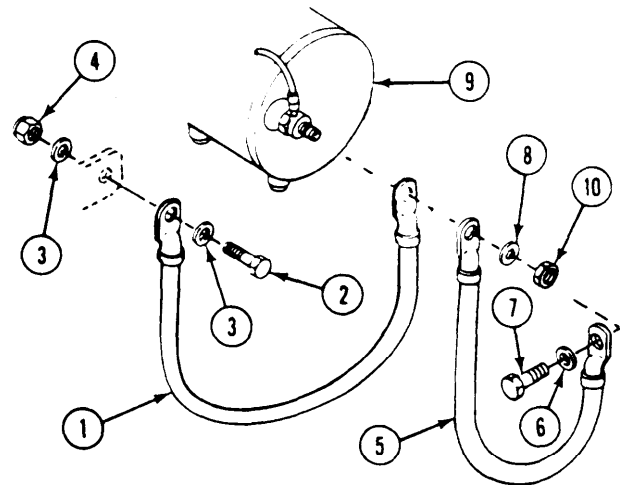

FOLLOW-THROUGH STEPS

1. Close power plant front access door (see your -lo).
2. Raise trim vane (see your -10).
3. Connect battery ground leads (page 13-2).
4. Start engine to check that starter ground leads are operable. Stop/shutdown engine (see your -lo).

END OF TASK

CHAPTER 11
ELECTRICAL SYSTEM MAINTENANCE — INSTRUMENT AND
WARNING LIGHT PANELS

Section I. INSTRUMENT PANEL

TASK INDEX

<u>Task</u>	<u>Page</u>	<u>Task</u>	<u>Page</u>
Replace Instrument Panel Mounts and Ground Lead	11-2	Replace Instrument Panel Tachometer	11-13
Replace Circuit Breaker	11-4	Replace Tachometer Cable and Adapter	11-14
Replace Panel and Indicator Lights	11-5	Replace Speedometer	11-16
Replace Instrument Panel ON-OFF Switches	11-7	Replace Speedometer Cable and Adapter	11-17
Replace Main Light Switch	11-9	Repair Speedometer Cable	11-19
Replace Engine Start Switch	11-10	Replace Fuel Select Switch to Gage Lead (M981 and M1064 Only)	11-20
Replace Instrument Panel Gages	11-11		

REPLACE INSTRUMENT PANEL MOUNTS AND GROUND LEADS

DESCRIPTION

This task covers: Remove (page 11-2). Install (page 11-3).

INITIAL SETUP

Tools:

General Mechanics Tool Kit (Item 30, App D)

Materials/Parts:

Lockwasher (4)
Self-locking nut (4)

Personnel Required:

Unit Mechanic

References:

See your -10
See your -24P

Equipment Conditions:

Engine stopped/shutdown (see your -10)
Battery ground lead disconnected (page 13-2)

REMOVE

1. Remove two locknuts (1), bottom mounts (2), screws (3), flat washers (4), and top mounts (5) from two struts (6 and 7) and instrument panel. Discard locknuts.
2. Support instrument panel and remove two bolts (8), ground lead (9), and two lockwashers (10) from two resilient mounts (11) and upper support bracket. Discard lockwashers.

3. Tip instrument panel forward and remove two bolts (12), ground lead (9), two lockwashers (13), and resilient mounts (11) from instrument panel. Discard lockwashers.
4. Remove two locknuts (14), washers (15), auxiliary power receptacle ground lead (16), two screws (17), short strut (6), and long strut (7) from hull mounts. Discard locknuts.

NOTE

Ground lead (16) is not installed on the M577A2 or M1068 instrument panel strut. ■

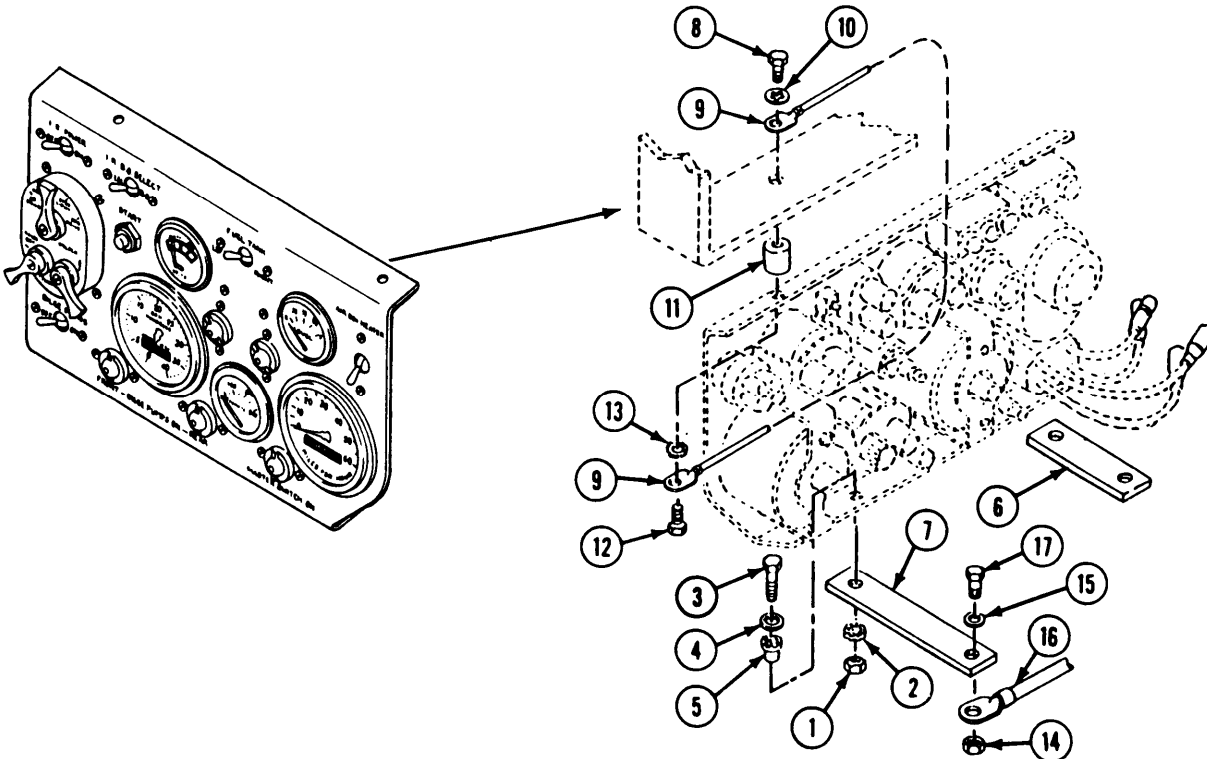

INSTALL

- Place two struts (1 and 2) on hull mounts. Secure with two screws (3), ground lead (4), two washers (5), and new locknuts (6).

NOTE

Ground lead (4) is not installed on the M577A2 instrument panel stint.

- Place two resilient mounts (7) on instrument panel. Secure with two new lockwashers (8), ground lead (9), and two bolts (10).
- Align mounts (7) with upper support bracket and secure with two new lockwashers (11), ground lead (9), and two bolts (12).
- Place two top mounts (13) between struts (1 and 2) and instrument panel. Secure instrument panel to struts with two screws (14), flat washers (15), bottom mounts (16), and new locknuts (17).

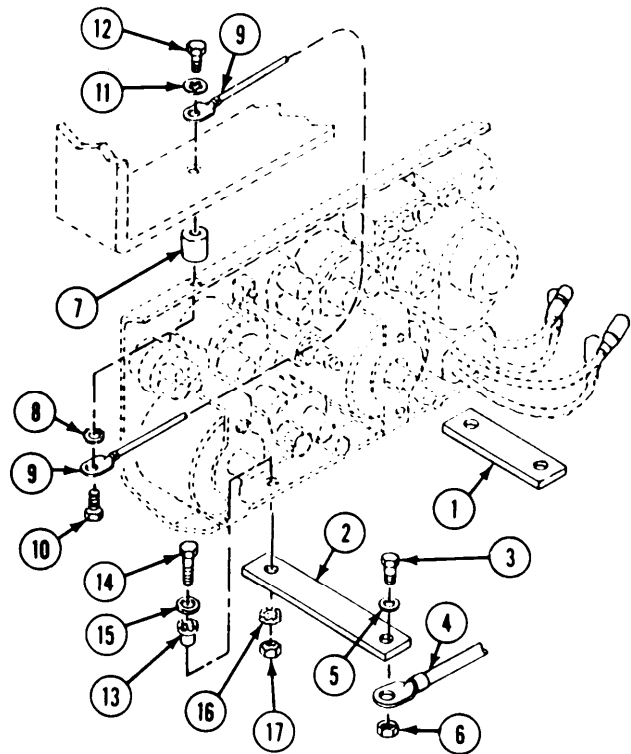
**FOLLOW-THROUGH STEPS**

- Connect battery ground lead (page 13-2).

END OF TASK

REPLACE CIRCUIT BREAKER

INITIAL SETUP

Tools:

General Mechanics Tool Kit (Item 30, App D)

Materials/Parts:

Self-locking nut (2)

Personnel Required:

Unit Mechanic

References

See your -10

Equipment Conditions:

Engine stopped/shutdown (see your -10)
 Carrier blocked (see your -10)
 Battery ground lead disconnected (page 13-2)
 Instrument panel removed (page 11-2)

REMOVE

1. Disconnect circuit 10 lead (1) and circuit 27 lead (2) from circuit breaker (3).
2. Remove two locknuts (4), screws (5), and circuit breaker (3) from rear of instrument panel. Discard locknuts.

INSTALL

3. Place circuit breaker (3) on rear of instrument panel. Secure with two screws (5) and new locknuts (4).
4. Connect circuit 27 lead (2) and circuit 10 lead (1) to circuit breaker (3).

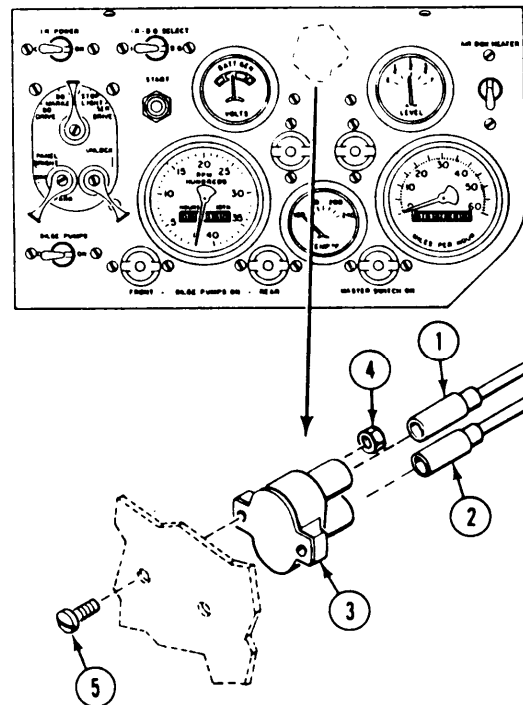

FOLLOW-THROUGH STEPS

1. Install instrument panel (page 11-2).
2. Connect battery ground lead (page 13-2).
3. Turn MASTER SWITCH ON, light should come on for proper installation of circuit breaker. (see your -10).
4. Turn MASTER SWITCH OFF (see your -10).

END OF TASK

REPLACE PANEL AND INDICATOR LIGHTS

DESCRIPTION

This task covers: Remove (page 11-5). Install (page 11-6).

INITIAL SETUP

Tools:

General Mechanics Tool Kit (Item 30, App D)

References:

see your -10

Materials/Parts:

Light bulb, as needed
Lockwasher (2)
Preformed packing, as needed

Equipment Conditions:

Engine stopped/shutdown (see your -10)
Carrier blocked (see your -10)
MASTER SWITCH OFF (see your -10)

Personnel Required:

Unit Mechanic

REMOVE

NOTE

There are two panel lights and three indicator lights on the instrument panel. Remove all lights the same way except for the number of leads.

1. Remove light bulb (1).
 - a. Turn lens (2) to the left. Remove lens (2) and preformed packing (3) from light assembly (4). Discard packing if damaged.
 - b. Push in and turn light bulb (1) to the left, and remove bulb (1) from light assembly (4).

NOTE

Do not disconnect more than one light at a time. Mark each lead to make sure you reconnect to correct contacts. See wiring diagram (FO-2).

2. If required, remove light assembly (4).
 - a. Disconnect circuit lead (5) from light assembly (4).
 - b. Remove two screws (6), lockwashers (7), and light assembly (4) from instrument panel. Discard lockwashers.

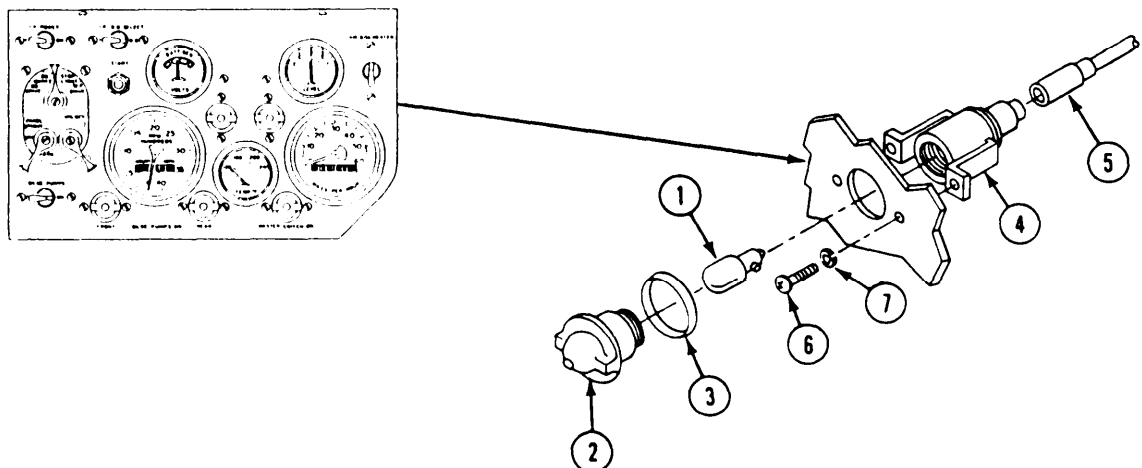

GO TO NEXT PAGE

INSTALL

3. If removed, install light assembly (1).

- a. Place light assembly (1) on rear of instrument panel. Secure with two new lockwashers (2) and screws (3).

NOTE

Make sure circuit leads are connected to correct lights. See wiring diagram (FO-2).

- b. Connect circuit lead (4) to light assembly (1).

4, Install light bulb (5).

- a. Install light bulb (5) in light assembly (1). Push and turn light bulb to the right to secure.
- b. Install new packing (6) if damaged and lens (7) in light assembly (1). Turn lens to the right to secure.

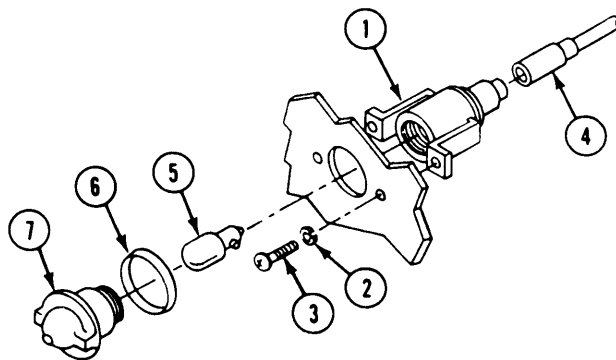

FOLLOW-THROUGH STEPS

1. Turn MASTER SWITCH ON (see your -10).
2. Turn panel light switch on, or bilge pump switch on, as needed, to check for proper installation of light assembly (see your -10).
3. Turn all panel switches OFF (see your -10).
4. Turn MASTER SWITCH OFF (see your -10).

END OF TASK

REPLACE INSTRUMENT PANEL ON-OFF SWITCHES

DESCRIPTION

This task covers: Remove (page 11-7). Install (page 11-8).

INITIAL SETUP

Tools:

General Mechanics Tool Kit (Item 30, App D)

References:

see your -10

Materials/Parts:

Lockwasher (10)

Equipment Conditions:

Engine stopped/shutdown (see your -10)

Carrier blocked (see your -10)

Battery ground lead disconnected (page 13-2)

Personnel Required:

Unit Mechanic

REMOVE

NOTE

There are four toggle switches on the instrument panel of all M113A2 FOV except the M981 which has five switches. Remove all toggle switches the same way, except for number of circuit leads.

Do not disconnect more than one switch at a time. Mark each circuit lead to make sure you reconnect to correct contacts. See wiring diagram foldouts.

1. Disconnect circuit leads (1) from rear of switch (2).

NOTE

If switch has guard, remove/install guard with steps 2 and 3.

2. Remove two screws (3), lockwashers (4), and toggle switch (2) from instrument panel. Discard lockwashers.

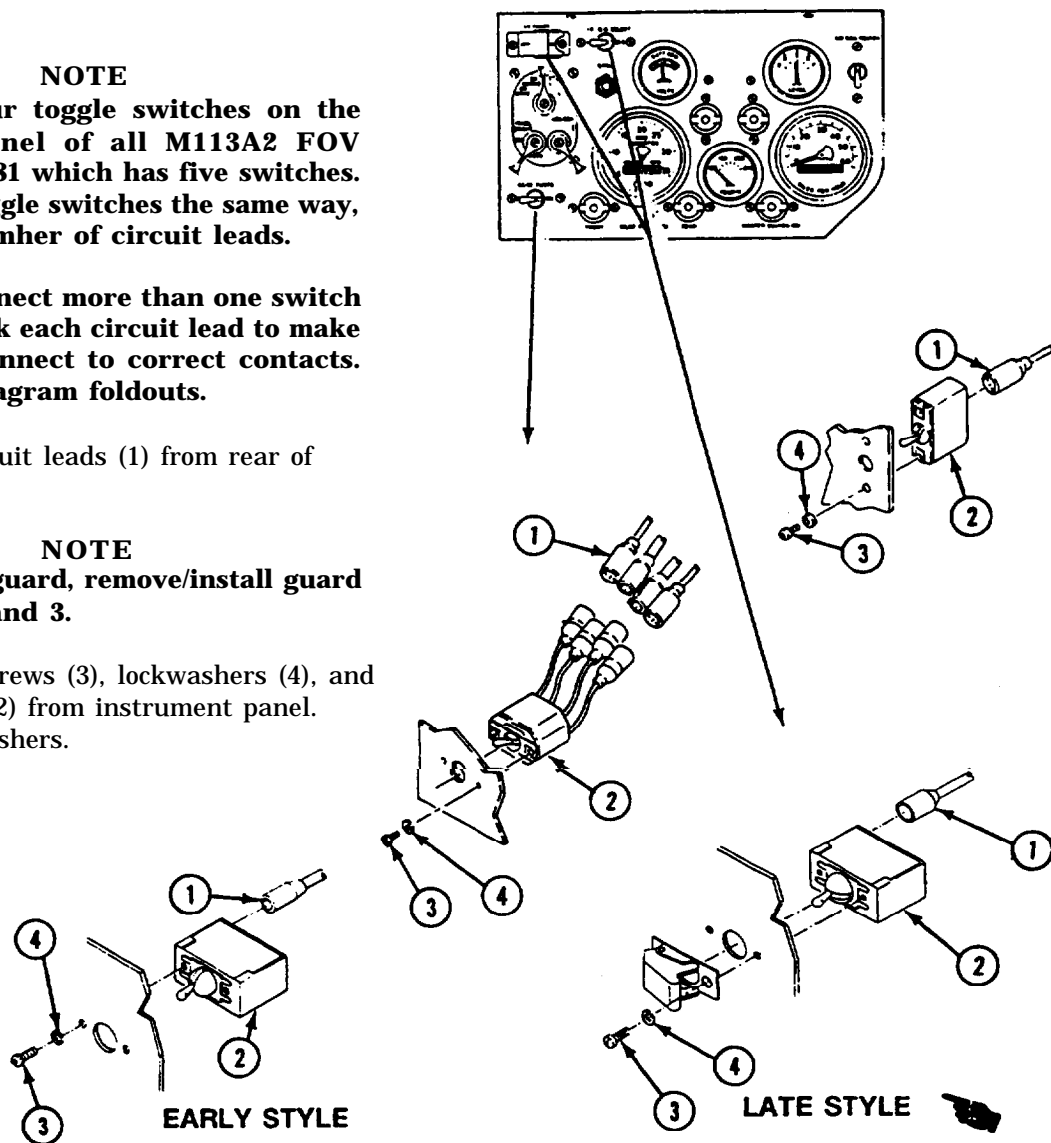

GO TO NEXT PAGE

INSTALL

3. Place toggle switch (1) on rear of instrument panel. Secure with two new lockwashers (2) and screws (3).

NOTE

Make sure circuit leads are connected to correct switches. See wiring diagram foldouts.

4. Connect circuit leads (4) to rear of toggle switch (1).

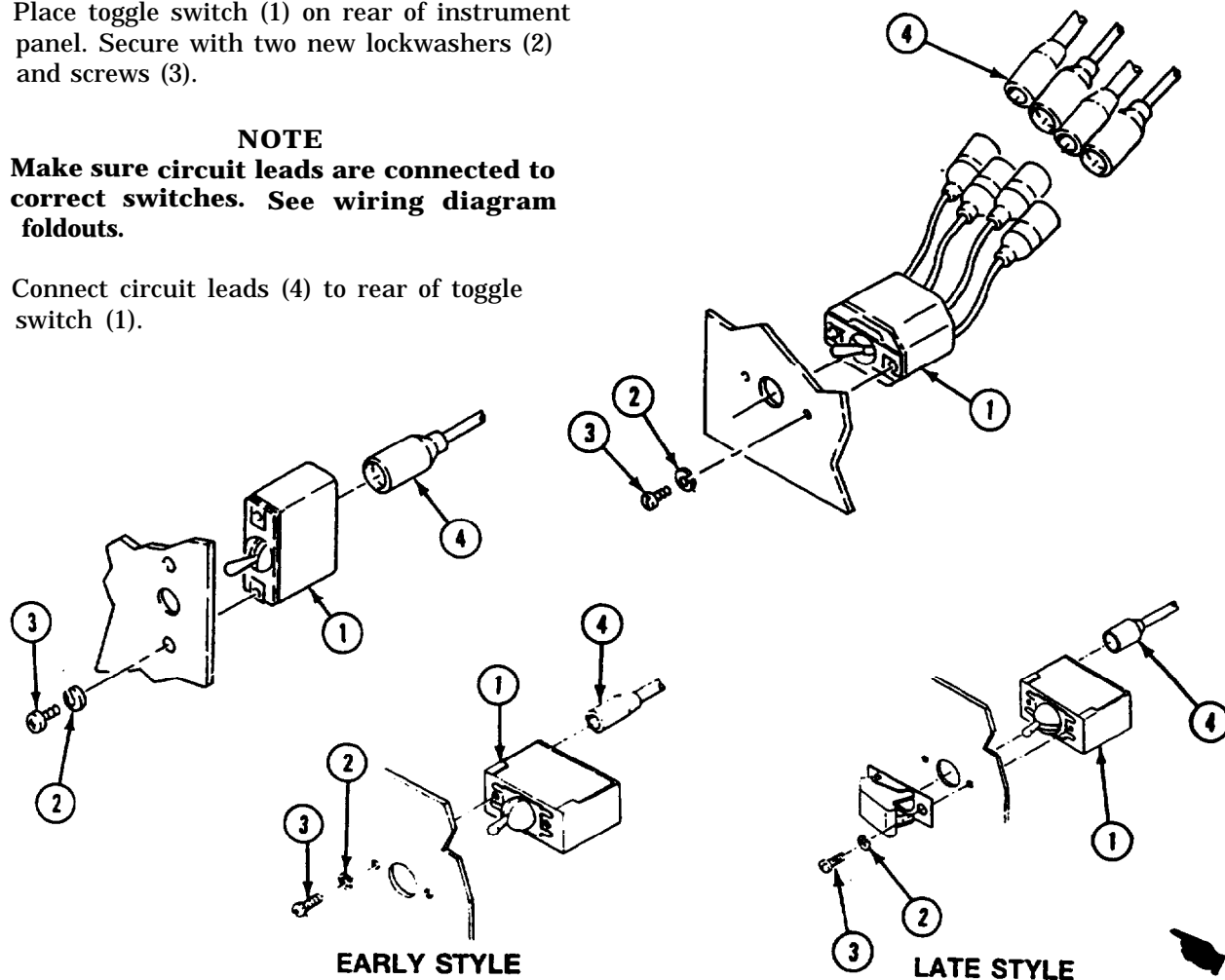

FOLLOW-THROUGH STEPS

1. Connect battery ground lead (page 13-2).
2. Turn MASTER SWITCH ON see your -10).
3. Check for proper operation of switch.
4. Turn MASTER SWITCH OFF (see your -10).

END OF TASK

REPLACE MAIN LIGHT SWITCH

INITIAL SETUP

Tools:

General Mechanics Tool Kit (Item 30, App D)

Personnel Required:

Unit Mechanic

References:

See your -10

Equipment Conditions:

Engine stopped/shutdown (see your -10)

Carrier blocked (see your -10)

Battery ground lead disconnected (page 13-2)

Instrument panel removed (page 11-2)

REMOVE

1. Disconnect cable (1) from main light switch (2).
2. Remove screw (3), washer (4), and switch lever (5) from light switch (2).
3. Remove four screws (6) and light switch (2) from instrument panel.

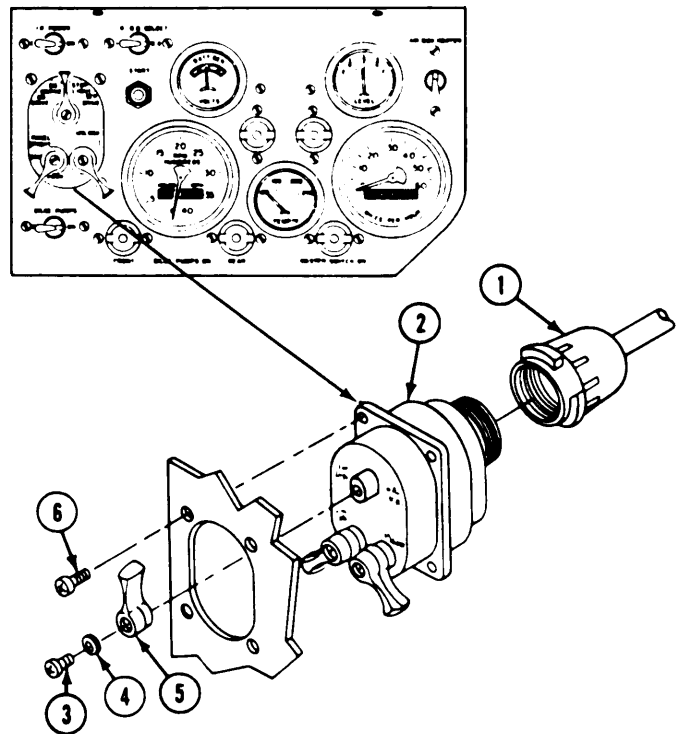

INSTALL

4. Place main light switch (2) in rear of instrument panel. Secure with four screws (6).
5. Place switch lever (5) on light switch (2). Secure with washer (4) and screw (3).
6. Connect cable (1) to rear of light switch (2),

FOLLOW-THROUGH STEPS

1. Install instrument panel (page 13-2).
2. Connect battery ground lead (page 11-2).
3. Turn MASTER SWITCH ON (see your -10).
4. Check for proper operation of switch.
5. Turn MASTER SWITCH OFF (see your -10).

END OF TASK

REPLACE ENGINE START SWITCH

INITIAL SETUP

Tools:

General Mechanics Tool Kit (Item 30, App D)

Materials/Parts:

Lockwasher

Personnel Required:

Unit Mechanic

References:

See your -10

Equipment Conditions:

Engine stopped/shutdown (see your -10)

Carrier blocked (see your -10)

Battery ground lead disconnected (page 13-2)

Instrument panel removed (page 11-2)

REMOVE

1. Remove nut (1) and start switch (2) from instrument panel.
2. Remove lockwasher (3) and nut (4) from start switch (2). Discard lockwasher.
3. Disconnect circuit 14/74 connector (5) from rear of start switch (2).

INSTALL

4. Connect circuit 14/74 connector (5) to rear of start switch (2).
5. Install nut (4) and new lockwasher (3) on start switch (2).
6. Install start switch (2) through rear of instrument panel. Secure with two nuts (1 and 4).

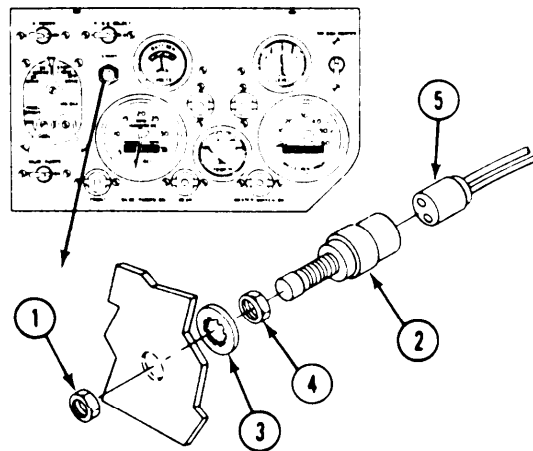

FOLLOW-THROUGH STEPS

1. Install instrument panel (page 11-2).
2. Connect battery ground lead (page 13-2).
3. Turn MASTER SWITCH ON (see your -10).
4. Crank engine to check for proper installation of starter switch (see your -10).
5. Turn MASTER SWITCH OFF (see your -10).

END OF TASK

REPLACE INSTRUMENT PANEL GAGES

DESCRIPTION

This task covers: Remove (page 11-11). Install (page 11-12).

INITIAL SETUP

Tools:

General Mechanics Tool Kit (Item 30, App D)

Materials/Parts:

Lockwasher (2)

Personnel Required:

Unit Mechanic

References:

see your -10

Equipment Conditions:

Engine stopped/shutdown (see your -10)

Carrier blocked (see your -10)

Battery ground lead disconnected (page 13-2)

Instrument panel removed (page 11-2)

REMOVE

NOTE

There are three gages on the instrument panel. Except for the number of leads, remove all gages the same way.

Do not disconnect more than one gage at a time. Mark each lead to make sure you reconnect to correct contacts. See wiring diagram (FO-2).

1. Disconnect circuit leads (1) from rear of gage (2).
2. Remove two nuts (3), lockwashers (4), and bracket (5) from rear of gage (2). Discard lockwashers.
3. Remove gage (2) from front of instrument panel.

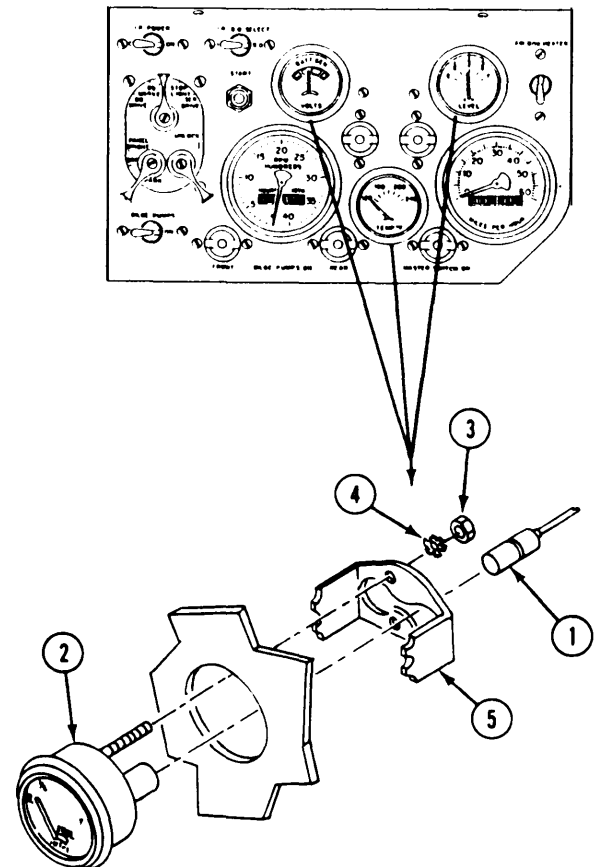

GO TO NEXT PAGE

INSTALL

4. Install gage (1) in front of instrument panel.

NOTE

Check front of instrument panel to make sure gage is aligned correctly before tightening nuts.

5. Install bracket (2) on rear of gage, and secure with two new lockwashers (3) and nuts (4).

CAUTION

Make sure circuit leads are connected to correct gages. See wiring diagram (FO-2).

6. Connect circuit leads (5) to rear of gage (1).

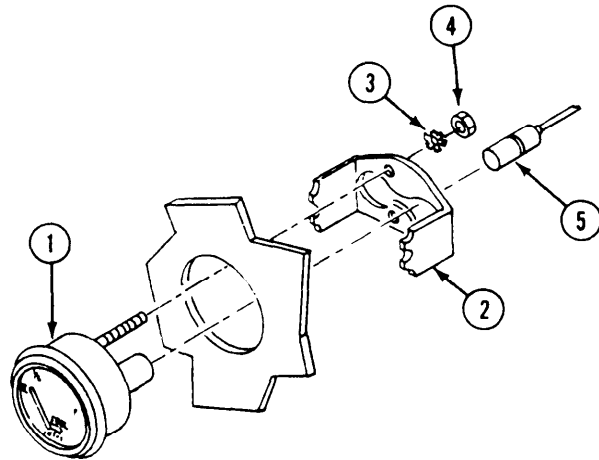

FOLLOW-THROUGH STEPS

1. Install instrument panel (page 11-2).
2. Connect battery ground lead (page 13-2).
3. Turn MASTER SWITCH ON (see your -10).
4. Check fuel gage and battery generator gage for operation (see your -10).
5. Start engine to check operation of coolant temperature gage (see your -10).
6. Stop/shutdown engine (see your -10),

END OF TASK

REPLACE INSTRUMENT PANEL TACHOMETER

INITIAL SETUP

Tools:

General Mechanics Tool Kit (Item 30, App D)

Materials/Parts:

Lockwasher (2)

Personnel Required:

Unit Mechanic

References:

see your-10

Equipment Conditions:

Engine stopped/shutdown (see your -10)

Carrier blocked (see your -10)

Instrument panel removed (page 11-2)

REMOVE

1. Disconnect tachometer cable (1) from rear of tachometer (2)
2. Remove two nuts (3), lockwashers (4), and bracket (5) from rear of tachometer (2). Discard lockwashers.
3. Remove tachometer (2) from front of instrument panel.

6. Connect tachometer cable (1) to rear of tachometer (2).

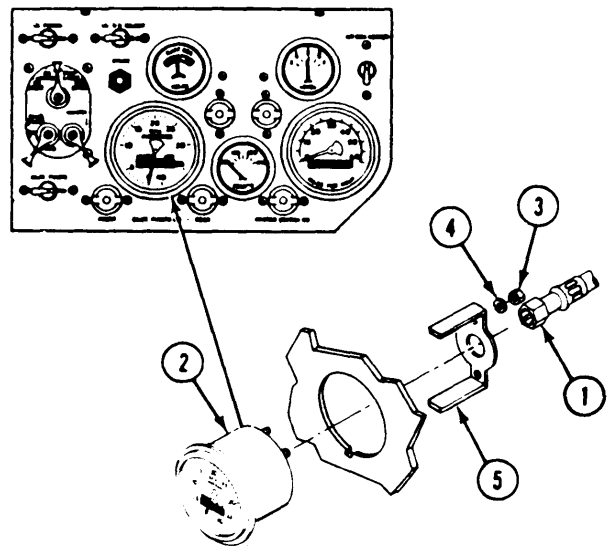

INSTALL

4. Install tachometer (2) in front of instrument panel.
5. Install bracket (5) on rear of tachometer (2) and secure with two new lockwashers (4) and nuts (3).

FOLLOW-THROUGH STEPS

1. Install instrument panel (page 1 1-2).
 2. Start engine (see your -10).
 3. Check tachometer (see your -10).
 4. Stop/shutdown engine (see your -10),
-

END OF TASK

REPLACE TACHOMETER CABLE AND ADAPTER

DESCRIPTION

This task covers: Remove (page 11-14). Install (page 11-15).

INITIAL SETUP

Tools:

General Mechanics Tool Kit (Item 30, App D)

Materials/Parts:

Cable to tachometer gasket
Grommet
Lockwasher (5)
Self-locking nut

Personnel Required:

Unit Mechanic

References:

See your -10
See your -LO

Equipment Conditions:

Engine stopped/shutdown (see your -10)
Carrier blocked (see your -10)
Trim vane lowered and power plant front access door open (see your -1 O)
Driver's power plant access panel removed (page 24-25)
Power plant rear access panel removed (page 24-27 or 24-29)

REMOVE

1. Remove five screws (1), lockwashers (2), and clamps (3) from driver's compartment and power plant compartment bulkhead weldnuts. Discard lockwashers.
2. Remove locknut (4), clamp (5), and screw (6) from clamp (7). Discard locknut.
3. Disconnect tachometer cable (8) from right angle adapter (9) and tachometer (15). Remove cable (8), with clamps and grommet (10) attached, from carrier.
4. Remove grommet (10), gasket (11) from cable (8). Discard grommet and gasket.

5. Pull flexible drive shaft (13) part way out of adapter end of cable (8). Remove slotted washer (14) and flat washer (12) from drive shaft. Remove drive shaft (13) from cable.
6. Loosen nut and remove right angle adapter (9) from engine adapter.
7. Check adapter. Replace adapter that has stripped threads.

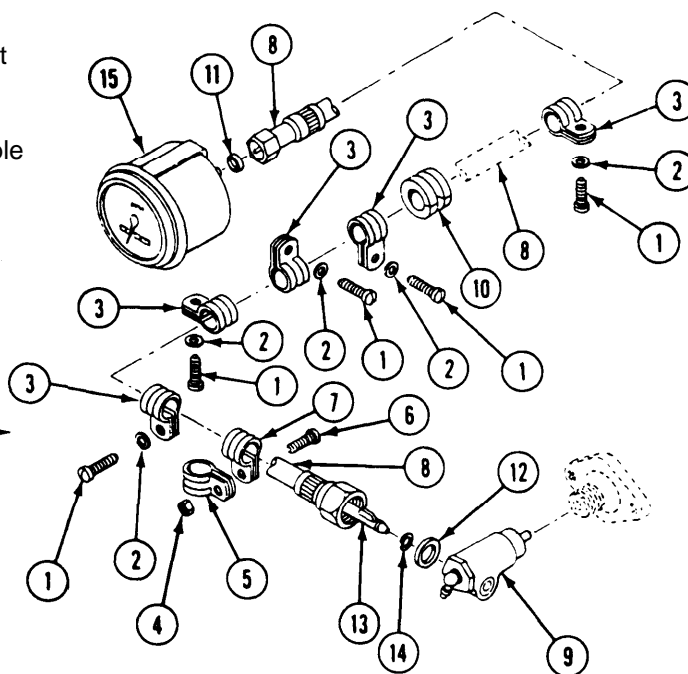
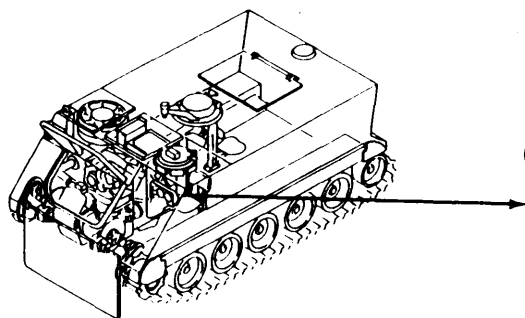

INSTALL

8. Place adapter (1) on engine adapter, and secure with nut.
9. Coat flexible drive shaft (2) with grease and install in cable (3) (see your -LO).

NOTE

Install keyed end of drive shaft (2) in tachometer end of cable (3).

If cable (3) is being replaced, remove all clamps and install them on new cable.

10. Pull drive shaft (2) part way out of adapter end of cable (3), install slotted washer (4) and flat washer (5), on shaft.
11. Install new grommet (6) on cable (3). Route cable through power plant and driver's compartment.

12. Install new gasket (7) in cable. Install cable on tachometer (8) and right angle drive adapter (1).

NOTE

Place cable at tachometer connection as close to carrier wall as possible to minimize bend. All other cables and leads should be in front of the tachometer cable.

13. Align clamp (9) with clamp (10), and secure with screw (11) and new locknut (12).
14. Align seven cable clamps (13) with power plant and driver's compartment bulkhead weldnuts. Secure with seven new lockwashers (14) and screws (15).

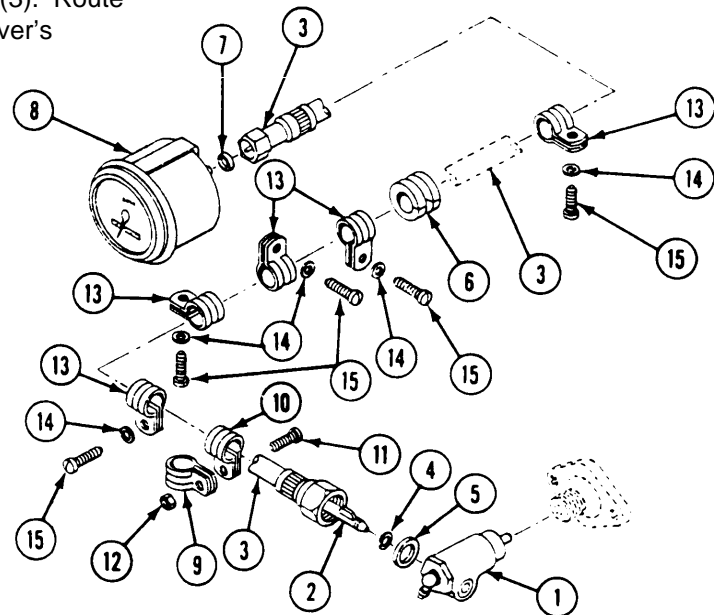

FOLLOW-THROUGH STEPS

1. Install power plant rear access panel (page 24-27 or 24-29).
2. Install driver's power plant access panel (page 24-25).
3. Close power plant front access door and raise trim vane (see your -10).
4. Start engine to check for proper installation of tachometer cable and adapter (see your -10).
5. Stop/shutdown engine (see your -10).

END OF TASK

REPLACE SPEEDOMETER

INITIAL SETUP

Tools:

General Mechanics Tool Kit (Item 30, App D)

Material Parts:

Lockwasher (2)

Personnel Required:

Unit Mechanic

References:

see your -10

Equipment Conditions:

Engine stopped/shutdown (see your -10)

Carrier blocked (see your -10)

REMOVE

1. Disconnect speedometer cable (1) from rear of speedometer (2) by loosening nut (3).
2. Remove two nuts (4), lockwashers (5), and bracket (6) from rear of speedometer (2). Discard lockwashers.
3. Remove speedometer (2) from front of instrument panel.

6. Connect speedometer cable (1) to rear of speedometer (2), and tighten nut (3).

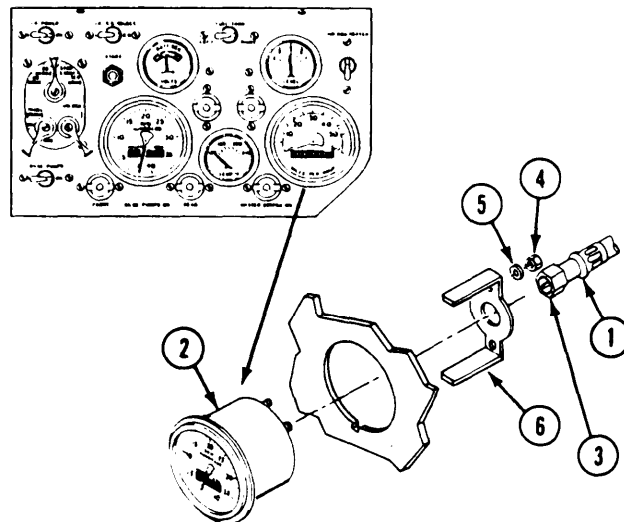

INSTALL

4. Install speedometer (2) in front of instrument panel.
5. Install bracket (6) on rear of speedometer (2) and secure with two new lockwashers (5) and nuts (4).

FOLLOW-THROUGH STEPS

1. Road test carrier (page 2-45) to check for proper installation of speedometer.
2. Stop/shutdown engine (see your -10),

END OF TASK

REPLACE SPEEDOMETER CABLE AND ADAPTER

DESCRIPTION

This task covers: Remove(page 11-17). Install (page 11-18).

INITIAL SETUP

Tools:

General Mechanics Tool Kit (Item 30, App D)

Materials/Parts:

Adapter
Cable
Gasket
Grommet
Key washer (4)
Lockwashers (2)
Preformed packing

Personnel Required:

Unit Mechanic

References:

see your -10
See your -LO

Equipment Conditions:

Engine stopped (see your -10)
Carrier blocked (see your -10)
Trim vane lowered (see your -10)
Power plant front door open (see your -10)
Hull front access cover removed (page 24-24)

REMOVE

1. Remove two screws (1), lockwashers (2), and clamps (3) from bulkhead weldnuts. Discard lockwashers.
2. Disconnect speedometer cable (4) from final drive adapter (5), remove slotted washer (6), and flat washer (7).
3. Remove speedometer (8) from cable (4) with clamps (3) and grommet (9) attached.
4. Remove grommet (9) and gasket (10) from cable (4). Discard grommet and gasket.
5. Straighten four key washers (11). Remove four screws (12), key washers (11), and final drive adapter (5) from final drive. Discard key washers.
6. Remove preformed packing (13) from adapter (5). Discard packing.

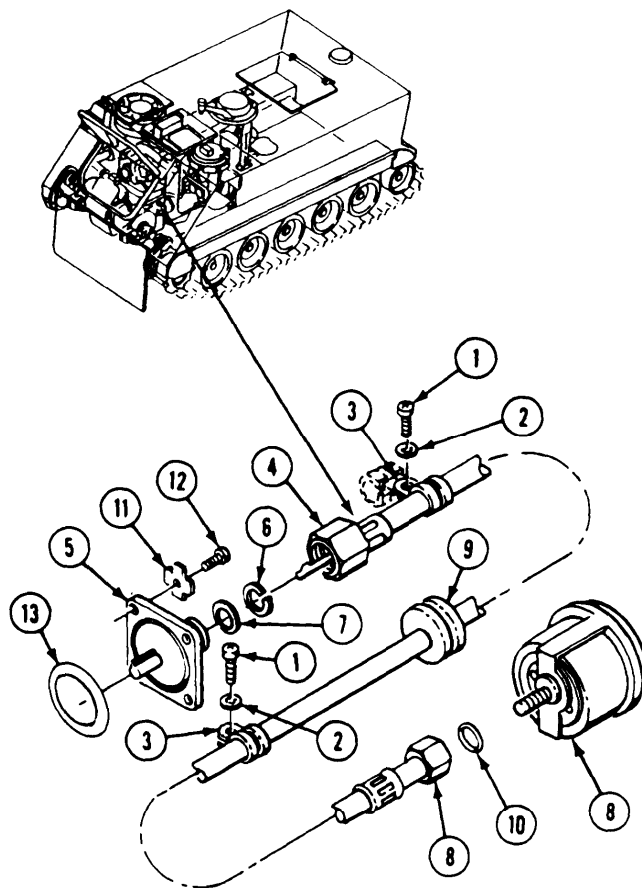

GO TO NEXT PAGE

INSTALL

7. Place new preformed packing (1) on new final drive adapter (2).
8. Grease speedometer shaft (3) (see your -LO).
9. Place adapter (2) on final drive, and secure with four new key washers (4) and screws (5). Bend keys on washers.

NOTE

Remove clamps and install on new cable.

10. Install new grommet (6) on new cable (7), and route cable through driver's compartment bulkhead.
11. Install grommet (6) in bulkhead.
12. Install slotted washer (8), flat washer (9), on speedometer cable (7) to final drive adapter (2).
13. Install speedometer cable (7) with new gasket (10) on speedometer (11).

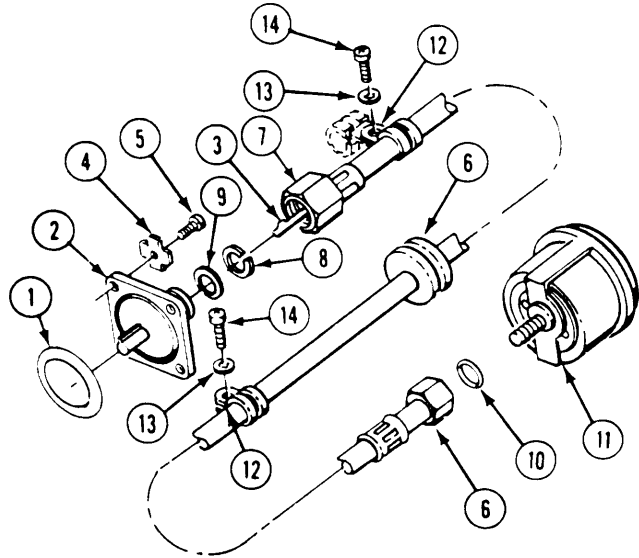

14. Align two clamps (12) with bulkhead weld-nuts and secure with two new lockwashers (13) and screws (14).

FOLLOW-THROUGH STEPS

1. Install hull front access cover (page 24-24).
2. Close power plant front door (see your -10).
3. Raise trim vane (see your -10).

END OF TASK

REPAIR SPEEDOMETER CABLE

INITIAL SETUP

Tools:

General Mechanics Tool Kit (Item 30, App D)

Materials/Parts:

Cable core
Gasket

Personnel Required:

Unit Mechanic

References:

See your -LO

References (cont):

see your -10

Equipment Conditions:

Engine stopped/shutdown (see your -10)
Carrier blocked (see your -10)
Trim vane lowered (see your -10)
Power plant access door open (see your -10)
Hull front access cover removed (page 24-24)
Speedometer cable assembly removed (page 11-17)

REMOVE

1. Remove gasket (1), flat washer (2), slotted washer (3), and cable core (4) from cable housing (5). Discard gasket and cable core.

CLEAN, INSPECT, AND REPAIR

2. Inspect cable housing. If damaged, replace complete cable assembly (page 11-17).

INSTALL

3. Coat cable core (4) with grease (see your -LO).
4. Push new cable core (4) into cable housing (5).
5. Install new gasket (1), and flat washer (2) in cable housing (5).
6. Install slotted washer (3) on cable core (4) at final drive adapter end.

7. Connect speedometer cable to final drive adapter and speedometer (page 11-17).

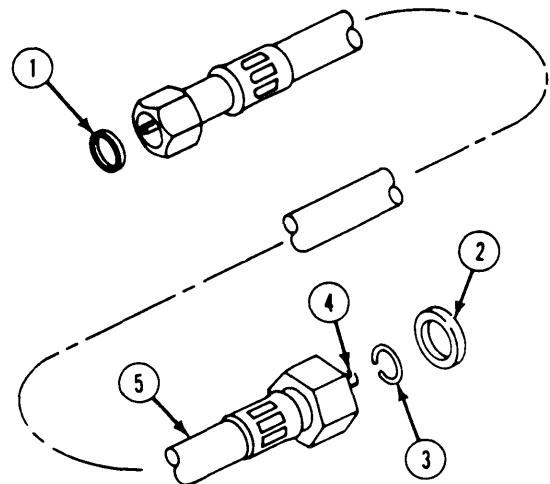

FOLLOW-THROUGH STEPS

1. Install speedometer cable assembly (page 11-17).
2. Install hull front access cover (page 24-24).
3. Close power plant access door (see your -10).
4. Raise trim vane (see your -10). END OF TASK

END OF TASK

REPLACE FUEL SELECT SWITCH TO GAGE LEAD (M981 AND M1064 ONLY)

INITIAL SETUP

Tools:

- General Mechanics Tool Kit (Item 30, App D)
- Digital Multimeter (Item 43, App D)

Personnel Required:

- Unit Mechanic

References:

- See Your -10

Equipment Conditions:

- Engine shutdown (see your -10)
- Carrier blocked (see your -10)
- Battery ground leads disconnected (page 13-2)
- Instrument panel partially removed (page 11-2)

REMOVE

1. Disconnect circuit 28 lead (1) from fuel select switch (2).
2. Disconnect circuit 28 lead (1) from fuel gage (3). Remove lead.

CLEAN, INSPECT, AND REPAIR

3. Check lead for continuity. Use multimeter. Replace bad lead.
4. Check lead and connectors. Look for worn or frayed lead and damaged connectors. Repair bad parts (page 14-1).

INSTALL

5. Connect circuit 28 lead (1) to fuel gage (3).
6. Connect circuit 28 lead (1) to fuel select switch (2).

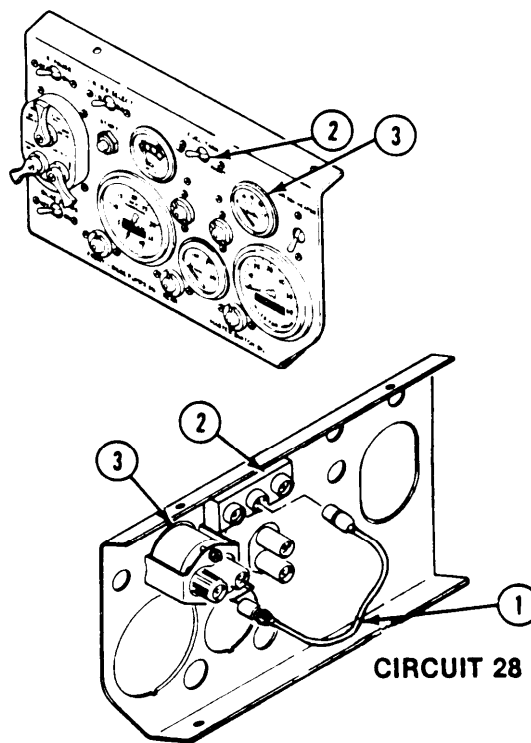

FOLLOW-THROUGH STEPS

1. Install instrument panel (page 11-2).
2. Connect battery ground leads (page 13-2).
3. Turn MASTER OR BATTERY SWITCH ON (see your -10).
4. Look for fuel gage movement to check for proper installation of fuel select switch to fuel gage lead.
5. Turn MASTER OR BATTERY SWITCH OFF (see your -10).

END OF TASK

Section II. WARNING LIGHT PANEL

TASK INDEX

<u>Task</u>	<u>Page</u>	<u>Task</u>	<u>Page</u>
Replace Warning Panel Lights	11-22	Replace Warning Light Panel Assembly	11-25
Replace Horn Switch	11-24	Replace Warning Light Panel	11-26

REPLACE WARNING PANEL LIGHTS

DESCRIPTION

This task covers: Remove (page 11-22). Clean, Inspect, Repair (page 11-23).
Install (page 11-23).

INITIAL SETUP

Tools:

General Mechanics Tool Kit (Item 31, App D)

References:

See your -10

Materials/Parts:

Light bulbs, as needed
Lockwasher (2)

Equipment Conditions:

Engine stopped/shutdown (see your -10)
Carrier blocked (see your -10)

Personnel Required:

Unit Mechanic

REMOVE

NOTE

There are four lights on warning light panel. Remove all lights the same way.

1. Remove light bulb (1).
 - a. Turn lens (2) to the left. Remove lens and gasket (3) from light assembly (4).
 - b. Push in and turn light bulb (1) to the left and remove bulb from light assembly (4).
2. Remove light assembly (4).

NOTE

Do not disconnect more than one light at a time. Mark each lead to make sure you reconnect to correct contacts. See wiring diagram (FO-2).

- a. Disconnect circuit lead (5) from light assembly (4).
- b. Remove two screws (6), lockwashers (7), and light assembly (4) from warning lights panel. Discard lockwashers.

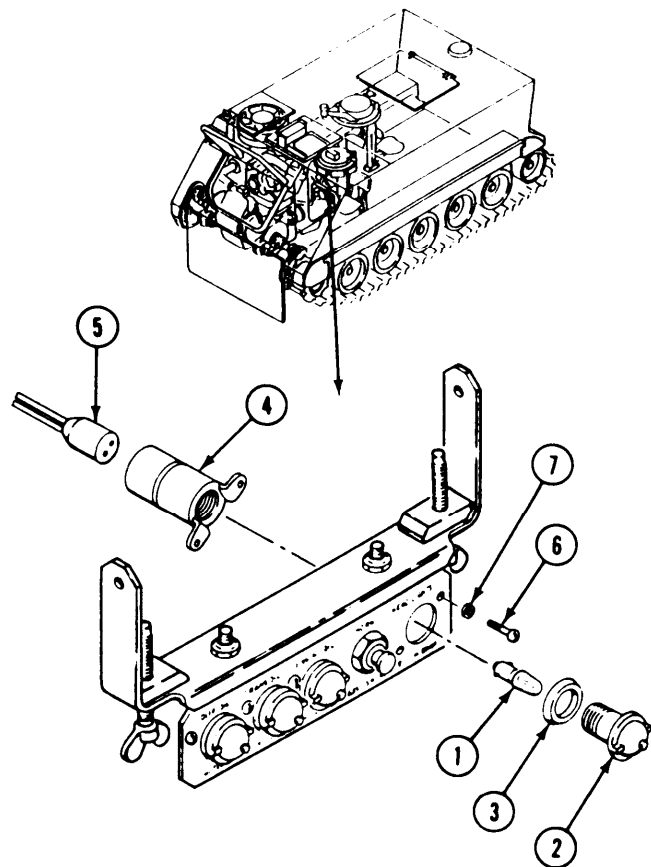

CLEAN, INSPECT, AND REPAIR

3. Check light bulb. Replace bad light bulb.
4. Check light assembly. Replace bad light assembly.

INSTALL

5. Install light assembly (1).
 - a. Place light assembly (1) on rear of warning light panel. Secure with two new lockwashers (2) and screws (3).

CAUTION

Make sure circuit leads are connected to correct lights. See wiring diagram (FO-2).

- b. Connect circuit lead (4) to light assembly (1).
6. Install light bulb (5).
 - a. Install light bulb (5) in light assembly (1). Push and turn light bulb to the right to secure.
 - b. Install gasket (6) and lens (7) in light assembly (1). Turn lens to the right to secure.

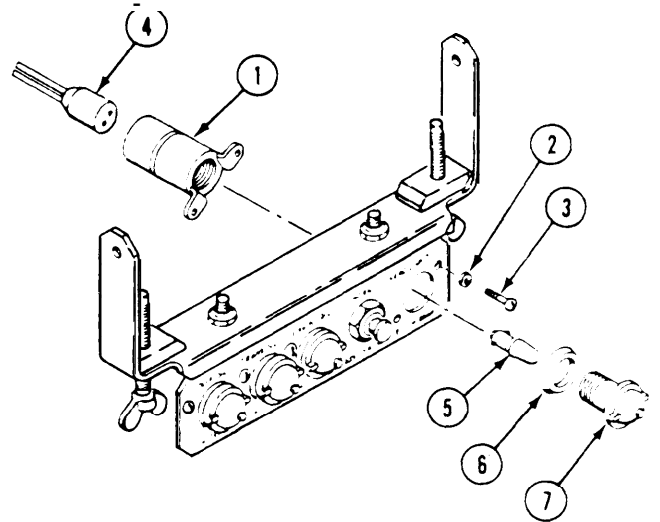

FOLLOW-THROUGH STEPS

1. Turn MASTER SWITCH ON (see your -10).
2. Check differential oil high temperature warning light. It should be OFF. It will come on when you ground circuit 328 lead.
3. Check engine low oil pressure indicator. It should be ON.
4. Check transmission high oil temperature indicator. It should be OFF. It will come on when you ground circuit lead 327.
5. Turn MASTER SWITCH OFF (see your -10).

END OF TASK

REPLACE HORN SWITCH

INITIAL SETUP

Tools:

General Mechanics Tool Kit (Item 30, App D)

References:

See your-10

Personnel Required:

Unit Mechanic

Equipment conditions:

Engine stopped/shutdown (see your -10)
Carrier blocked (see your -10)

NOTE

Two nuts and lockwashers come with new switch.

8. Connect circuit 25/25A connector (1) to rear of horn switch (2).

REMOVE

1. Disconnect circuit 25/25A connector (1) from rear of horn switch (2).
2. Remove nut (3) and horn switch (2) from warning light panel.
3. Remove suspension lockout light bracket (4) from horn switch (2) (M741A1 only).
4. Remove lockwasher (5) and nut (6) from horn switch (2). Discard lockwasher,

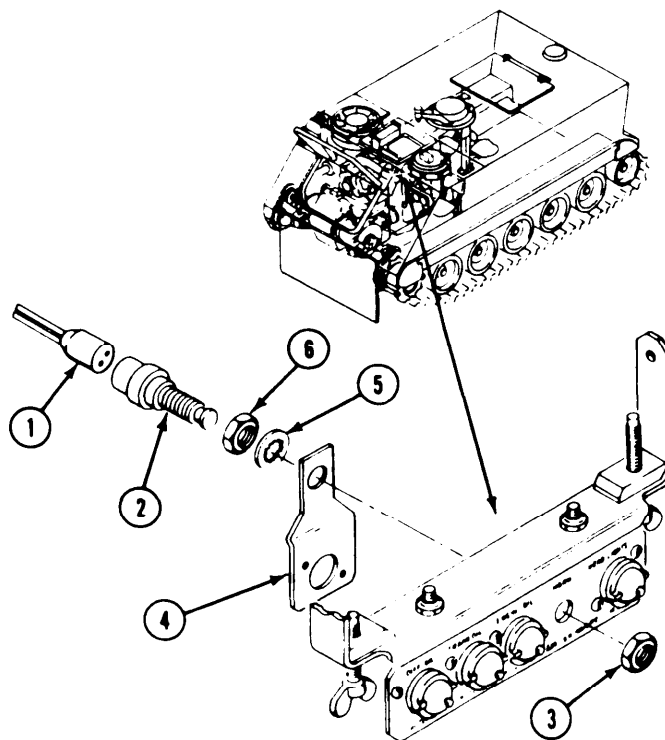

INSTALL

5. Install nut (6) and new lockwasher (5) on horn switch (2).
6. Install bracket (4) on horn switch (2) (M741A1 only).
7. Install horn switch through rear of warning light panel. Secure with nut (3).

FOLLOW-THROUGH STEPS

1. Turn MASTER SWITCH ON (see your -10).
2. Press horn switch to check for proper installation.
3. Turn MASTER SWITCH OFF (see your -10).

END OF TASK

REPLACE WARNING LIGHT PANEL ASSEMBLY

INITIAL SETUP

Tools:

General Mechanics Tool Kit (Item 30, App D)

Materials/Parts:

Cotter pin (2)

Personnel Required:

Unit Mechanic

References:

see your -10

Equipment Conditions:

Engine stopped/shutdown (see your -10)

Carrier blocked (see your -10)

Horn switch removed (page 11-24)

Warning panel lights removed (page 11-22)

REMOVE

- 1, Remove five connectors (1) from warning light panel (2).
- 2, Remove two cotter pins (3), straight pins (4), washers (5), and panel (2) with mount bracket (6) from hull mounts (7). Discard cotter pins.

INSTALL

3. Position mount bracket (6) on hull mounts (7). Secure with two straight pins (4), washers (5), and new cotter pins (3).

NOTE

Be sure to connect leads to their correct lights. See wiring diagram (FO-2).

4. Install five connectors (1) on rear of panel (2).

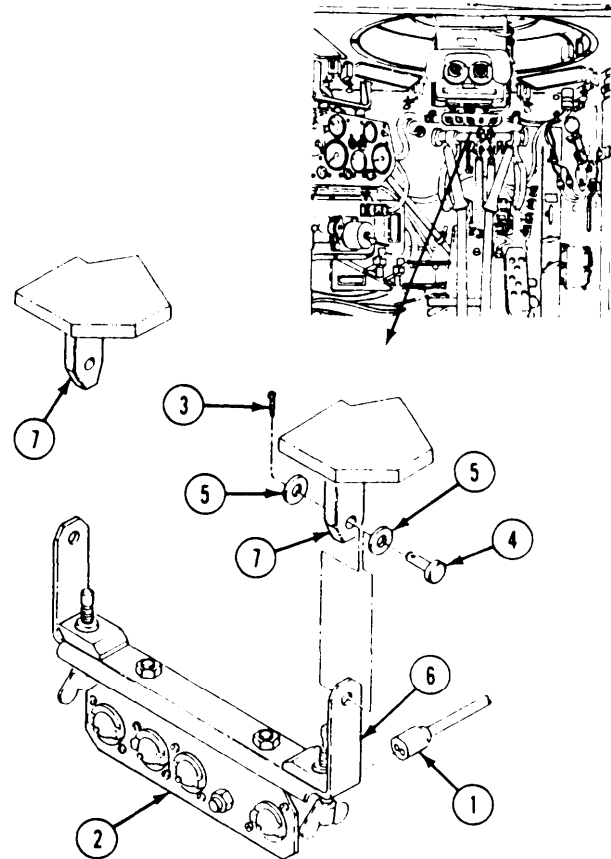

FOLLOW-THROUGH STEPS

1. Install horn switch (page 11-24),
 2. Install warning panel lights (page 11-22).
-

END OF TASK

REPLACE WARNING LIGHT PANEL

INITIAL SETUP

Tools:

General Mechanics Tool Kit (Item 30, App D)

References:

See your -10

Materials/Parts:

Self-locking nut (2)

Equipment Conditions:

Engine stopped/shutdown (see your -10)

Carrier blocked (see your -10)

Panel warning lights removed (page 11-22)

Horn switch removed (page 11-24)

Personnel Required:

Unit Mechanic

REMOVE

1. Remove two locknuts (1), screws (2), washers (3), and four mounts (4), from panel (5) and bracket (6). Remove panel from bracket. Discard locknuts.

INSTALL

2. Install four mounts (4) and panel (5) on bracket (6). Secure with two washers (3), screws (2), and new locknuts (1).

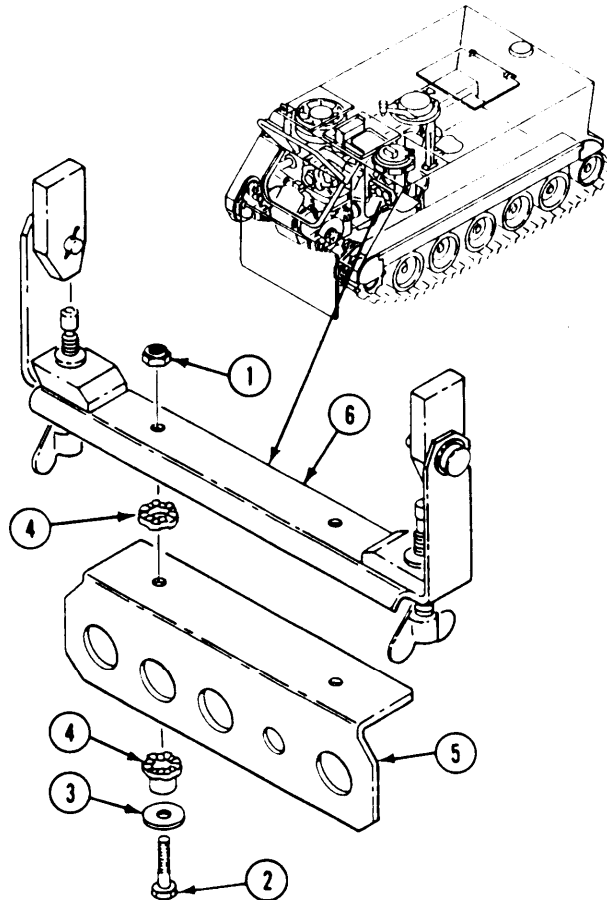

FOLLOW-THROUGH STEPS

1. Install horn switch (page 11-24).
 2. Install panel warning lights (page 11-22).
-

END OF TASK

CHAPTER 12
ELECTRICAL SYSTEM MAINTENANCE — HORN AND LIGHTING
SYSTEM

section I. HORN AND EXTERIOR LIGHTS

TASK INDEX

<u>Task</u>	<u>Page</u>	<u>Task</u>	<u>Page</u>
Replace Horn and Ground Lead	12-2	Replace Blackout Headlight	12-9
Replace Service and Infrared Headlights	12-3	Repair Blackout Headlight	12-10
Repair Semite and Infrared Headlights	12-5	Replace Headlight Guard	12-11
Replace Blackout Marker Light	12-7	Replace Left Stop Light-Tail Light	12-12
Repair Blackout Marker Light	12-8	Repair Left/Right Stop Light-Tail Light	12-13
		Replace Right Stop Light-Tail Light	12-14

REPLACE HORN AND GROUND LEAD

INITIAL SETUP

Tools:

General Mechanics Tool Kit (Item 30, App D)

Materials/Parts:

Lockwasher (2)
 Lockwasher
 Self-locking nut

Personnel Required:

Unit Mechanic

References:

See your -10

Equipment Conditions:

Engine stopped/shutdown (see your -10)
 Carrier blocked (see your -10)

REMOVE

1. Disconnect ground lead (1) and circuit 25 lead (2) from horn (3).
2. Remove two screws (4), lockwashers (5), and horn (3) from hull bracket (6). Discard lockwashers.
3. Remove locknut (7), lockwasher (8), ground lead (1), washer (9), and screw (10) from bracket (6). Discard lockwasher and locknut.

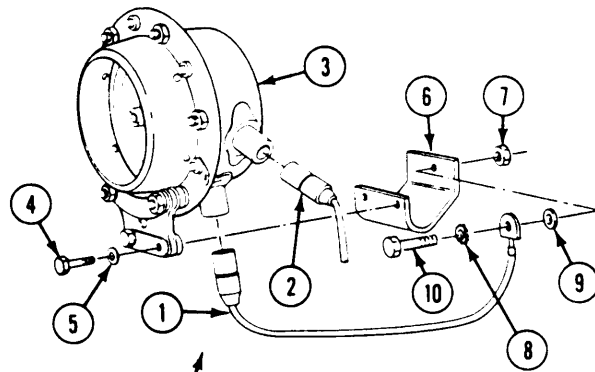

INSTALL

4. Install ground lead (1) on bracket (6). Secure with screw (10), washer (9), new lockwasher (8), and new locknut (7).
5. Install horn (3) on bracket (6). Secure with two new lockwashers (5) and screws (4).
6. Connect circuit 25 lead (2) and ground lead (1) to horn (3).

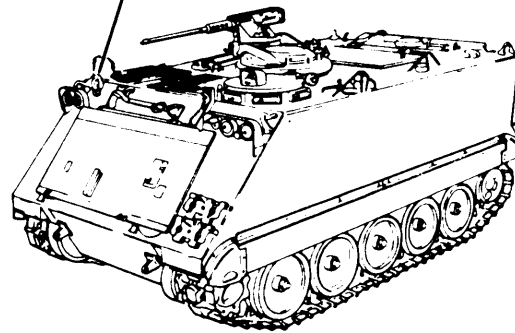

FOLLOW-THROUGH STEPS

1. Turn MASTER SWITCH ON (see your -10). Press horn button to check that horn works.
2. Turn MASTER SWITCH OFF (see your -10).

END OF TASK

REPLACE SERVICE AND INFRARED HEADLIGHTS

DESCRIPTION

This task covers: Remove (page 12-3). Install (page 12-4).

INITIAL SETUP

Tools:

General Mechanics Tool Kit (Item 30, App D)

Materials/parts:

Lockwasher

Personnel Required:

Unit Mechanic

References:

see your -10

Equipment Condition:

Engine stopped/shutdown (see your -10)

Carrier blocked (see your -10)

REMOVE

NOTE

Remove and install service headlight and infrared headlight the same way, except for circuit leads.

1. Disconnect circuit 17 lead (1) and circuit 18 lead (2) from rear of service headlight (3).
2. Disconnect circuit 514 lead (1) and circuit 515 lead (2) from rear of infrared headlight (3).
3. Remove nut (4), lockwasher (5), small bevel washer (6), large bevel washer (7), and headlight (3) from hull bracket. Discard lockwasher.

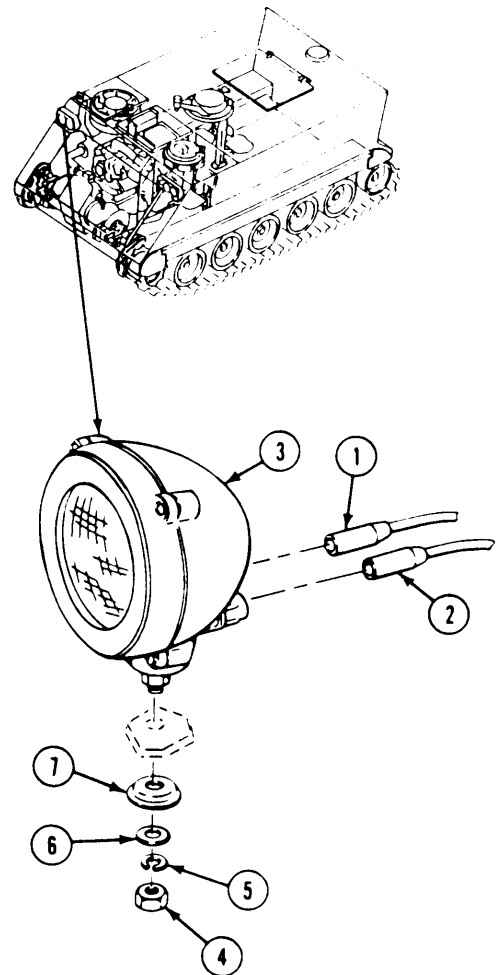

GO TO NEXT PAGE

INSTALL

4. Place headlight (1) and large bevel washer (2) on hull bracket. Secure with small bevel washer (3), new lockwasher (4), and nut (5).
5. Connect circuit 18 lead (6) and circuit 17 lead (7) to rear of service headlight (1).
6. Connect circuit 515 lead (6) and circuit 514 lead (7) to rear of infrared headlight(1).

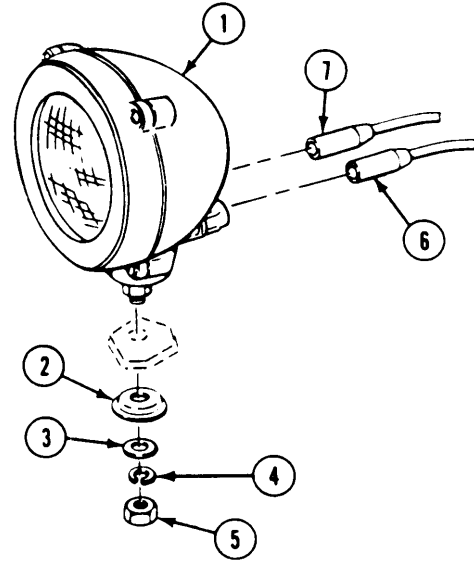

FOLLOW-THROUGH STEPS

1. Turn MASTER SWITCH ON (see your -10).
2. Turn on service headlights to check that they operate properly (see your -10).
3. Turn infrared headlights on (see your -10) and hold hand near lens, Heat means headlight is working.
4. Turn all switches OFF on instrument panel (see your -10).
5. Turn MASTER SWITCH OFF (see your -10).

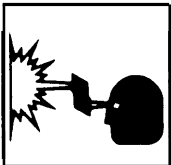

WARNING
Do not look directly into infrared headlights. You may damage your eyes.

END OF TASK

REPAIR SERVICE AND INFRARED HEADLIGHTS

DESCRIPTION

This task covers: Remove (page 12-5). Clean. Inspect. and Repair (page 12-6),
Install (page 12-6).

INITIAL SETUP

Tools:

General Mechanics Tool Kit (Item 30, App D)

References:

See your -10

Materials/Parts

Gasket
Lockwasher
Preformed packing
Preformed packing

Equipment Conditions:

Engine stopped/shutdown (see your -10)
Carrier blocked (see your -10)
Service and/or infrared headlight removed
(page 12-3)

Personnel Required:

Unit Mechanic

NOTE

Repair of service headlight and infrared headlight is the same. Service headlight has clear lens and infrared headlight has dark red lens.

REMOVE

- Loosen four screws (1). Remove door (2) and preformed packing (3) from headlight body (4). Discard packing.
- Loosen four screws (5). Remove retainer plate (6), lens (7), and gasket (8) from door (2). Discard gasket.

- Loosen three screws (9). Remove retainer plate (10) from body (4). Pull lamp unit (11) from body. Disconnect lamp unit from plug.
- Remove four screws (12), resilient mount (13), and preformed packing (14) from body (4). Discard preformed packing.
- Remove screw (15) and lockwasher (16) from mount (13). Discard lockwasher.

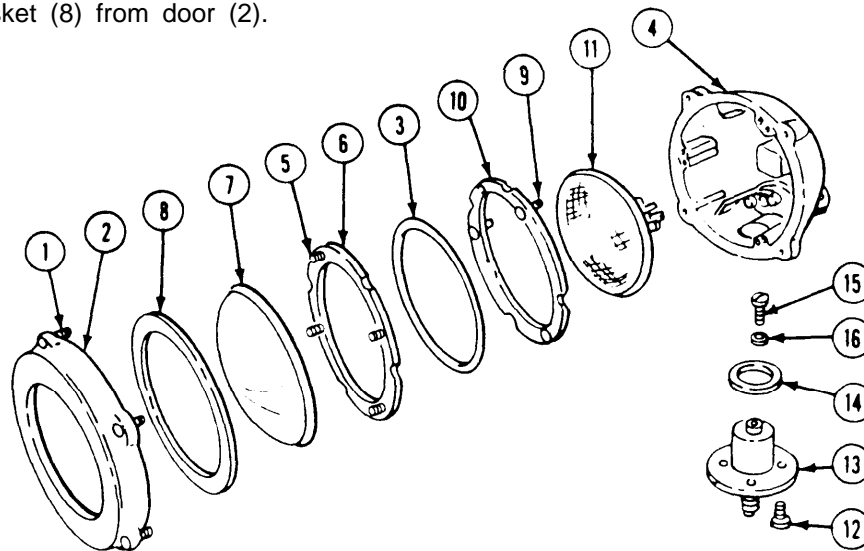

GO TO NEXT PAGE

CLEAN, INSPECT, AND REPAIR

- 6. Check lens. Replace cracked or chipped lens.
- 7. Check lamp unit. See troubleshooting (page 3-93). Replace bad lamp unit.
- 8. Check door, body, and retainer plates. Replace headlight if any part is missing or damaged (page 12-3).

INSTALL

- 9. Install new lockwasher (1) and screw (2) in mount (3).

CAUTION

Use care when tightening four mount screws (5). Do not overtighten. Overtightening the screws will strip the housing threads.

- 10. Install new preformed packing (4), resilient mount (3), and four screws (5) in body (6).
- 11. Connect lamp unit (7) to plug in lamp body (6) with word FOG at the bottom.
- 12. Install lamp unit (7), retainer plate (8), and three screws (9) in body (6).
- 13. Install new gasket (10), lens (11), retainer plate (12), and four screws (13) in door (14).
- 14. Install new preformed packing (15), door (14), and four screws (16) on body (6).

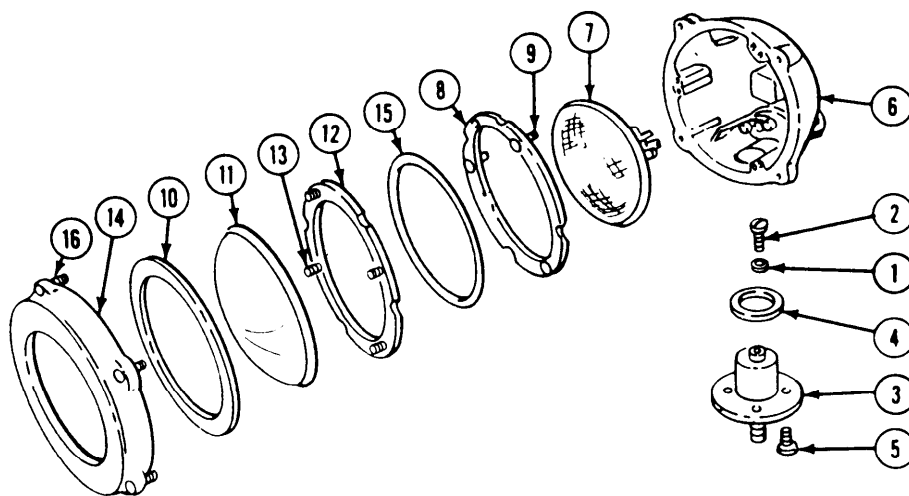

FOLLOW-THROUGH STEPS

- 1. Install service and/or infrared headlight (page 12-3).

END OF TASK

REPLACE BLACKOUT MARKER LIGHT

INITIAL SETUP

Tools:

General Mechanics Tool Kit (Item 30, App D)

Materials/Parts:

Lockwasher
Self-locking nut

Personnel Required:

Unit Mechanic

References:

see your -10

Equipment Conditions:

Engine stopped/shutdown (see your -10)
Carrier blocked (see your -10)

REMOVE

1. Disconnect circuit 20 lead (1) from rear of blackout marker light (2).
2. Remove locknut (3), washer (4), lockwasher (5), and marker light (2) from hull bracket. Discard lockwasher and locknut.

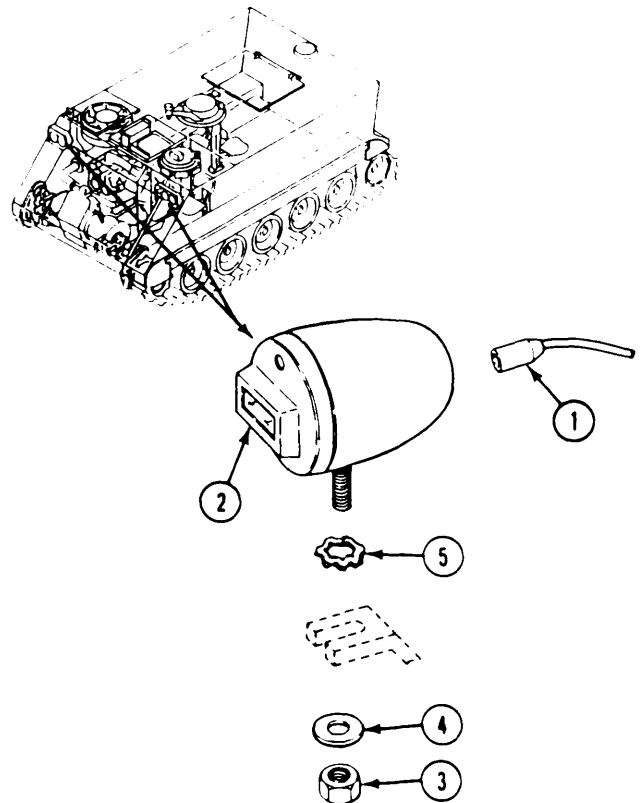

INSTALL

3. Install blackout marker light (2), new lockwasher (5), washer (4), and new locknut (3) on hull bracket,
4. Connect circuit 20 lead (1) to rear of marker light (2).

FOLLOW-THROUGH STEPS

1. Turn MASTER SWITCH ON (see your -10).
2. Turn blackout marker light switch on to check that light is operable (see your -10).
3. Turn all switches OFF on instrument panel (see your -10).
4. Turn MASTER SWITCH OFF (see your -10).

END OF TASK

REPAIR BLACKOUT MARKER LIGHT

INITIAL SETUP

Tools:

General Mechanics Tool Kit (Item 30, App D)
Multimeter (Item 43, App D)

References:

See your-10

Materials/Parts:

Gasket
Light bulb, as needed

Equipment Conditions:

Engine stopped/shutdown (see your -10)
Carrier blocked (see your -10)

Personnel Required:

Unit Mechanic

REMOVE

1. Loosen two screws (1). Remove door (2) and gasket (3) from light body (4). Discard gasket.
2. Push in on bulb (5) and turn to the left. Remove bulb from body (4).

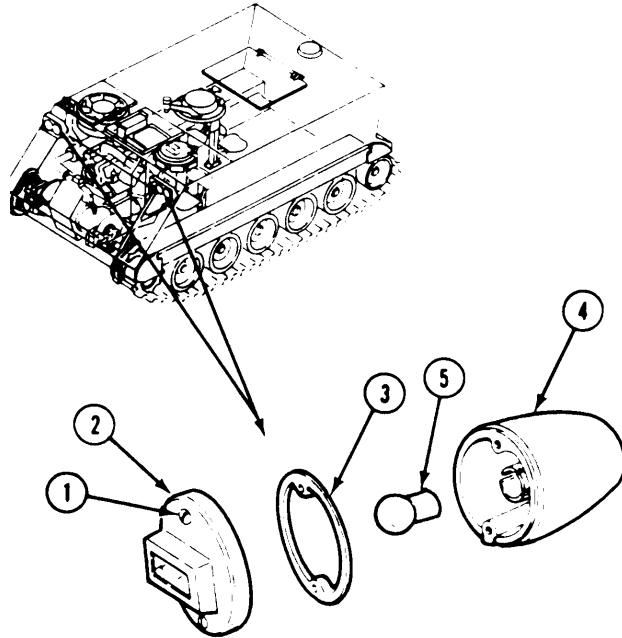

CLEAN, INSPECT, AND REPAIR

3. Check lens in door. Replace blackout marker door assembly if lens is cracked or chipped.
4. Check bulb. Use multimeter. Replace bad bulb.
5. Check body. Replace blackout marker light if any part is missing or damaged (page 12-7).

INSTALL

6. Place bulb (5) in light body (4). Push in on bulb and turn to the right to secure.
7. Install new gasket (3), door (2), and two screws (1) on body (4).

FOLLOW-THROUGH STEPS

1. Turn MASTER SWITCH ON (see your -10).
 2. Turn blackout marker light switch ON to check that light operates properly (see your -10).
 3. Turn all switches OFF on instrument panel (see your -10).
 4. Turn MASTER SWITCH OFF (see your -10).
-

END OF TASK

REPLACE BLACKOUT HEADLIGHT

INITIAL SETUP

Tools:

General Mechanics Tool Kit (Item 30, App D)

Materials/Parts:

Lockwasher

Personnel Required:

Unit Mechanic

References:

see your -10

Equipment Conditions:

Engine stopped/shutdown (see your -10)
Carrier blocked (see your -10)

REMOVE

1. Disconnect circuit 19 lead (1) from rear of blackout headlight (2).
2. Remove nut (3), lockwasher (4), finishing washer (5), and blackout headlight (2) from hull bracket. Discard lockwasher.

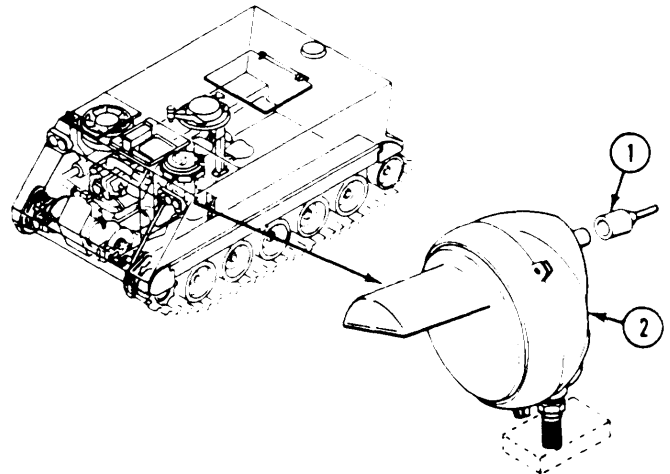

CLEAN, INSPECT, AND REPAIR

3. Check lead and connector. Replace frayed, broken, or cracked parts (page 14-1).

INSTALL

4. Install blackout headlight (2), finishing washer (5), new lockwasher (4), and nut (3) on hull bracket.
5. Connect circuit 19 lead (1) to rear of blackout headlight (2),

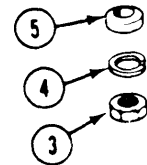

FOLLOW-THROUGH STEPS

1. Turn MASTER SWITCH ON (see your -10).
2. Turn blackout headlight switch ON to check that headlight operates properly (see your -10).
3. Turn all switches OFF (see your -10).

END OF TASK

REPAIR BLACKOUT HEADLIGHT

INITIAL SETUP

Tools:

General Mechanics Tool Kit (Item 30, App D)

Materials/Parts:

Lamp unit
Retaining clip (3)

Personnel Required:

Unit Mechanic

References:

See your -10

Equipment Conditions:

Engine stopped/shutdown (see your -10)
Carrier blocked (see your -10)

REMOVE

1. Loosen three screws (1). Pull retainer (2) with lamp unit (3) away from light housing (4).
2. Disconnect ground lead (5) and positive lead (7) from housing (4).
3. Remove three retaining clips (6) and lamp

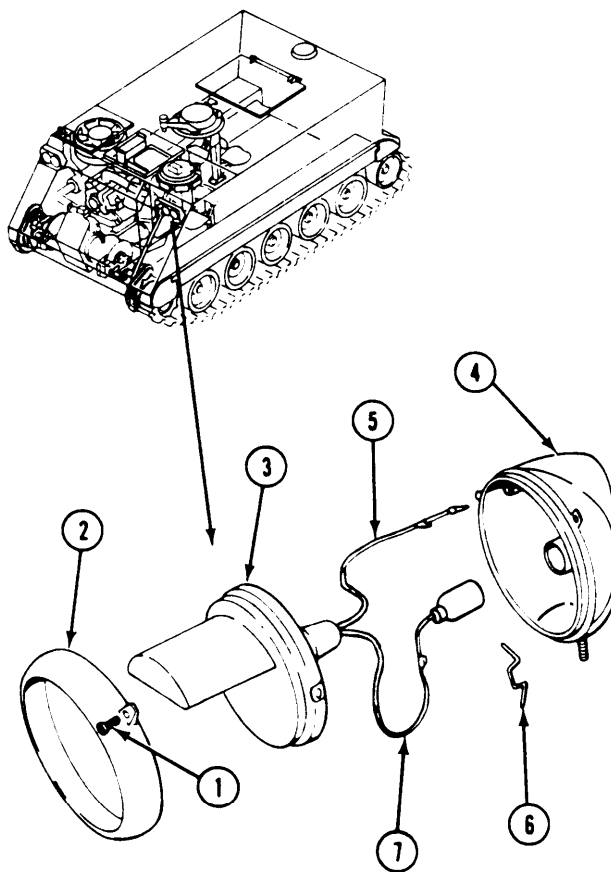

CLEAN, INSPECT, AND REPAIR

4. Check retainer and housing, replace blackout headlight if any part is missing or damaged (page 12-7).

INSTALL

5. Install new lamp unit (3) in retainer (2). Secure with three new retaining clips (6).
 6. Connect positive lead (7) and ground lead (5) to light housing (4).
 7. Install retainer (2) with lamp unit (3) and three screws (1) on housing (4).
-

FOLLOW-THROUGH STEPS

1. Turn MASTER SWITCH ON (see your -10).
 2. Turn blackout headlight switch ON to check that headlight operates properly (see your -10).
 3. Turn all switches OFF (see your -10).
-

END OF TASK

REPLACE HEADLIGHT GUARD

INITIAL SETUP

Tools:

General Mechanics Tool Kit (Item 30, App D)

Materials/Parts:

Self-locking nut (8)

Personnel Required:

Unit Mechanic

References:

see your -10

Equipment Conditions:

Engine stopped/shutdown (see your -10)
Carrier blocked (see your -10)

REMOVE

NOTE

Procedures to remove and install headlight guard is the same for right and left sides of the vehicle.

1. Remove four locknuts (1), washers (2), screws (3), and headlight guard (4) from hull mount. Discard locknuts.

INSTALL

2. Install headlight guard (4), four washers (2), screws (3), and new locknuts (1) on hull mount.

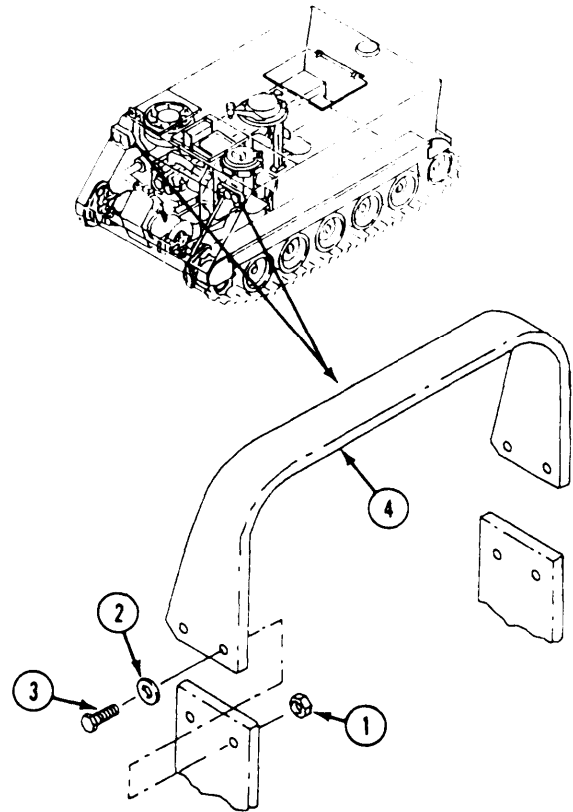

END OF TASK

REPLACE LEFT STOP LIGHT-TAIL LIGHT

INITIAL SETUP

Tools:

General Mechanics Tool Kit (Item 30, App D)

References:

See your -10

Materials/Parts:

Gasket
Lockwasher (6)

Equipment Conditions:

Engine stopped/shutdown (see your -10)
Battery ground lead disconnected (page 13-2)
Carrier blocked (see your -10)

Personnel Required:

Unit Mechanic

REMOVE

1. Remove four screws (1) and lockwashers (2). Pull guard (3), with stop light-tail light (4) attached, away from hull. Discard lockwashers,
2. Disconnect circuit 21 lead (5), circuit 22 lead (6), and circuit 24 lead (7) from tail light leads (8).
3. Remove two screws (9), lockwashers (10), tail
Discard gasket and lockwashers.

NOTE
M577A21 does not have items (1), (2), or (3).

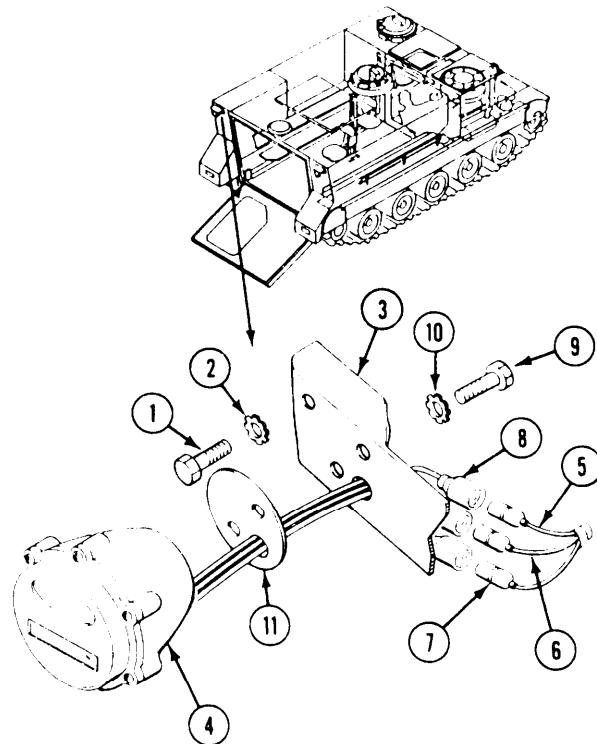

INSTALL

4. Place new gasket (11) and tail light (4) on guard (3). Secure with two new lockwashers (10) and screws (9).
5. Connect circuit 24 lead (7), circuit 22 lead (6), and circuit 21 lead (5) to tail light leads (8).
6. Place guard (3), with tail light (4) attached, on hull. Secure with four new lockwashers (2) and screws (1).

FOLLOW-THROUGH STEPS

1. Connect battery ground lead (page 13-2).
 2. Turn MASTER SWITCH ON. Operate main light switches to check that left stop light-tail light is operable. Turn all switches OFF (see your -10).
-

END OF TASK

REPAIR LEFT/RIGHT STOP LIGHT-TAIL LIGHT

INITIAL SETUP

Tools:

General Mechanics Tool Kit (Item 30, App D)

Materials/Parts:

Preformed packing

Personnel Required:

Unit Mechanic

References:

See your -10

Equipment Conditions:

Engine stopped/shutdown (see your -10)

Carrier blocked (see your -10)

REMOVE

1. Loosen six screws (1). Remove retainer (2) from light housing (3).
2. Remove preformed packing (4) from retainer (2). Discard packing.
3. Push in on two small bulbs (5) and one large bulb (6). Turn each bulb to the left and remove from light housing (3).
6. Place new preformed packing (4) on retainer (2).
7. Place retainer (2) on light housing (3). Secure with six screws (1).

CLEAN, INSPECT AND REPAIR

4. Check retainer and housing, replace stop light-tail light if any part is missing or damaged (page 12-12).

INSTALL

5. Install two small bulbs (5) and one large bulb (6) in light housing (3). Push in and turn to the right to secure.

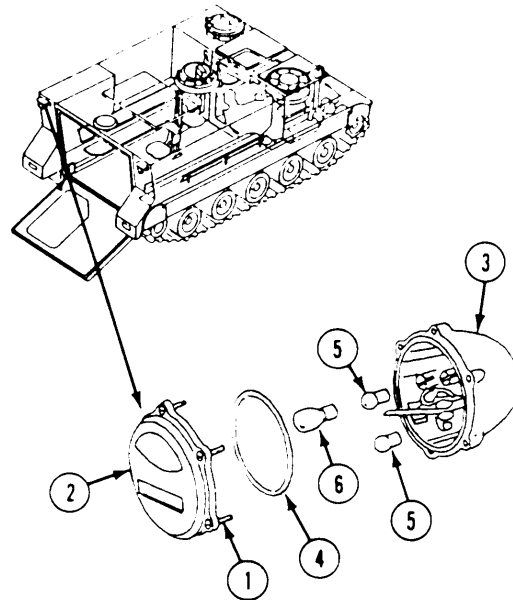

FOLLOW-THROUGH STEPS

1. Connect battery ground lead (page 13-2).
2. Turn MASTER SWITCH ON. Operate main light switches to check that left/right stop light-tail light is operable. Turn all switches OFF (see your -10).

END OF TASK

REPLACE RIGHT STOP LIGHT-TAIL LIGHT

INITIAL SETUP

Tools:

General Mechanics Tool Kit (Item 30, App D)

Materials/Parts:

Gasket
Lockwasher (2)

Personnel Required:

Unit Mechanic

References:

See your -10

Equipment Conditions:

Engine stopped/shutdown (see your -10)
Battery ground lead disconnected (page 13-2)
Carrier blocked (see your -10)

REMOVE

1. Disconnect circuit 23 lead (1) and circuit 24 lead (2) from stop light-tail light leads (3).
2. Remove two nuts (4), two lockwashers (S), stop light-tail light (5), and gasket (6) from carrier hull. Discard gasket and lockwashers.
3. If needed, remove two studs (7) from rear of stop light-tail light (5).

INSTALL

4. If removed, install two studs (7) in rear of stop light-tail light (5).
5. Place new gasket (6) and stop light-tail light (5) on carrier hull. Secure with two new lockwashers (8), and two nuts (4).
6. Connect circuit 24 lead (2) and circuit 23 lead (1) to stop light-tail light leads (3).

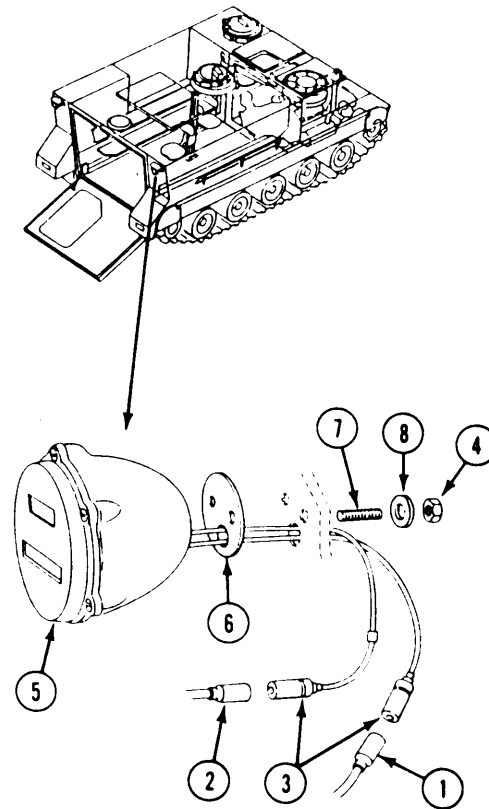

FOLLOW-THROUGH STEPS

1. Connect battery ground lead (page 13-2).
2. Turn MASTER SWITCH ON. Operate main light switches to check that right stop light-tail light is operable. Turn all switches OFF (see your -10).

END OF TASK

**Section II. MAINTENANCE OF WIRING HARNESS
(M741A1 ONLY)**

TASK INDEX

<u>Task</u>	<u>Page</u>	<u>Task</u>	<u>Page</u>
Replace Right Service Tail Light Wiring Harness (M741A1 only)	12-16	Replace Trailer Light Receptacle Wiring Harness (M741A1 only)	12-18
Replace Left Rear Turn Signal Wiring Harness (M741A1 only)	12-17	Replace Right Rear Turn Signal Wiring Harness (M741A1 only)	12-20

REPLACE RIGHT SERVICE TAIL LIGHT WIRING HARNESS (M741A1 ONLY)

INITIAL SETUP

Tools:

General Mechanics Tool Kit (Item 30, App D)

Material/Parts:

Strap (6)

Personnel Required:

Unit Mechanic

References:

See your -10

Equipment Conditions:

Engine stopped (see your -10)

Ramp lowered (see your -10)

Battery ground lead disconnected (page 13-2)

Carrier blocked (see your -10)

Rear floor plates removed (page 24-40)

REMOVE

1. Disconnect circuit 24 leads (1) at trailer receptacle wiring harness, main wiring harness, and right stop light-tail light.
2. Cut straps (2) that secure wiring harness (3) to the main harness. Remove harness. Discard straps.

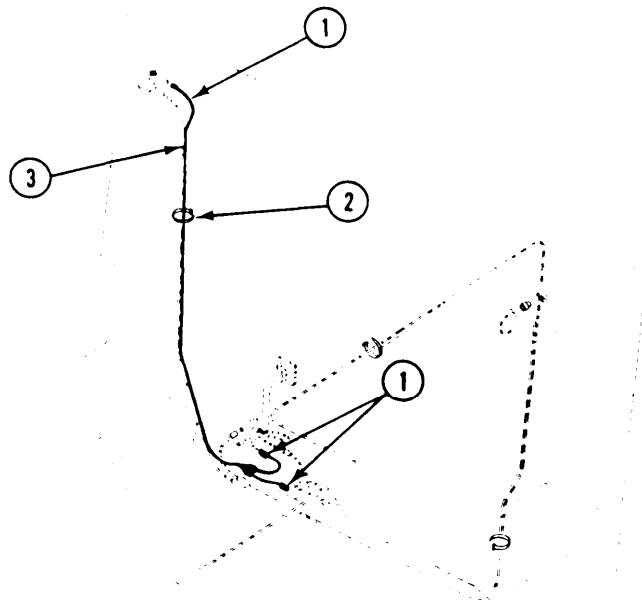

INSTALL

3. Route wiring harness (3) from center rear along carrier main harness. Secure to main harness with new straps (2).
4. Connect circuit 24 leads (1) at trailer receptacle harness, right stop light-tail light, and rear main harness.

FOLLOW-THROUGH STEPS

1. Connect battery ground lead (page 13-2).
 2. Turn MASTER SWITCH ON. Operate stop light-tail lights and turn signals. Check that all lights operate properly. Turn all light switches OFF.
 3. Install rear floor plates (page 2440).
 4. Raise and lock ramp (see your -10).
 5. Stop engine (see your -10).
-

END OF TASK

REPLACE LEFT REAR TURN SIGNAL WIRING HARNESS (M741A1 ONLY)

INITIAL SETUP

Tools:

General Mechanics Tool Kit (Item 30, App D)

Materials/Parts:

Straps (6)

Personnel Required:

Unit Mechanic

References:

See your -10

Equipment Conditions:

Engine stopped (see your -10)
Carrier blocked (see your -10)
Ramp lowered (see your -10)
Battery ground lead disconnected (page 13-2)
Rear floor plates removed (page 24-40)

REMOVE

1. Remove two screws (1), washers (2), and guard (3) that secure wiring harness (4) to hull.
2. Cut straps (5) that secure harness (4) to main wiring harness. Discard straps.
3. Disconnect circuit 23 leads (6) at trailer receptacle, left stop light-tail light, and main harness. Remove harness.

6. Connect circuit 23 leads (6) at left stop light-tail light, trailer receptacle, and main harness.

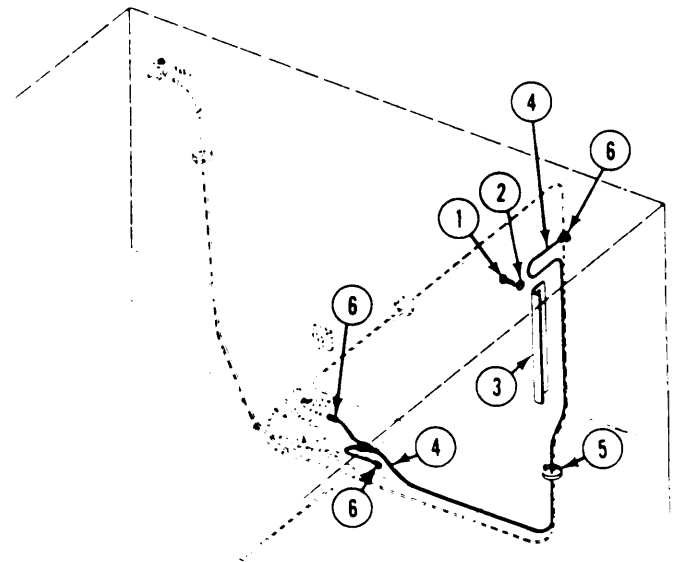

INSTALL

4. Route wiring harness (4) from center rear along carrier main wiring harness to upper left of carrier. Secure harness to the carrier main harness with new straps (5).
5. Position guard (3) and secure with two screws (1) and washers (2).

FOLLOW-THROUGH STEPS

1. Connect battery ground lead (page 13-2).
2. Turn MASTER SWITCH ON. Operate stop light-tail lights and turn signals. Check that all lights operate properly. Turn all light switches OFF (see your -10).
3. Install rear floor plates (page 24-40).
4. Raise and lock ramp (see your -10).
5. Stop engine (see your -10).

END OF TASK

REPLACE TRAILER LIGHT RECEPTACLE WIRING HARNESS (M741A1 ONLY)

DESCRIPTION

This task covers: Remove (page 12-18). Install (page 12-19).

INITIAL SETUP

Tools:

General Mechanics Tool Kit (Item 30, App D)

References:

See your -10

Materials/Parts:

Gasket

Equipment Conditions:

- Ramp lowered (see your -10)
- Engine stopped (see your -10)
- Carrier blocked (see your -10)
- Battery ground lead disconnected (page 13-2)
- Rear floor plates removed (page 24-40)

Personnel Required:

Unit Mechanic

REMOVE

1. Remove four screws (1) that secure receptacle and cover (2).
2. Remove screw (3), two washers (4), and clamp (5) that secure ground lead (6).
3. Disconnect circuit 21, 23, 24, and 22-460-461 leads.

4. Remove four shells (7) and washers (8) from wiring harness (9).
5. Remove nut (10) and connector (11) from hull exterior.
6. Pull harness (9) through hull. Remove spring (12) from harness (9).
7. Remove nut (13) from elbow (14) and pull harness (9) from ramp. Discard gasket (15).
8. Remove elbow (14) from bottom of ramp.

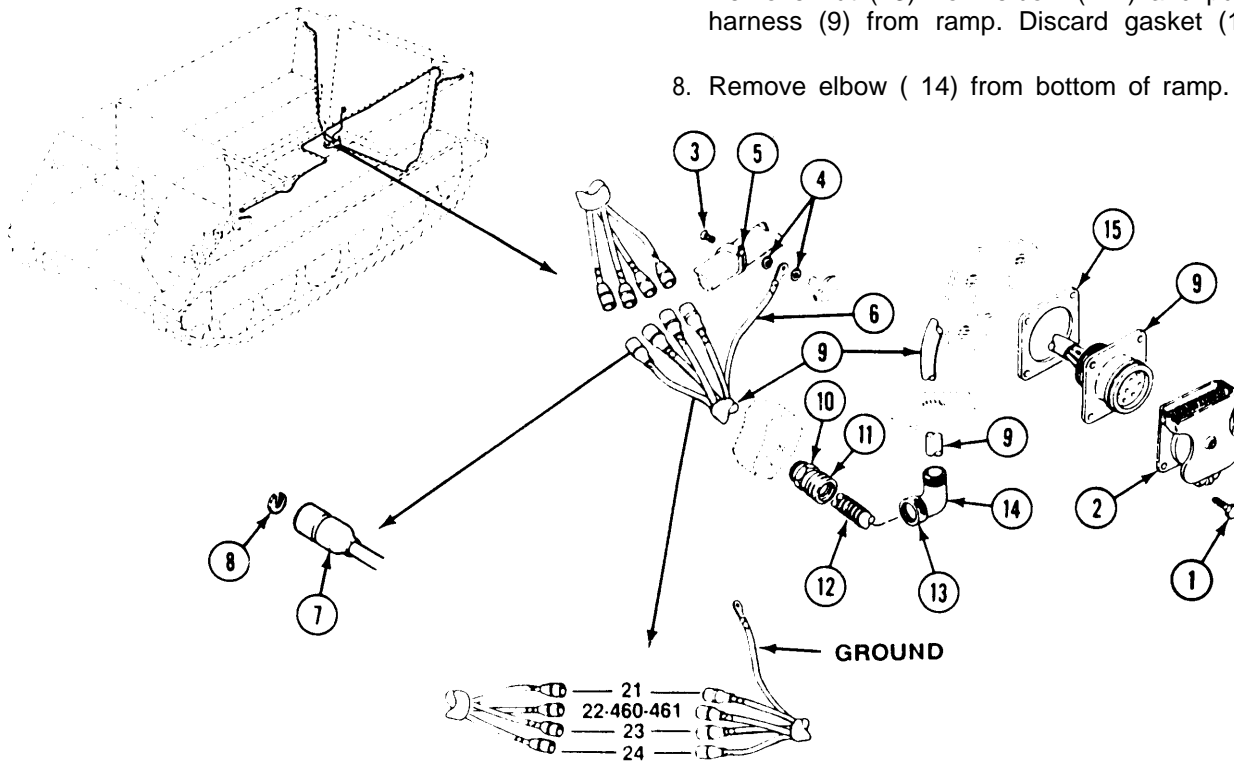

INSTALL

9. Install new gasket (1) on wiring harness (2). Feed through two holes in ramp.
10. Feed harness (2) through elbow (3), Install elbow (3) in bottom of ramp.
11. Install nut (4), spring (5), nut (6), and connector (7) on harness (2). Feed harness through hull.
12. Install receptacle and cover (8). Secure with four screws (9).
13. Install four shells (10) and washers (11) on leads of harness (2).
14. Position ground lead (12) and clamp (13). Secure with two washers (14) and screw (15).
15. Connect circuits 21, 23, 24, and 22-460-461 leads.

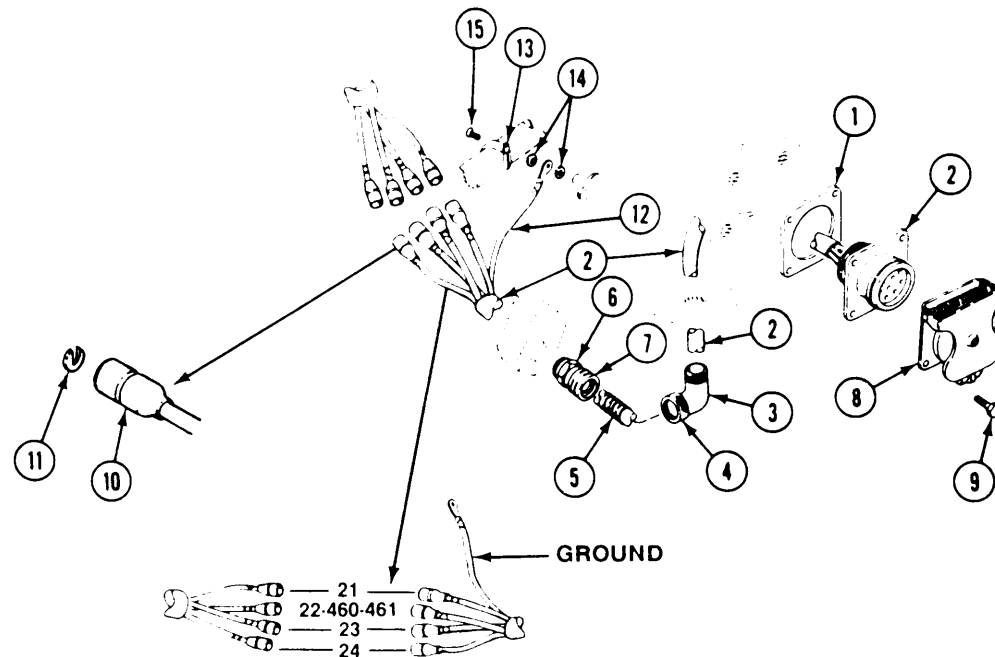
**FOLLOW-THROUGH STEPS**

1. Connect battery ground lead (page 13-2).
2. Turn MASTER SWITCH ON. Operate stop light-tail lights and turn signals. Check that all lights are operable. Turn all light switches OFF (See your -10).
3. Install rear floor plates (page 24-40).
4. Raise and lock ramp (see your -10).
5. Stop engine (see your -10).

END OF TASK

REPLACE RIGHT REAR TURN SIGNAL WIRING HARNESS (M741A1 ONLY)

DESCRIPTION

This task covers: Remove (page 12-20). Install (page 12-21).

INITIAL SETUP

Tools:

General Mechanics Tool Kit (Item 30, App D)

References:

See your -10

Materials/Parts:

Strap (12)

Equipment Conditions:

Ramp lowered (see your -10)

Engine stopped (see your -10)

Carrier blocked (see your -10)

Battery ground lead disconnected (page 13-2)

Rear floor plates removed (page 24-40)

Personnel Required:

Unit Mechanic

REMOVE

1. Cut straps (1) that secure wiring harness (2) to main wiring harness. Discard straps,
2. Disconnect circuit 22-460 leads (3) from harness (2) above instrument panel.

3. Disconnect circuit 22-460 leads (4) from right stop light-tail light and trailer receptacle. Remove circuit 22--460 wiring harness (2) from carrier.

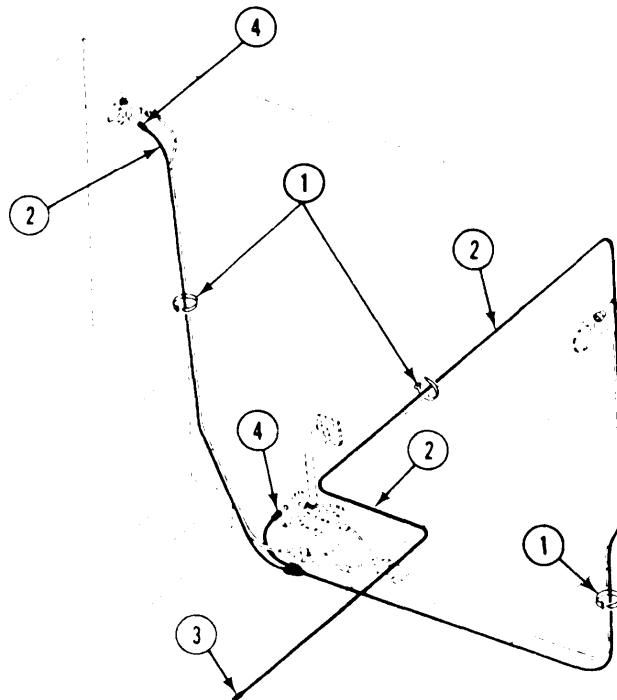

INSTALL

1. Route wiring harness (1) along carrier main wiring harness to center rear and upper right rear of carrier. Secure harness (1) to main harness with new straps (2).
2. Connect circuit 22-460 leads (3) to harness (1) and turn signal control wiring harness above instrument panel.
3. Connect circuit 22-460 leads (4) to right stop light-tail light and to trailer receptacle.

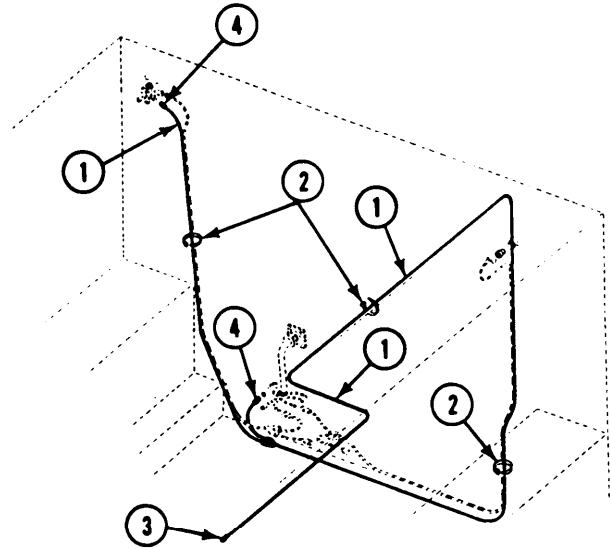

FOLLOW-THROUGH STEPS

- | | |
|---|--|
| <ol style="list-style-type: none"> 1. Connect battery ground lead (Page 13-2). 2. Turn MASTER SWITCH ON. Operate stop light-tail lights and turn signals. Check that all lights operate properly. Turn all light switches OFF (see your -10). | <ol style="list-style-type: none"> 3. Install rear floor plates (Page 24-40). 4. Raise and lock ramp (see your -10). 5. stop engine (see your -10). |
|---|--|

END OF TASK

Section III. MAINTENANCE OF DISTRIBUTION BOX

TASK INDEX

<u>Task</u>	<u>Page</u>	<u>Task</u>	<u>Page</u>
Replace Distribution Box Assembly for 200 AMP Generator System (M577A2 and M1068 Only)	12-23	Replace Distribution Box Assembly for 100 AMP Generator System (M741A1 (Only)	12-40
Replace Distribution Box Assembly for 100 AMP Generator System (M577M Only)	12-28	Replace Distribution Box Assembly for 100 AMP Generator System (M113A2, M106A2, M125A2, M1064, and M1059 Only)	12-44
Replace Distribution Box Assembly for 100 AMP Generator System (M901A1 Only)	12-32	Replace Distribution Box Assembly for 200 AMP Generator System (M113A2, M106A2, M1064, and M125A2 Only)	12-48
Replace Distribution Box Assembly for 200 AMP Generator System (M741A1 Only)	12-36	Replace Distribution Box Assembly for 200 AMP Generator System (M901A1 Only)	12-52

REPLACE DISTRIBUTION BOX ASSEMBLY FOR 200 AMP GENERATOR SYSTEM (M577A2 AND M1068 ONLY)

DESCRIPTION

This task covers: Remove (page 12-23). Install (page 12-25).

INITIAL SETUP

Tools:

General Mechanics Tool Kit (Item 30, App D)

References.

see your -10

Materials/Parts:

Sealing compound (Item 52, App C)
Gasket
Grommet (9)
Lockwasher (5)
Lockwasher (5)

Equipment Conditions:

Engine stopped (see your -10)
Carrier blocked (see your -10)
Battery ground lead disconnected (page 13-2)
Master switch panel assembly removed (page 9-22)

Personnel Required:

Unit Mechanic

REMOVE

1. Remove screw (1), lockwasher (2), and circuit 415 lead (3) from bus bar (4). Remove circuit 415 lead and grommet (5) from distribution box (6). Discard grommet and lockwasher.
2. Remove screw (7), lockwasher (8), circuit 6 lead (9), and circuit 49 lead (10) from bus bar (4). Remove circuit 6 lead, circuit 49 lead, and two grommets (11 and 12) from distribution box (6). Discard grommets and lockwasher.

3. Remove screw (13), lockwasher (14), circuit 10, 14, 15, 27E lead (15), and circuit 450A lead (16) from bus bar (4). Remove circuit 10, 14, 15, 27E lead and grommet (17) from distribution box (6). Discard grommet and lockwasher.
4. Remove screw (18), lockwasher (19), and wiring harness (20) from bus bar (4). Discard lockwasher.

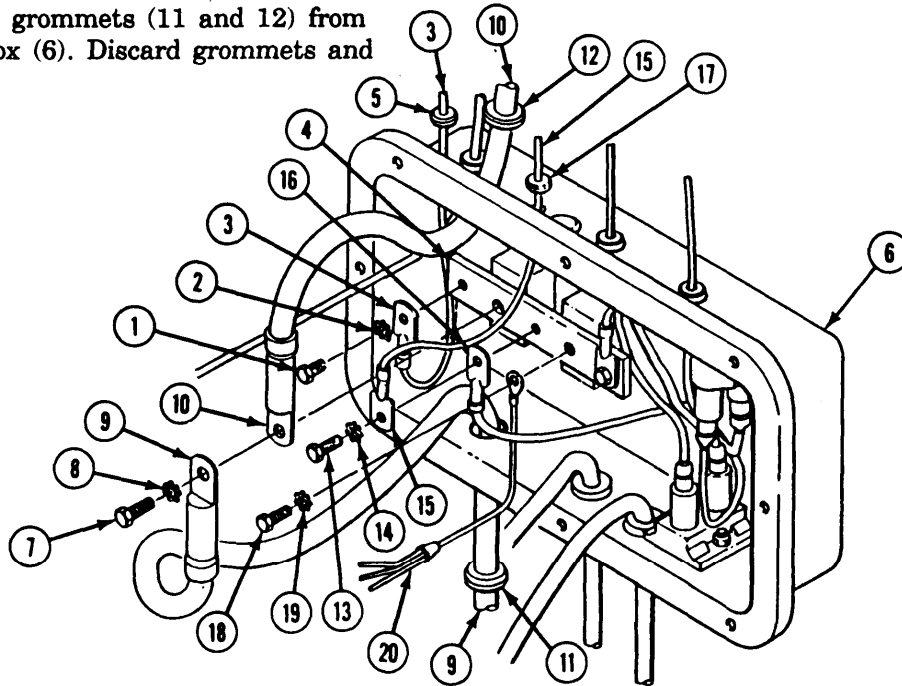

GO TO NEXT PAGE

5. Disconnect circuit 450 lead (1) from circuit breaker (2). Remove circuit 450 lead and grommet (3) from distribution box (4). Discard grommet.
6. Disconnect circuit 450B lead (5) from circuit breaker (6). Remove circuit 450B lead and grommet (7) from distribution box (4). Discard grommet.

NOTE

If bilge pump circuit breakers must be removed, refer to page 16-12 for removal. If bilge pump circuit breakers are not to be removed, go to step 10.

7. Remove screw (8), lockwasher (9), and circuit 450C lead (10) from bus bar (11). Discard lockwasher.

8. Disconnect circuit 450C lead (10) from circuit breaker (12). Remove circuit 450C lead from distribution box (4).
9. Disconnect circuit 450A lead (13) from circuit breaker (14). Remove circuit 450A lead from distribution box (4).
10. Remove circuit 400 lead (15) and grommet (16) from distribution box (4). Discard grommet.
11. Remove circuit 2 lead (17) and grommet (18) from distribution box (4). Discard grommet.
12. Remove circuit 2A lead (19) and grommet (20) from distribution box (4). Discard grommet.

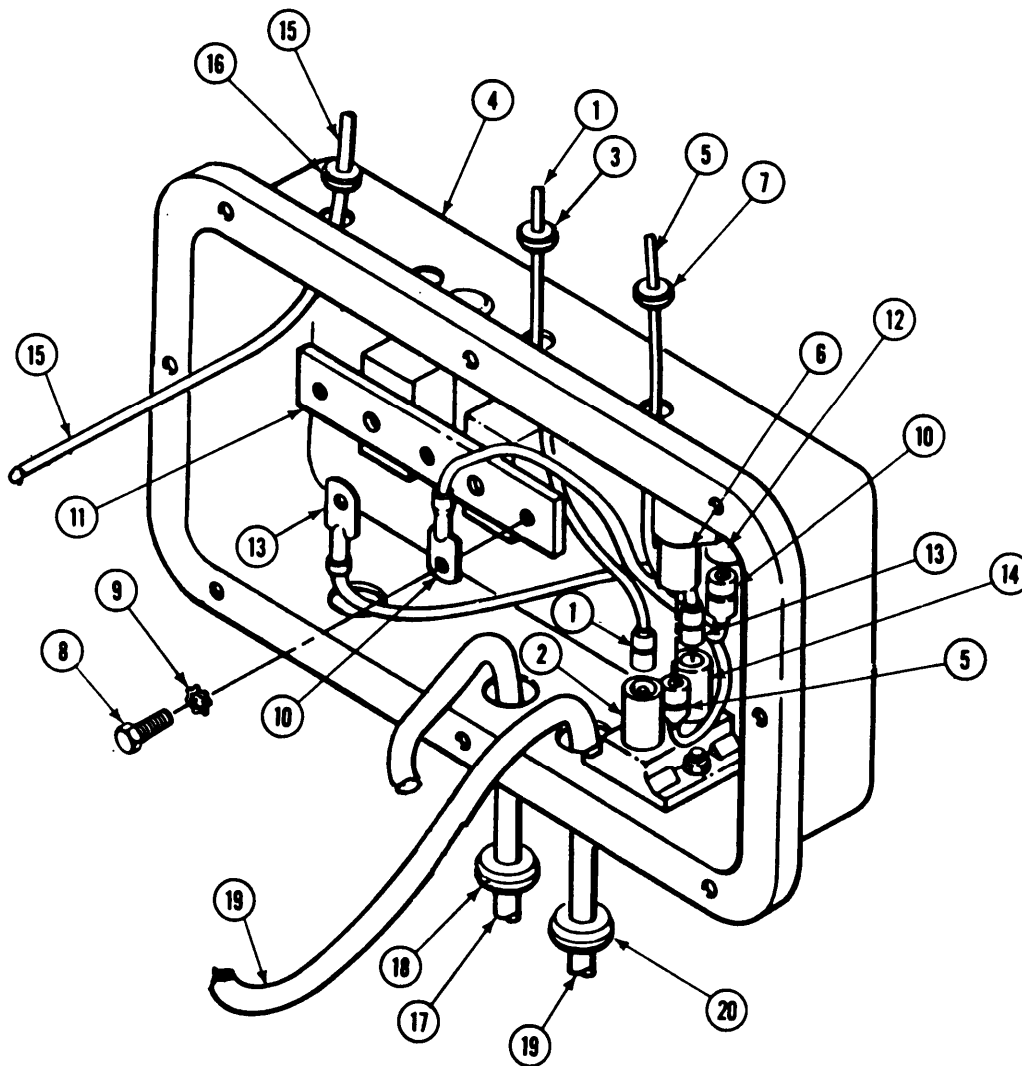

13. Remove five screws (1), lockwashers (2), and distribution box (3) from hull. Discard lockwashers.
14. Remove gasket (4) from distribution box (3). Discard gasket.

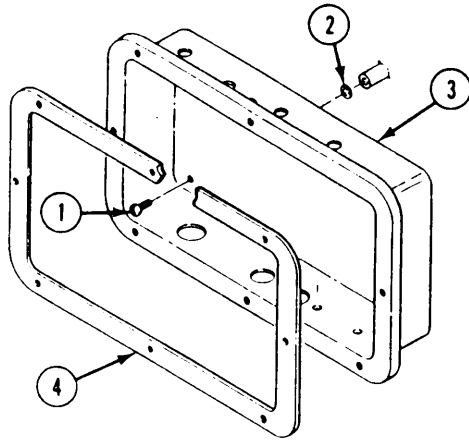

INSTALL

15. Install distribution box (3) on hull. Secure with five new lockwashers (2) and screws (1). Retain new gasket (4) for later installation.
16. Install new grommet (5) and circuit 2A lead (6) in distribution box (3).
17. Install new grommet (7) and circuit 2 lead (8) in distribution box (3).
18. Install new grommet (9) and circuit 400 lead (10) in distribution box (3).

NOTE

If bilge pump circuit breakers were removed, refer to page 16-12 for installation. If bilge pump circuit breakers were not removed, go to step 22.

19. Connect circuit 450A lead (11) to circuit breaker (12).
20. Connect circuit 450C lead (13) to circuit breaker (14).
21. Install circuit 450C lead (13) on bus bar (15). Secure with new lockwasher (16) and screw (17).
22. Install new grommet (18) and circuit 450B lead (19) in distribution box (3). Connect circuit 450B lead to circuit breaker (20).

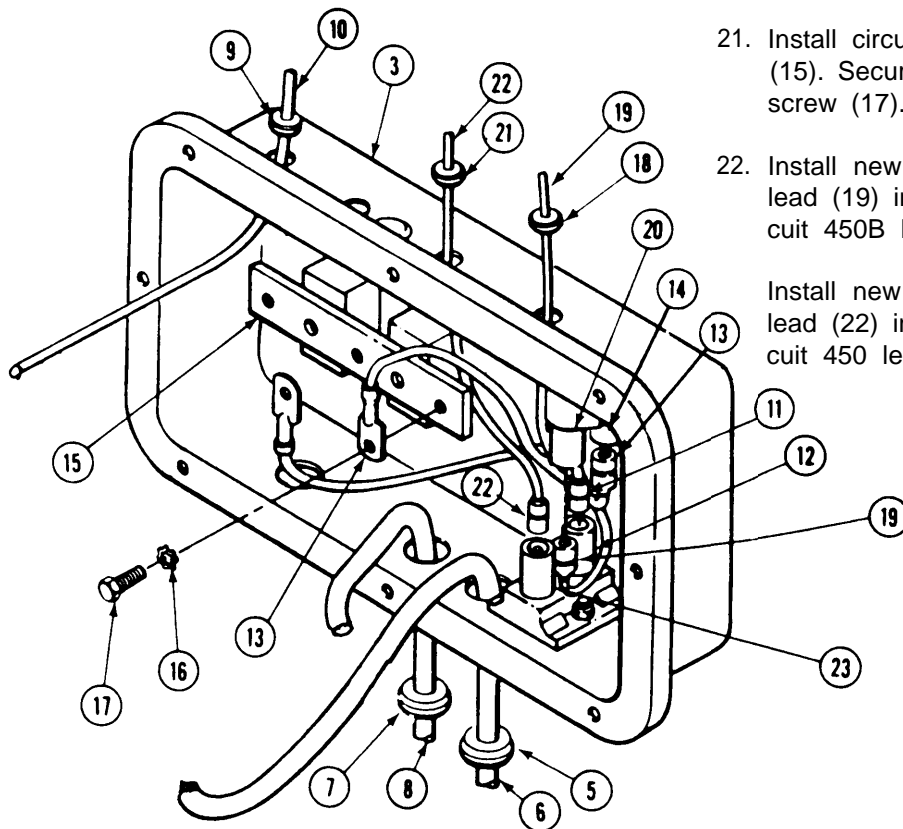

Install new grommet (21) and circuit 450 lead (22) in distribution box (3). Connect circuit 450 lead to circuit breaker (23).

GO TO NEXT PAGE

24. Install wiring harness (1) on bus bar (2). Secure with new lockwasher (3) and screw (4).
25. Install new grommet (5) and circuit 10, 14, 15, 27E lead (6) in distribution box (7). Install circuit 10, 14, 15, 27E lead (6) and circuit 450A lead (S) on bus bar (2). Secure with new lockwasher (9) and screw (10).
26. Install two new grommets (11 and 12), circuit 49 lead (13), and circuit 6 lead (14) in distribution box (7). Install circuit 49 lead (13) and circuit 6 lead (14) on bus bar (2). Secure with new lockwasher (15) and screw (16).
27. Install new grommet (17) and circuit 415 lead (18) in distribution box (7). Install circuit 415 lead (18) on bus bar (2). Secure with new lockwasher (19) and screw (20).

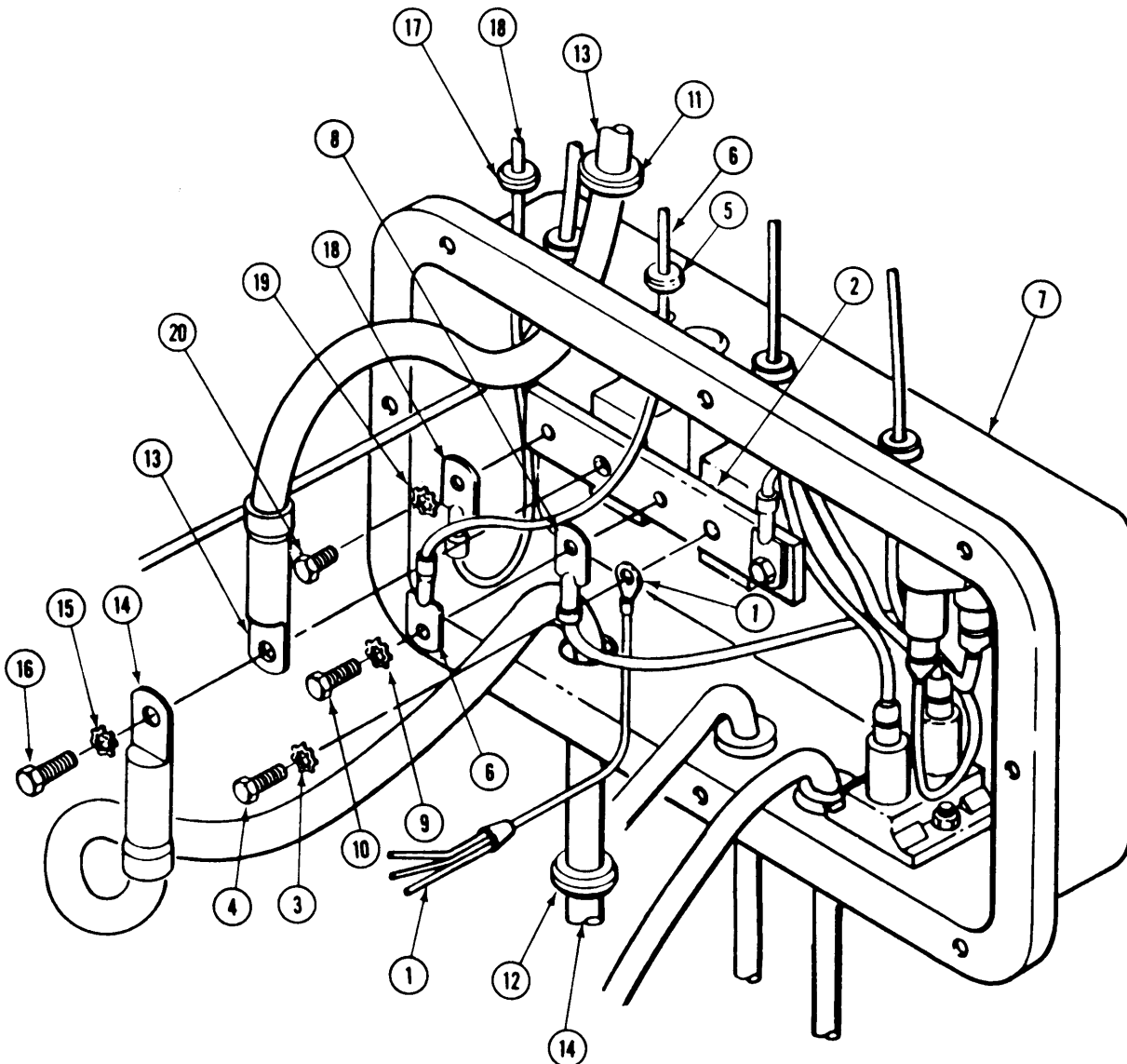

28. Apply one coat of adhesive to cleaned mounting surface of distribution box (1) and one side of new gasket (2).

29. Install new gasket (2) on coated mounting surface of distribution box (1).

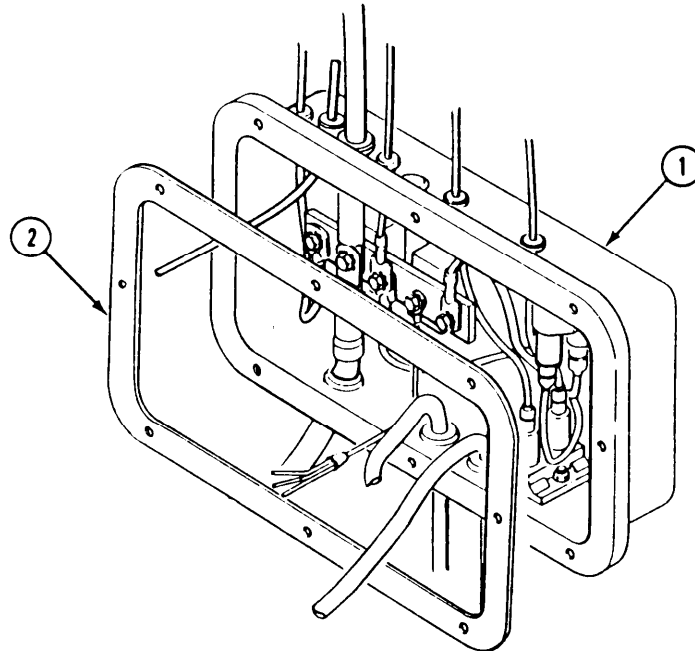

FOLLOW-THROUGH STEPS

1. Install master switch panel (page 9-22).
 2. Connect battery ground lead (page 13-2).

3. Start engine (see your -10). Check that distribution box is operable.

4. Stop engine (see your -10).

END OF TASK

REPLACE DISTRIBUTION BOX ASSEMBLY FOR 100 AMP GENERATOR SYSTEM (M577A2 ONLY)

DESCRIPTION

This task covers: Remove (page 12-28). Install (page 12-30),

INITIAL SETUP

Tools:

General Mechanics Tool Kit (Item 30, App D)

References:

See your -10

Materials/Parts:

Sealing compound (Item 52, App C)
 Gasket
 Grommet (9)
 Lockwasher (5)
 Lockwasher (5)

Equipment Conditions:

Engine stopped (see your -10)
 Carrier blocked (see your -10)
 Battery ground lead disconnected (page 13-2)
 Master switch panel assembly removed (page 9-22)

Personnel Required:

Unit Mechanic

REMOVE

1. Remove screw (1), lockwasher (2), and circuit 415 lead (3) from bus bar (4). Remove circuit 415 lead and grommet (5) from distribution box (6). Discard grommet and lockwasher.
2. Remove screw (7), lockwasher (8), circuit 6 lead (9), and circuit 49 lead (10) from bus bar (4). Remove circuit 6 lead, circuit 49 lead, and two grommets (11 and 12) from distribution box (6). Discard grommets and lockwasher.
3. Remove screw (13), lockwasher (14), circuit 10, 14, 15, 27E lead (15), and circuit 450A lead (16) from bus bar (4). Remove circuit 10, 14, 15, 27E lead and grommet (17) from distribution box (6). Discard grommet and lockwasher.
4. Remove screw (18), lockwasher (19), and wiring harness (20) from bus bar (4). Discard lockwasher.

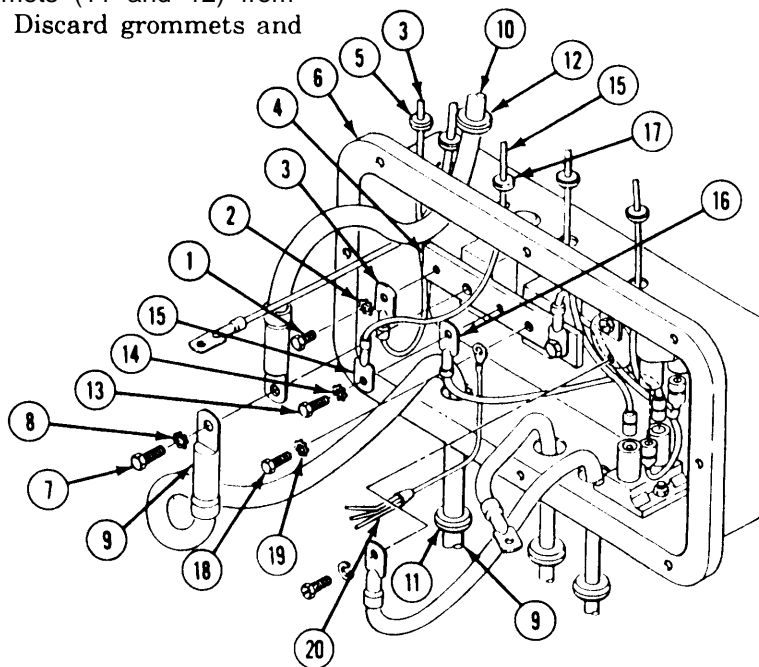

5. Remove screw (1), lockwasher (2), and circuit 3 lead (3) from circuit breaker (4). Remove circuit 3 lead and grommet (5) from distribution box (6), Discard grommet and lockwasher.
6. Disconnect circuit 450 lead (1) from circuit breaker (8). Remove circuit 450 lead and grommet (9) from distribution box (6), Discard grommet.
7. Disconnect circuit 450B lead (10) from circuit breaker (11). Remove circuit 450B lead and grommet (12) from distribution box (6). Discard grommet
9. Disconnect circuit 450C lead (15) from circuit breaker (17).
10. Disconnect circuit 450A lead (18) from circuit breaker (19).
11. Remove circuit 400 lead and grommet (20) from distribution box (21). Discard grommet.
12. Remove circuit 2 lead (22) and grommet (23) from distribution box (6). Discard grommet.

NOTE

If bilge pump circuit breakers must be removed, refer to page 16-12 for removal. If bilge pump circuit breakers are not to be removed, go to step 11.

8. Remove screw (13), lockwasher (14), and circuit 450C lead (15) from bus bar (16). Discard lockwasher.

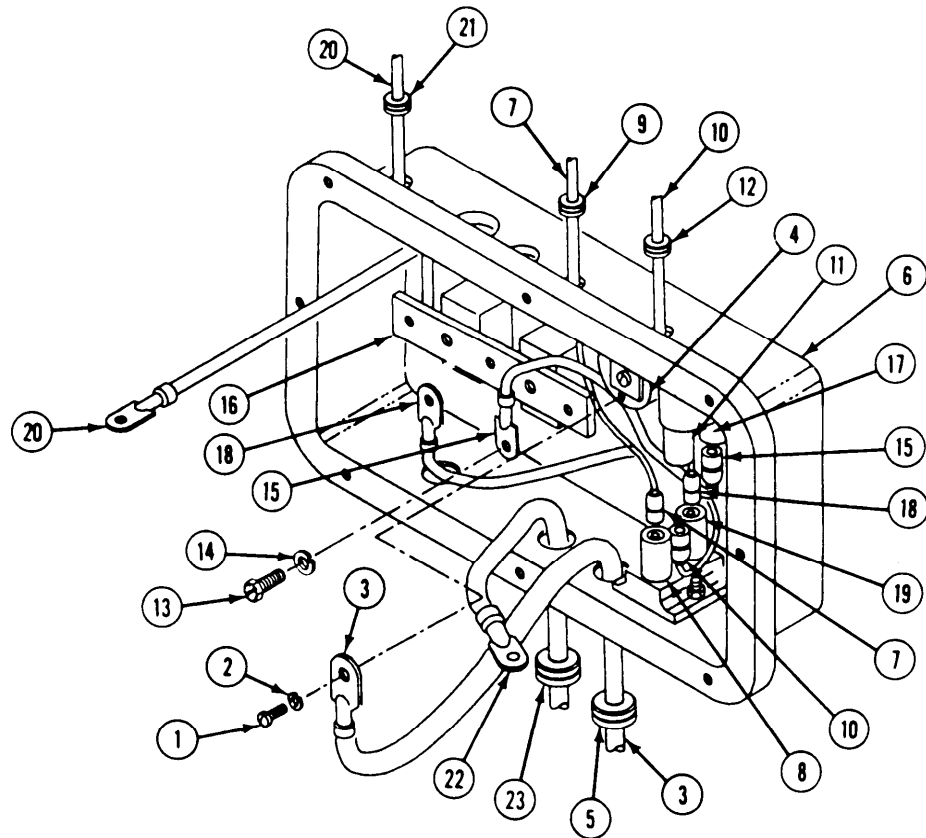

GO TO NEXT PAGE

13. Remove five screws (1), lockwashers (2), and distribution box (3) from hull. Discard lockwashers.
14. Remove gasket (4) from distribution box (3). Discard gasket.

INSTALL

15. Install distribution box assembly (3) on hull. Secure with five new lockwashers (2) and screws (1).

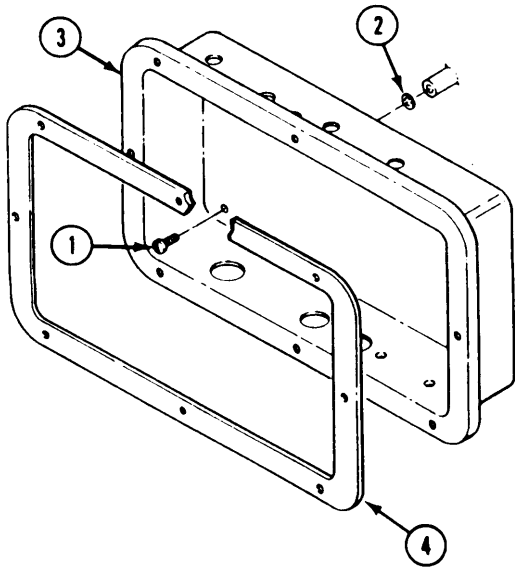

16. Install new grommet (5) and circuit 2 lead (6) in distribution box (3).
17. Install new grommet (7) and circuit 400 lead (8) in distribution box (3).

NOTE

If bilge pump circuit breakers were removed, refer to page 16-12 for installation. If bilge pump circuit breakers were not removed, go to step 21.

18. Connect circuit 450C lead (9) to circuit breaker (10).

19. Install circuit 450C lead (9) on bus bar (11). Secure with new lockwasher (12) and screw (13).

20. Connect circuit 450A lead (14) to circuit breaker (15).

21. Install new grommet (16) and circuit 450B lead (17) in distribution box (3). Connect circuit 450B lead to circuit breaker (18).

22. Install new grommet (19) and circuit 450 lead (20) in distribution box (3). Connect circuit 450 lead to circuit breaker (21).

23. Install new grommet (22) and circuit 3 lead (23) in distribution box (3). Install circuit 3 lead on circuit breaker (24). Secure with new lockwasher (25) and screw (26).

24. Install wiring harness (27) on bus bar (11). Secure with new lockwasher (28) and screw (29).

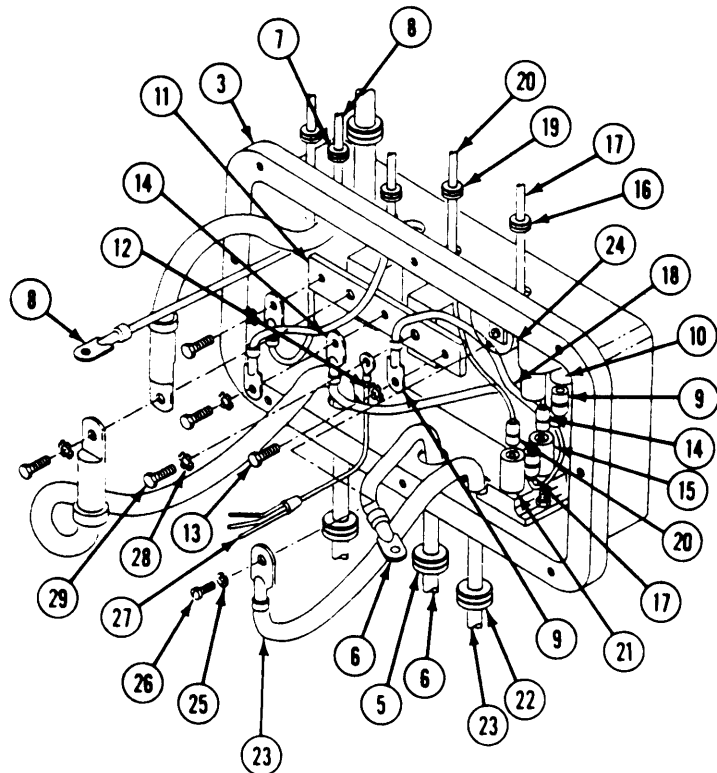

25. Install new grommet (1) and circuit 10, 14, 15, 27E lead (2) in distribution box (3). Install circuit 10, 14, 15, 27E lead (2) and circuit 450A lead (4) on bus bar (5). Secure with new lockwasher (6) and screw (7).
26. Install two new grommets (8 and 9), circuit 49 lead (10), and circuit 6 lead (11) in distribution box (3). Install circuit 49 lead (10) and circuit 6 lead (11) on bus bar (5). Secure with new lockwasher (12) and screw (13).
27. Install new grommet (14) and circuit 415 lead (15) in distribution box (3). Install circuit 415 lead (15) on bus bar (5). Secure with new lockwasher (16) and screw (17).
28. Apply one coat of adhesive to cleaned mounting surface of distribution box (18) and one side of new gasket (19).
29. Install new gasket (19) on coated mounting surface of distribution box (18).

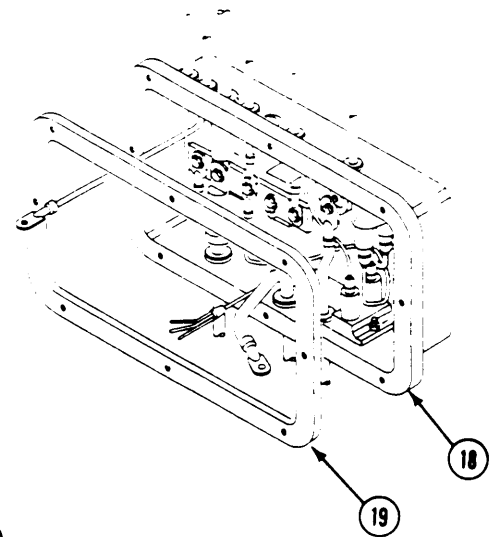
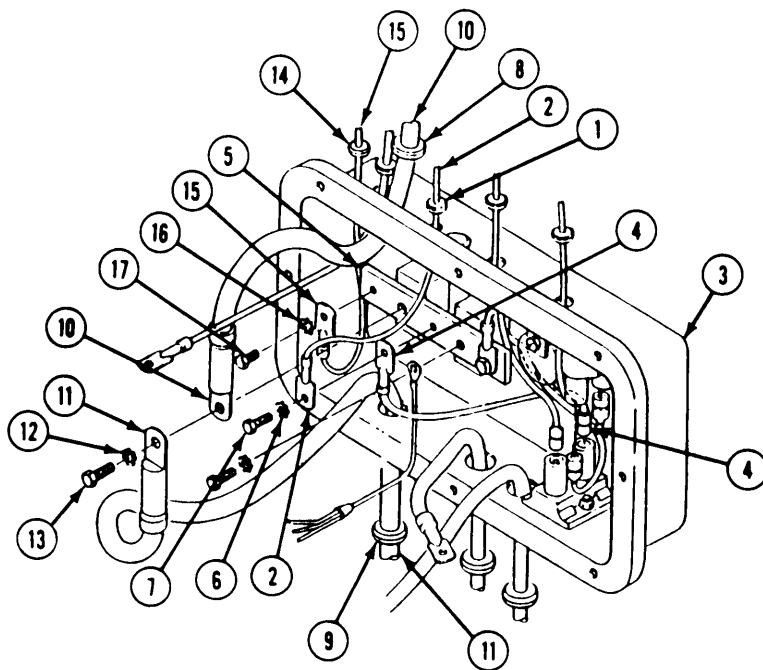

FOLLOW-THROUGH STEPS

1. Install master switch panel (page 9-22),
2. Connect battery ground lead (page 13-2).
3. Start engine (see your -10). Check that distribution box works properly.
4. Stop engine (see your -10).

END OF TASK

REPLACE DISTRIBUTION BOX ASSEMBLY FOR 100 AMP GENERATOR SYSTEM (M901A1 ONLY)

DESCRIPTION

This task covers: Remove (page 12-32). Install (page 12-34).

INITIAL SETUP

Tools:

General Mechanics Tool Kit (Item 30, App D)

References:

see your -lo

Materials/Parts:

Sealing compound Item 52, App C)
 Gasket
 Grommet (8)
 Lockwasher (5)
 Lockwasher (5)

Equipment Conditions:

Engine shutdown (see your -10)
 Carrier blocked (see your -10)
 Battery ground lead disconnected (page 13-2)
 Master switch panel assembly removed (page 9-16)

Personnel Require:

Unit Mechanic

REMOVE

1. Remove screw (1), lockwasher (2), circuit 6 lead (3), and cable assembly W8 leads (4 and 5) from bus bar (6). Remove circuit 6 lead (3) and grommet (7) from distribution box (8). Discard grommet and lockwasher.
2. Remove screw (9), lockwasher (10), circuit 10, 14, 15, 27E lead (11), and circuit 450A lead (12) from bus bar (6). Remove circuit 10, 14, 15, 27E lead (11) and grommet (13) from distribution box (8). Discard grommet and lockwasher.
3. Remove screw (14), lockwasher (15), circuit 49 lead (16), and cable assembly W8 leads (17 and 18) from bus bar (6). Remove circuit 49 lead (16), cable assembly W8 lead (19), and two grommets (20 and 21) from distribution box (8). Discard grommets and lockwasher.

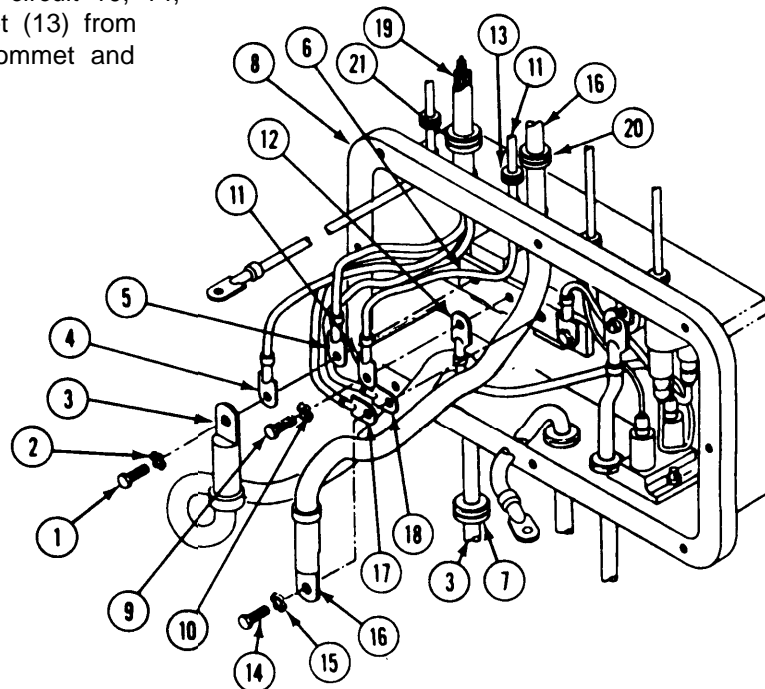

4. Remove screw (1), lockwasher (2), and circuit 3 lead (3) from circuit breaker (4), Remove circuit 3 lead (3) and grommet (5) from distribution box (6). Discard grommet and lockwasher.
5. Disconnect circuit 450 lead (7) from circuit breaker (8). Remove circuit 450 lead (7) and grommet (9) from distribution box (6). Discard grommet.
6. Disconnect circuit 450B lead (10) from circuit breaker (11). Remove circuit 450B lead (10) and grommet (12) from distribution box (6). Discard grommet.
7. Remove screw (13), lockwasher (14), and circuit 450C lead (15) from bus bar (16). Discard lockwasher.
8. Disconnect circuit 450C lead (15) from circuit breaker (17). Remove circuit 450C lead (15) from distribution box (6).
9. Disconnect circuit 450A lead (18) from circuit breaker (19). Remove circuit 450A lead (18) from distribution box (6).
10. Remove circuit 2 lead (20) and grommet (21) from distribution box (6). Discard grommet.
11. Remove circuit 400 lead (22) and grommet (23) from distribution box (6). Discard grommet.

NOTE

If bilge pump circuit breakers are to be removed, refer to page 16-12 for removal. If bilge pump circuit breakers are not to be removed, go to step 10.

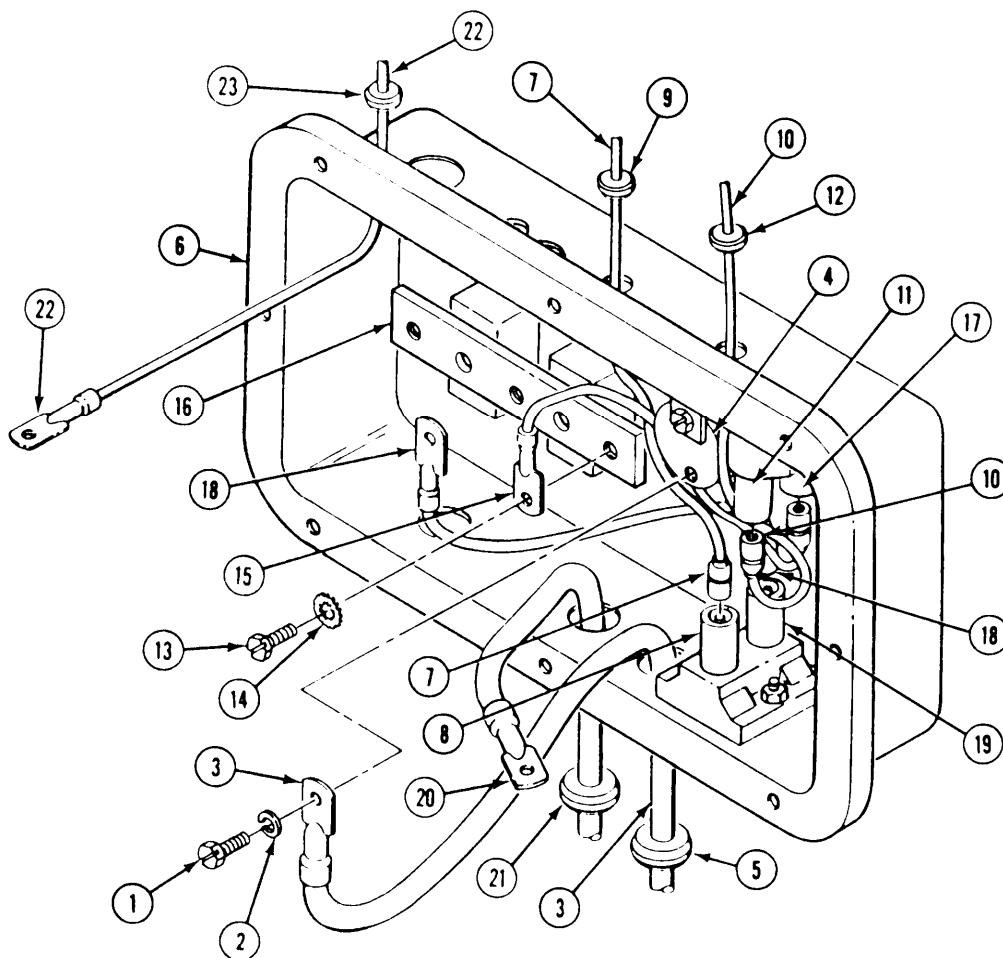

GO TO NEXT PAGE

12. Remove five screws (1), lockwashers (2), and distribution box (3) from hull. Discard lockwashers.
13. Remove gasket (4) from distribution box (3). Discard gasket.

INSTALL

14. Install distribution box assembly (3) on hull. Secure with five screws (1) and new lockwashers (2).

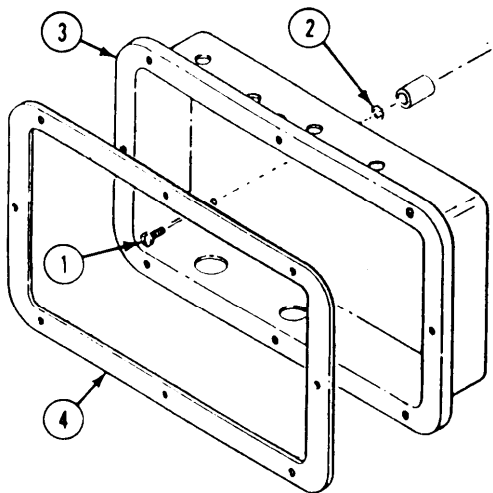

17. Connect circuit 450A lead (9) to circuit breaker (10).
18. Install 450C lead (7) on bus bar (11). Secure with new lockwasher (12) and screw (13).
19. Install new grommet (14) and circuit 450 lead (15) in distribution box (3). Connect circuit 450 lead (15) to circuit breaker (16).
20. Install new grommet (17) and circuit 450B lead (18) in distribution box (3). Connect circuit 450B lead (18) to circuit breaker (19).
21. Install new grommet (20) and circuit 2 lead (21) in distribution box (3).
22. Install new grommet (22) and circuit 3 lead (23) in distribution box (3). Install circuit 3 lead (23) on circuit breaker (24). Secure with new lockwasher (25) and screw (26).

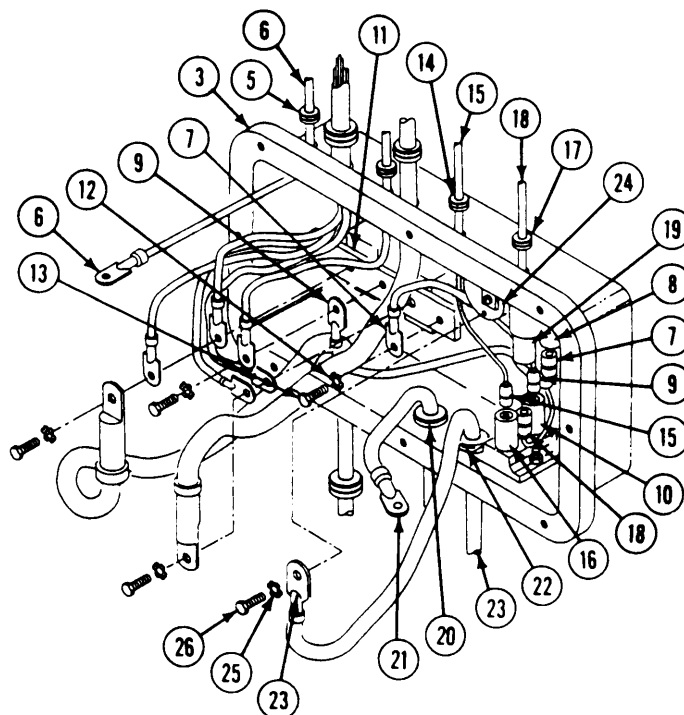

15. Install new grommet (5) and circuit 400 lead (6) in distribution box (3).

NOTE

If bilge pump circuit breakers were removed, refer to page 16-12 for installation. If bilge pump circuit breakers were not removed, go to step 19.

16. Connect circuit 450C lead (7) to circuit breaker (8).

23. Install two new grommets (1 and 2), cable assembly W8 lead (3), and circuit 49 lead (4) in distribution box (5). Install circuit 49 lead (4) and cable assembly W8 lead (3) on bus bar (6). Secure with new lockwasher (7) and screw (8).
24. Install new grommet (9) and circuit 10, 14, 15, 27E lead (10) in distribution box (5). Install circuit 10, 14, 15, 27E lead (10) and circuit 450A lead (11) on bus bar (6). Secure with new lockwasher (12) and screw (13).
25. Install new grommet (14) and circuit 6 lead (15) in distribution box (5). Install circuit 6 lead (15) and cable assembly W8 leads (3) on bus bar (6). Secure with new lockwasher (16) and screw (17).
26. Apply one coat of adhesive to cleaned mounting surface of distribution box (5) and one side of new gasket (18).
27. Install new gasket (18) on coated mounting surface of distribution box (5).

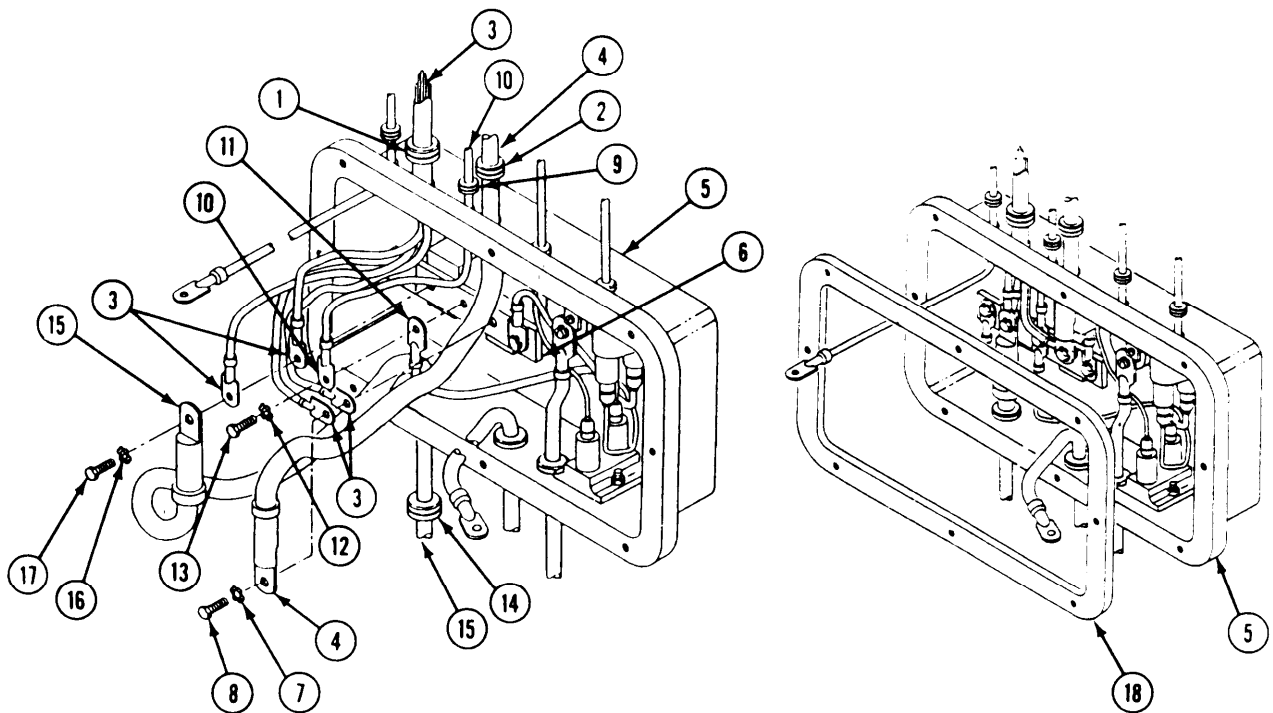

FOLLOW-THROUGH STEPS

1. Install master switch panel (page 9-16).
2. Connect battery ground lead (page 13-2).
3. Start engine (see your -10). Check that distribution box operates properly.
4. Shutdown engine (see your -10).

END OF TASK

REPLACE DISTRIBUTION BOX ASSEMBLY FOR 200 AMP GENERATOR SYSTEM (M741A1 ONLY)

DESCRIPTION

This task covers: Remove (page 12-36). Install (page 12-38).

INITIAL SETUP

Tools:

General Mechanics Tool Kit (Item 30, App D)

References:

See your -10

Materials/Parts:

Sealing compound (Item 52, App C)
 Gasket
 Grommet (8)
 lockwasher (5)
 Lockwasher (4)

Equipment Conditions:

Engine stopped/shutdown (see your -10)
 Carrier blocked (see your -10)
 Battery ground lead disconnected (page 13-2)
 Master switch panel assembly removed (page 9-16)

Personnel Required

Unit Mechanic

REMOVE

1. Remove screw (1), lockwasher (2), and circuit 6 lead (3) from bus bar (4). Remove circuit 6 lead and grommet (5) from distribution box (6). Discard grommet and lockwasher.
2. Remove screw (7), lockwasher (8), circuit 10, 14, 15, 27E lead (9), and circuit 450A lead (10) from bus bar (4). Remove circuit 10, 14, 15, 27E lead (9) and grommet (11) from distribution box (6). Discard grommet and lockwasher.
3. Remove screw (12), lockwasher (13), and circuit 49 lead (14) from bus bar (4). Remove circuit 49 lead (14) and grommet (15) from distribution box (6). Discard grommet and lockwasher.
4. Remove screw (16), lockwasher (17), circuit 2B lead (18), circuit 2 lead (19), and circuit 450C lead (20) from bus bar (4). Remove circuit 2 and 2B leads (18 and 19) with grommets (21 and 22) from distribution box (6). Discard grommets and lockwasher.

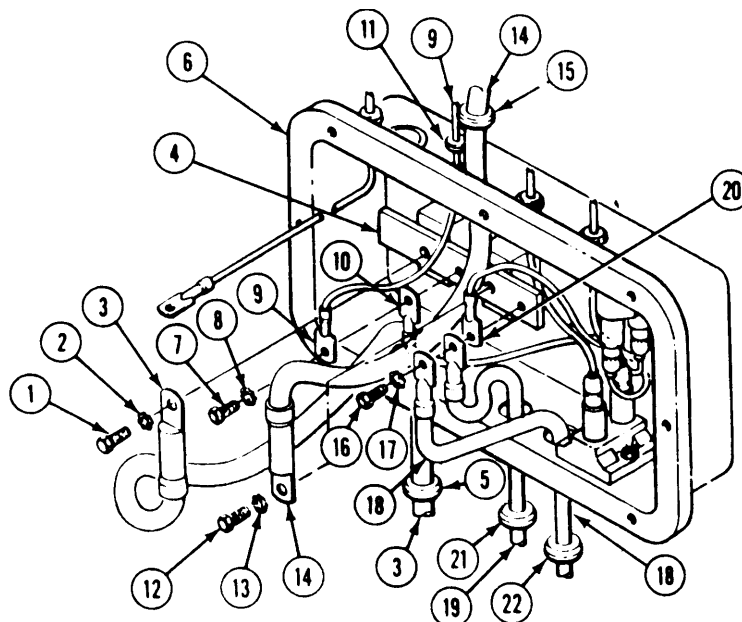

5. Disconnect circuit 450 lead (1) from circuit breaker (2). Remove circuit 450 lead (1) and grommet (3) from distribution box (4). Discard grommet.
6. Disconnect circuit 450B lead (5) from circuit breaker (6). Remove circuit 450B lead (5) and grommet (7) from distribution box (4). Discard grommet.

NOTE

If bilge pump circuit breakers must be removed, refer to page 16-12. If bilge pump circuit breakers are not to be removed, go to step 9.

7. Disconnect circuit 450C lead (8) from circuit breaker (9).
8. Disconnect circuit 450A lead (10) from circuit breaker (11).
9. Remove circuit 400 lead (12) and grommet (13) from distribution box (4). Discard grommet.

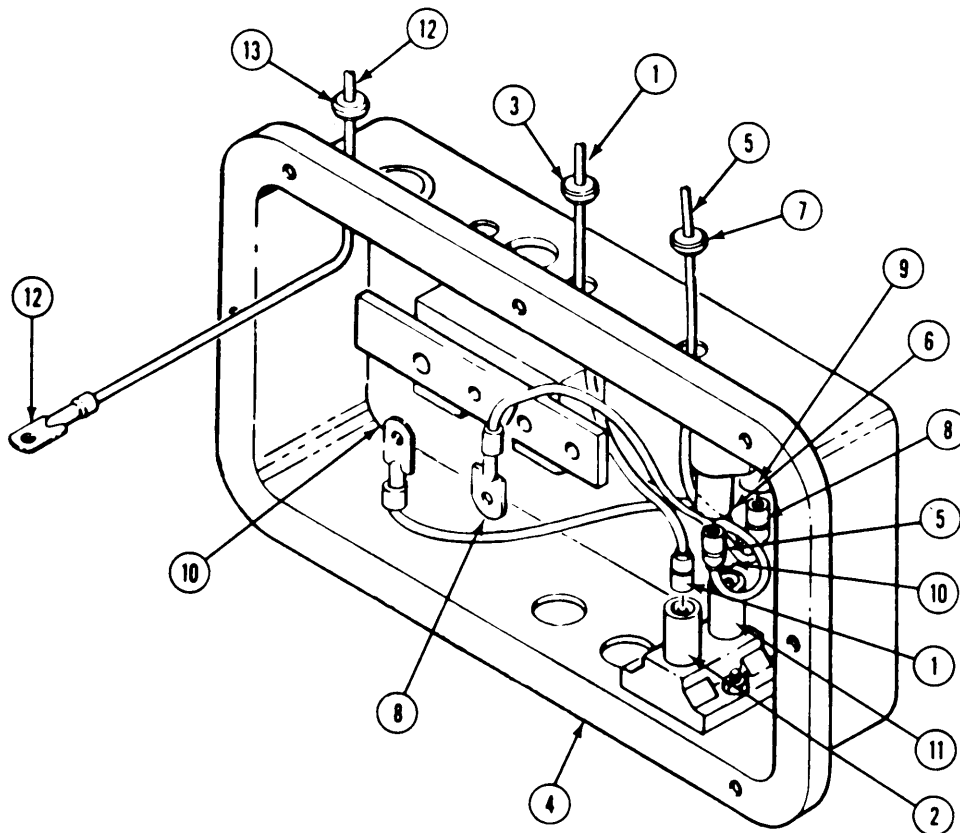

GO TO NEXT PAGE

10. Remove five screws (1), lockwashers (2), and distribution box (3) from hull. Discard lockwashers.
11. Remove gasket (4) from distribution box (3). Discard gasket.

INSTALL

12. Install distribution box assembly (3) on hull. Secure with five screws (1) and new lockwashers (2).

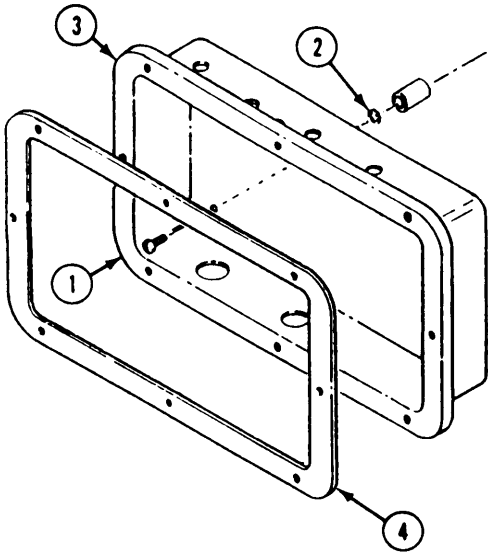

13. Install new grommet (5) and circuit 400 lead (6) in distribution box (3).

NOTE

If bilge pump circuit breakers were removed, refer to page 16-12 for installation. If bilge pump circuit breakers were not removed go to step 16.

14. Connect circuit 450C lead (7) to circuit breaker (8).

15. Connect circuit 450A lead (9) to circuit breaker (10).
16. Install new grommet (11) and circuit 450B lead (12) in distribution box (3). Connect circuit 450B lead (12) to circuit breaker (13).
17. Install new grommet (14) and circuit 450 lead (15) in distribution box (3). Connect circuit 450 lead (15) to circuit breaker (16).
18. Install new grommets (17 and 18), circuit 2B lead (19), and circuit 2 lead (20) in distribution box (3). Install circuit 450C lead (7), circuit 2B lead (19), and circuit 2 lead (20) on bus bar (21). Secure with new lockwasher (22) and screw (23).

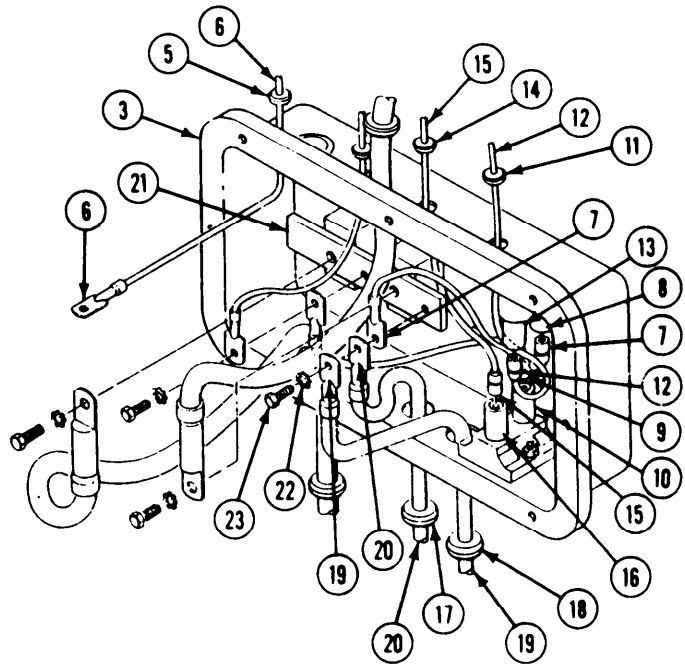

19. Install new grommet (1) and circuit 49 lead (2) in distribution box (3). Install circuit 49 lead (2) on bus bar (4). Secure with new lockwasher (5) and screw (6),
20. Install new grommet (7) and circuit 10, 14, 15, 27E lead (8) in distribution box (3). Install circuit 10, 14, 15, 27E lead (8) and circuit 450A lead (9) on bus bar (4). Secure with new lockwasher (10) and screw (11).

21. Install new grommet (12) and circuit 6 lead (13) in distribution box (3). Install circuit 6 lead (14) on bus bar (4). Secure with new lockwasher (15) and screw (16).
22. Apply one coat of adhesive to cleaned mounting surface of distribution box (17) and one side of new gasket (18).
23. Install new gasket (18) on coated mounting surface of distribution box (17).

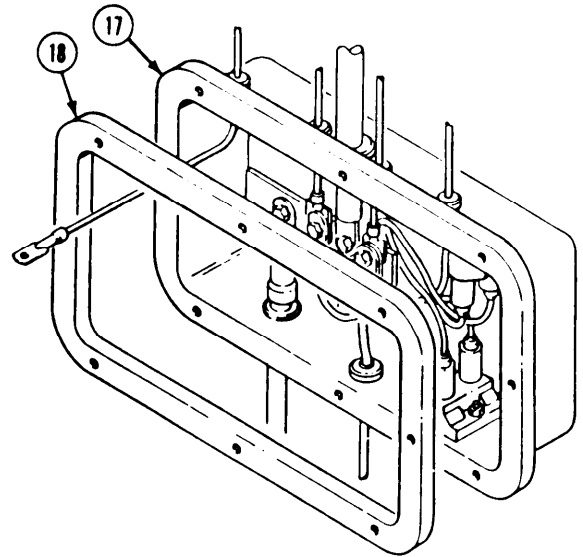
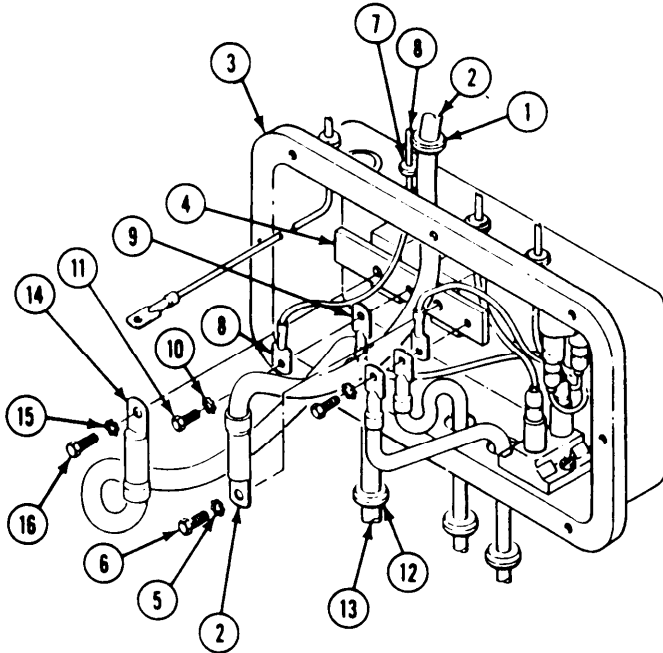

FOLLOW-THROUGH STEPS

1. Install master switch panel (page 9-16),
2. Connect battery ground lead (page 13-2).
3. start engine (see your -10). Check that distribution box works properly.
4. Stop engine. (see your -10).

END OF TASK

REPLACE DISTRIBUTION BOX ASSEMBLY FOR 100 AMP GENERATOR SYSTEM (M741A1 ONLY)

DESCRIPTION

This task covers: Remove (page 1240). Install (page 12-42).

INITIAL SETUP

Tools:

General Mechanics Tool Kit (Item 30, App D)

References:

See your -10

Materials/Parts:

Sealing compound (Item 52, App C)
 Gasket
 Grommet (8)
 Lockwasher (5)
 Lockwasher (5)

Equipment Conditions:

Engine stopped (see your -10)
 Carrier blocked (see your -10)
 Battery ground lead disconnected (page 13-2)
 Master switch panel assembly removed (page 9-16)

Personnel Required:

Unit Mechanic

REMOVE

1. Remove screw (1), lockwasher (2), and circuit 6 lead (3) from bus bar (4). Remove circuit 6 lead (3) and grommet (5) from distribution box (6). Discard grommet and lockwasher.
2. Remove screw (7), lockwasher (8), circuit 10, 14, 15, 27E lead (9), and circuit 450A lead (10) from bus bar (4). Remove circuit 10, 14, 15, 27E lead (9) and grommet (11) from distribution box (6). Discard grommet and lockwasher.
3. Remove screw (12), lockwasher (13), and circuit 49 lead (14) from bus bar (4). Remove circuit 49 lead (14) and grommet (15) from distribution box (6). Discard grommet and lockwasher.
4. Remove screw (16), lockwasher (17), circuit 450C lead (18), and circuit 2 lead (19) from bus bar (4). Remove circuit 2 lead (19) and grommet (20) from distribution box (6). Discard grommet and lockwasher.

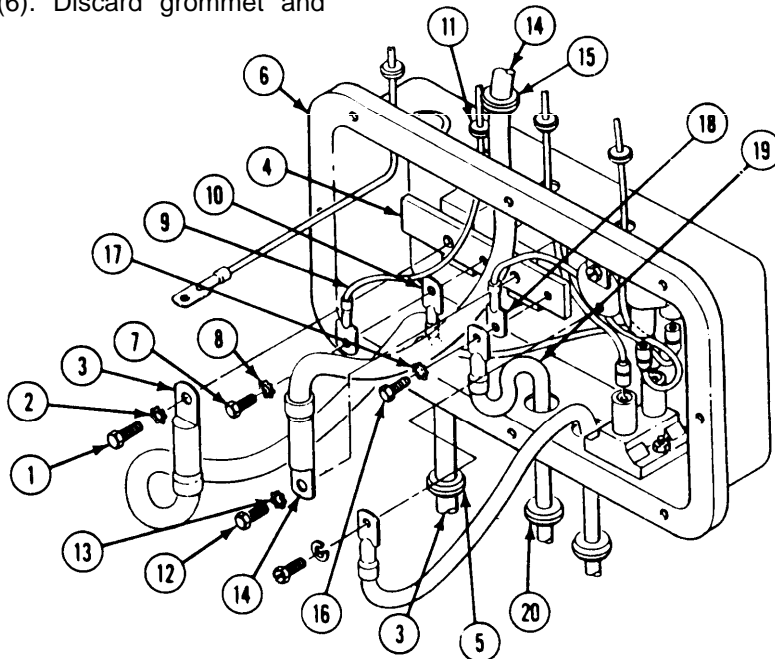

5. Remove screw (1), lockwasher (2) and circuit 3 lead (3) from circuit breaker (4). Remove circuit 3 lead (3) and grommet (5) from distribution box (6). Discard grommet and lockwasher.
6. Disconnect circuit 450 lead (7) from circuit breaker (8). Remove circuit 450 lead (7) and grommet (9) from distribution box (6). Discard grommet.
7. Disconnect circuit 450B lead (10) from circuit breaker (11). Remove circuit 450B lead (10) and grommet (12) from distribution box (6). Discard grommet.

NOTE

If bilge pump circuit breakers must be removed, refer to page 16-12 for removal. If bilge pump circuit breakers are not to be removed, go to step 10.

- s. Disconnect circuit 450C lead (13) from circuit breaker (14).
9. Disconnect circuit 450A lead (15) from circuit breaker (16).
10. Remove circuit 400 lead (17) and grommet (18) from distribution box (6). Discard grommet.

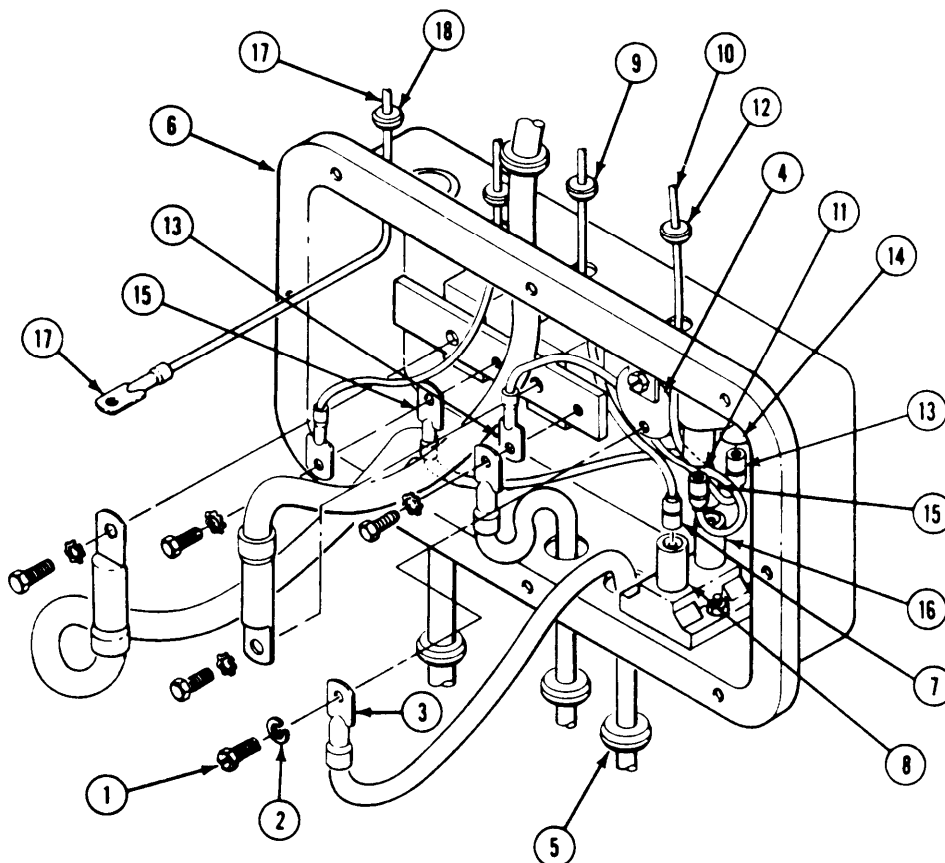

GO TO NEXT PAGE

11. Remove five screws (1), lockwashers (2), and distribution box (3) from hull. Discard lockwashers.
12. Remove gasket (4) from distribution box (3). Discard gasket.

INSTALL

13. Install distribution box assembly (3) on hull. Secure with five screws (1) and new lockwashers (2).

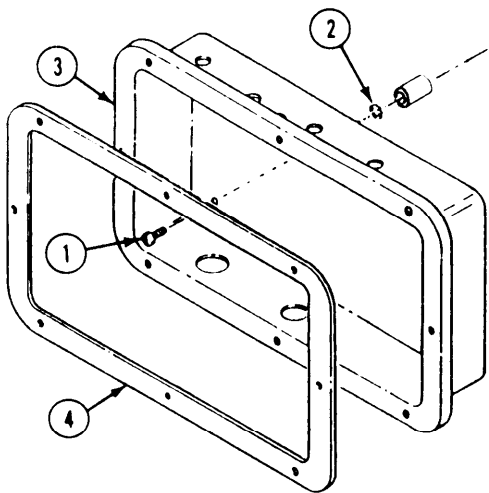

16. Connect circuit 450A lead (9) to circuit breaker (10).
17. Install new grommet (11) and circuit 450B lead (12) in distribution box (3). Connect circuit 450B lead (12) to circuit breaker (13).
18. Install new grommet (14) and circuit 450 lead (15) in distribution box (3). Connect circuit 450 lead (15) to circuit breaker (16).
19. Install new grommet (17) and circuit 3 lead (18) in distribution box (3). Install circuit 3 lead (18) on circuit breaker (19). Secure with new lockwasher (20) and screw (21).
20. Install new grommet (22) and circuit 2 lead (23) in distribution box (3). Install circuit 450C lead (7) and circuit 2 lead (23) on bus bar (24). Secure with new lockwasher (25) and screw (26).

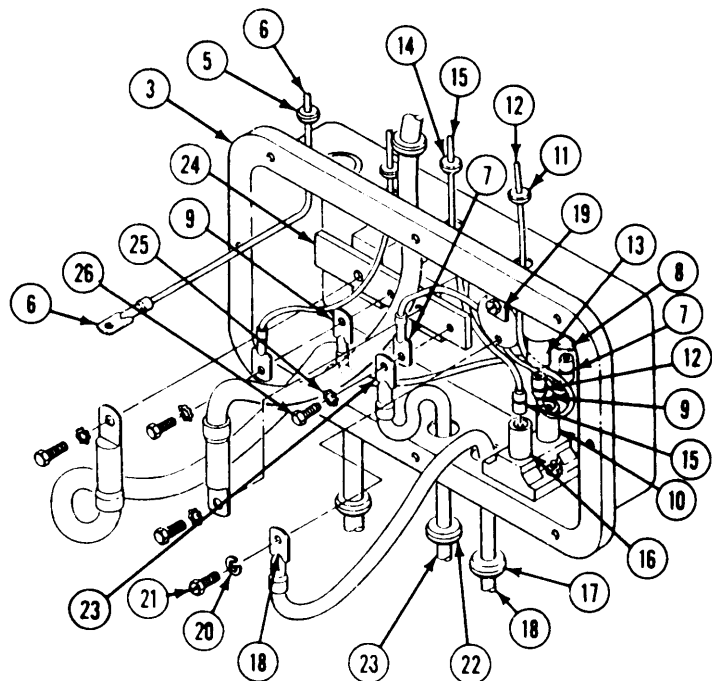

14. Install new grommet (5) and circuit 400 lead (6) in distribution box (3).

NOTE

If bilge pump circuit breakers must be removed, refer to page 16-12 for removal. If bilge pump circuit breakers are not to be removed, go to step 17.

15. Connect circuit 450C lead (7) to circuit breaker (8).

21. Install new grommet (1) and circuit 49 lead (2) in distribution box (3). Install circuit 49 lead (2) on bus bar (4). Secure with new lockwasher (5) and screw (6).
22. Install new grommet (7) and circuit 10, 14, 15, 27E lead (8) in distribution box (3). Install circuit 10, 14, 15, 27E lead (8) and circuit 450A lead (9) on bus bar (4). Secure with new lockwasher (10) and screw (11).

23. Install new grommet (12) and circuit 6 lead (13) in distribution box (3). Install circuit 6 lead (13) on bus bar (4). Secure with new lockwasher (14) and screw (15).
24. Apply one coat of adhesive to cleaned mounting surface of distribution box (16) and one side of new gasket (17).
25. Install new gasket (17) on coated mounting surface of distribution box (16).

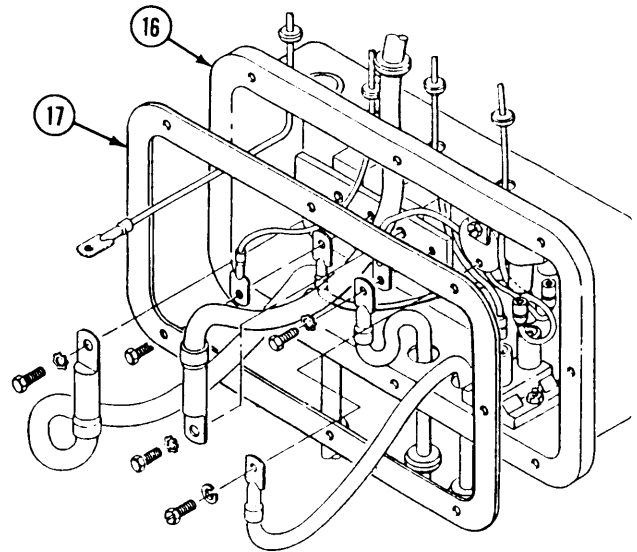
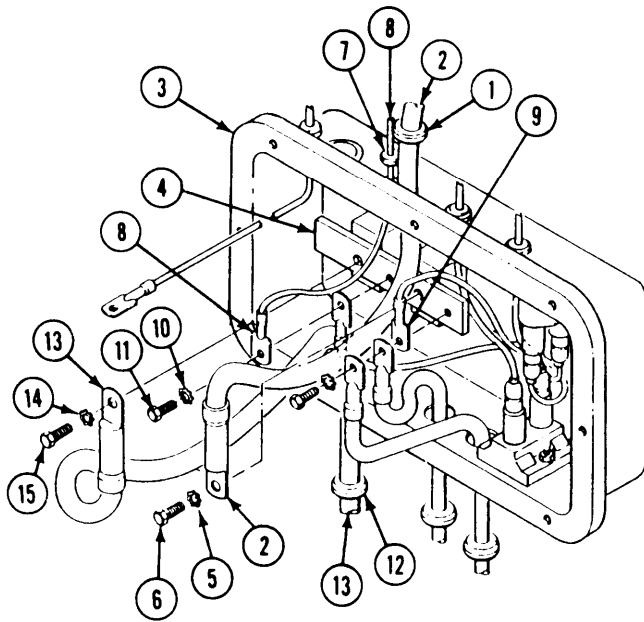

FOLLOW-THROUGH STEPS

1. Install master switch panel (page 9-16).
2. Connect battery ground lead (page 13-2).
3. Start engine (see your -10). Check that distribution box operates properly.
4. Stop engine (see your -10).

END OF TASK

REPLACE DISTRIBUTION BOX ASSEMBLY FOR 100 AMP GENERATOR SYSTEM (M113A2, M106A2, M125A2, M1064, AND M1059 ONLY)

DESCRIPTION

This task covers: Remove (page 12-44). Install (page 12-46).

INITIAL SETUP

Tools:

General Mechanics Tool Kit (Item 30, App D)

References:

See your -10

Materials/Parts:

Sealing compound (Item 52, App C)
 Gasket
 Grommet (8)
 Lockwasher (6)
 Lockwasher (5)

Equipment Conditions:

Engine stopped/shutdown (see your -10)
 Carrier blocked (see your -10)
 Battery ground lead disconnected (page 13-2)
 Master switch panel assembly removed (page 9-16)

Personnel Required:

Unit Mechanic

REMOVE

- For M113A2 and M1059 earners, remove screw (1), lockwasher (2), circuit 6 lead (3), and circuit 6L lead (5) from bus bar (4). Remove circuit 6 lead (3), circuit 6L lead (5), and two grommets (6 and 7) from distribution box (8). Discard grommets and lockwasher.
- For M106A2, M1064, and M125A2 carriers, remove screw (1), lockwasher (2), and circuit 6 lead (3) from bus bar (4). Remove circuit 6 lead (3) and grommet (6) from distribution box (8). Discard grommet and lockwasher.
- Remove screw (9), lockwasher (10), circuit 10, 14, 15, 27E lead (11), and circuit 450A lead (12) from bus bar (4). Remove circuit 10, 14, 15, 27E lead (11) and grommet (13) from distribution box (8). Discard grommet and lockwasher.
- Remove screw (14), lockwasher (15), and circuit 49 lead (16) from bus bar (4). Remove circuit 49 lead (16) and grommet (17) from distribution box (8). Discard grommet and lockwasher.

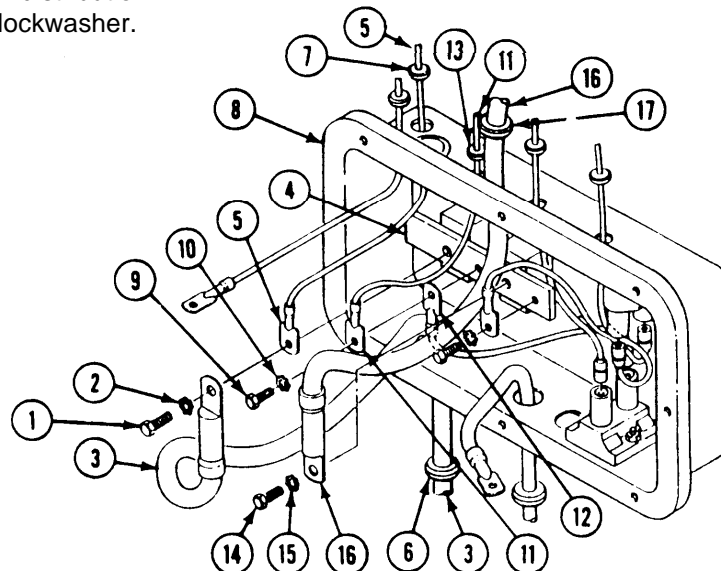

NOTE

If bilge pump circuit breakers must be removed, refer to page 16-12 for removal. If bilge pump circuit breakers are not to be removed, go to step 8.

5. Remove screw (1), lockwasher (2), and circuit 450C lead (3) from bus bar (4). Discard lockwasher.
6. Disconnect circuit 450C lead (3) from circuit breaker (5).
7. Remove circuit 450A lead (6) from circuit breaker (7).
8. Remove screw (8), lockwasher (9), and circuit 3 lead (10) from circuit breaker (11). Remove circuit 3 lead (10) and grommet (12) from distribution box (13). Discard grommet and lockwasher.
9. Remove circuit 2 lead (14) and grommet (15) from distribution box (13).
10. Remove circuit 450 lead (16) from circuit breaker (7). Remove circuit 450 lead (16) and grommet (17) from distribution box (13).
11. Disconnect circuit 450B lead (18) from circuit breaker (5). Remove circuit 450B lead (18) and grommet (19) from distribution box (13).
12. Remove circuit 400 lead (20) and grommet (21) from distribution box (13). Discard grommet.

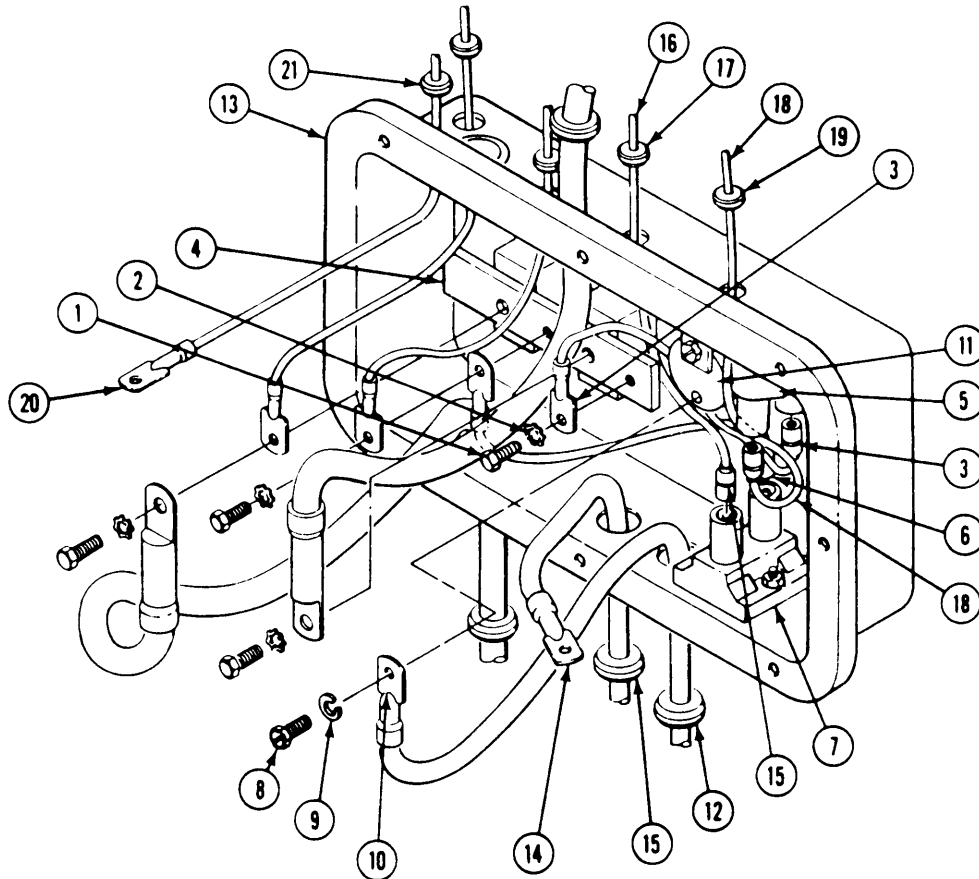

GO TO NEXT PAGE

13. Remove five screws (1), lockwashers (2), and distribution box (3) from hull. Discard lockwasher.
14. Remove gasket (4) from distribution box (3). Discard gasket,

INSTALL

15. Install distribution box assembly (3) on hull, Secure with five screws (1) and new lockwashers (2).

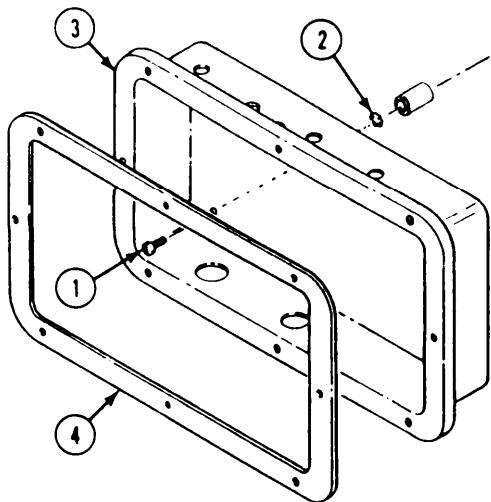

16. Install new grommet (5) and circuit 400 lead (6) in distribution box (3).
17. Install new grommet (7) and circuit 450B lead (8) in distribution box (3). Connect lead to circuit breaker (9).

NOTE

If bilge pump circuit breakers were removed, refer to page 16-12 for installation.

18. Install new grommet (10) and circuit 450 lead (11) in distribution box (3). Connect lead to circuit breaker (12).

NOTE

If bilge pump circuit breakers were not removed, go to step 21.

19. Connect circuit 450C lead (13) to circuit breaker (9).
20. Connect circuit 450A lead (14) to circuit breaker (12).
21. Install new grommet (15) and circuit 2 lead (16) in distribution box (3).
22. Install new grommet (17) and circuit 3 lead (18) in distribution box (3). Install circuit 3 lead on circuit breaker (19). Secure with new lockwasher (20) and screw (21).
23. Install circuit 450C lead (13) on bus bar (22). Secure with new lockwasher (23) and screw (24).
24. Install new grommet (25) and circuit 49 lead (26) in distribution box (3). Install circuit 49 lead on bus bar (22). Secure with new lockwasher (27) and screw (28).

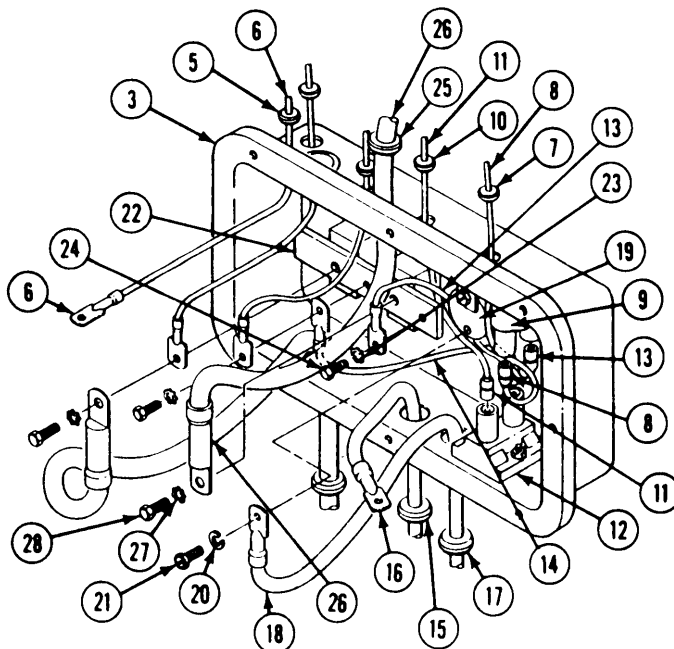

25. Install new grommet (1) and circuit 10, 14, 15, 27E lead (2) in distribution box (3). Install circuit 10, 14, 15, 27E lead (2) and circuit 450A lead (4) on bus bar (5). Secure with new lockwasher (6) and screw (7).
26. For M106A2, M1064, and M125A2, install new grommet (8) and circuit 6 lead (9) in distribution box (3). Install circuit 6 lead (9) on bus bar (5). Secure with new lockwasher (10) and screw (11).
27. For M113A2 and M1059, install two new grommets (8 and 12), circuit 6 lead (9), and circuit 6L lead (13) in distribution box (3). Install circuit 6 lead (9) and circuit 6L lead (13) on bus bar (5). Secure with new lockwasher (10) and screw (11).
28. Apply one coat of adhesive to cleaned mounting surface of distribution box (14) and one side of new gasket (15).
29. Install new gasket (15) on coated mounting surface of distribution box (14).

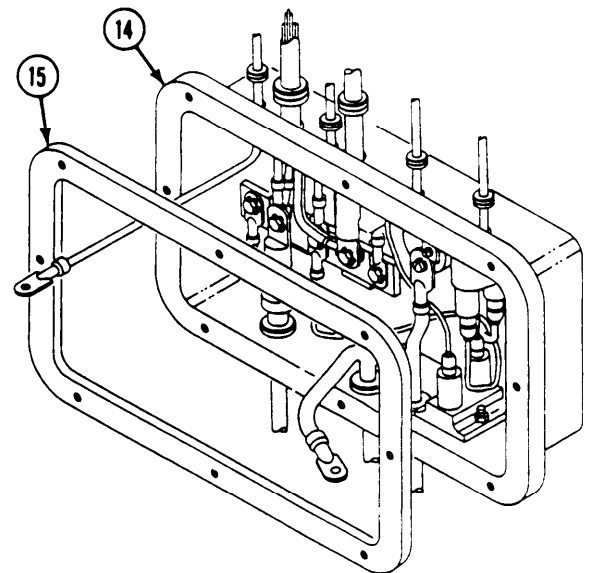
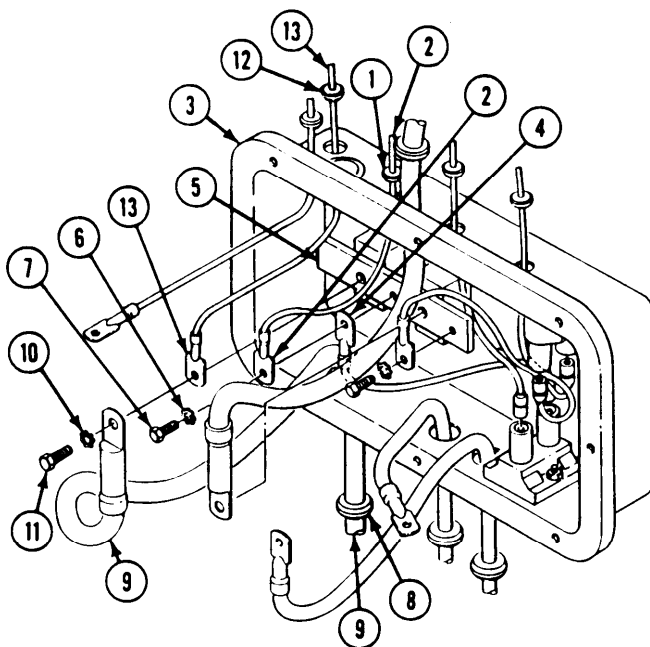

FOLLOW-THROUGH STEPS

1. Install master switch panel assembly (page 9-16).
2. Connect battery ground lead (page 13-2).
3. Start engine (see your -10). Check that distribution box operates properly.
4. Stop engine (see your -10).

END OF TASK

REPLACE DISTRIBUTION BOX ASSEMBLY FOR 200 AMP GENERATOR SYSTEM (M113A2, M106A2, M125A2, AND M1064 ONLY)

DESCRIPTION

This task covers: Remove (page 12-48). Install (page 12-50).

INITIAL SETUP

Tools:

General Mechanics Tool Kit (Item 30, App D)

References:

See your -10

Materials/Parts:

Sealing compound (Item 52, App C)
 Gasket
 Grommet (8)
 Lockwasher (5)
 Lockwasher (5)

Equipment Conditions:

Engine stopped/shutdown (see your -10)
 Carrier blocked (see your -10)
 Battery ground lead disconnected (page 13-2)
 Master switch panel assembly removed (page 9-16)

Personnel Required:

Unit Mechanic

REMOVE

1. For M113A2 carrier, remove screw (1), lockwasher (2), circuit 6 lead (3), and circuit 6L lead (4) from bus bar (5). Remove circuit 6 lead (3), circuit 6L lead (4), and two grommets (7 and 8) from distribution box (6). Discard grommets and lockwasher.
2. For M106A2, M125A2, and M1064 carriers, remove screw (1), lockwasher (2), and circuit 6 lead (3) from bus bar (5). Remove circuit 6 lead (3) and grommet (7) from distribution box (6). Discard grommet and lockwasher.

3. Remove screw (9), lockwasher (10), circuit 10, 14, 15, 27E lead (11), and circuit 450A lead (12) from bus bar (5). Remove circuit 10, 14, 15, 27E lead (11) and grommet (13) from distribution box (6). Discard grommet and lockwasher.
4. Remove screw (14), lockwasher (15), and circuit 49 lead (16) from bus bar (5). Remove circuit 49 lead (16) and grommet (17) from distribution box (6). Discard grommet and lockwasher.

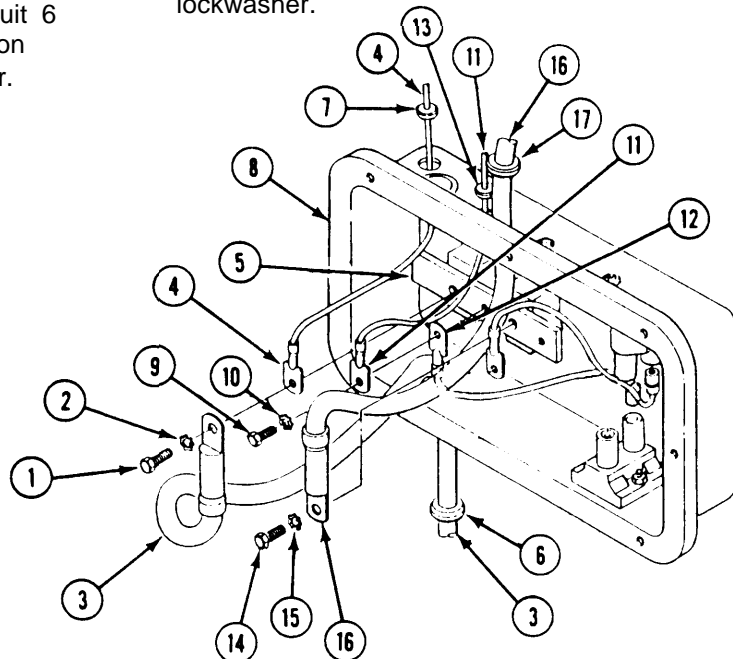

NOTE

If bilge pump circuit breakers must be removed, refer to page 16-12 for removal. If bilge pump circuit breakers are not to be removed, go to step 8.

5. Remove screw (1), lockwasher (2), and circuit 450C lead (3) from bus bar (4). Discard lockwasher.
6. Disconnect circuit 450C lead (3) from circuit breaker (5).
7. Remove circuit 450A lead (6) from circuit breaker (7).
8. Remove circuit 450 lead (8) from circuit breaker (7). Remove circuit 45C lead (8) and grommet (9) from distribution box (10). Discard grommet.
9. Disconnect circuit 450B lead (11) from circuit breaker (5). Remove circuit 450B lead (11) and grommet (12) from distribution box (10). Discard grommet.
10. Remove circuit 400 lead (13) and grommet (14) from distribution box (10). Discard grommet.
11. Remove grommet (15) and circuit 2 lead (16) from distribution box (10). Discard grommet.
12. Remove grommet (17) and circuit 2A lead (18) from distribution box (10). Discard grommet.

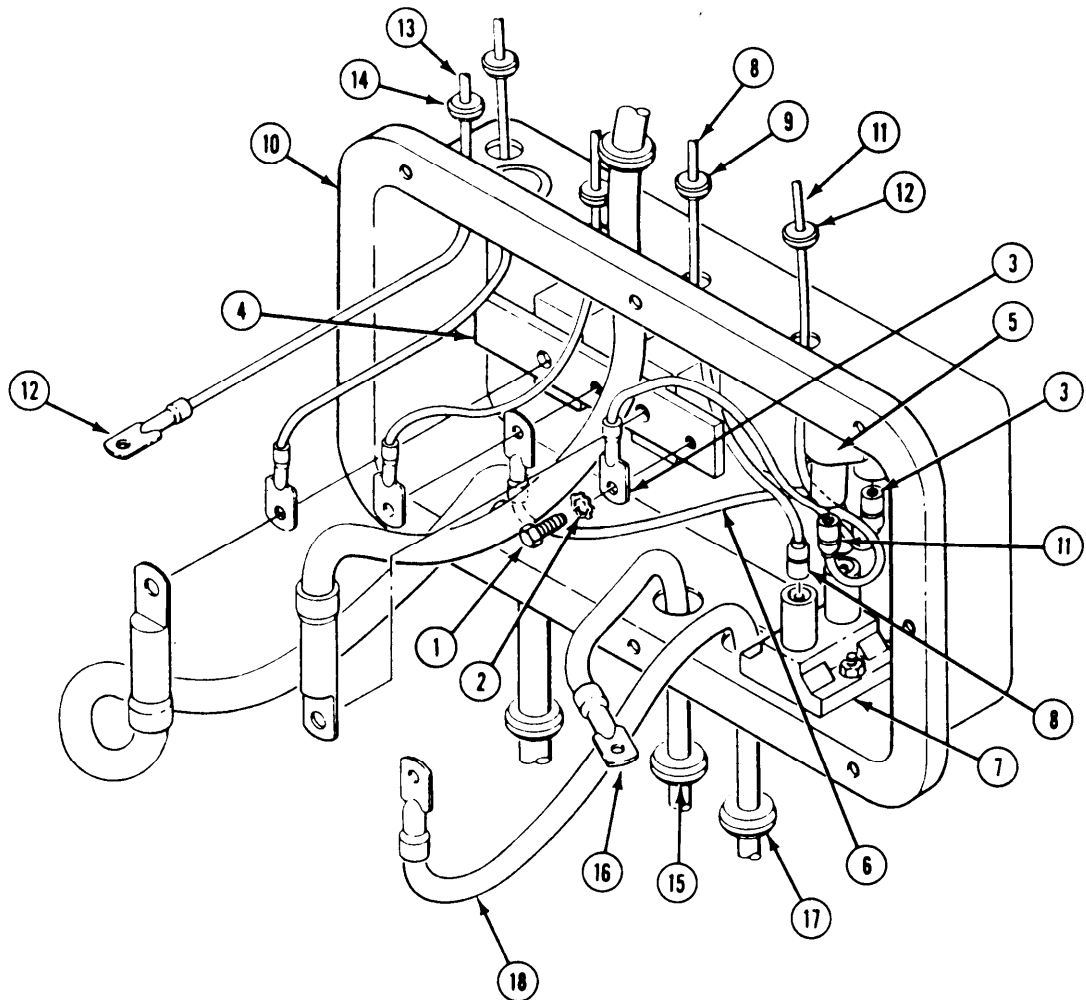

GO TO NEXT PAGE

11. Remove five screws (1), lockwashers (2), and distribution box (3) from hull. Discard lockwashers.
12. Remove gasket (4) from distribution box (3). Discard gasket.
17. Install new grommet (11) and circuit 450B lead (12) in distribution box (3). Connect lead to circuit breaker (8),
18. Install new grommet (13) and circuit 450 lead (14) in distribution box (3). Connect lead to circuit breaker (10).
19. Install new grommet (15) and circuit 2 lead (16) in distribution box (3).
20. Install new grommet (17) and circuit 2A lead (18) in distribution box (3).

INSTALL

13. Install distribution box assembly (3) on hull. Secure with five screws (1) and new lockwashers (2).

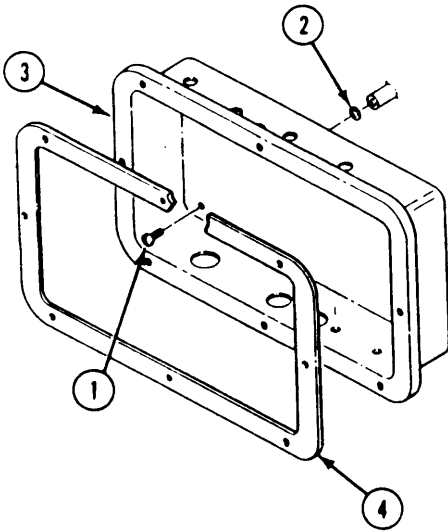

14. Install new grommet (5) and circuit 400 lead (6) in distribution box (3).

NOTE

If bilge pump circuit breakers were removed, refer to page 16-12 for installation. If bilge pump circuit breakers were not removed, go to step 17.

15. Connect circuit 450C lead (7) to circuit breaker (8).
16. Connect circuit 450A lead (9) to circuit breaker (10).

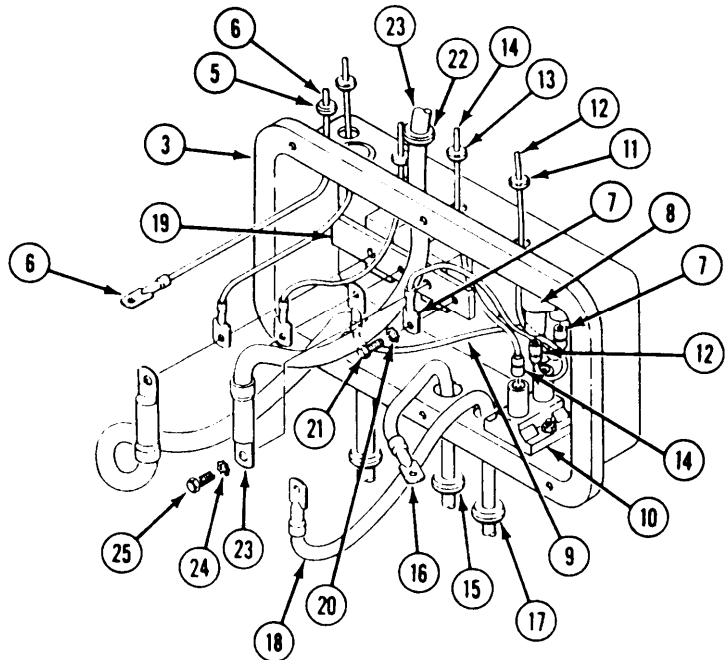

23. Install new grommet (1) and circuit 10, 14, 15, 27E lead (2) in distribution box (3). Install circuit 10, 14, 15, 27E lead (2) and circuit 450A lead (4) on bus bar (5). Secure with new lockwasher (6) and screw (7).
24. For M106A2, M125A2, and M1064, install new grommet (8) and circuit 6 lead (9) in distribution box (3). Install circuit 6 lead (9) on bus bar (5). Secure with new lockwasher (10) and screw (11).
25. For M1 13A2, install two new grommets (8 and 12), circuit 6 lead (9), and circuit 6L lead (13) in distribution box (3). Install circuit 6 lead (9) and circuit 6L lead (13) on bus bar (5). Secure with new lockwasher (10) and screw (11).
26. Apply one coat of adhesive to cleaned mounting surface of distribution box (3) and one side of new gasket (14).
27. Install new gasket (14) on coated mounting surface of distribution box (3).

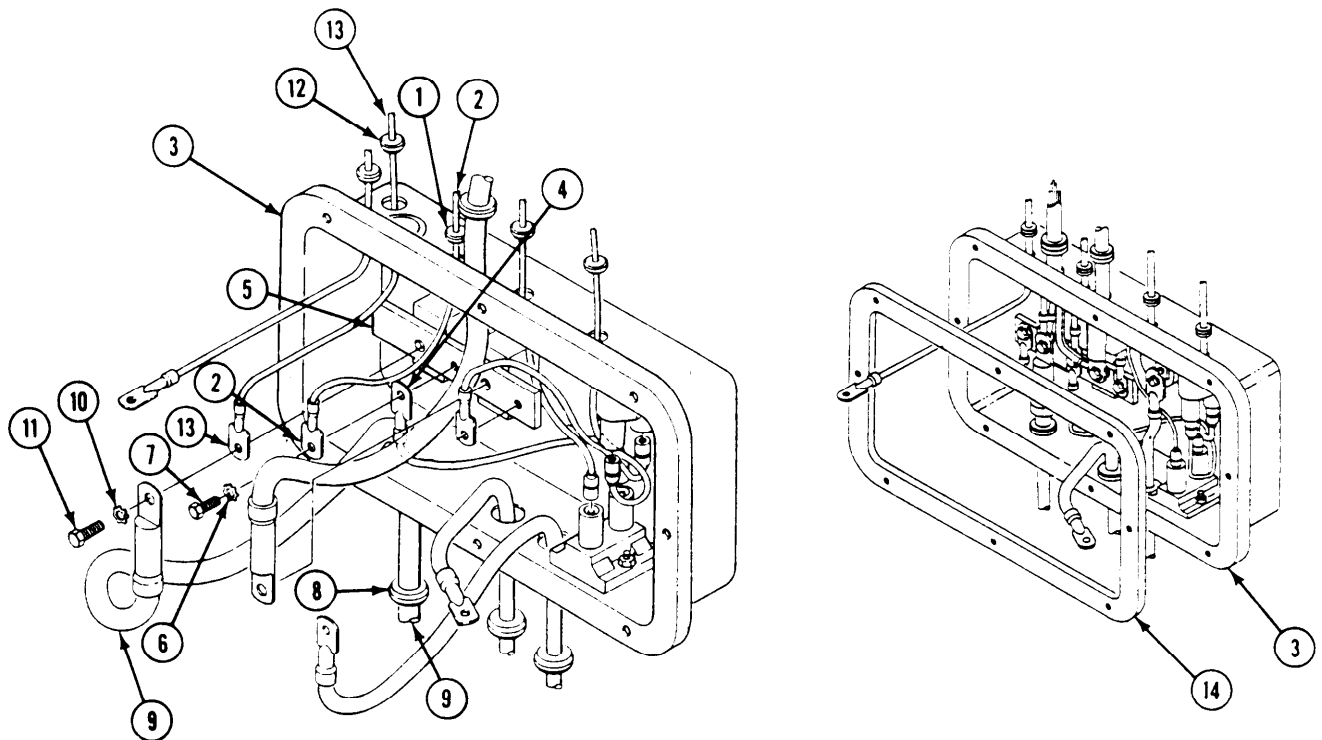

FOLLOW-THROUGH STEPS

1. Install master switch panel assembly (page 9-16).
2. Connect battery ground lead (page 13-2).
3. Start engine (see your -10). Check that distribution box operates properly.
4. Stop engine (see your -10).

END OF TASK

REPLACE DISTRIBUTION BOX ASSEMBLY FOR 200 AMP GENERATOR SYSTEM (M901A1 ONLY)

DESCRIPTION

This task covers: Remove (page 12-52). Install (page 12-54).

INITIAL SETUP

Tools:

General Mechanics Tool Kit (Item 30, App D)

References:

See your -10

Materials/Parts:

Sealing compound (Item 52, App C)
Gasket
Grommet (8)
Lockwasher (4)
Lockwasher (5)

Equipment Conditions:

Engine stopped/shutdown (see your -10)
Carrier blocked (see your -10)
Battery ground lead disconnected (page 13-2)
Master switch panel assembly removed (page 9-16)

Personnel Required:

Unit Mechanic

REMOVE

1. Remove screw (1), lockwasher (2), circuit 6 lead (3), and cable assembly W8 leads (4 and 5) from bus bar (6). Remove circuit 6 lead and grommet (7) from distribution box (8). Discard grommet and lockwasher.
2. Remove screw (9), lockwasher (10), circuit 10, 14, 15, 27E lead (11), and circuit 450A lead (12) from bus bar (6). Remove circuit 10, 14, 15, 27E lead and grommet (13) from distribution box (8). Discard grommet and lockwasher.
3. Remove screw (14), lockwasher (15), circuit 49 lead (16), and cable assembly W8 leads (17 and 18) from bus bar (6). Remove circuit 49 lead, cable assembly W8 lead (19), and two grommets (20 and 21) from distribution box (8). Discard grommets and lockwasher.

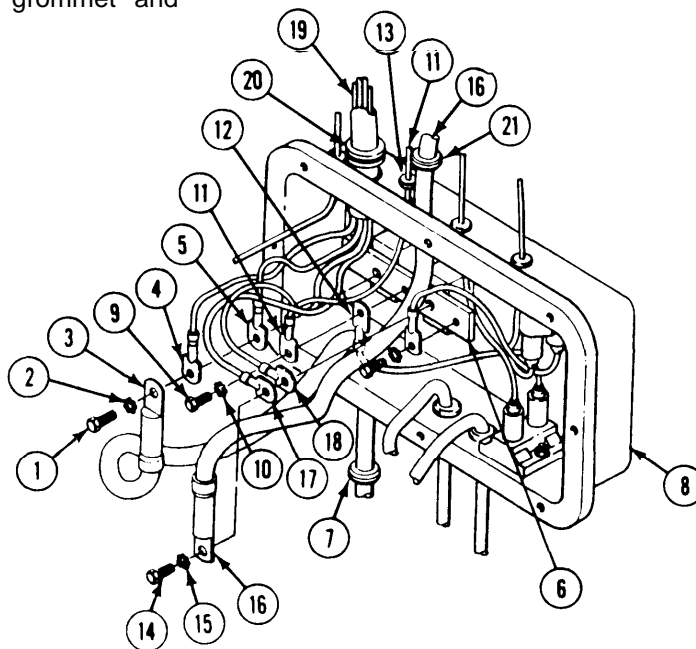

4. Remove circuit 2A. lead (1) and grommet (2) from distribution box (3). Discard grommet.
5. Remove circuit 2 lead (4) and grommet (5) from distribution box (3). Discard grommet.
6. Disconnect circuit 450 lead (6) from circuit breaker (7). Remove circuit 450 lead and grommet (S) from distribution box (3). Discard grommet.
7. Disconnect circuit 450B lead (9) from circuit breaker (10). Remove circuit 450B lead and grommet (11) from distribution box (3). Discard grommet.

NOTE

If bilge pump circuit breakers are to be removed, refer to page 16–12 for removal. If the bilge pump circuit breakers are not to be removed, go to step 11.

8. Remove screw (12), lockwasher (13), and circuit 450C lead (14) from bus bar (15). Discard lockwasher.
9. Disconnect circuit 450C lead (14) from circuit breaker (16). Remove circuit 450C lead from distribution box (3).
10. Disconnect circuit 450A lead (17) from circuit breaker (1S). Remove circuit 450A lead from distribution box (3).
11. Remove circuit 400 lead (19) and grommet (20) from distribution box (3). Discard grommet.

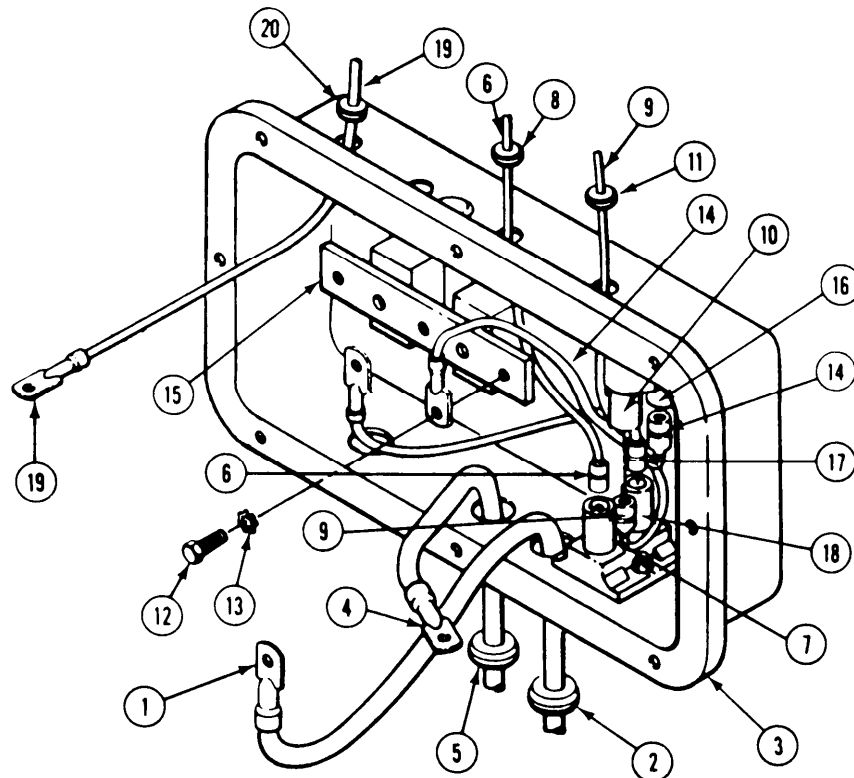

GO TO NEXT PAGE

12. Remove five screws (1), lockwashers (2), and distribution box (3) from hull. Discard lockwashers,
13. Remove gasket (4) from distribution box (3). Discard gasket.

INSTALL

14. Install distribution box assembly (3) on hull. Secure with five screws (1) and new lockwashers (2).

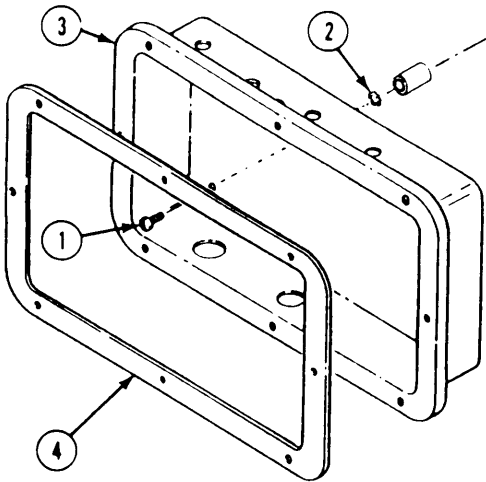

15. Install new grommet (5) and circuit 400 lead (6) in distribution box (3).
16. Install new grommet (7) and circuit 450B lead (8) in distribution box (3). Connect circuit 450B lead to circuit breaker (9).

NOTE

If bilge pump circuit breakers were removed, refer to page 16-12 for installation. If the bilge pump circuit breakers were not removed, go to step 20.

17. Connect circuit 450C lead (10) to circuit breaker (11).
18. Connect circuit 450A lead (12) to circuit breaker (13).
19. Install 450C lead (10) on bus bar (14). Secure with new lockwasher (15) and screw (16).
20. Install new grommet (17) and circuit 450 lead (18) in distribution box (3). Connect circuit 450 lead to circuit breaker (19).
21. Install new grommet (20) and circuit 2 lead (21) in distribution box (3).
22. Install new grommet (22) and circuit 2A lead (23) in distribution box (3).

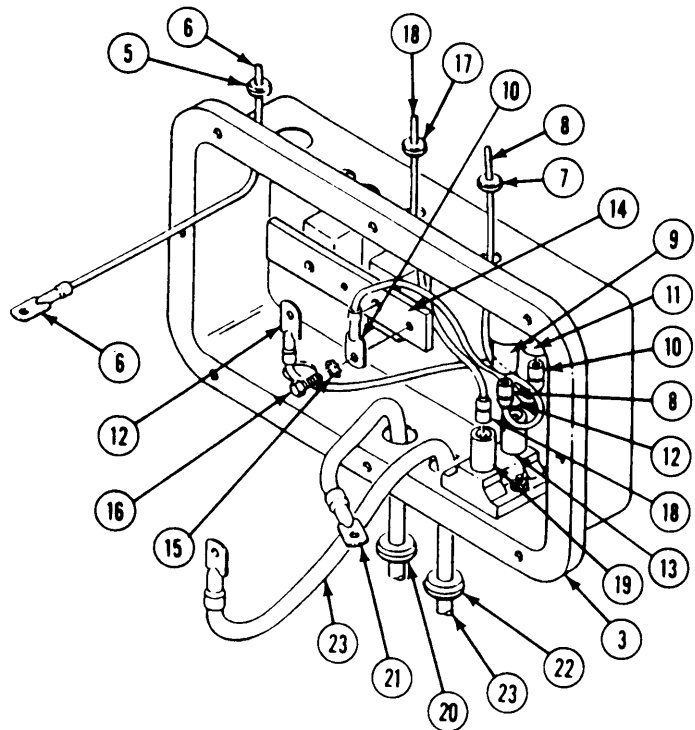

23. Install two new grommets (1 and 2), cable assembly W8 lead (3), and circuit 49 lead (4). Install circuit 49 lead (5) and cable assembly W8 leads (6 and 7) on bus bar (8). Secure with new lockwasher (9) and screw (10).
24. Install new grommet (11) and circuit 10, 14, 15, 27E lead (12) in distribution box (13). Install circuit 10, 14, 15, 27E lead (14) and circuit 450A lead (15) on bus bar (8). Secure with new lockwasher (16) and screw (17).
25. Install new grommet (18) and circuit 6 lead (19) in distribution box (13). Install circuit 6 lead (24) and cable assembly W8 leads (20 and 21) on bus bar (8). Secure with new lockwasher (22) and screw (23).
26. Apply one coat of adhesive to cleaned mounting surface of distribution box (13) and one side of new gasket (25).
27. Install new gasket (25) on coated mounting surface of distribution box (13).

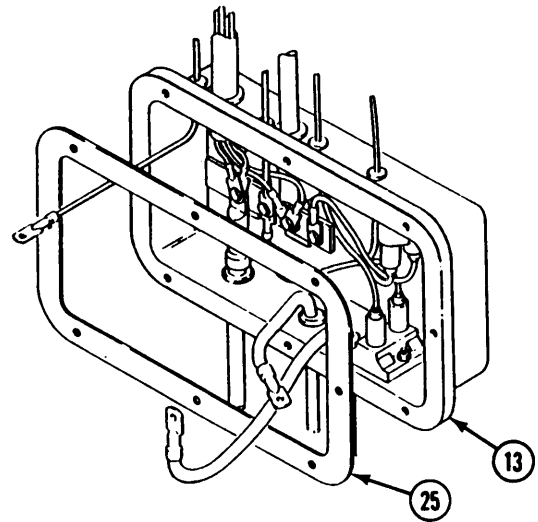
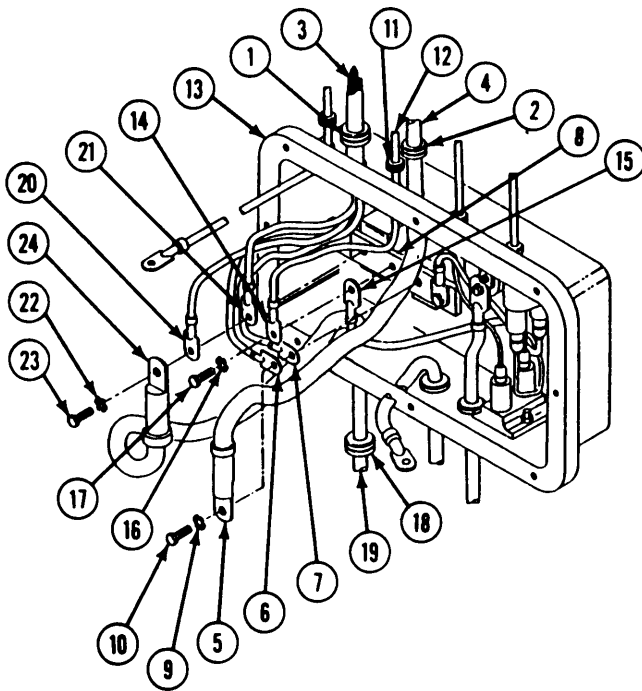

FOLLOW-TOUGH STEPS

1. Install Master Switch Panel (page 9-16).
2. Connect battery ground lead (page 13-2).
3. Start engine (see your -10). Check that distribution box works properly.
4. Shutdown engine (see your -10).

END OF TASK

**Section IV. MAINTENANCE OF STOPLIGHT, DOME LIGHTS,
BUZZER AND DOOR SWITCHES, AND TENT LIGHT**

TASK INDEX

<u>Task</u>	<u>Page</u>	<u>Task</u>	<u>Page</u>
Replace Stop Light-Tail Light and Guards (M981 and M1064 Only)	12-67	Replace Rear Dome Light Switch (M577A2 and M1068 Only)	12-69
Replace Dome Light (All Except M577A2 and M1068)	12-60	Replace Dome Light Circuit Breaker (M577A2 and M1068 Only)	12-70
Repair Dome Light (All Except M577A2 and M1068)	12-61	Replace Dome Blackout Light Bypass Switch (M577A2 and M1068 Only)	12-71
Replace Dome Light (M577A2 and M1068 Only)	12-64	Replace Admittance Buzzer and Switch (M577A2 and M1068 Only) . .	12-72
Repair Dome Light and Mount (M577A2 and M1068 Only)	12-65	Replace Ramp Door Switch and Mount (M577A2 and M1068 Only) . .	12-74
Replace Master Switch Panel Lead Assembly to Dome Lights (M577A2 and M1068 Only)	12-67	Replace Tent Light Assembly (M577A2 Only)	12-76
Replace Front Dome Light Switch (M577A2 and M1068 Only)	12-68	Replace Headlight High Beam Selector Switch	12-77

REPLACE STOP LIGHT-TAIL LIGHT AND GUARDS (M981 AND M1064 ONLY)

DESCRIPTION

This task covers : Remove (page 12-57). Install (page 12-58).

INITIAL SETUP

Tools:

General Mechanics Tool Kit (Item 30, App D)

Personnel Required:

Unit Mechanic

Materials/Parts:

- Gasket
- Lockwasher (8) (M1064)
- Lockwasher (6) (M981)

References:

See your -10

Equipment Conditions:

- Engine stopped/shutdown (see your -10)
- Carrier blocked (see your -10)

REMOVE

NOTE

Except for number of circuit leads and cable reel holder assembly (M1064), left and right stop light-tail lights and guards are removed and installed the same way.

Leads must be tagged so you will know how to install them.

1. On left stop light-tail light, disconnect circuit 21 lead (1), circuit 22 lead (2), and circuit 24 lead (3) from stop light-tail light (4).
2. On right stop light-tail light, disconnect circuit 24 lead (5) and circuit 23 lead (6) from stop light-tail light (7).

NOTE

Do step 3 for M1064 or step 4 for M981.

3. Remove two screws (8), lockwashers (9), washers (10), and holder assembly (11) from right external fuel tank and guard (12). Discard lockwashers.
4. Remove two screws (8), lockwashers (9), and washers (10) from right external fuel tank and guard (12). Discard lockwashers.
5. Remove two screws (13), lockwasher (14), washers (15), and guard (12) with stop light-tail light (7) from right external fuel tank.
6. Remove four screws (16), lockwashers (17), washers (18), and guard (19) with stop light-tail light (4) from left external fuel tank.

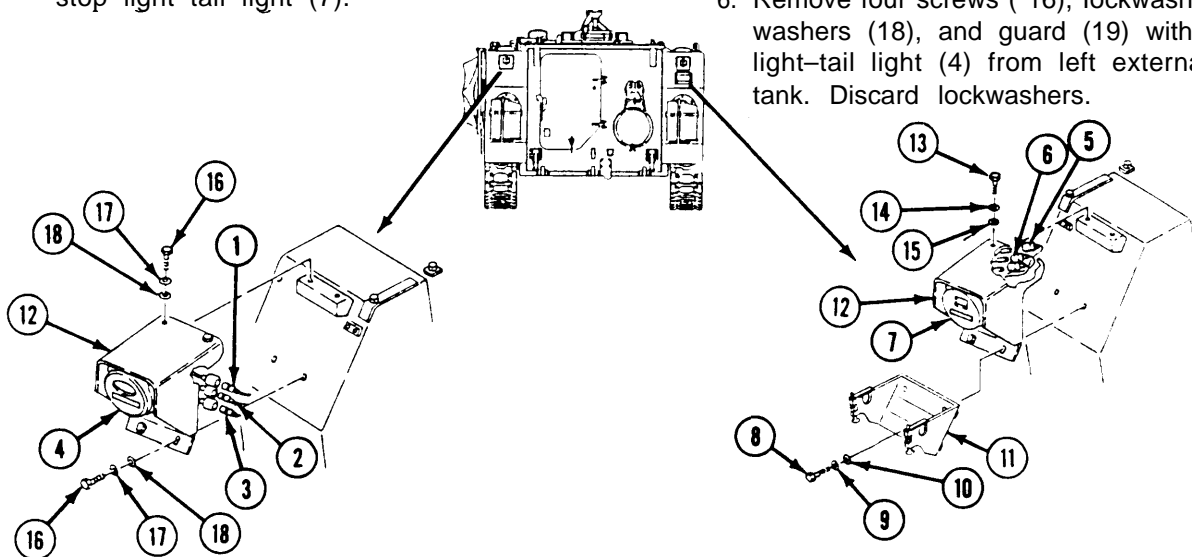

GO TO NEXT PAGE

7. Remove two screws (1), lockwashers (2), gasket (3), and stop light-tail light (4) from guard (5). Discard lockwashers and gasket.
8. If needed, remove two screws (6), lockwashers (7), washers (8), and guard (9) from fuel tank. Discard lockwashers.

INSTALL

11. If removed, place guard (17) on top deck. Secure with washer (16), new lockwasher (15), and screw (14).
12. If removed, place bracket (13) on fuel tank. Secure with two washers (12), new lockwashers (11), and screws (10).

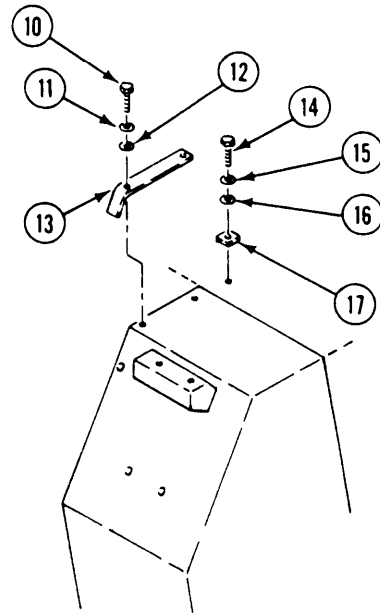
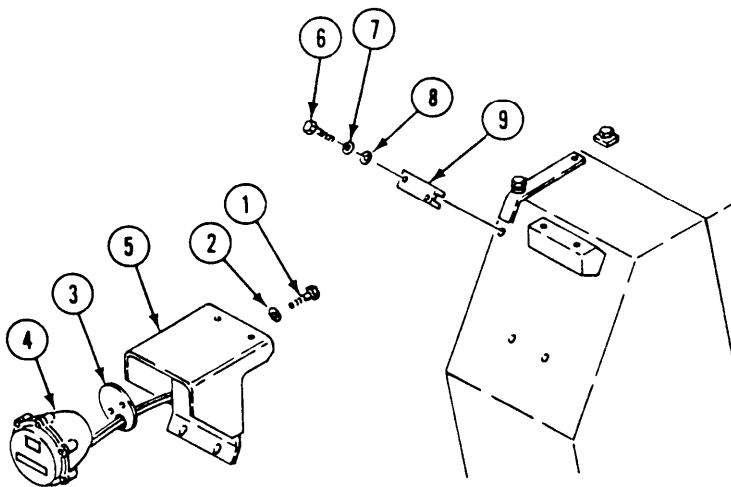

9. If needed, remove two screws (10), lockwashers (11), washers (12), and bracket (13) from fuel tank. Discard lockwashers.
10. If needed, remove screw (14), lockwasher (15), washer (16), and guard (17) from carrier top deck. Discard lockwashers.

13. If removed, place guard (9) on fuel tank. Secure with two washers (8), new lockwashers (7), and screws (6).
14. Place new gasket (3) and stop light-tail light (4) on guard (5). Secure with two new lockwashers (2) and screws (1).

15. Place guard (1) with stop light-tail light (2) on left fuel tank. Secure with four washers (3), new lockwashers (4), and screws (5).
16. Place guard (6) with stop light-tail light (7) on right fuel tank. Secure with two washers (8), new lockwashers (9), and screws (10).

19. On right stop Light-tail light, connect circuit 23 lead (15) and circuit 24 lead (16) to stop light-tail light (7).
20. On left stop light-tail light, connect circuit 24 lead (17), circuit 22 lead (18) and circuit 21 lead (19) to stop light-tail light (2).

NOTE

Do step 17 for M1064 or step 18 for M981.

17. Place holder assembly (11) on right fuel tank. Secure holder assembly (11) and guard (6) with two washers (12), new lockwashers (13), and screws (14).
18. Secure guard (6) with two washers (12), new lockwashers (13), and screws (14).

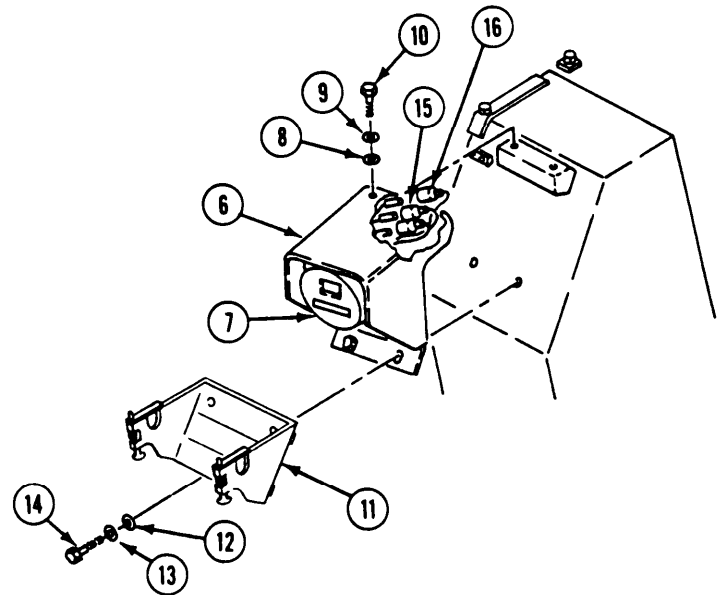
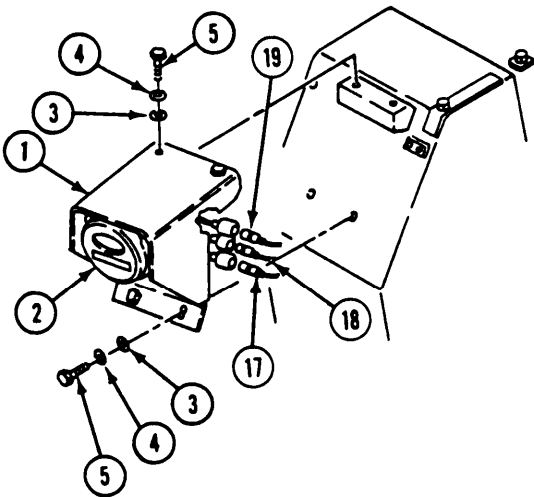

FOLLOW-THROUGH STEPS

1. Turn MASTER SWITCH ON (see your -10).
2. operate main light switches to check that left and right stop light-tail lights are operable (see your -10).
3. Turn all switches OFF (see your -10).

END OF TASK

REPLACE DOME LIGHT (ALL EXCEPT M577A2 AND M1068)

INITIAL SETUP

Tools:

General Mechanics Tool Kit (Item 30, App D)

Materials/Parts:

Lockwasher (4)

Personnel Required:

Unit Mechanic

References:

See your -10

Equipment Conditions:

Engine stopped/shutdown (see your -10)

Carrier blocked (see your -10)

Battery ground lead disconnected (page 13-2)

REMOVE

NOTE

Remove and install all dome lights the same way.

1. Disconnect circuit 38 lead (1) from rear of dome light (2).
2. Remove four screws (3), lockwashers (4), and dome light (2) from two mount brackets (5). Discard lockwashers.

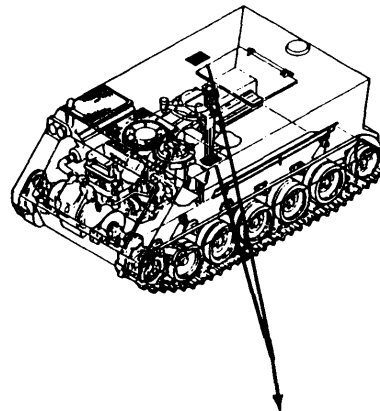

INSTALL

3. Place dome light (2) on two mount brackets (6). Slide four new lockwashers (4), one at a time, between dome light and mount bracket (5) and secure with screws (3).
4. Connect circuit 38 lead (1) to rear of dome light (2).

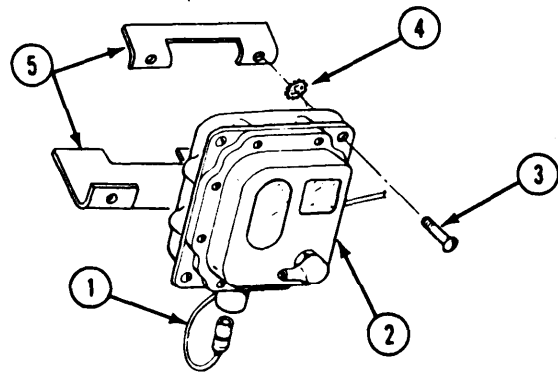

FOLLOW-THROUGH STEPS

1. Connect battery ground lead (page 13-2).
 2. Turn MASTER SWITCH ON (see your -10).
 3. Check that dome light operates properly (see your -10).
 4. Turn all switches OFF (see your -10).
-

END OF TASK

REPAIR DOME LIGHT (ALL EXCEPT M577A2 AND M1068)

DESCRIPTION

This task covers: Remove (page 12-61). Clean, Inspect, and Repair (page 12-62).
Install (page 12-62).

INITIAL SETUP

Tools:

General Mechanics Tool Kit (Item 30, App D)

Materials/Parts:

Lockwasher
Seal

Personnel Required:

Unit Mechanic

References:

see your -10

Equipment Conditions:

Engine stopped/shutdown (see your -10)
Carrier blocked (see your -10)
Dome light removed (page 12-60)

REMOVE

NOTE

If dome light retainer mounting screw separates from retainer, replace retaining clip.

1. Remove eight screws (1) and retainer (2) from dome light body (3).
2. Remove seal (4) from retainer (2). Discard seal.
3. Push in on light bulb (5) and blackout bulb (6) and turn to the left. Remove two bulbs.
4. Remove screws (7), lockwasher (8), and knob (9) from retainer (2). Discard lockwasher.
5. Remove nut (10), washer (11), gasket (12), and switch (13) from retainer (2).
6. Remove setscrew (14), plunger (15), and plunger (16) from knob (9).
7. Remove lens (17) and gasket (18) from retainer (2).
8. Remove lens (19) from retainer (2).

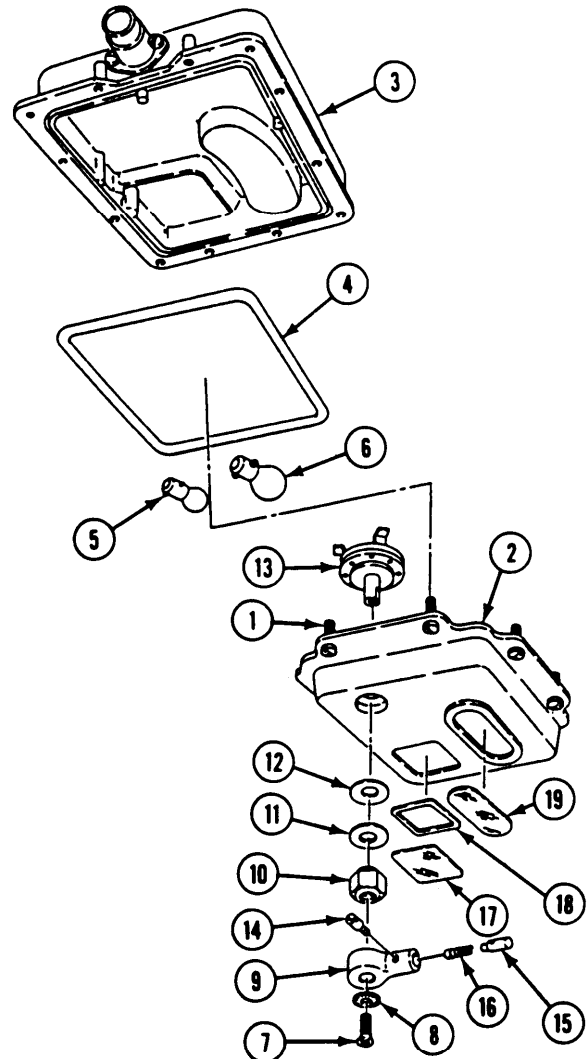

GO TO NEXT PAGE

CLEAN, INSPECT, AND REPAIR

9. Check all light bulbs for damage and replace where needed.
10. Check lenses, gaskets, and all other parts for damage. Replace all damaged parts.

INSTALL

11. Install lens (1) and lens (2) with gasket (3) on retainer (4).
12. Install plunger (5) with plunger (6) in knob (8) and secure with setscrew (7).
13. Install stitch (9) through retainer (4). Install gasket (10) and washer (11) on switch (9) and secure with nut (12).
14. Install knob (8), new lockwasher (13), and screw (14) on switch (9).
15. Install blackout bulb (15) and Light bulb (16) in light body (17). Push in and turn bulbs to the right to secure.
16. Install new seal (18) on retainer (4).
17. Place retainer (4) on light body (17). Secure with eight screws (19).

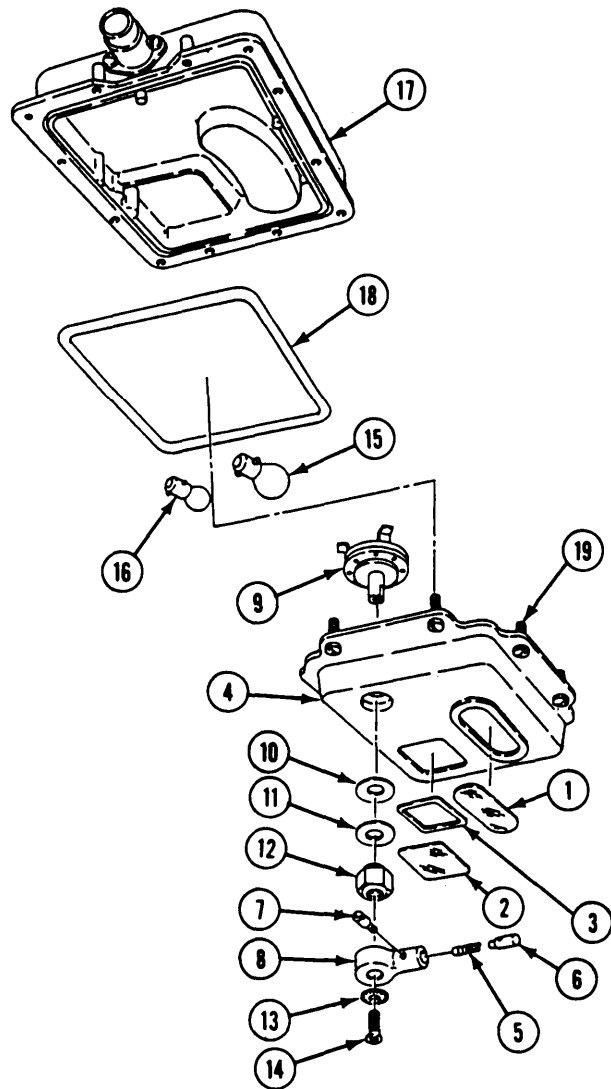

FOLLOW-THROUGH STEPS

1. Install dome light (page 12-60).
2. Turn MASTER SWITCH ON (see your -10). Check dome lights for proper operation.
3. Turn MASTER SWITCH OFF (see your -10).

END OF TASK

REPLACE REAR DOME LIGHT LEAD (M741A1 ONLY)

INITIAL SETUP

Tools:

General Mechanics Tool Kit (Item 30, App D)

References:

see your -10

Materials/Parts:

Tape (Item 26, App C)

Equipment Conditions:

Engine stopped/shutdown (see your -10)

Carrier blocked (see your -10)

Battery ground lead disconnected (page 13-2)

Personnel Required:

Unit Mechanic

REMOVE

1. Remove tape that holds circuit 38 lead (1) to adjacent electrical leads.
2. Disconnect lead (1) from rear of dome light (2) and rear main wiring harness (3).
3. Pull lead (1) from five support brackets (4). Remove lead from carrier.

INSTALL

4. Route circuit 38 lead (1) through five support brackets (4).
5. Connect lead (1) to rear main wiring harness (3) and rear dome light (2).
6. Connect lead (1) to adjacent electrical leads with tape, use three one-half overlapping turns at 7-8 inch (18-20 cm) intervals.

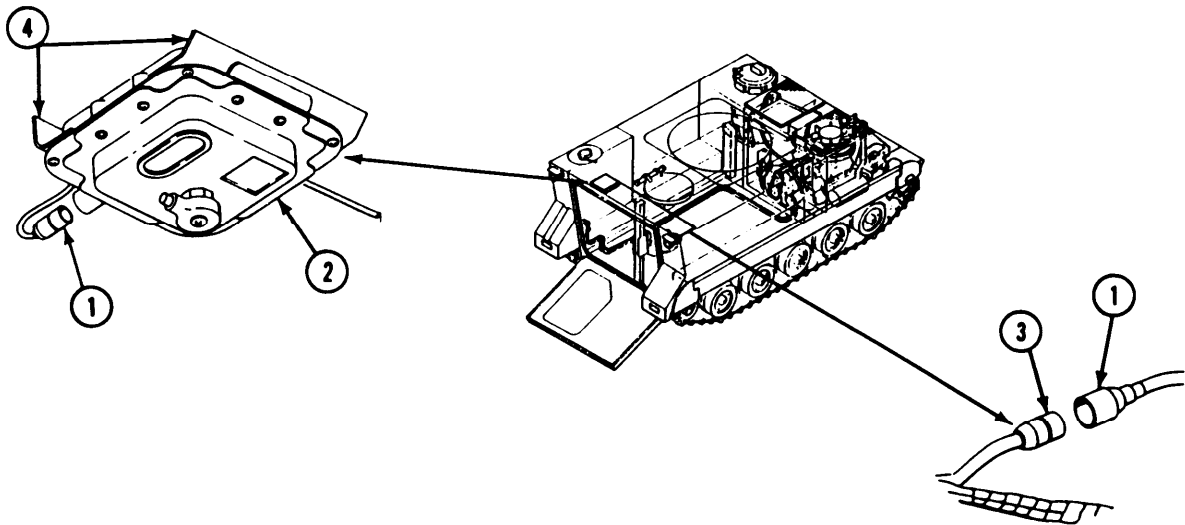

FOLLOW-THROUGH STEPS

1. Connect battery ground lead (page 13-2)
 2. Turn MASTER SWITCH ON. Operate rear dome light to check that light operates properly.
 3. Turn au switches OFF (see your -10).
-

END OF TASK

REPLACE DOME LIGHT (M577A2 AND M1068 ONLY)

INITIAL SETUP

Tools:

General Mechanics Tool Kit (Item 30, App D)

Materials/Parts:

Lockwasher (4)

Personnel Required:

Unit Mechanic

References

See your -10

Equipment Conditions:

Engine stopped/shutdown (see your -10)

REMOVE

NOTE

There are nine dome lights and two blackout lights in the M577A2 and M1068. Remove and install all lights the same way.

1. Disconnect ground lead (1) from dome light (2).
2. Disconnect lead (3) from dome light (2).

NOTE

Disconnect circuit 38C lead from dome lights or circuit 38B lead from blackout lights.

3. Loosen screw (4). Lower door (5) on dome light (2).
4. Remove four nuts (6), lockwashers (7), screws (8), and light (2) from mount (9). Discard lockwashers.

INSTALL

5. Place light (2) on mount (9). Secure with four screws (8), new lockwashers (7), and nuts (6).
6. Close door (5) on light (2). Secure with screw (4).

7. Connect lead (3) to light (2).

NOTE

Connect circuit 38C lead to dome lights or circuit 38B lead to blackout lights.

8. Connect ground lead (1) to dome light (2).

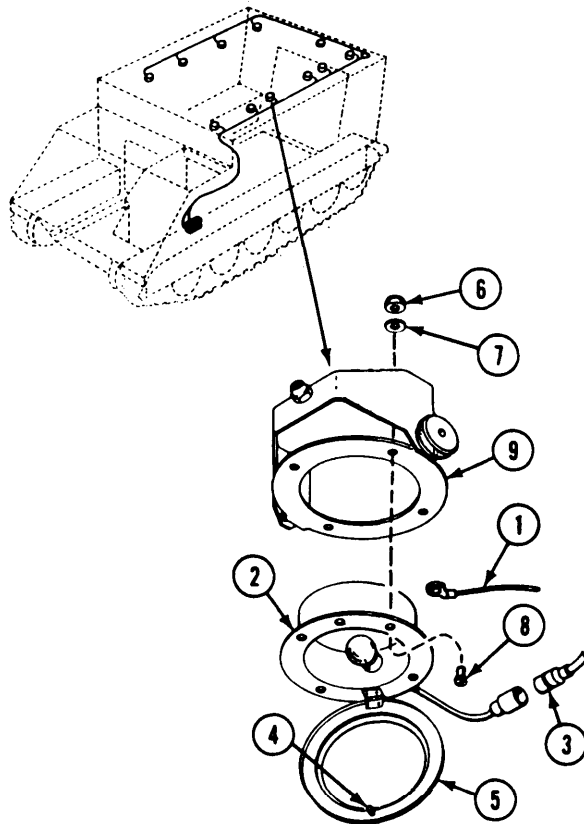

FOLLOW-THROUGH STEPS

1. Turn MASTER SWITCH ON (see your -10).
2. Operate dome light or blackout light to check that light operates properly (see your -10).
3. Turn all switches OFF (see your -10).

END OF TASK

REPAIR DOME LIGHT AND MOUNT (M577A2 AND M1068 ONLY)

DESCRIPTION

This task covers: Disassemble (page 12-65). Clean, Inspect, and Repair (page 12-66). Assemble (page 12-66).

INITIAL SETUP

Tools:

General Mechanics Tool Kit (Item 30, App D)

References:

see your -10

Materials/Parts:

Sealing Compound (Item 52, App C)
Self-locking nut (6)

Equipment Conditions:

Engine stopped/shutdown (see your -10)
Dome light removed (page 12-64)

Personnel Required:

Unit Mechanic

DISASSEMBLE

1. To disassemble dome light, do the following:

NOTE

Disassemble and assemble dome lights and blackout lights the same way. Lens in dome light is clear. Lens in blackout light is dark (nine dome lights, two blackout lights).

- a. Remove lens (1) and seal (2) from light door (3).
- b. Push in and turn lamp (4) to the left. Remove lamp lamp light body (5).

2. To disassemble dome light mount, do the following

- a. Remove knob (6), nut (7), two small washers (8), two large gaskets (9), and mount plate (10) from bracket (11).
- b. Remove two large gaskets (9) from plate (10).
- c. Remove six locknuts (12), three washers (13), mount (14), and bracket (11) from hull mounts (15). Discard locknuts.

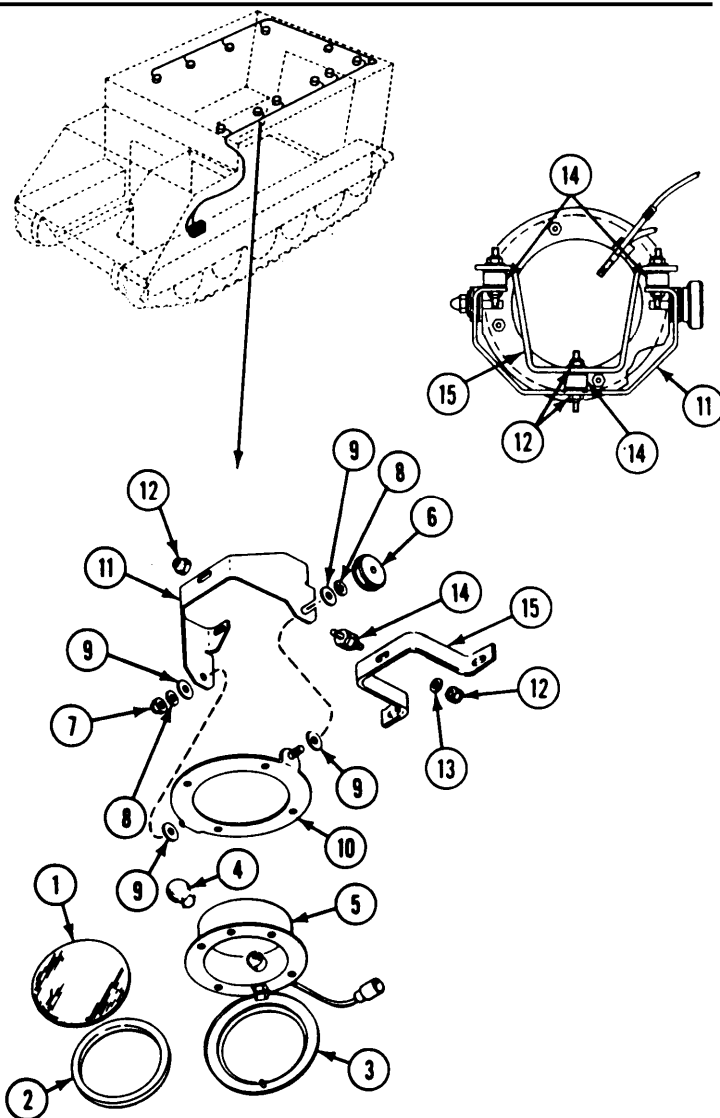

GO TO NEXT PAGE

CLEAN, INSPECT, AND REPAIR

3. Check lamp. Replace burned-out or cracked lamp.
4. Check lens. Replace cracked or chipped lens.
5. Check seal and mounts. Replace cut, cracked, or hard seal and mounts.
6. Check plate and bracket. Replace any cracked or deformed parts.
7. Check threaded parts. Remove burrs. Replace parts that have stripped threads.

ASSEMBLE

8. To assemble dome light mount, do the following:
 - a. Install three mounts (1) between bracket (2) and hull mount (3). Secure with six new locknuts (4) and three washers (6).
 - b. Place two large gaskets (6) on mount plate (7). Install plate on bracket (2). Secure with two large gaskets (6), small washers (8), nut (9), and knob (10).
9. To assemble dome light, do the following:
 - a. Install lamp (11) in light body (12). Push in and turn to the right to secure lamp.
 - b. Apply sealing compound to inside of door (13). Install seal (14) and lens (15) on door.

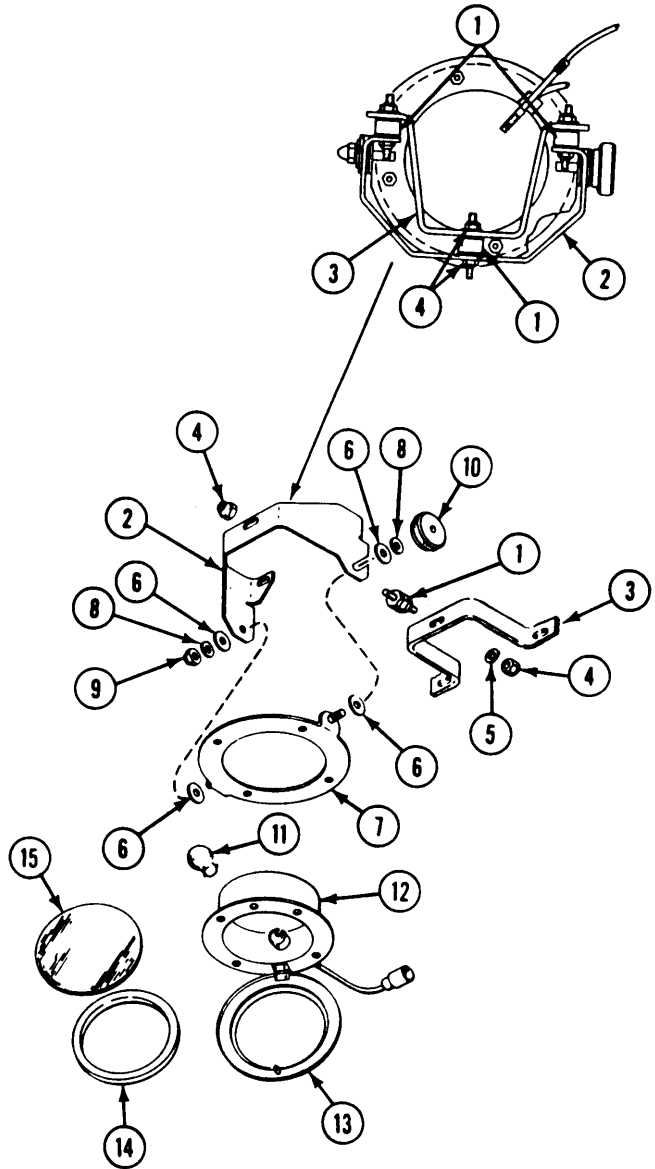

FOLLOW-THROUGH STEPS

1. Install dome light (page 12-64).
-

END OF TASK

REPLACE MASTER SWITCH PANEL LEAD ASSEMBLY TO DOME LIGHTS (M577A2 AND M1068 ONLY)

INITIAL SETUP

Tools:

General Mechanics Tool Kit (Item 30, App D)

References:

see your -10

Materials/Parts:

Gasket
Grommet
Self-locking nut (8)

Equipment Conditions:

Engine stopped/shutdown (see your -10)
Carrier blocked (see your -10)
Battery ground lead disconnected (page 13-2)

Personnel Required:

Unit Mechanic

REMOVE

1. Remove eight locknuts (1), washers (2), screws (3), and master switch panel (4) from distribution box (5). Discard locknuts.
2. Disconnect lead assembly (6) from front dome light switch (7), circuit breaker (8), and circuit 38E lead (9).
3. Pull lead assembly (6) with grommet (10) from master switch panel (4). Discard grommet.
4. Inspect gasket (11). Replace if damaged.

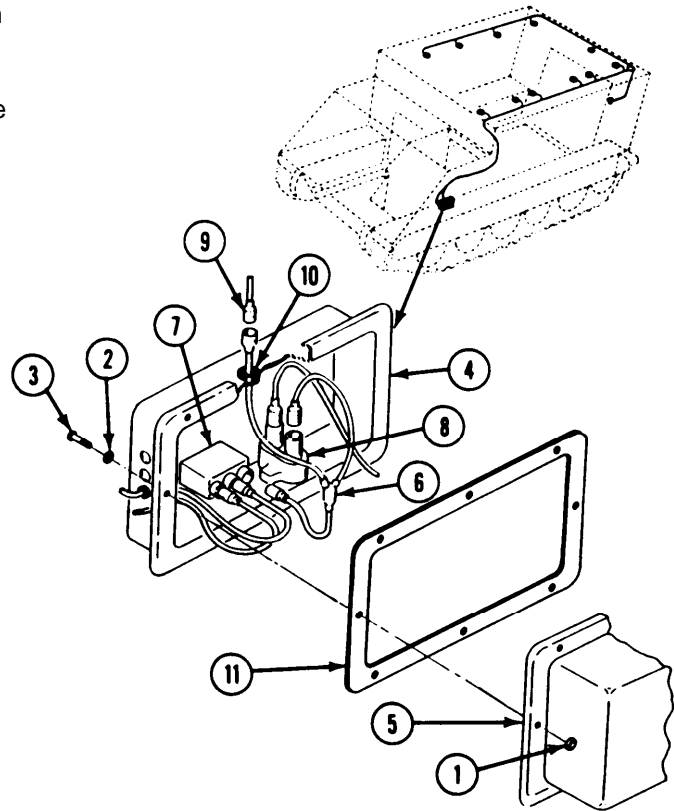

INSTALL

5. Place new grommet (10) on branch of lead assembly (6) that connects to circuit 38E lead (9).
6. Install lead assembly (6) with grommet (10) in master switch panel (4).
7. Connect lead assembly (6) to circuit 38E lead (9), circuit breaker (8), and front dome light switch (7).

FOLLOW-THROUGH STEPS

1. Connect battery ground lead (page 13-2).
2. Turn MASTER SWITCH ON.
3. Operate dome lights to check that lights operate properly (see your -10).
4. Turn all switches OFF (see your -10).

END OF TASK

REPLACE FRONT DOME LIGHT SWITCH (M577A2 AND M1068 ONLY)

INITIAL SETUP

Tools:

General Mechanics Tool Kit (Item 30, App D)

References:

see your -10

Materials/Parts:

Gasket
Self-locking nut (8)

Equipment Conditions:

Engine stopped/shutdown (see your -10)
Battery ground lead disconnected (page 13-2)

Personnel Required:

Unit Mechanic

REMOVE

1. Remove eight locknuts (1), washers (2), screws (3), and master switch panel (4) from distribution box (5). Discard locknuts.
2. Disconnect circuit 38 lead (6), circuit 38A lead (7), and circuit 10 lead (8) from rear of front dome light switch (10).
3. Remove two screws (9) and switch (10) from master switch panel (4).
4. Inspect gasket (11). Replace if damaged.

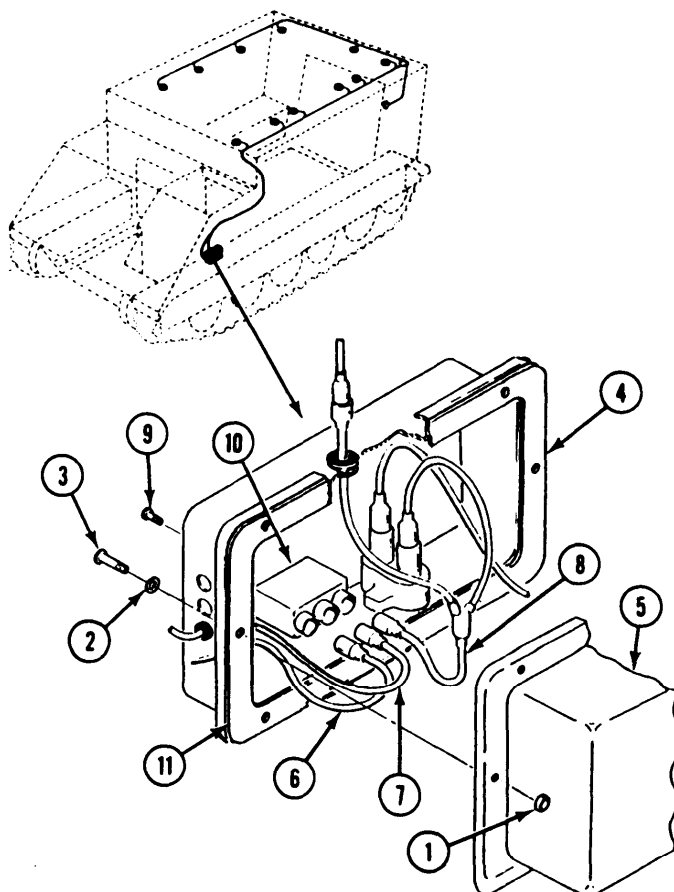

INSTALL

5. Place switch (10) in master switch panel (4). Secure with two screws (9).
6. Connect circuit 10 lead (8), circuit 38A lead (7), and circuit 38 lead (6) to rear of dome light switch (10).
7. Place panel (4) on distribution box (5). Secure with eight screws (3), washers (2), and new locknuts (1).

FOLLOW-THROUGH STEPS

- | | |
|--|---|
| <ol style="list-style-type: none"> 1. Connect battery ground lead (page 13-2). 2. Turn MASTER SWITCH ON. | <ol style="list-style-type: none"> 3. Turn on front dome light switch to check that switch is operable. Dome light should come on. 4. Turn all switches OFF (see your -10). |
|--|---|

END OF TASK

REPLACE REAR DOME LIGHT SWITCH (M577A2 AND M1068 ONLY)

INITIAL SETUP

Tools:

General Mechanics Tool fit (Item 30, App D)

Personnel Required:

Unit Mechanic

References:

See your -10

Equipment Conditions:

Engine stopped/shutdown (see your -10)
Battery ground lead disconnected (page 13-2)

REMOVE

1. Disconnect circuit 38 lead (1), circuit 38A lead (2), and circuit 38E lead (3) from back of rear dome light switch (5).
2. Remove two screws (4) and switch (5) from hull bracket.

INSTALL

3. Place switch (5) on hull bracket. Secure with two screws (4).
4. Connect circuit 38E lead (3), circuit 38A lead (2), and circuit 38 lead (1) to back of switch.

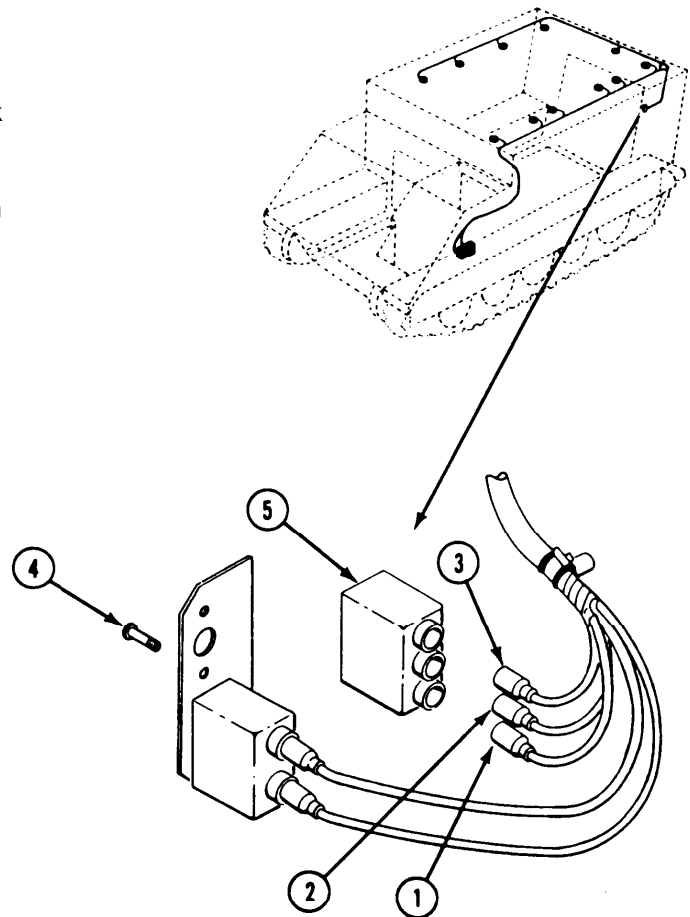

FOLLOW-THROUGH STEPS

1. Connect battery ground lead (page 13-2).
 2. Turn MASTER SWITCH ON (See your -10).
 3. Turn REAR DOME LIGHT SWITCH ON (see your -10). Check that switch operates properly. Dome light should come on.
 4. Turn all switches OFF (see your -10).
-

END OF TASK

REPLACE DOME LIGHT CIRCUIT BREAKER (M577A2 AND M1068 ONLY)

INITIAL SETUP

Tools:

General Mechanics Tool Kit (Item 30, App D)

Materials/Parts:

Gasket
Self-locking nut (8)

Personnel Required:

Unit Mechanic

References:

See your -10

Equipment Conditions:

Engine stopped/shutdown (see your -10)
Battery ground lead disconnected (page 13-2)

REMOVE

1. Remove eight locknuts (1), washers (2), screws (3), and master switch panel (4) from distribution box (5). Discard locknuts.
2. Disconnect two circuit 10 leads (6) from circuit breaker (7).
3. Remove two nuts (8), screws (9), and circuit breaker (7) from master switch panel (4).
4. Inspect gasket (10). Replace if damaged.

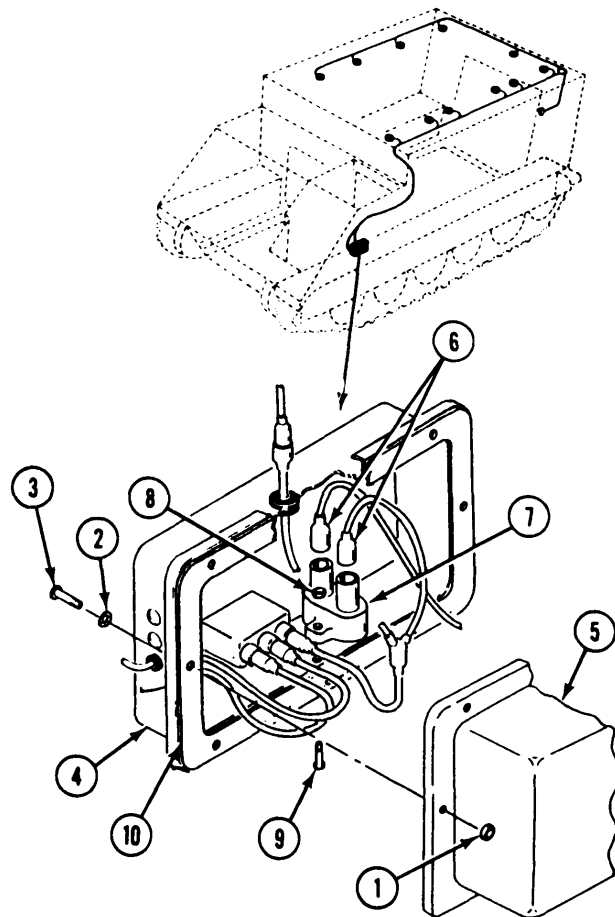

INSTALL

5. Place circuit breaker (7) in master switch panel (4). Secure with two screws (9) and nuts (8).
6. Connect two circuit 10 leads (6) to circuit breaker (7).
7. Place master switch panel (4) on distribution box (5). Secure with eight screws (3), washers (2), and new locknuts (1).

FOLLOW-THROUGH STEPS

1. Connect battery ground lead (page 13-2).
2. Turn MASTER SWITCH ON. Operate dome lights to check that circuit breaker is operable. Turn all switches OFF (see your -10).

END OF TASK

REPLACE DOME BLACKOUT LIGHT BYPASS SWITCH (M577A2 AND M1068 ONLY)

INITIAL SETUP

Tools:

General Mechanics Tool Kit (Item 30, App D)

References:

see your -10

Personnel Required:

Unit Mechanic

Equipment Conditions:

Engine stopped/shutdown (see your -10)

REMOVE

1. Disconnect circuit 38B lead (1) and circuit 38E lead (2) from rear of bypass switch (3).
2. Remove two screws (4) and switch (3) from hull bracket.

INSTALL

3. Place switch (3) on hull bracket. Secure with two screws (4).
4. Connect circuit 38E lead (2) and circuit 38B lead (1) to rear of bypass switch (3).

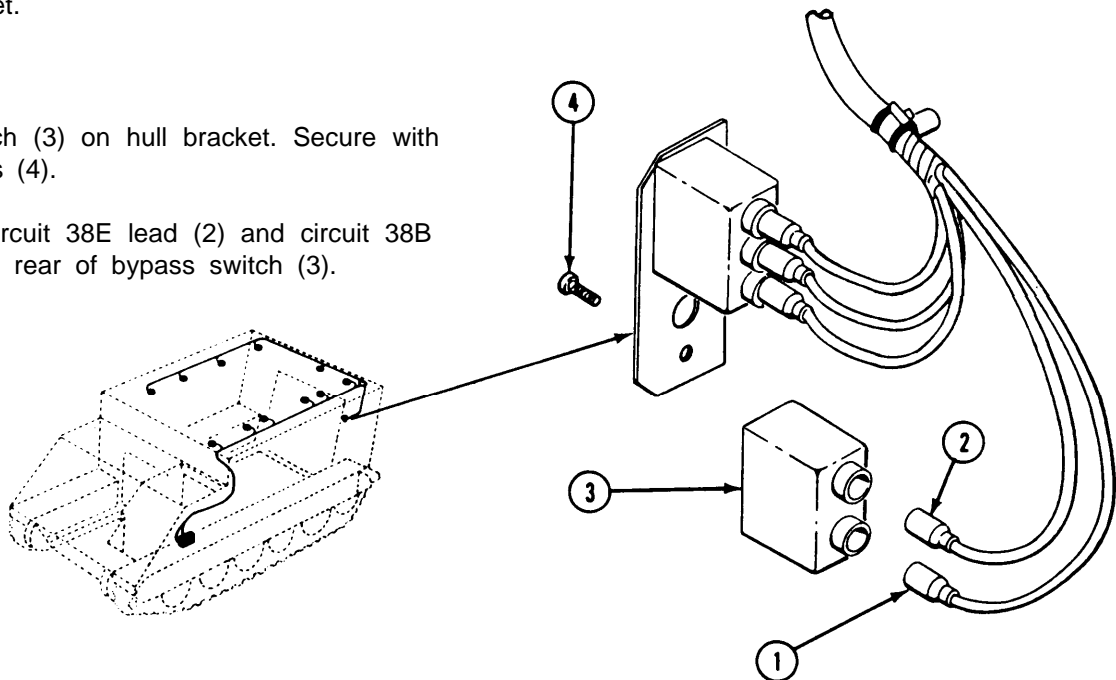

FOLLOW-THROUGH STEPS

1. Turn MASTER SWITCH ON (see your -10).
 2. Operate dome lights and bypass switch to check that switch operates properly (see your -10).
 3. Turn all switches OFF (see your -10).
-

END OF TASK

REPLACE ADMITTANCE BUZZER AND SWITCH (M577A2 AND M1068 ONLY)

DESCRIPTION

This task covers: Remove (page 12-72). Clean, Inspect, and Repair (page 12-72).
Install (page 12-73).

INITIAL SETUP

Tools:

General Mechanics Tool Kit (Item 30, App D)

References:

See your -10

Materials/Parts:

Gasket
Lockwasher (3)

Equipment Conditions:

Engine stopped/shutdown (see your -10)
Battery ground lead disconnected (page 13-2)

Personnel Required:

Unit Mechanic

REMOVE

1. Disconnect circuit 509 lead (1) from buzzer (4) and buzzer switch (7).
2. Remove three screws (2), lockwashers (3) and buzzer (4) from weldnuts on left bulkhead. Discard lockwashers.
3. Remove nut (5), gasket (6), and buzzer switch (7) from rear bulkhead. Discard gasket.

CLEAN, INSPECT, AND REPAIR

4. Check buzzer and switch. See troubleshooting (page 3-126). Replace bad switch.

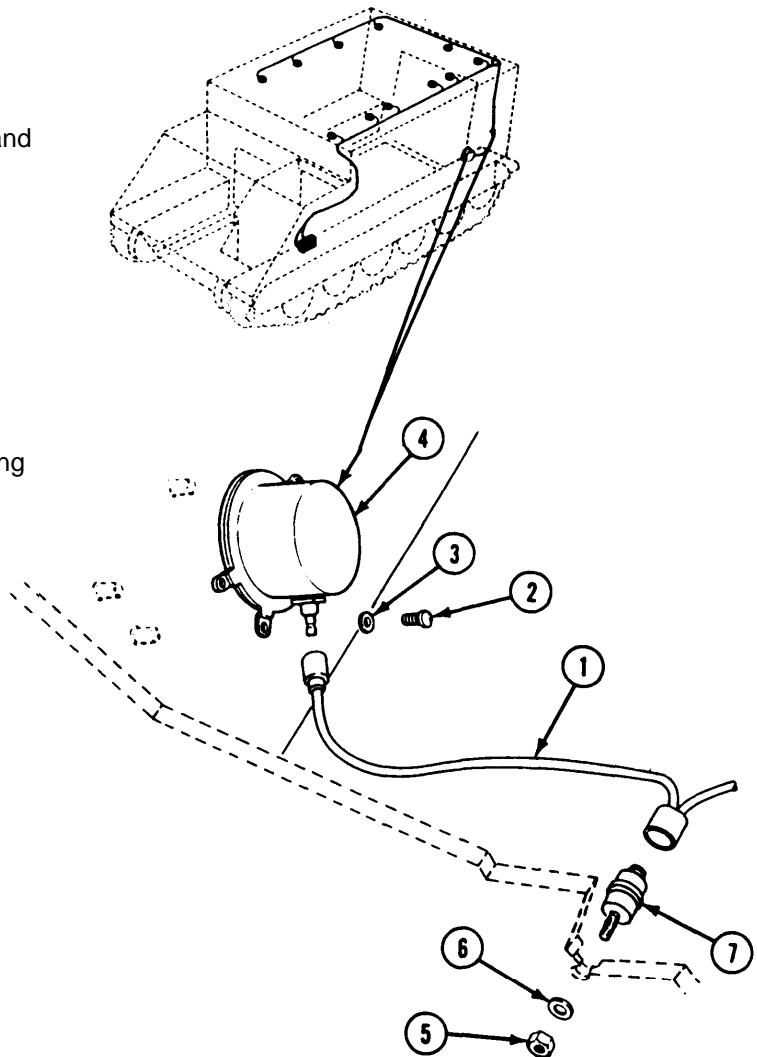

INSTALL

NOTE

Switch comes with two nuts and two washers. When installing new switch, remove and discard one lockwasher and one nut before installation.

5. Install buzzer switch (7) in rear bulkhead. Secure with new gasket (6) and nut (5).
6. Place buzzer (4) on weldnuts on left bulkhead. Secure with three screws (2) and new lockwashers (3).
7. Connect circuit 509 lead (1) to buzzer (4) and buzzer switch (7).

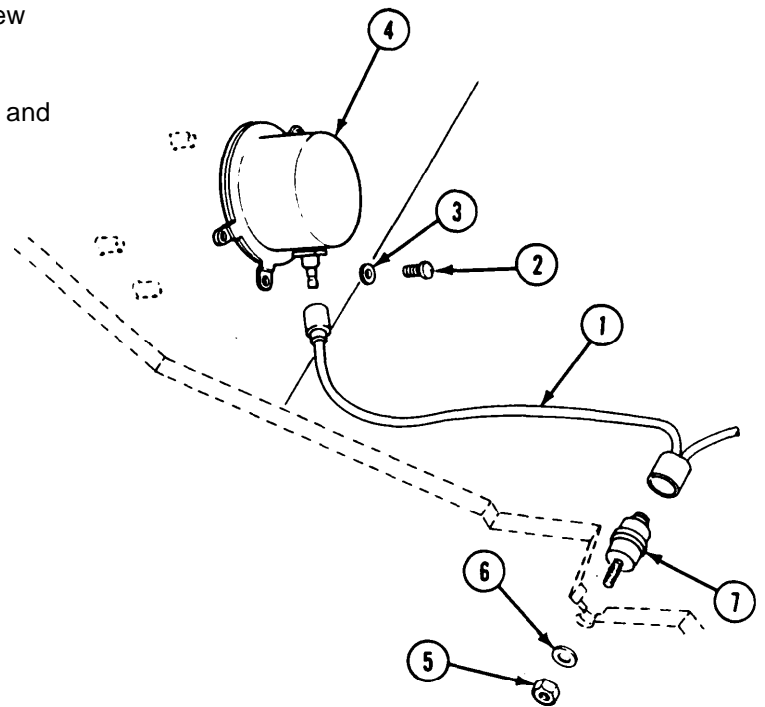

FOLLOW-THROUGH STEPS

1. Connect battery ground lead (page 13-2).
2. Turn MASTER SWITCH ON (see your -10).
3. Operate buzzer switch to check that switch operates properly. Turn MASTER SWITCH OFF (see your -10).

END OF TASK

REPLACE RAMP DOOR SWITCH AND MOUNT (M577A2 AND M1068 ONLY)

DESCRIPTION

This task covers: Remove (page 12-74). Clean and Inspect (page 12-74).
Install (page 12-74). Adjust (page 12-75).

INITIAL SETUP

Tools:

General Mechanics Tool Kit (Item 30, App D)

Materials/Parts:

Self-locking nut (4)
Self-locking nut

Personnel Required:

Unit Mechanic

References

See your -10

Equipment Conditions

Engine stopped/shutdown (see your -10)
Battery ground lead disconnected (page 13-2)
Carrier blocked (see your -10)

REMOVE

1. Disconnect circuit 38 lead (1), circuit 38B lead (2), and circuit 38C lead (3) from switch (4).
2. Remove locknut (5), screw (6), and retainer (7) from actuator (8). Discard locknut.
3. Remove switch (4) from actuator (8).
4. Remove two locknuts (10), washers (11), screws (12), and actuator (8) from bracket (9). Discard locknuts.
5. Remove two locknuts (13), screws (14), and bracket (9) from hull. Discard locknuts.

8. Place actuator (8) on bracket (9). Secure with two screws (12), washers (11), and new locknuts (10). Do not tighten screws.
9. Place switch (4) on actuator (8). Secure with retainer (7), screw (6), and new locknut (5).
10. Connect circuit 38C lead (3), circuit 38B lead (2), and circuit 38 lead (1) to switch (4).

CLEAN AND INSPECT

6. Check for cracks or other damage to switch. If damaged, replace switch.

NOTE

Steps 11 through 16 tell you how to adjust switch before tightening nuts at installation procedure.

INSTALL

7. Place bracket (9) on hull. Secure with two screws (14) and new locknuts (13).

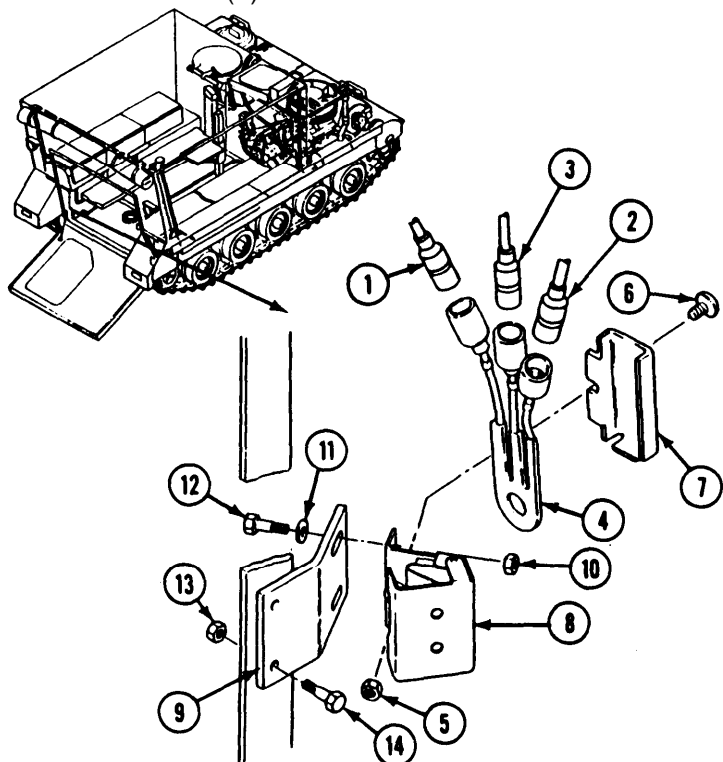

ADJUST

11. Connect battery ground lead (page 13-2).
12. Raise and lock ramp (see your -10).
13. Loosen two screws (1) and slide switch (2) as far as possible horn hull.
14. Lock ramp door handle (3) against stop (4) (see position 1 in illustration).
15. Slide switch (2) against handle (3) to get approximately 1/4 inch (7 mm) clearance. Tighten screws (1).
16. Move handle (3) against detent (5) (see position 2 in illustration). Clearance should be approximately 5/8 inch (16 mm). From this setting, check switch for proper function. Interior lights (white) should come on and blue light should be off. When handle (3) is in first position (see illustration) interior lights (white) should be off and blue lights should be on. Do steps 13 thru 16 and make adjustments until the switch function produces the correct result as stated herein.

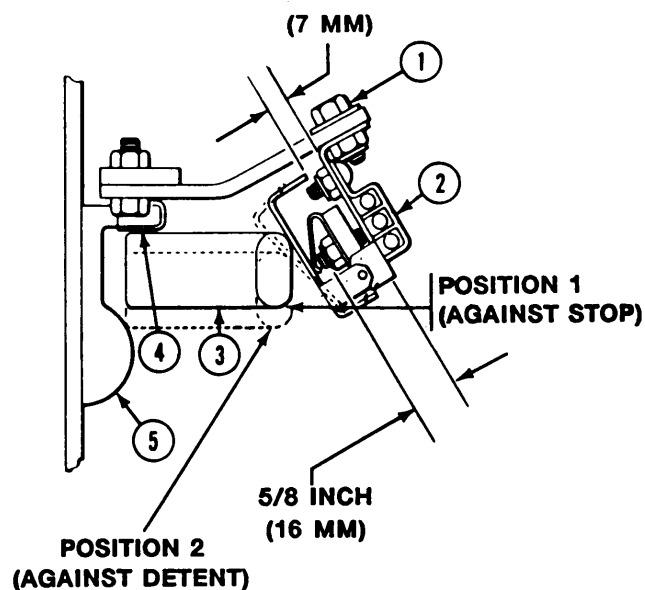
**FOLLOW-THROUGH STEPS**

1. Turn MASTER SWITCH ON (see your -10).
2. Turn on dome lights and open ramp access door. All dome lights should go off and blackout lights should come on.
3. Turn all switches OFF' (see your -10).
4. Turn MASTER SWITCH OFF (See your -10).

END OF TASK

REPLACE TENT LIGHT ASSEMBLY (M577A2 ONLY)

INITIAL SETUP

Tools:

General Mechanics Tool Kit (Item 30, App D)

References:

See your -10

Materials/Parts:

Incandescent lamp

Equipment Conditions:

Engine stopped/shutdown (see your -10)

Carrier blocked (see your -10)

Battery ground lead disconnected (page 13-2)

Personnel Required:

Unit Mechanic

REMOVE

1. Remove connector (1) from utility outlet receptacle (2) on rear bulkhead.
2. Remove light assembly (3) from tent supports.
3. Push in on lamp (4) and turn to the left. Remove lamp from light assembly. Discard lamp.

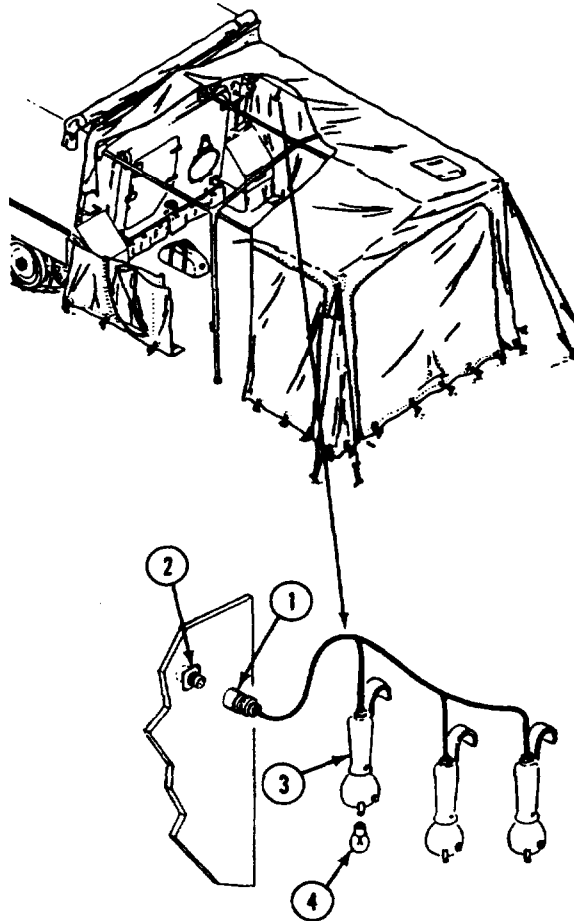

INSTALL

4. Install new lamp (4) in light assembly (3). Push in and turn to the right to secure lamp.
5. Hang light assembly (3) on tent supports.
6. Install connector (1) on utility outlet receptacle (2).

FOLLOW-THROUGH STEPS

1. Connect battery ground lead (page 13-2).
 2. Turn MASTER SWITCH ON (see your -10).
 3. Check that tent lamps operate properly (see your -10).
 4. Turn MASTER SWITCH OFF (see your -10).
-

END OF TASK

REPLACE HEADLIGHT HIGH BEAM SELECTOR SWITCH

INITIAL SETUP

Tools:

General Mechanics Tool Kit (Item 30, App D)

Materials/Parts:

Lockwashers (2)

Personnel Required:

Unit Mechanic

References

see your -10

Equipment Conditions:

Engine stopped/shutdown (see your -10)
Carrier blocked (see your -10)

REMOVE

1. From driver's compartment, remove two screws (1) and lockwashers (2) from bracket (3). Discard lockwashers.
2. Remove switch (4) from bracket (3).
3. Disconnect cable (5) from rear of light beam selector switch (4).

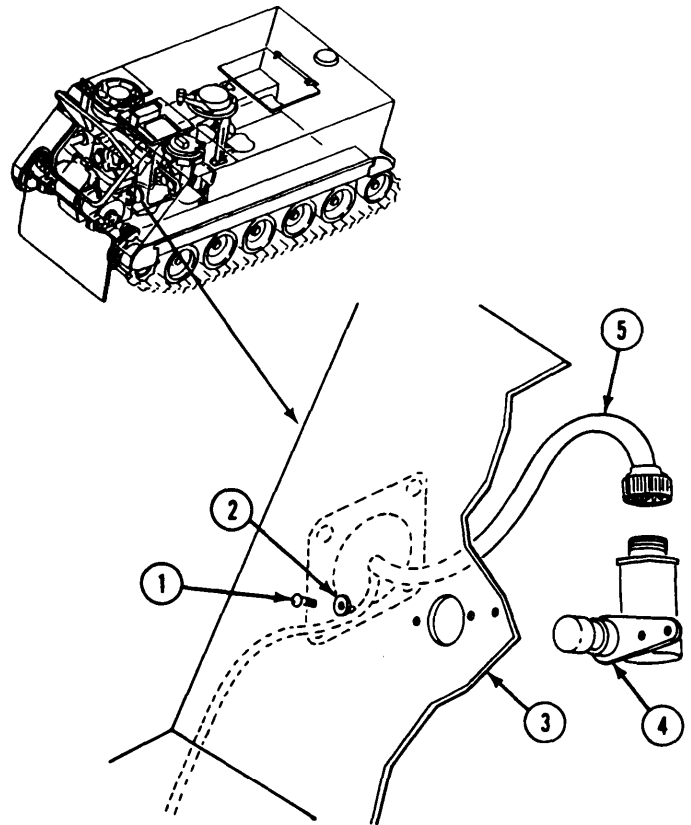

INSTALL

4. Connect cable (5) to rear of switch (4).
5. Install switch (4) in bracket (3).
6. Secure switch (4) to bracket (3) with two new lockwashers (2) and screws (1).

FOLLOW-THROUGH STEPS

1. Turn MASTER SWITCH ON (See your -10).
2. Turn on service headlights and operate beam selector switch to check that switch operates properly (see your -10).
3. Turn all switches OFF (see your -10).
4. Turn MASTER SWITCH OFF (see your -10).

END OF TASK

Section V. MAINTENANCE OF WIRING HARNESS

TASK INDEX

<u>Task</u>	<u>Page</u>	<u>Task</u>	<u>Page</u>
Replace Right Headlight Wiring Harness	12-79	Replace Rear Main Wiring Harness (M1064 Only)	12-118.1
Replace Rear Main Wiring Harness (M577A2 and M1068 Only)	12-82	Replace Rear Main Wiring Harness (M113A2, M901A1, and M1059 Only)	12-119
Replace Rear Main Wiring Harness (M106A2 and M125A2 Only)	12-106		

REPLACE RIGHT HEADLIGHT WIRING HARNESS

DESCRIPTION

This task covers: Remove (page 12-79). Clean, Inspect, and Repair (page 12-80).
Install (page 12-80).

INITIAL SETUP

Tools:

General Mechanics Tool Kit (Item 30, App D)
Digital Multimeter (Item 43, App D)
Electrical Tool Kit (Item 75, App D)

Materials/Parts:

Insulation tape (Item 26, App C)
Lockwasher (4)
Terminal (6)

Personnel Required:

Unit Mechanic

References:

See your -10

Equipment Conditions:

Engine stopped/shutdown (see your -10)
Carrier blocked (see your -10)
Trim vane lowered (see your -10)
Power plant front access door open
(see your -10)
Power plant grill raised (page 5-2)
Battery ground lead disconnected (page 13-2)

REMOVE

1. Disconnect right headlight wiring harness (1) from front main wiring harness (2) at driver's compartment bulkhead.
2. Disconnect circuits 514 and 515 leads (3 and 4) from right infrared headlight (5).
3. Disconnect circuit 25 lead (6) from horn (7).
4. Disconnect circuit 20 lead (8) from right blackout marker light (9).
5. Disconnect circuits 17, and 18 leads (10 and 11) from right service headlight (12).

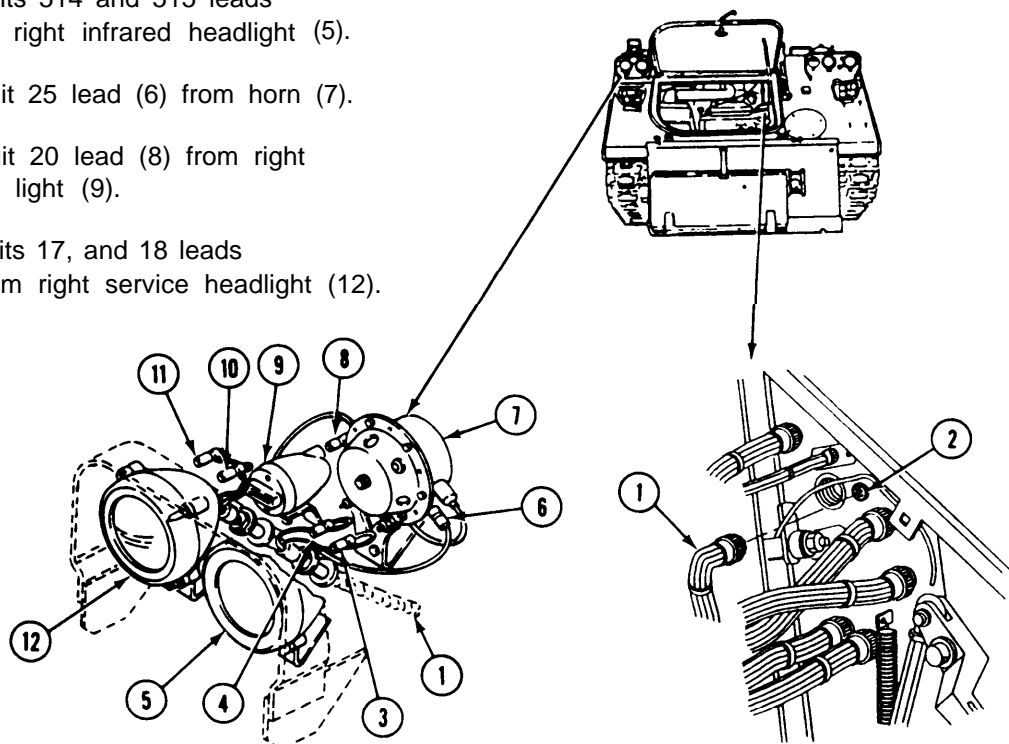

GO TO NEXT PAGE

6. Remove six terminals (1), insulators (2), and connectors (3) from six leads disconnected in steps 1 through 5. Discard terminals. Remove tape from leads 17 and 18 (4 and 5).
7. Remove bushing (6), retainer (7), and spring washer (8), from coupling (9).
8. Remove four nuts (10), lockwashers (11), washers (12), and two washers (13) from hull bushing (14). Discard lockwashers.
9. Remove three cradle clips (15) and harness (16) from three cradles (17).
10. Remove two screws (18), two clamps (19), and harness (16) from weldnut (20).

CLEAN, INSPECT, AND REPAIR

11. Check leads for continuity. Use multimeter.
12. Check harness for damage. Repair damaged terminals (page 14-3).
13. Check for damaged connectors, if connectors are damaged, turn into direct support maintenance.

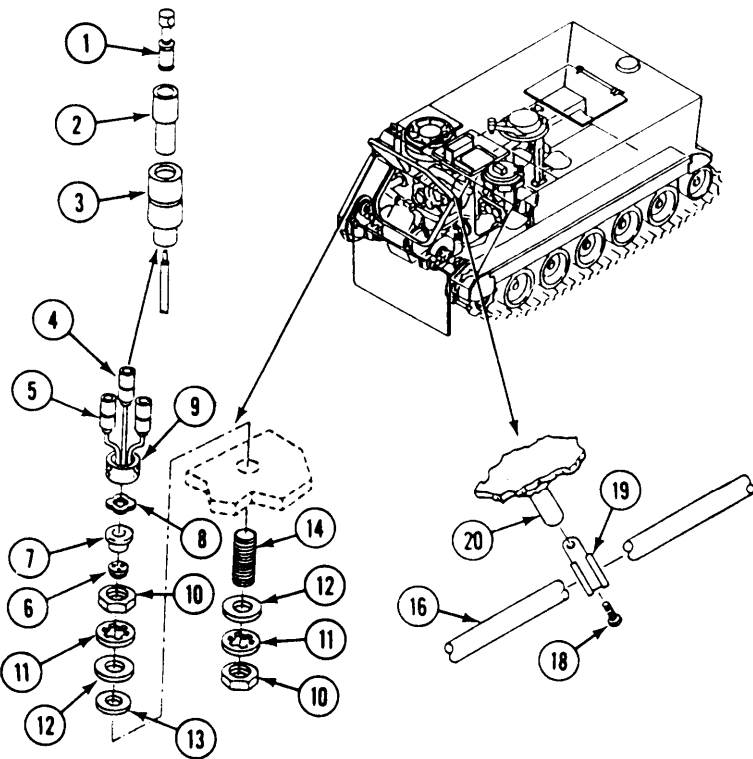

INSTALL

NOTE

New harness assembly comes with hull bushing assemblies installed.

14. Connect right headlight wiring harness (16) to front main wiring harness (21) at driver's compartment bulkhead.
15. Install clamp (19) on harness (16). Secure clamp to hull weldnut (20) with screw (18).
16. Install harness (16) on three cradles (17). Secure with three cradle clips (15).

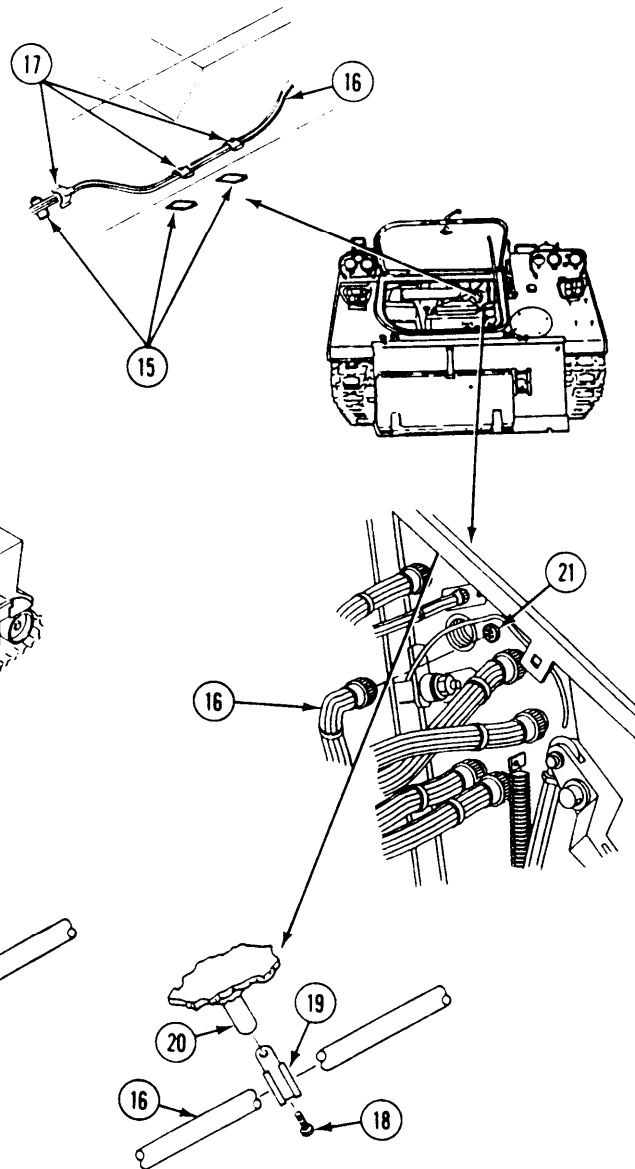

17. Thread two bushings (1) into hull. Secure with four nuts (2), new lockwashers (3), washers (4), and two washers (5). Do not tighten nuts.
18. Install spring washer (6), retainer (7), and bushing (8) into coupling (9).
19. Locate service headlight and blackout marker light bushing hole in hull. Slowly slide connector leads 17, 18, 20 (10) through hole. Do not damage wiring leads.
20. Locate second bushing hole in hull. Slowly slide connector leads 25, 514, 515 (10) through hole. Do not damage wiring leads.
21. Crimp six new terminals (11), insulators (12), and connectors (13) on six leads.
22. connect leads 514 (14) and 515 (15) to infrared headlights (16).
23. connect lead 25 (17) to horn (18).
24. Connect lead 20 (19) to blackout marker light (20).
25. Bend and tape leads 17 and 18 (21 and 22) as shown. Connect leads to service headlights (23).

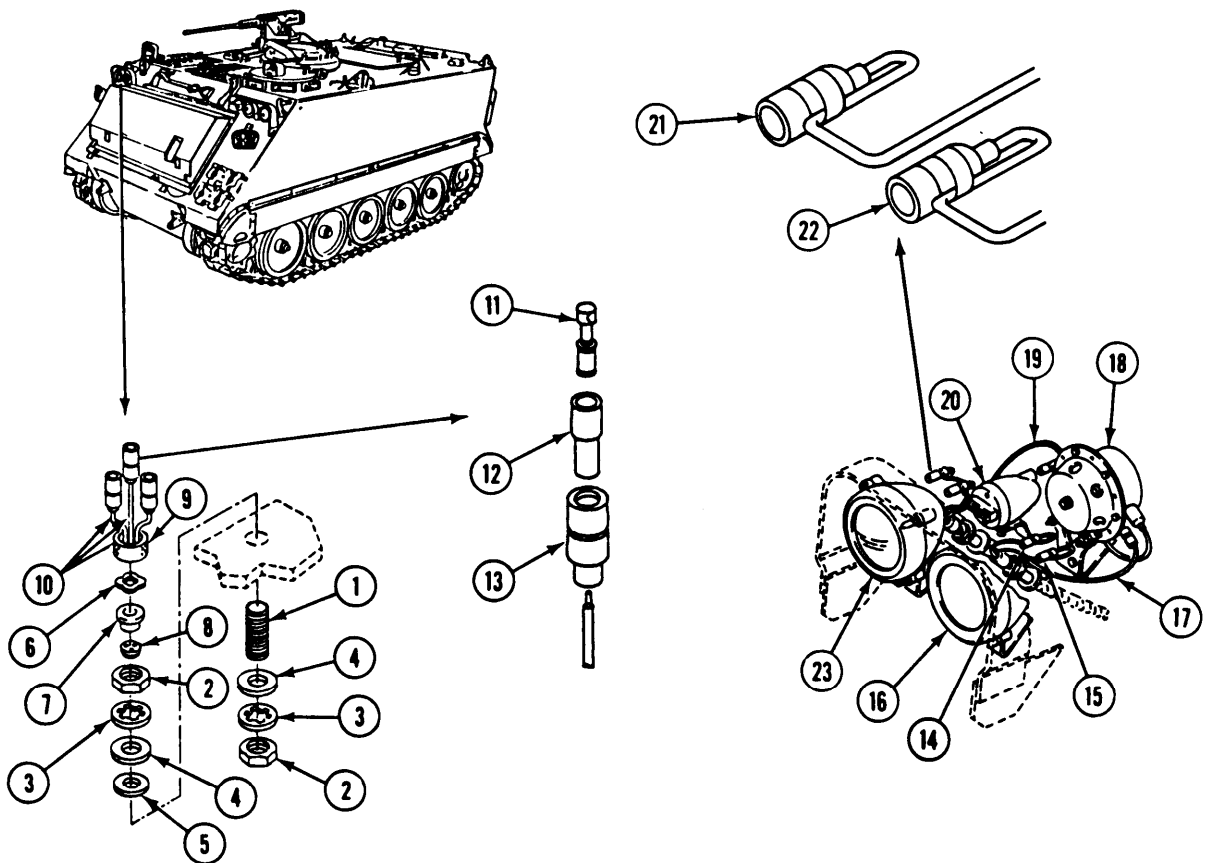

FOLLOW-THROUGH STEPS

1. Lower power plant grill (page 5-2).
2. Connect battery ground lead (page 13-2).
3. Close power plant front access door (see your -10).
4. Raise trim vane (see your -10).

END OF TASK

REPLACE REAR MAIN WIRING HARNESS (M577A2 AND M1068 ONLY)

DESCRIPTION

This task covers: Remove (page 12-82). Install (page 12-94).

INITIAL SETUP

Tools:

General Mechanics Tool Kit (Item 30, App D)

Materials/Parts:

Gasket
Grommet (12)
Lockwasher, as needed
None-electrical wire (Item 31, App D),
as needed
Self-locking nut (8)

Personnel Required:

Unit Mechanic

References:

see your -lo
TM 11-7010-256-12&P

Equipment Conditions:

Engine stopped/shutdown (see your -10)
Carrier blocked (see your -10)
Ramp lowered (see your -10)
FAX removed (see TM 11-7010-256-12&P)
Access to batteries (See Check Carrier
Batteries in your -10))
Battery ground leads disconnected (page 13-2)
Rear floor plate removed (page 24-37)

REMOVE

1. Disconnect circuit 29 lead (1) from right fuel quantity sending unit (2).
2. Remove lockwire (3), screw (4), lockwasher (5), and ground lead (6) from sending unit (2). Discard lockwire and lockwasher.
3. Remove three screws (7), two lockwashers (8), flat washer (9), ground lead (6), three clamps (10), and circuit 29 lead (1) from three weldnuts (11). Discard lockwashers.
4. Disconnect circuits 23 and 24 leads (12 and 13) from right tail light (14).
5. If NBC unit is installed, disconnect circuit 415 lead (15) from NBC unit switch.
6. Disconnect circuit 37A lead (16) from right utility outlet lead (17).

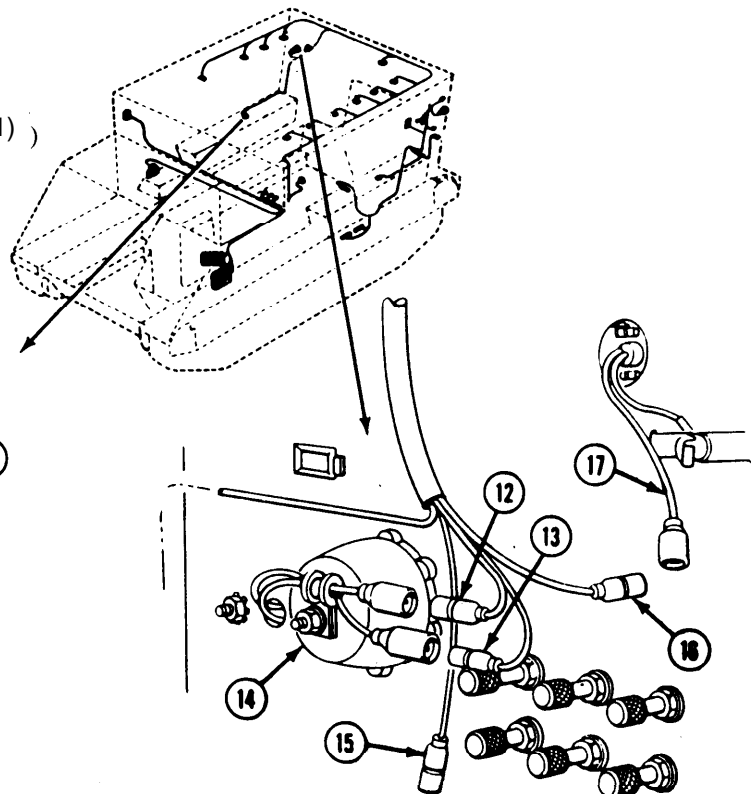
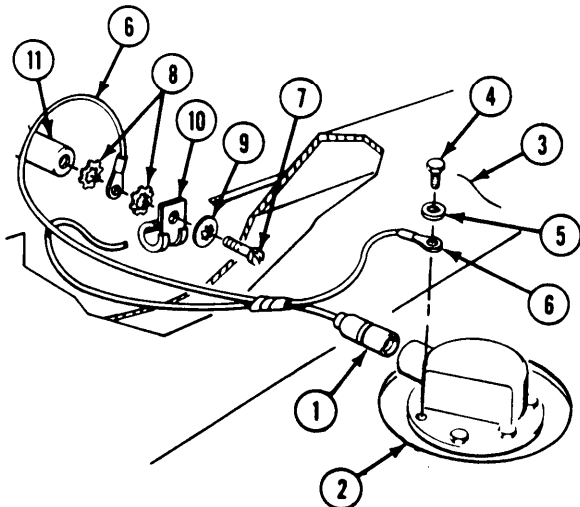

7. Remove eight cradle clips (1) and rear main wiring harness (2) from eight cradles (3).
8. Disconnect four circuit 38 leads (4) from four right side dome lights (5).
9. Remove 16 cradle clips (6) and rear main wiring harness (7) from 16 cradles (8).
10. Disconnect circuit 38B lead (9) from rear blackout dome light (10).
11. Remove two screws (11), one lockwasher (12), two clamps (13), circuit 38B lead (9), and ground lead (14) from two weldnuts (15).
12. Disconnect four circuit 38C leads (16) from four left side dome lights (17).
13. Remove screw (18), two lockwashers (19), and ground leads (20) from weldnut (21). Discard lockwasher.
14. Remove eight screws (22), nuts (23), and two circuit 48 connectors (24) from bracket (25).

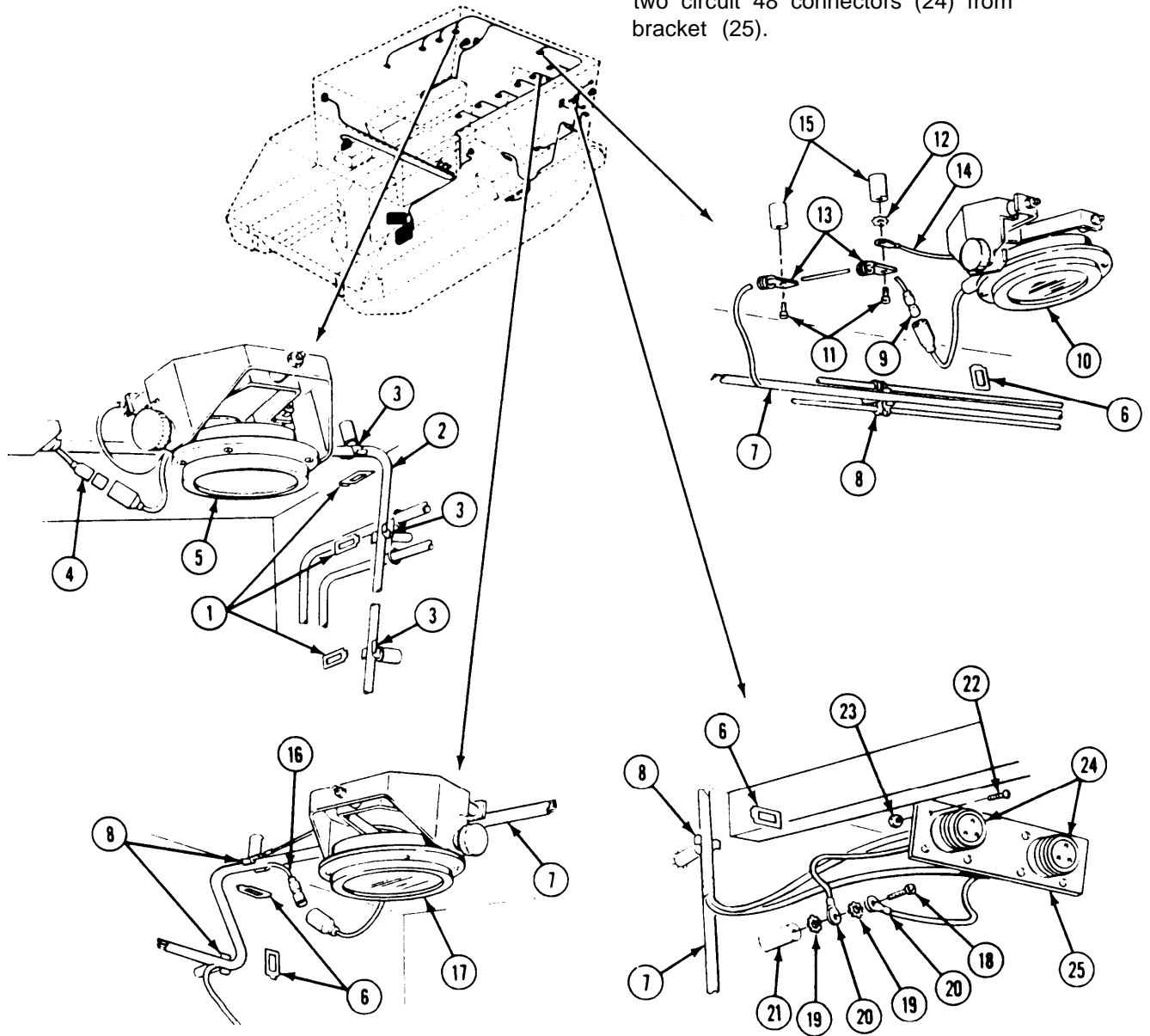

GO TO NEXT PAGE

15. Disconnect circuit 37B lead (1) from left utility outlet lead (2).
16. Disconnect circuits 21, 22, and 24 leads (3, 4, and 5) from left tail light leads (6).
17. Disconnect circuits 38, 38A, and 38E leads (7, 8, and 9) from dome light switch (10).
18. Disconnect circuits 38C and 38E leads (11 and 12) from blackout dome light switch (13).
19. Disconnect circuit 509 and 509A connector (14) from buzzer switch (15).
20. Remove seven cradle clips (16) and main rear wiring harness (17) from seven cradles (18).
21. Remove two screws (19), one lockwasher (20), two clamps (21), and circuits 30 and 509 leads (22 and 23) from two weldnuts (24). Discard lockwasher.
22. Disconnect circuit 509 lead (23) from buzzer (25).

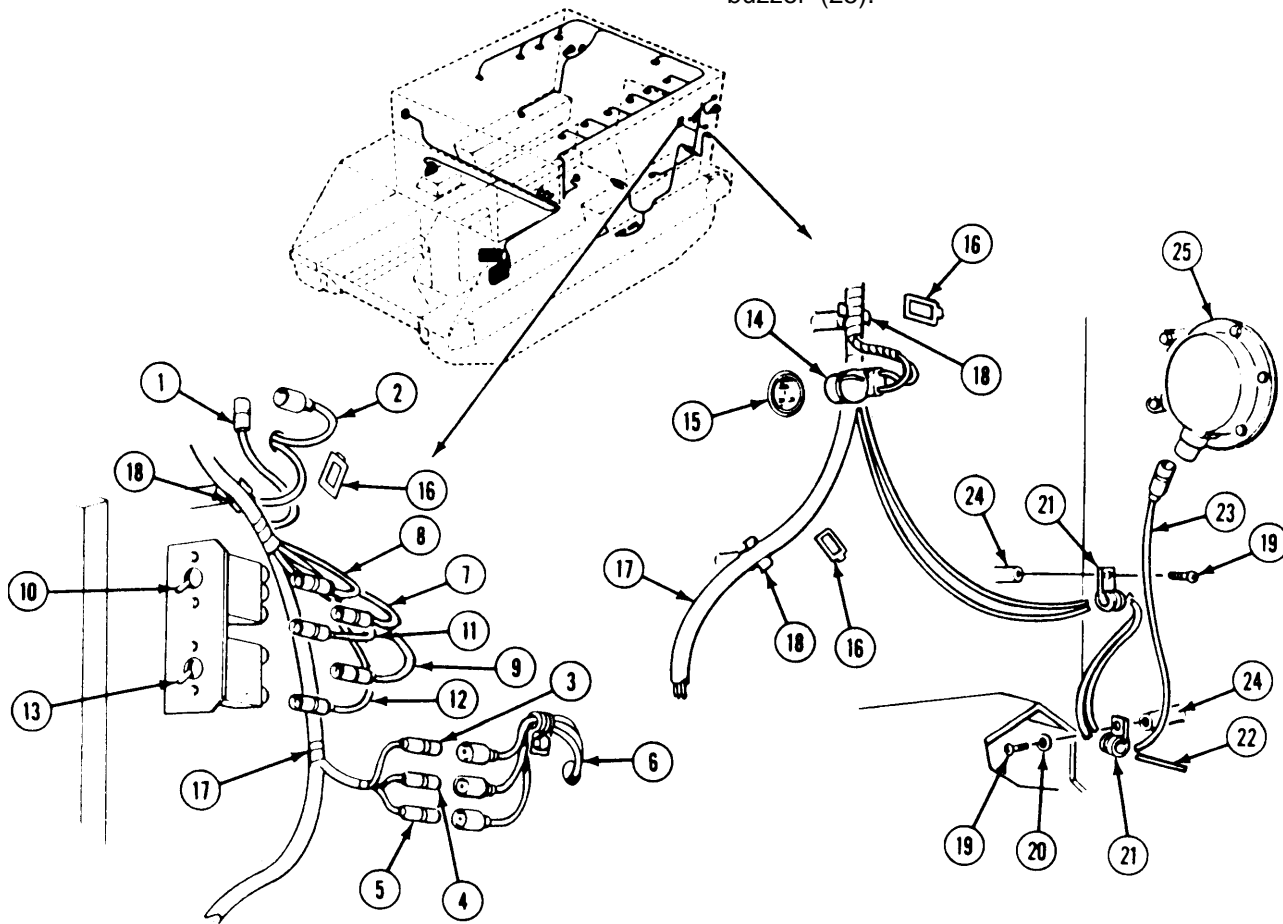

23. Disconnect circuit 30 lead (1) from left fuel quantity sending unit (2).
24. Remove lockwire (3), one screw (4), lockwasher (5), and ground lead (6) from sending unit (Z). Discard lockwire and lockwasher.
25. Remove two screws (7), clamps (8), lockwashers (9), circuit 30 lead (1), and ground lead (6) from two weldnuts (10). Discard lockwashers.
26. Disconnect circuit 402 lead (11) from personnel heater fuel pump (12).
27. Remove screw (13), lockwasher (14), clamp (15), and rear main wiring harness (16) from weldnut (17). Discard lockwasher.
28. Remove two screws (18), nuts (19), clamp (20), and rear main wiring harness (16) from floor transverse beam (21).
29. Remove screw (22), nut (23), and clamp (20) from wiring harness (16).
30. Remove three cradle clips (24) and rear main wiring harness (16) from cradles (25).

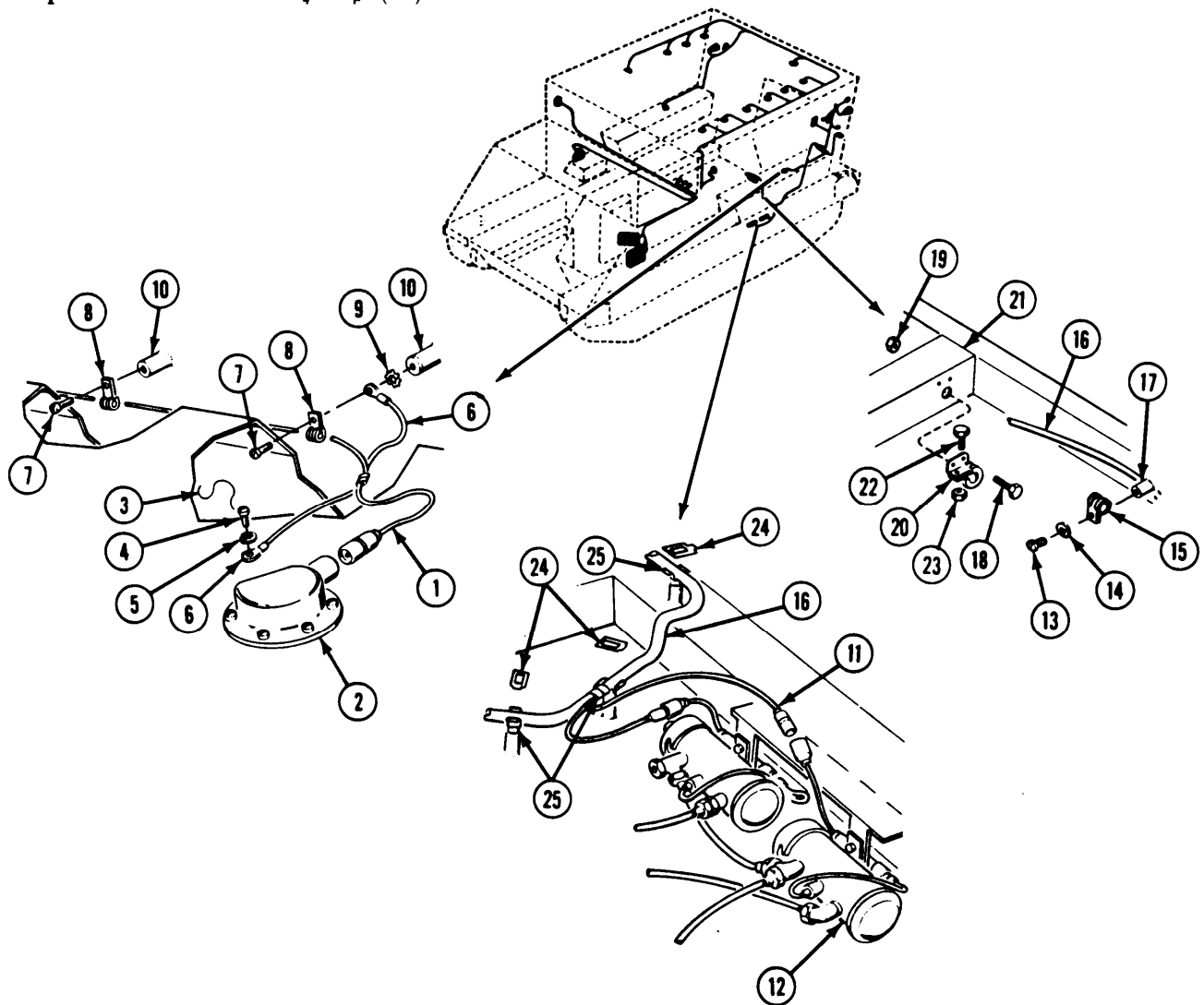

GO TO NEXT PAGE

31. Disconnect circuits 21, 22, 23, and 24 leads (1, 2, 3, and 4) from trailer wiring harness (6).
32. Disconnect circuit 451 lead (6) from rear bilge pump (7).
33. Remove screw (8), clamp (9), two lockwashers (10), trailer wiring harness ground lead (11), and wiring harness (12) from weldnut (13). Discard lockwashers.
34. Pull circuits 21, 22, 23, 24, and 451 leads (1, 2, 3, 4, and 6) through opening in transverse beam.
35. Remove two screws (14), clamps (15), and wiring harness (12) from two weldnuts (16).
36. Remove eight cradle clips (17) and wiring harness (12) from eight cradles (18).
37. Disconnect circuit 38C lead (19) from left dome light (20).
38. Disconnect circuit 38B lead (21) from front blackout light (22) and cables W28 and W35.

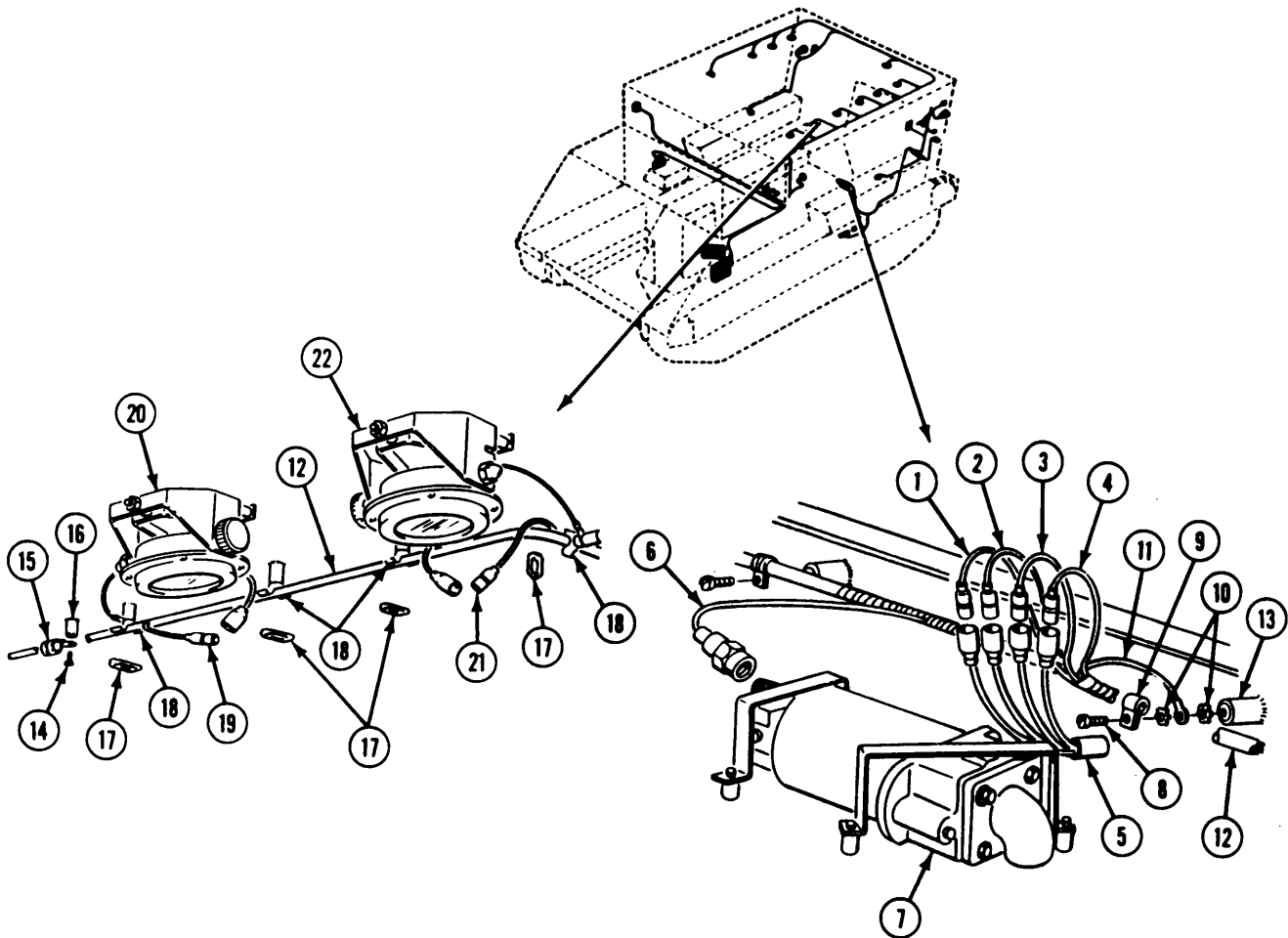

39. Remove four screws (1), nuts (2), and circuit 48A lead (3) from bracket (4).
40. Remove two screws (5), lockwashers (6), clamps (7), and circuit 48A lead (3) from two weldnuts (8). Discard lockwashers.
41. Remove screw (9), three lockwashers (10), and ground leads (11) from weldnut (12). Discard lockwashers.
42. Remove cradle clip (13) and rear main wiring harness (14) from cradle (15).
43. Remove screw (16), cradle (15), circuit 48C capacitor (17), and lockwasher (18) from weldnut (19). Discard lockwashers.
44. Remove 12 screws (20), nuts (21), and 3 circuit 48 leads (22) from bracket (23).

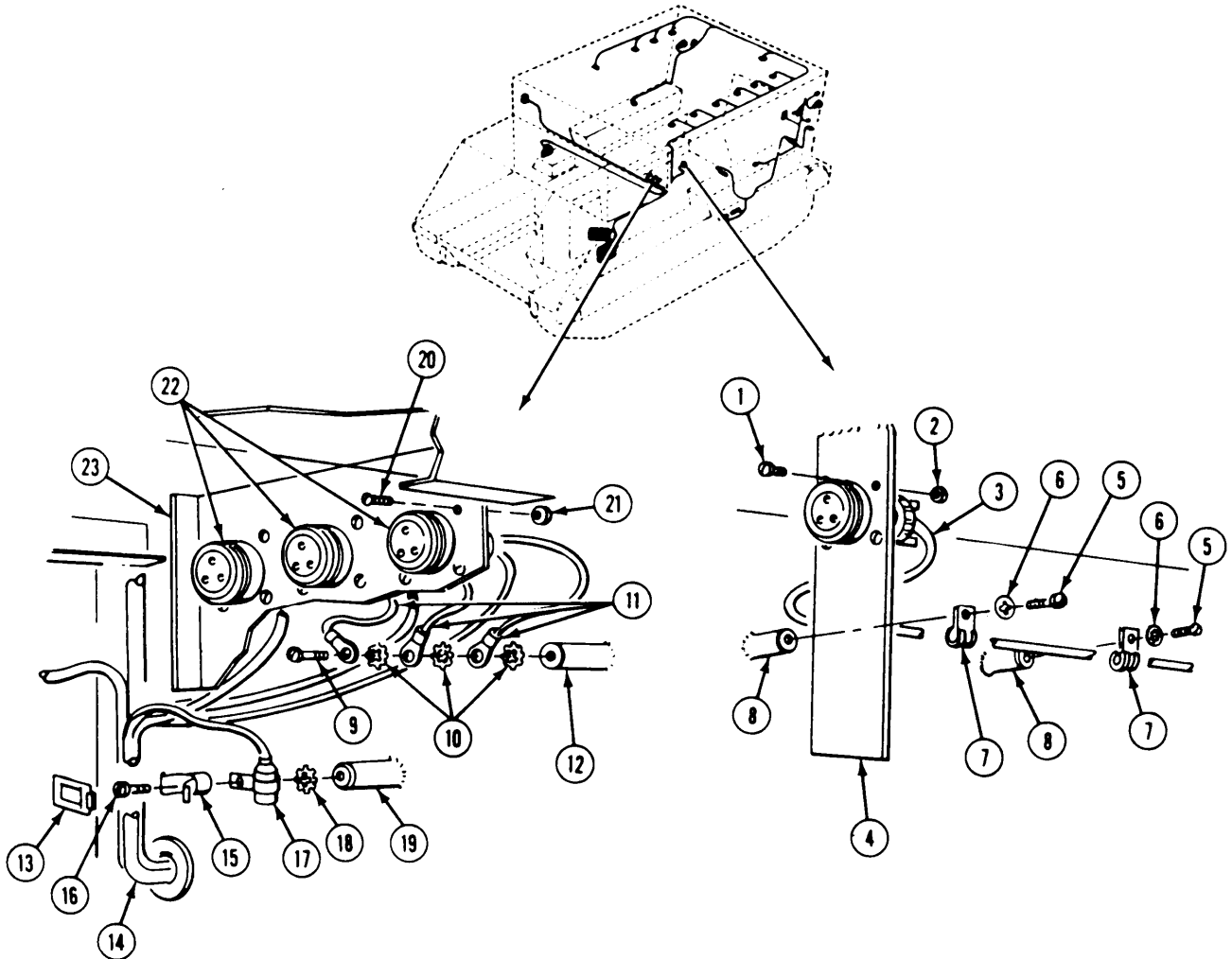

GO TO NEXT PAGE

45. Disconnect circuit 59 lead (1) from blower (2).
46. Remove screw (3), lockwasher (4), clamp (5), and circuits 59 and 415 leads (1 and 6) from weldnut (7). Discard lockwasher.
47. If NBC unit is installed, disconnect circuit 415 lead (6) from NBC unit.
48. Remove four screws (8), nuts (9), and circuit 48 (10) from bracket (11).
49. Remove screw (12), two lockwashers (13), circuit 48 capacitor (14), and ground lead (15) from weldnut (16). Discard lockwashers.
50. Remove six screws (17), clamps (18), and circuit 48 lead (10) from six weldnuts (19).

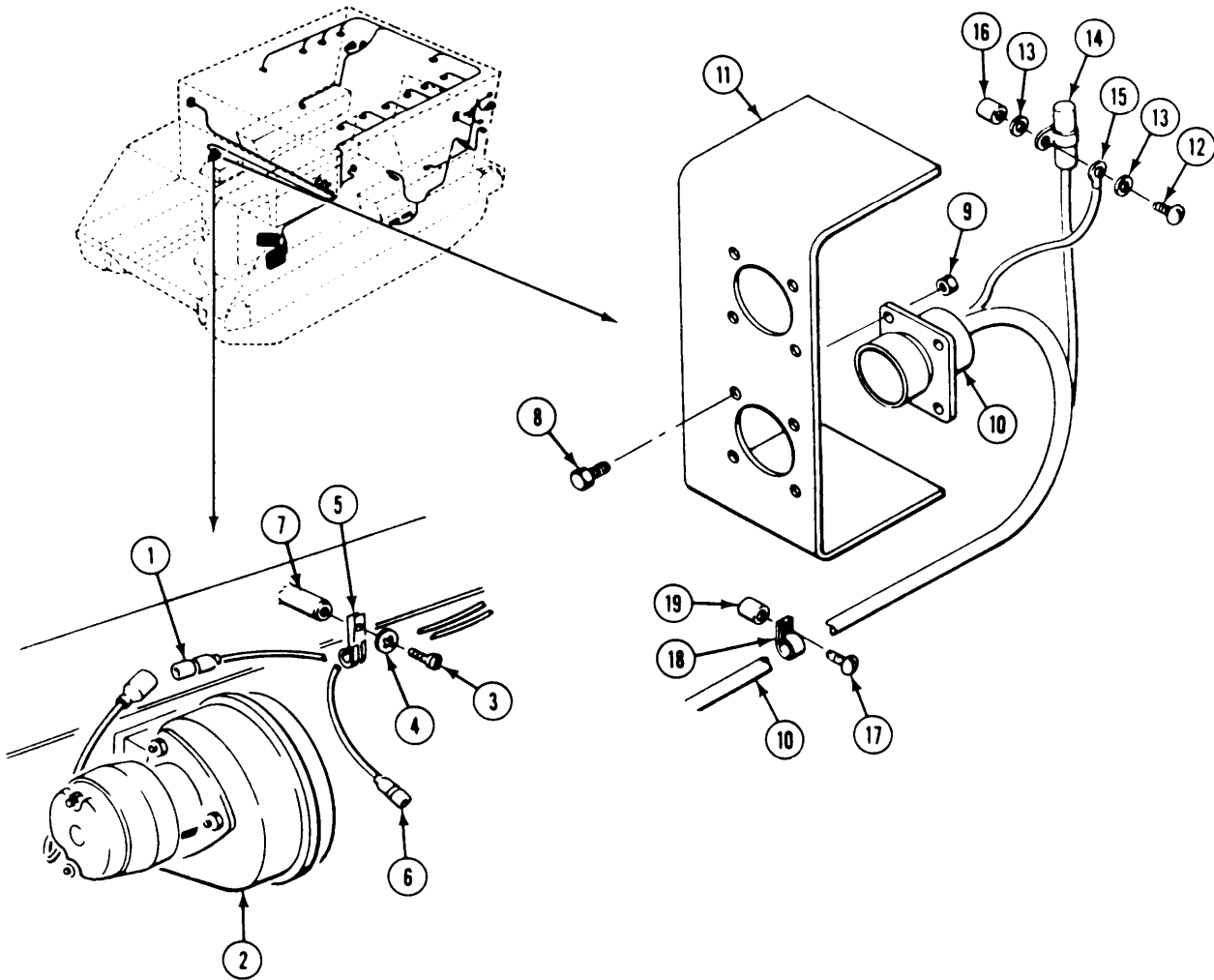

51. Disconnect circuit 400 lead (1) from personnel heater control box.
52. Disconnect circuit 402 lead (2) from personnel heater wiring harness.
53. If NBC unit is installed, disconnect circuit 415 lead (3) from NBC unit.
54. Remove eight locknuts (4), washers (5), and screws (6). Separate master switch panel (7) from distribution box (8). Discard locknuts.
55. Disconnect wiring harness (9) from circuit 10 on three circuit breakers (10, 11, and 12) in master switch panel (7).
56. Disconnect wiring harness (13) from circuit 38E lead (14).

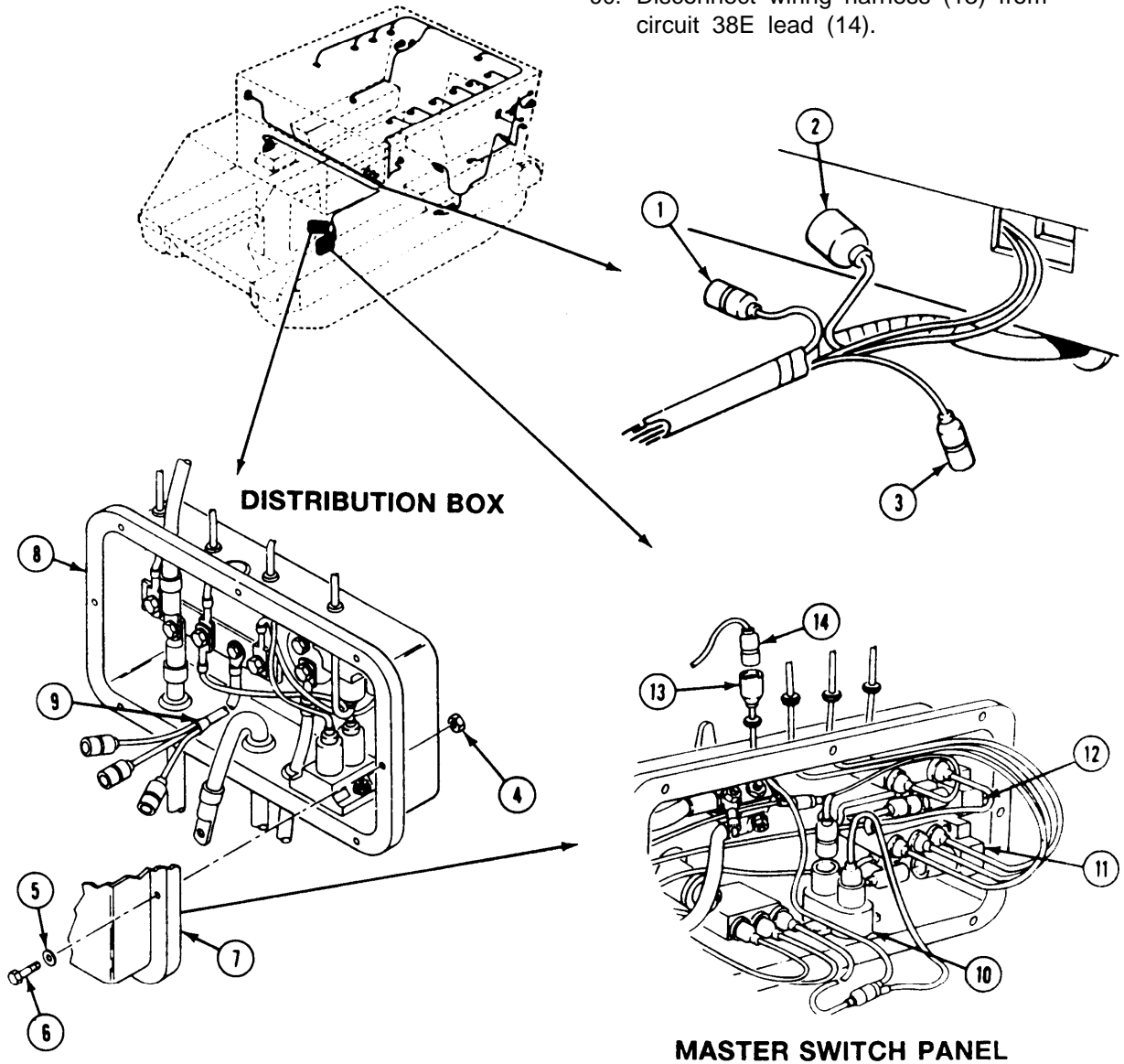

GO TO NEXT PAGE

- 57. Disconnect circuit 59 lead (1) from blower switch (2).
- 58. Disconnect circuit 37B lead (3) from blower switch (2) and circuit breaker (4).
- 59. Remove circuits 59 and 37B leads (1 and 3) and two grommets (5) from master switch panel (6). Discard grommets.
- 60. Disconnect circuit 37A lead (7) from circuit breaker (8).
- 61. Disconnect circuits 38 and 38A leads (9 and 10) from dome light switch (11).
- 62. Remove circuits 37A, 38, and 38A leads (7, 9, and 10) and three grommets (12) from master switch panel (6). Discard grommets.

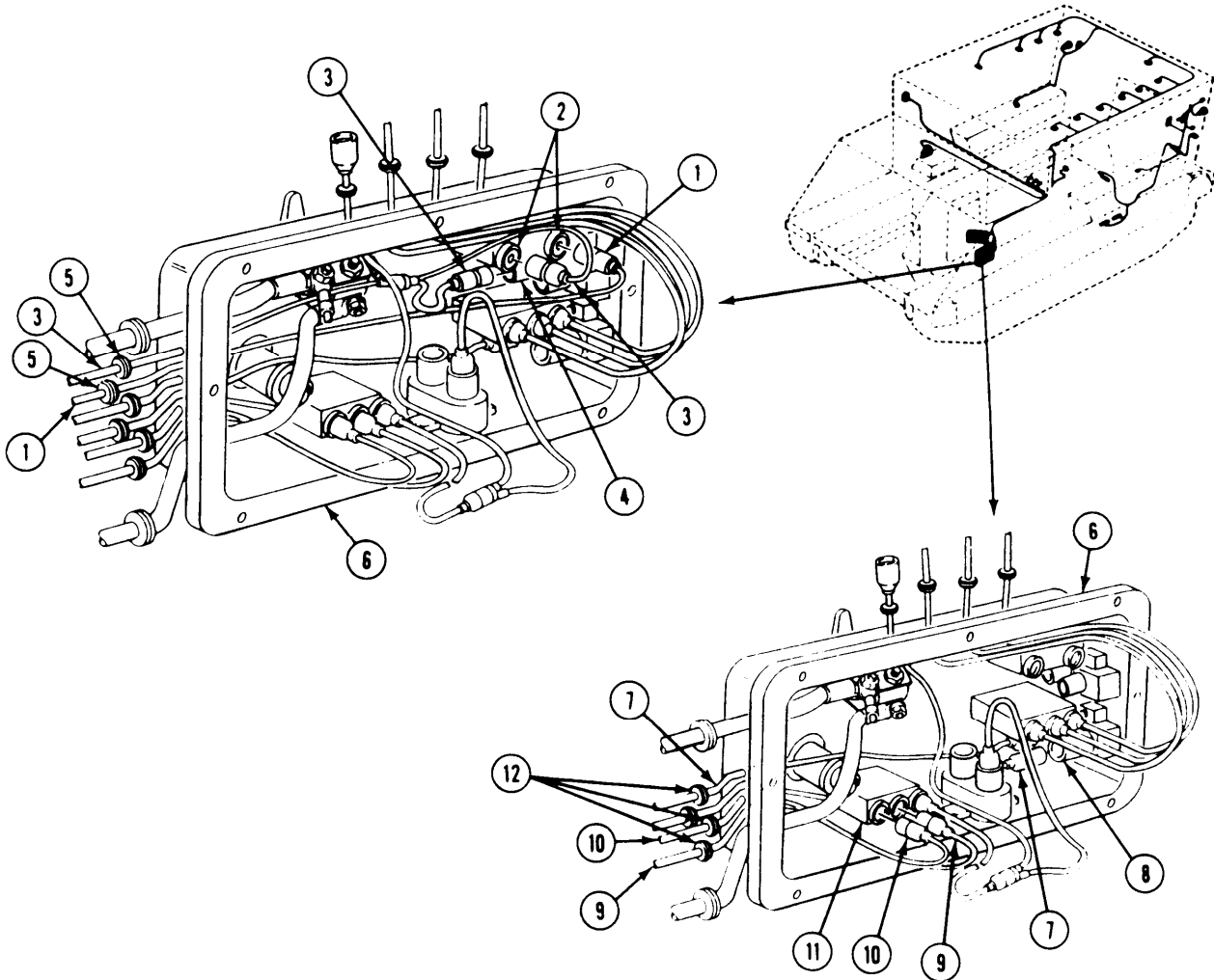

- 63. Disconnect circuits 28, 29, and 30 leads (1, 2, and 3) from fuel selector switch (4).
- 64. Remove circuits 28, 29, and 30 leads (1, 2, and 3) and three grommets (5) from master switch panel (6). Discard grommets.
- 65. Disconnect circuit 450 lead (7) from circuit breaker (8).

- 66. Disconnect circuit 450B lead (9) from circuit breaker (10).
- 67. Remove circuit 450 lead (7) and grommet (11) from distribution box (12). Discard grommet.
- 68. Remove circuit 450B lead (9) and grommet (13) from distribution box (12). Discard grommet.

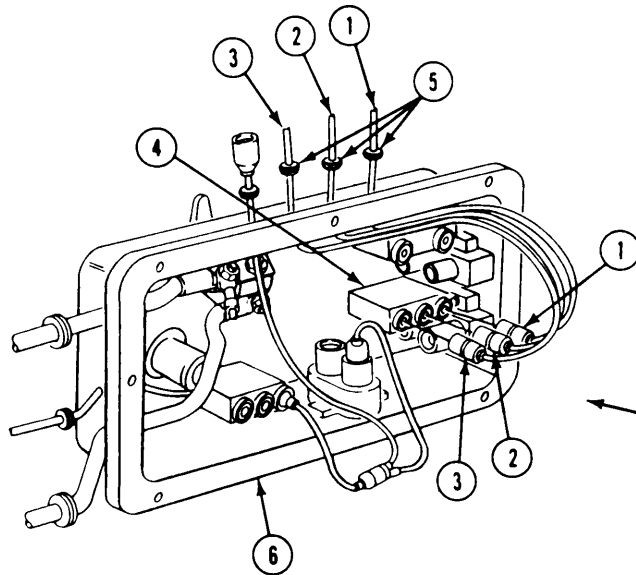

MASTER SWITCH PANEL

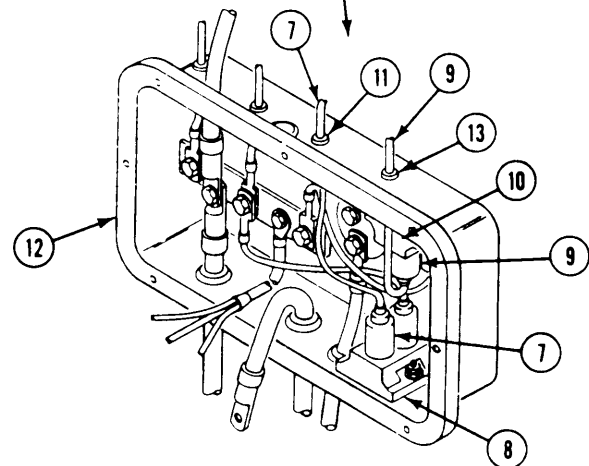
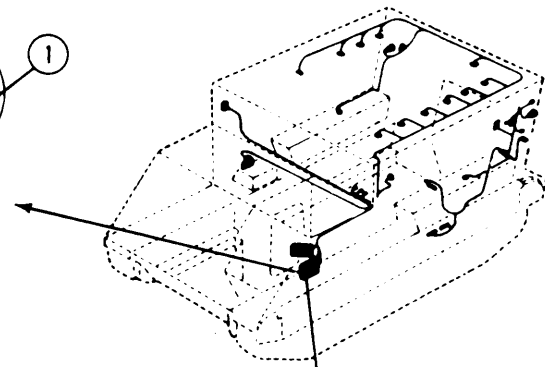

DISTRIBUTION BOX

GO TO NEXT PAGE

69. Remove two nuts (1), mounts (2 and 3), flat washers (4), and screws (5) that secure instrument panel (6) to two struts (7).
70. Support panel (6). Remove two screws (8), flat washers (9), one lockwasher (10), and ground lead (11), from two mounts (12) and upper support (13). Discard lockwasher.
71. Support panel (6) on two struts (7) to gain access to rear of panel.
72. Disconnect circuit 28 lead (14) from fuel gage.
73. Disconnect circuit 451B lead (15) from rear bilge pump ON indicator light.
74. Disconnect circuit 38 lead (16) from instrument panel wiring harness,
75. Disconnect circuits 450, 450B, and 451A (17, 18, and 19) from bilge pump switch.
76. Disconnect circuits 21, 22, 23, and 24 leads (20, 21, 22, and 23) from front main wiring harness.

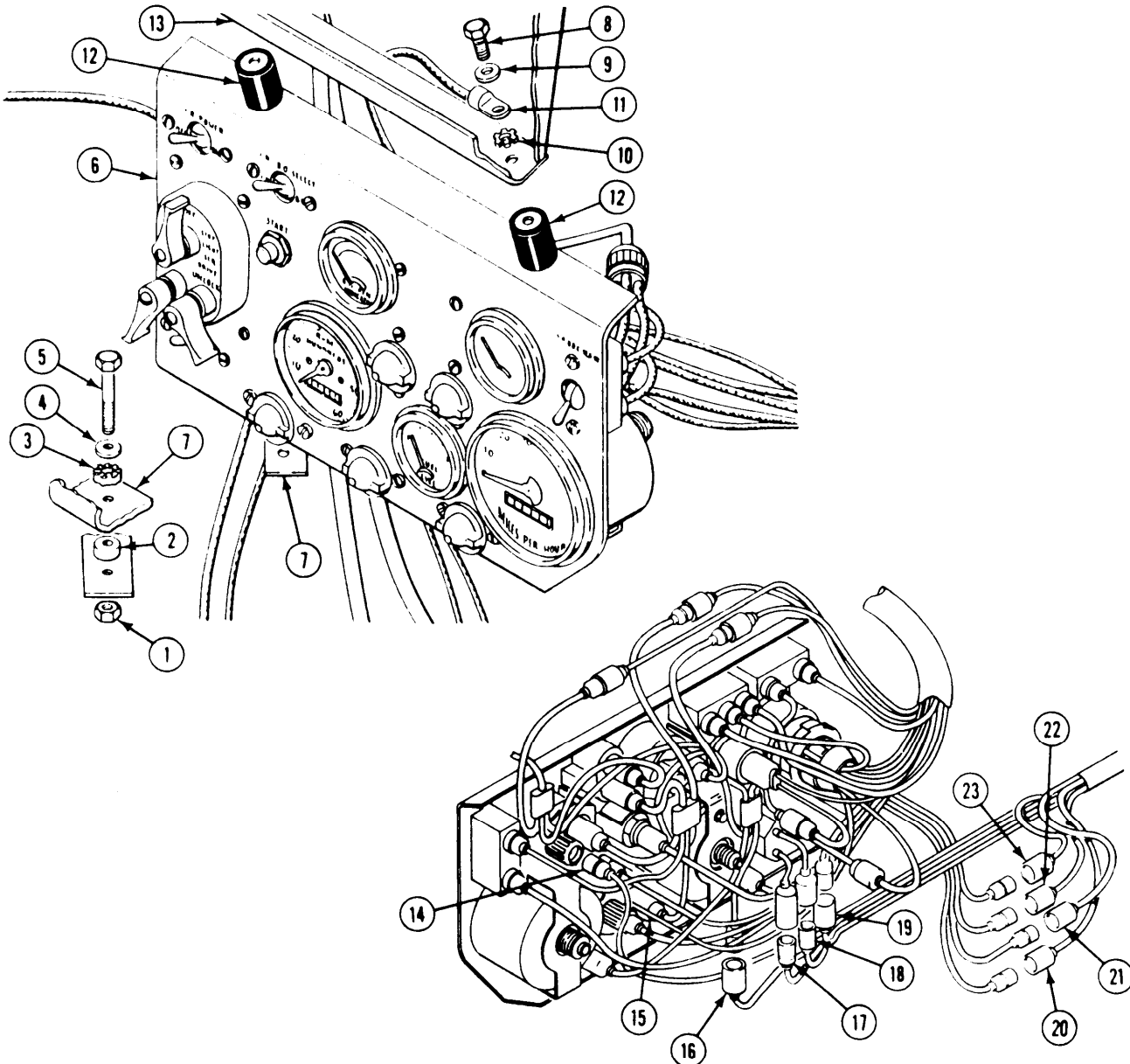

NOTE

Do steps 77 and 78 for M677A2 only

- 77. Remove screw (1), nut (2), and circuits 6 and 48B leads (3 and 4) from terminal (5).
- 78. Remove circuits 48B and 6 leads (4 and 3) and two grommets (6) from battery box (7). Discard grommets.

- 79. Remove screw (1), nut (2), circuit 6 lead (3), circuit lead 48B (4), and circuit 31 lead (8) from terminal (5).

- 80. Remove circuit 6 lead (3), circuit 48B lead (4), circuit 31 lead (8), and two grommets (9 and 10) from battery (7). Discard grommets.

NOTE

Do steps 79 and 80 for M1068 only.

- 81. Disconnect circuits 38, 38B, and 38C leads (11, 12, and 13) from door switch (14).

- 82. Remove rear main wiring harness (15) from earner.

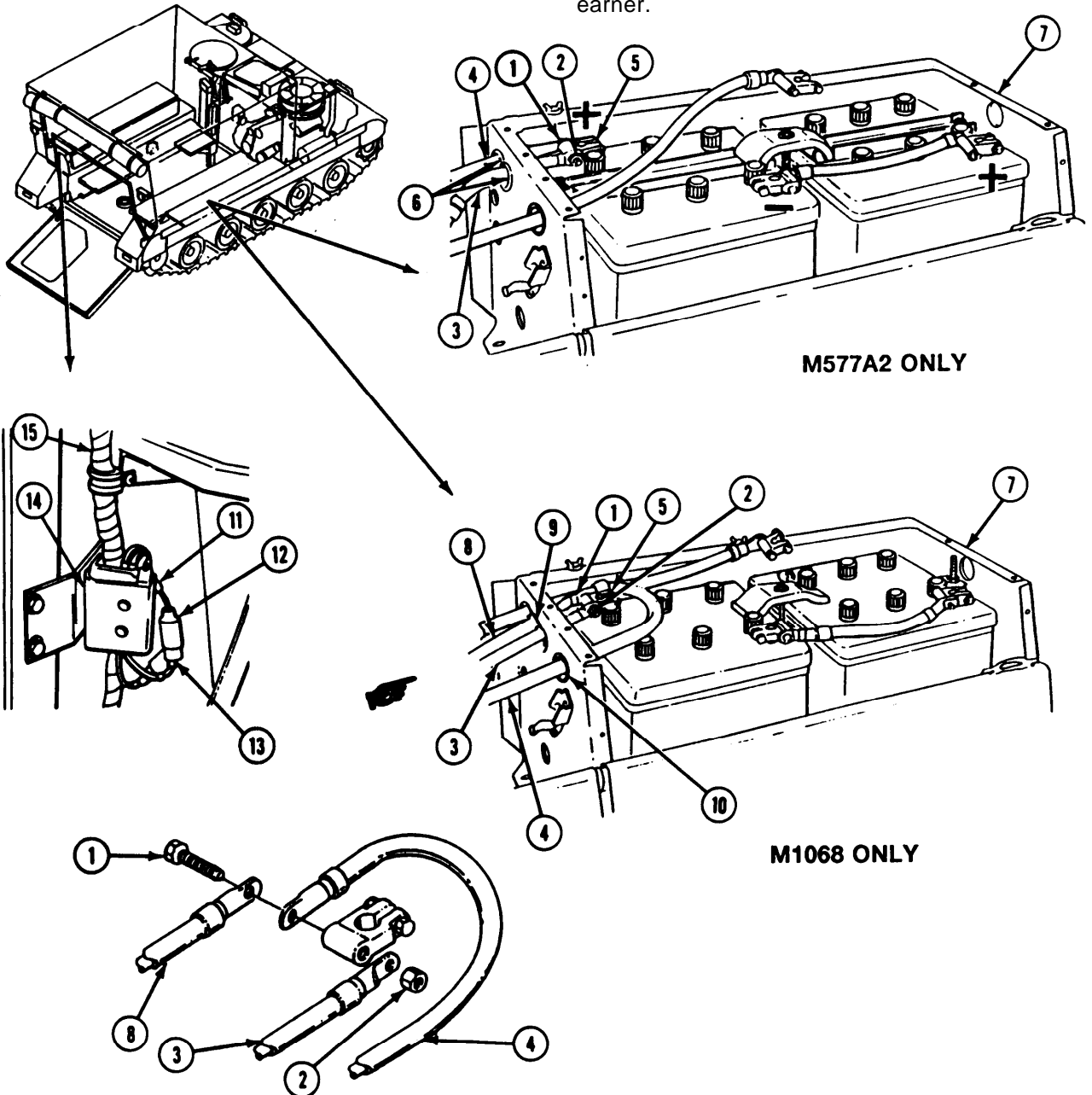

GO TO NEXT PAGE

INSTALL

- 83. Install main rear wiring harness (1) in earner.
- 84. Connect circuits 38, 38B, and 38C leads (2, 3, and 4) to ramp door switch (5).

NOTE

Do steps 85 and 86 for M577A2 only.

- 85. Install two new grommets (6) in battery box (7).
- 86. Install circuits 6 and 48B leads (8 and 9) through two new grommets (6). Connect leads to terminal (10) with screw (11) and nut (12).

NOTE

Do steps 87 thru 88.2 for M1068 only.

- 87. Install two new grommets (13 and 14) in battery box (7).
- 88. Install circuit 6 lead (8), and circuit 31 lead (15) through grommet (13).
- 88.1. Install circuit 48B lead (9) through grommet (14).
- 88.2. Connect circuit 6 lead (8), circuit 48B lead (9), and circuit 31 lead (15) to terminal (10) with screw (11) and nut (12).

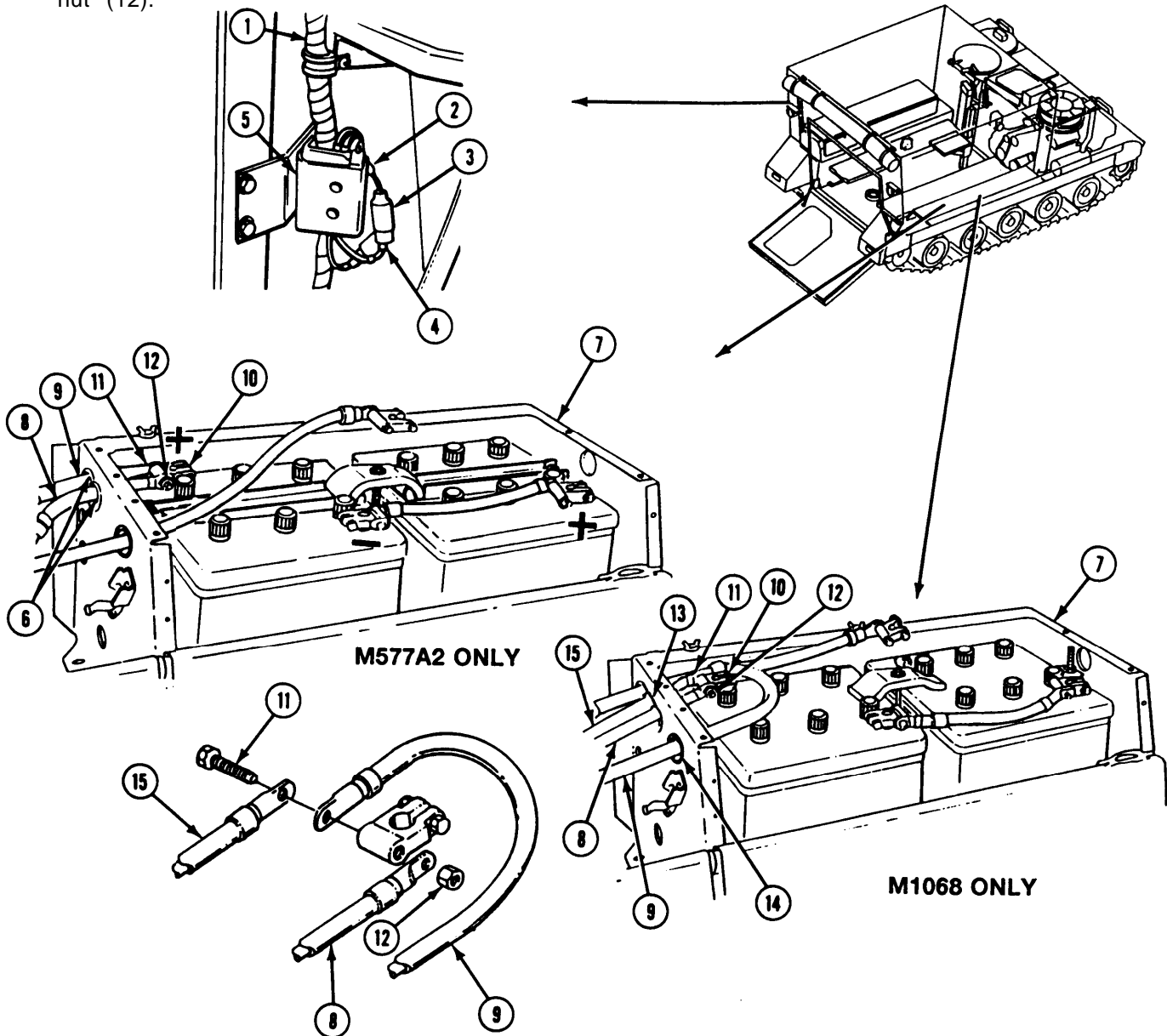

89. Connect circuits 21, 22, 23, and 24 leads (1, 2, 3, and 4) to front main wiring harness.
90. Connect circuits 450, 450B, and 451A leads 5, 6, and 7) to bilge pump switch.
91. Connect circuit 38 lead (8) to instrument panel wiring harness.
92. Connect circuit 451B lead (9) to rear bilge pump ON indicator light.
93. Connect circuit 28 lead (10) to fuel gage.
94. Support instrument panel (11) on two struts (12).
95. Install ground lead (13) and new lockwasher (14) on upper support (15). Install panel (11) with two mounts (16) on support (15). Secure with two screws (17) and flat washers (18).
96. Install panel (11) on two struts (12). Secure with two nuts (19), mounts (20 and 21), flat washers (22), and screws (23).

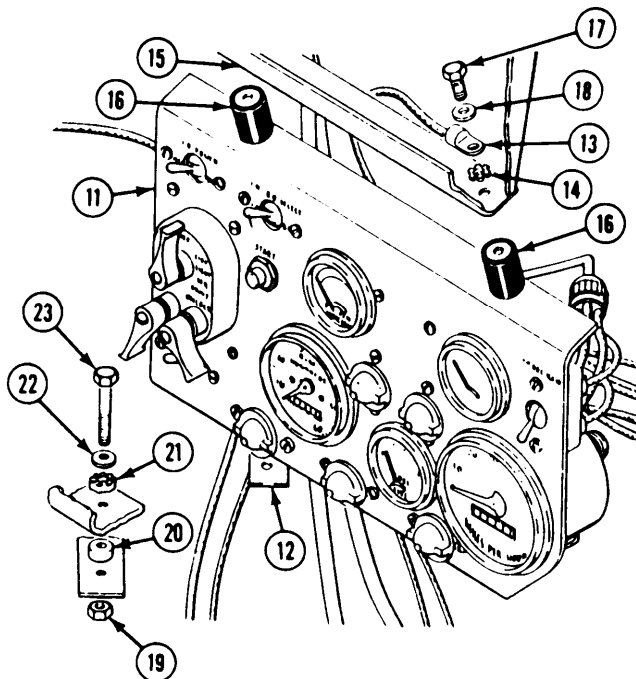
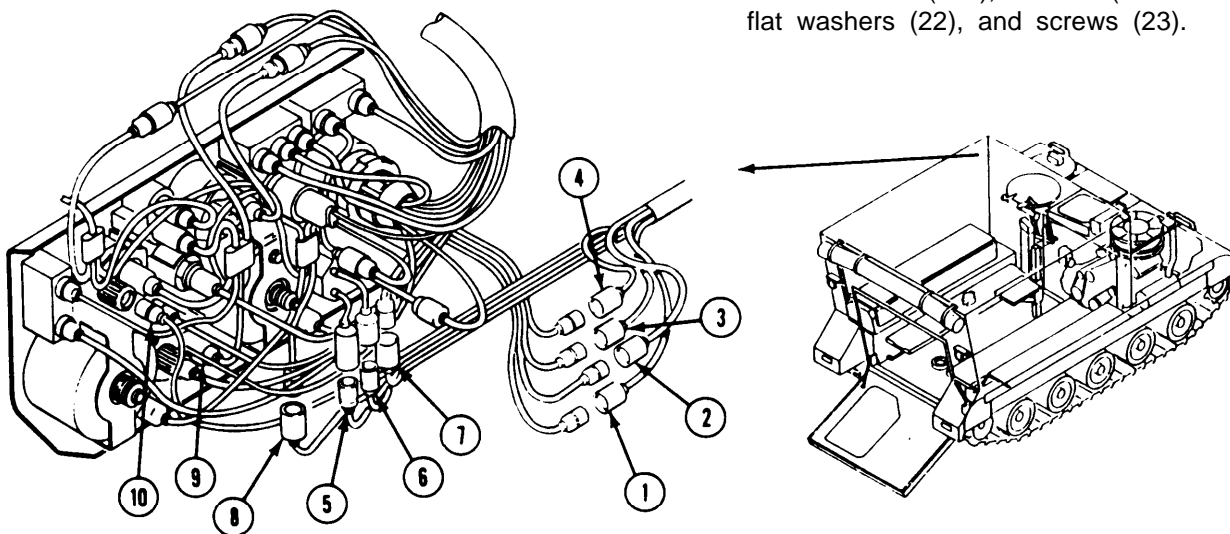

GO TO NEXT PAGE

97. Install circuit 450B lead (1) and new grommet (2) in distribution box (3).
98. Install circuit 450 lead (4) and new grommet (5) in distribution box (3).
99. Connect circuit 450B lead (1) to circuit breaker (6).
100. Connect circuit 450 lead (4) to circuit breaker (7).
101. Install circuits 28, 29, and 30 leads (8, 9 and 10) and three new grommets (11) in master switch panel (12).
102. Connect circuits 28, 29, and 30 leads (8, 9, and 10) to fuel selector switch (13).
103. Install circuits 37A, 38, and 38A leads (14, 15, and 16) and three new grommets (17) in master switch panel (12).
104. Connect circuits 38 and 38A leads (15 and 16) to dome light switch (18).
105. Connect circuit 37A lead (14) to circuit breaker (19).

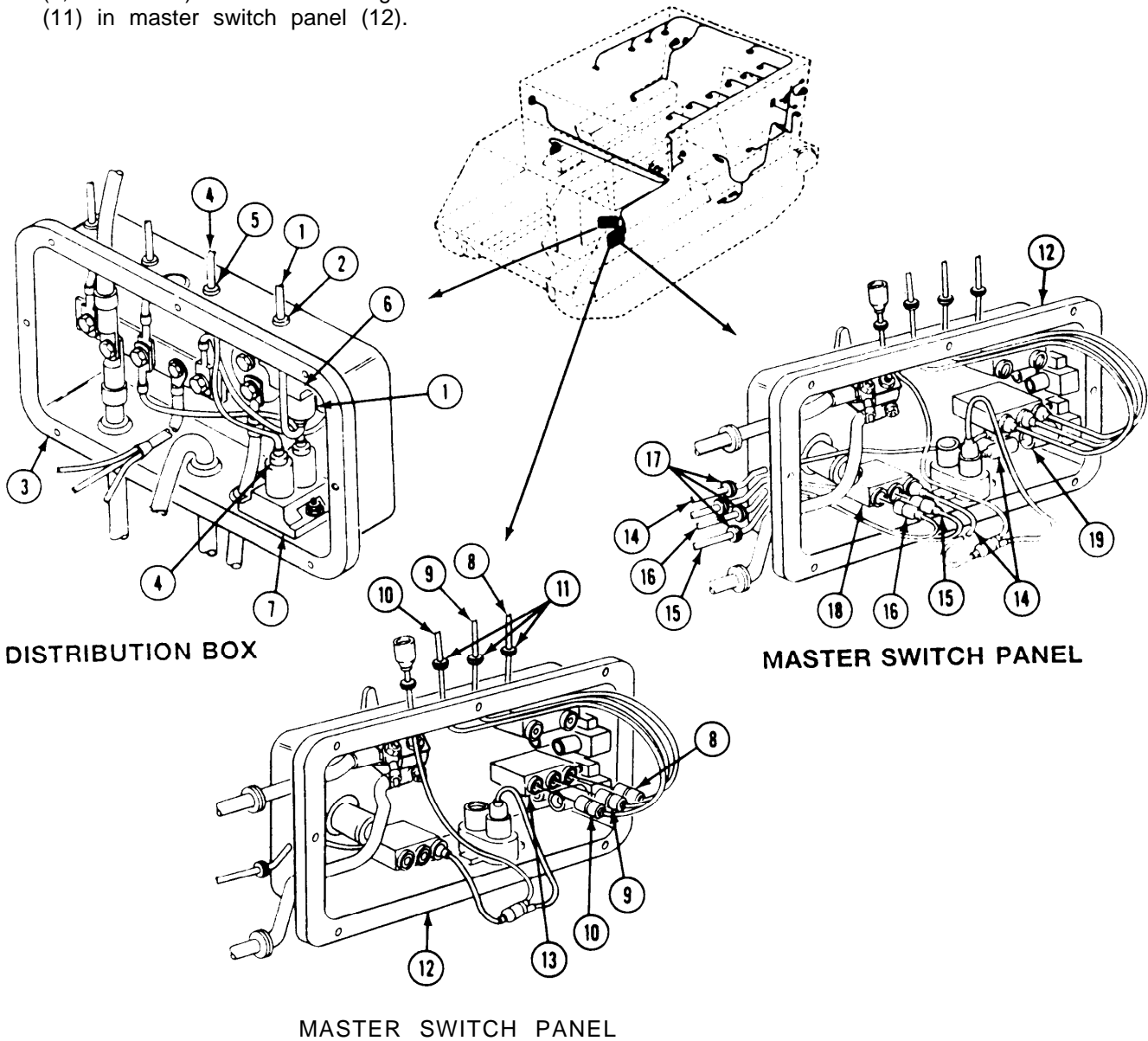

- 106. Install circuits 59 and 37B leads (1 and 2) and two grommets (3) in master switch panel (4).
- 107. Connect circuit 37B lead (2) to blower switch (5) and circuit breaker (6).
- 108. Connect circuit 59 lead (1) to blower switch (5).

- 109. Connect wiring harness (7) to circuit 38E lead (8).
- 110. Connect wiring harness (9) to circuit 10 on three circuit breakers (10, 11, and 12) in master switch panel (4).

NOTE
Inspect gasket (17). Replace if damaged.

- 111. Install master switch panel (4) on distribution box (13), Secure with eight screws (14), washers (15), and new locknuts (16).

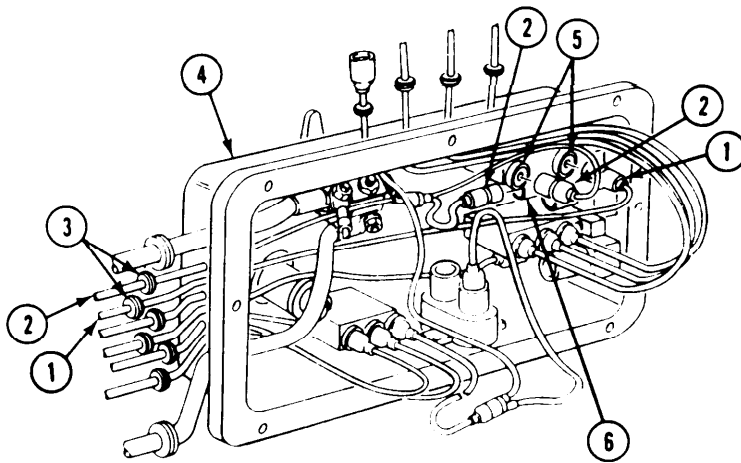

MASTER SWITCH PANEL

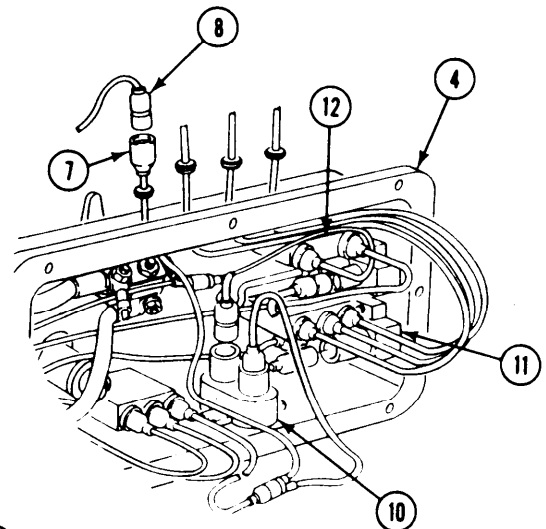

MASTER SWITCH PANEL

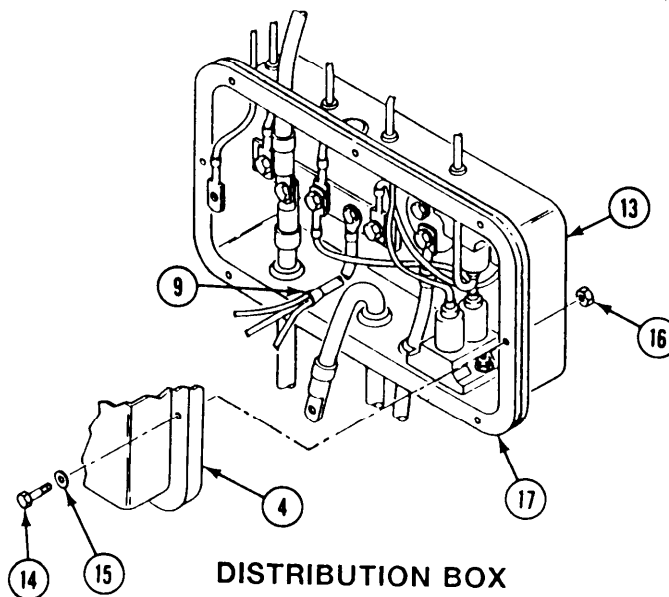

DISTRIBUTION BOX

GO TO NEXT PAGE

- 112. If NBC unit is installed, connect circuit 415 lead (1) to NBC unit.
- 113. Connect circuit 402 lead (2) to personnel heater wiring harness.
- 114. Connect circuit 400 lead (3) to personnel heater control box.

- 115. Install six clamps (4) and circuit 48 lead (5) on six weldnuts (6). Secure with six screws (7).
- 116. Install two new lockwashers (8), circuit 48 capacitor (9), and ground lead (10) on weldnut (11). Secure with screw (12).
- 117. Install circuit 48 lead (5) on bracket (13). Secure with four screws (14) and nuts (15).

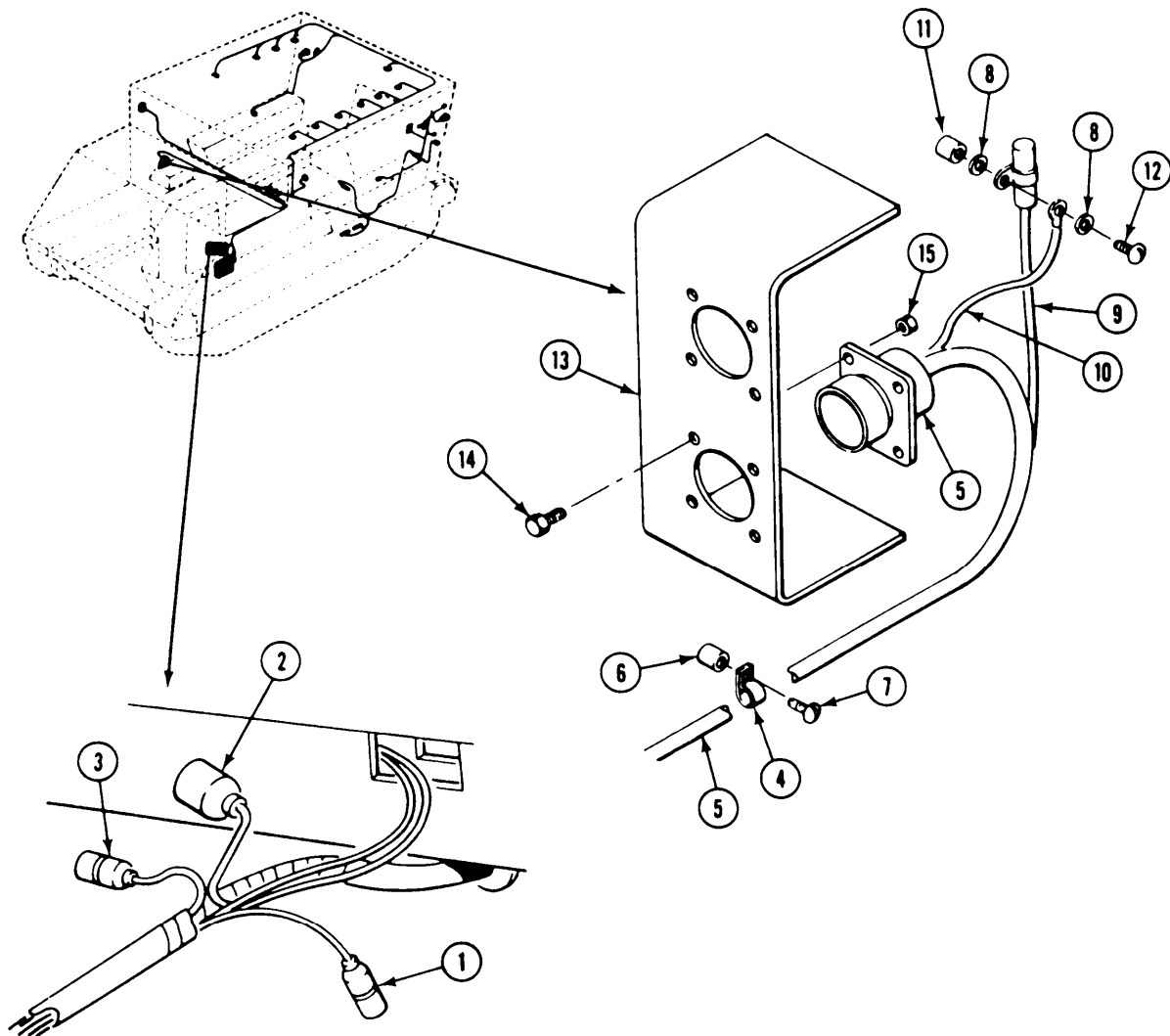

118. If NBC unit is installed, connect circuit 415 lead (1) to NBC unit.

119. Install circuits 69 and 415 leads (2 and 1), clamp (3), and new lockwasher (4) On weldnut (5). Secure with screw (6).

120. Connect circuit 59 lead (2) to blower (7).

121. Install three circuit 48 leads (8) on bracket (9). Secure with 12 screws (10) and nuts (11).

122. Install cradle (12), circuit 48C capacitor (13), and new lockwasher (14) on weldnut (15). Secure with Screw (16).

123. Install rear main wiring harness (17) on cradle (12). Secure with cradle clip (18).

124. Install three ground leads (19) and new lockwashers (20) on weldnut (21). Secure with screw (22) .

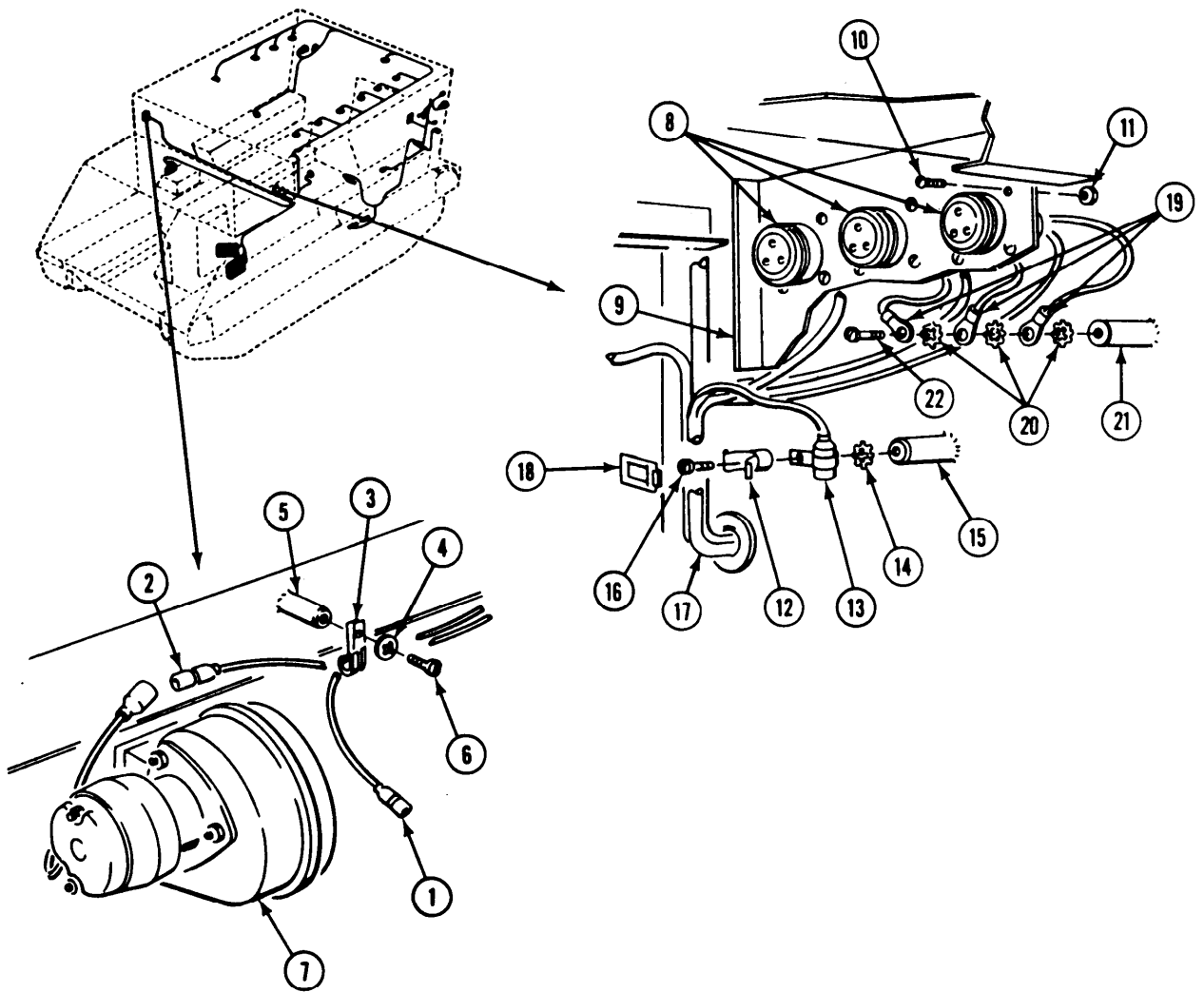

GO TO NEXT PAGE

- 125. Install circuit 48A lead (1), two clamps (2), and new lockwashers (3) on two weldnuts (4). Secure with two screws (5).
- 126. Install circuit 48A lead (1) on bracket (6). Secure with four screws (7) and nuts (8).
- 127. Connect circuit 38B lead (9) to front blackout light (10) and cables W28 and W25.
- 128. Connect circuit 38C lead (11) to left dome light (12).
- 129. Install wiring harness (13) on eight cradles (14). Secure with eight cradle clips (15).
- 130. Install two clamps (16) and wiring harness (13) on two weldnuts (17). secure with two screws (18).

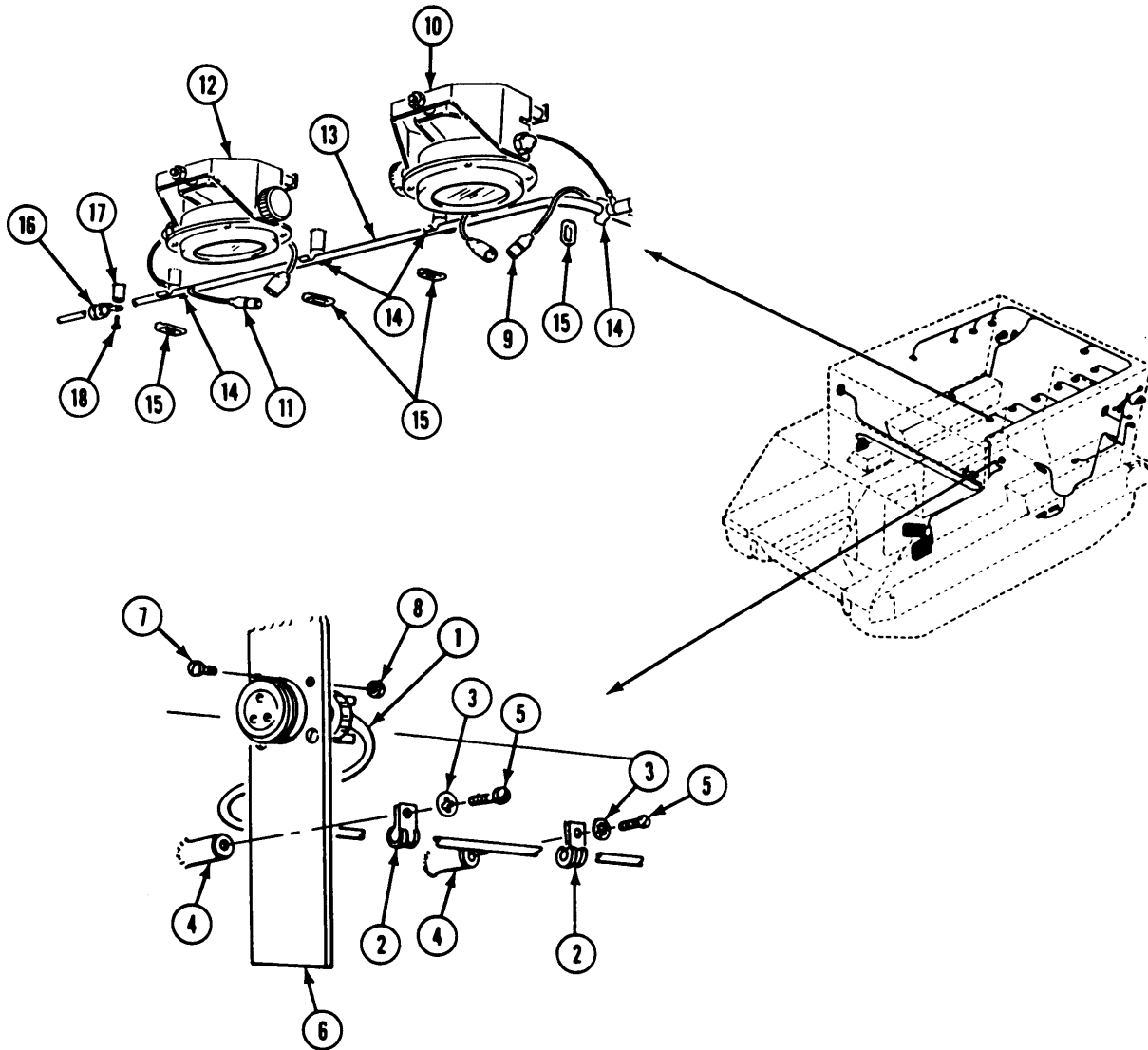

131. Pull circuits 21, 22, 23, 24, and 451 leads (1, 2, 3, 4, and 5) through opening in floor transverse beam (6).
132. Install clamp (7), two new lockwashers (8), trailer wiring harness ground lead (9), and rear main wiring harness (10) on weldnut (11). Secure with screw (12).
133. Connect circuit 451 lead (5) to rear bilge pump (13).
134. Connect circuits 21, 22, 23, and 24 leads (1, 2, 3, and 4) to trailer wiring harness (14).
135. Install clamp (15) on wiring harness (10). Secure with screw (16) and nut (17).
136. Install clamp (15) and wiring harness (10) on transverse beam (6). Secure with two screws (18) and nuts (19).
137. Install new lockwasher (20), clamp (21), and wiring harness (10) on weldnut (22). Secure with screw (23).

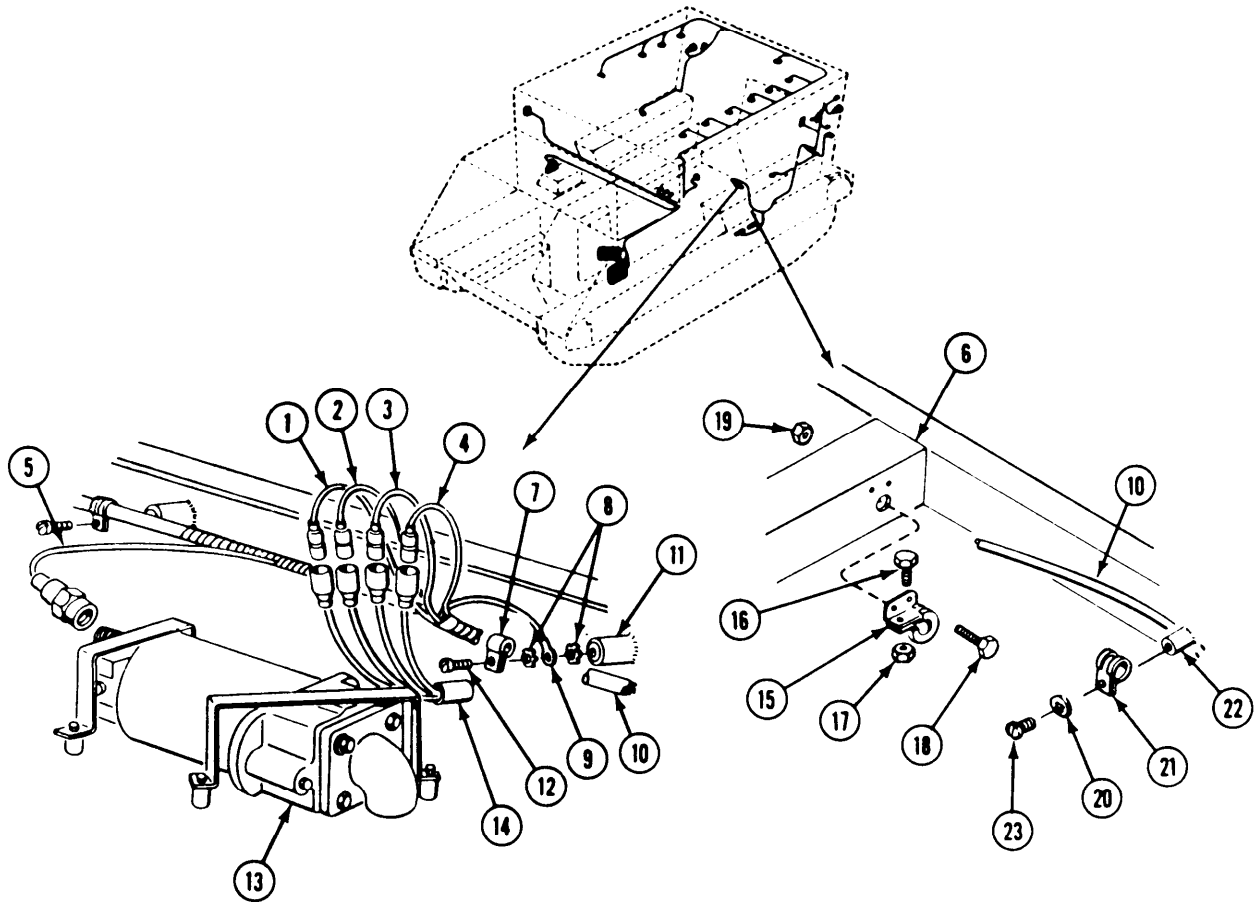

GO TO NEXT PAGE

- 138. Connect circuit 402 lead (1) to personnel heater fuel pump (2).
- 139. Install two clamps (3), one new lockwasher (4), circuit 30 lead (5), and ground lead (6) on two weldnuts (7). Secure with two screws (8).
- 140. Install new lockwire (9), one screw (10), new lockwasher (11), and ground lead 16 on left fuel quantity sending unit (12).
- 141. Connect circuit 30 lead (5) on sending unit (12).

- 142. connect circuit 509 lead (13) to buzzer (14).
- 143. Install one new lockwasher (15), two clamps (16), and circuits 30 and 509 leads (5 and 13) on two weldnuts (17). Secure with two screws (18).
- 144. Install wiring harness (19) on seven cradles (20). Secure with seven cradle clips (21).
- 145. Connect circuit 509 and 509A connector (22) to buzzer switch (23).

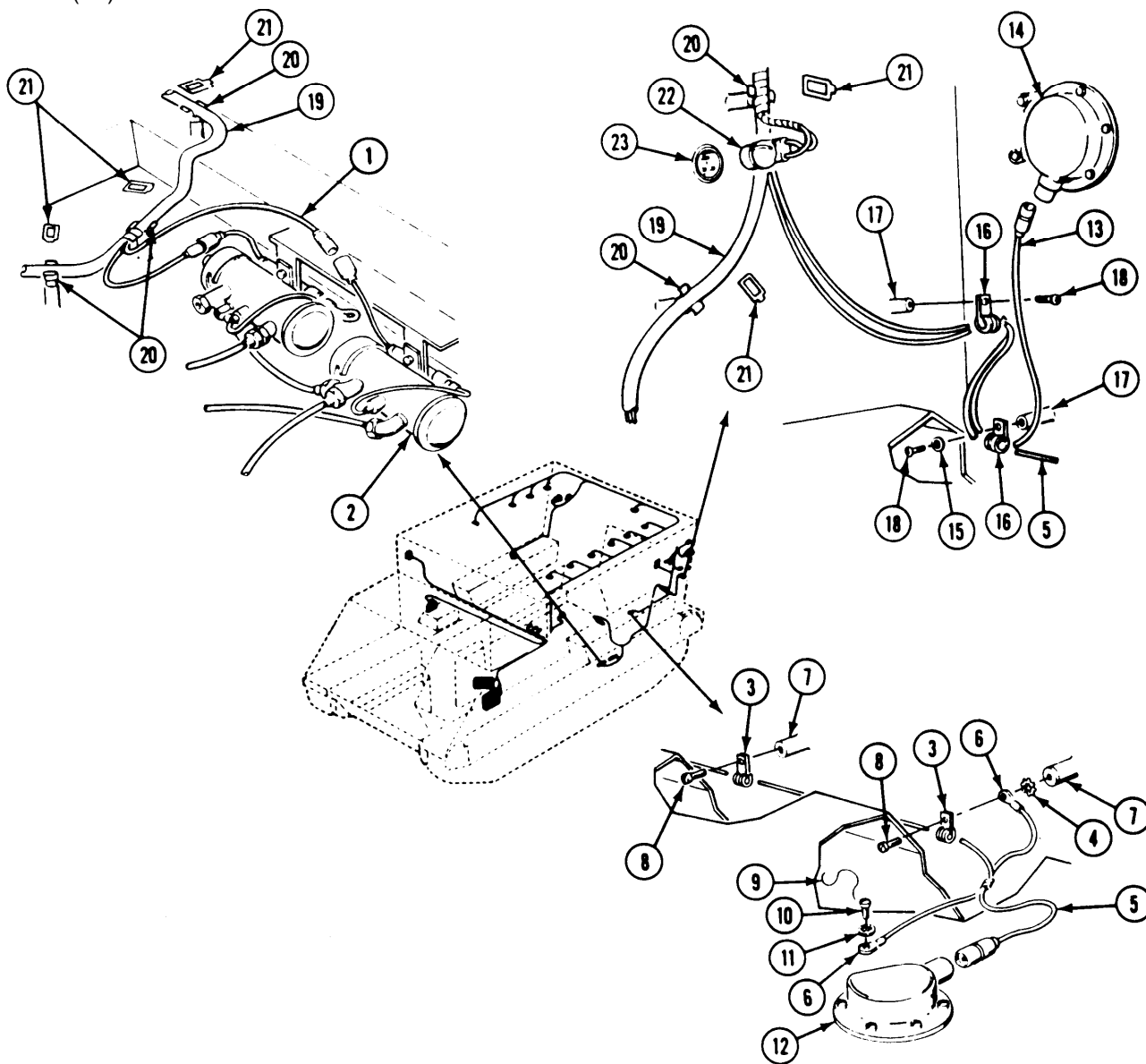

- 146. Connect circuits 38C and 38E leads (1 and 2) to blackout dome light switch (3).
- 147. Connect circuits 38, 38A, and 38E leads (4, 5, and 6) to dome light switch (7).
- 148. Connect circuits 21, 22, and 24 leads (8, 9, and 10) to left tail light leads (11).
- 149. Connect circuit 37B lead (12) to left utility outlet lead (13).
- 150. Install two circuit 48 connectors (23) on bracket (24). Secure with eight screws (14) and nuts (15).
- 151. Install two new lockwashers (16) and ground leads (17) on weldnut (18). Secure with screws (19).
- 152. Install wiring harness (20) on seven cradles (21). Secure with seven cradle clips (22).

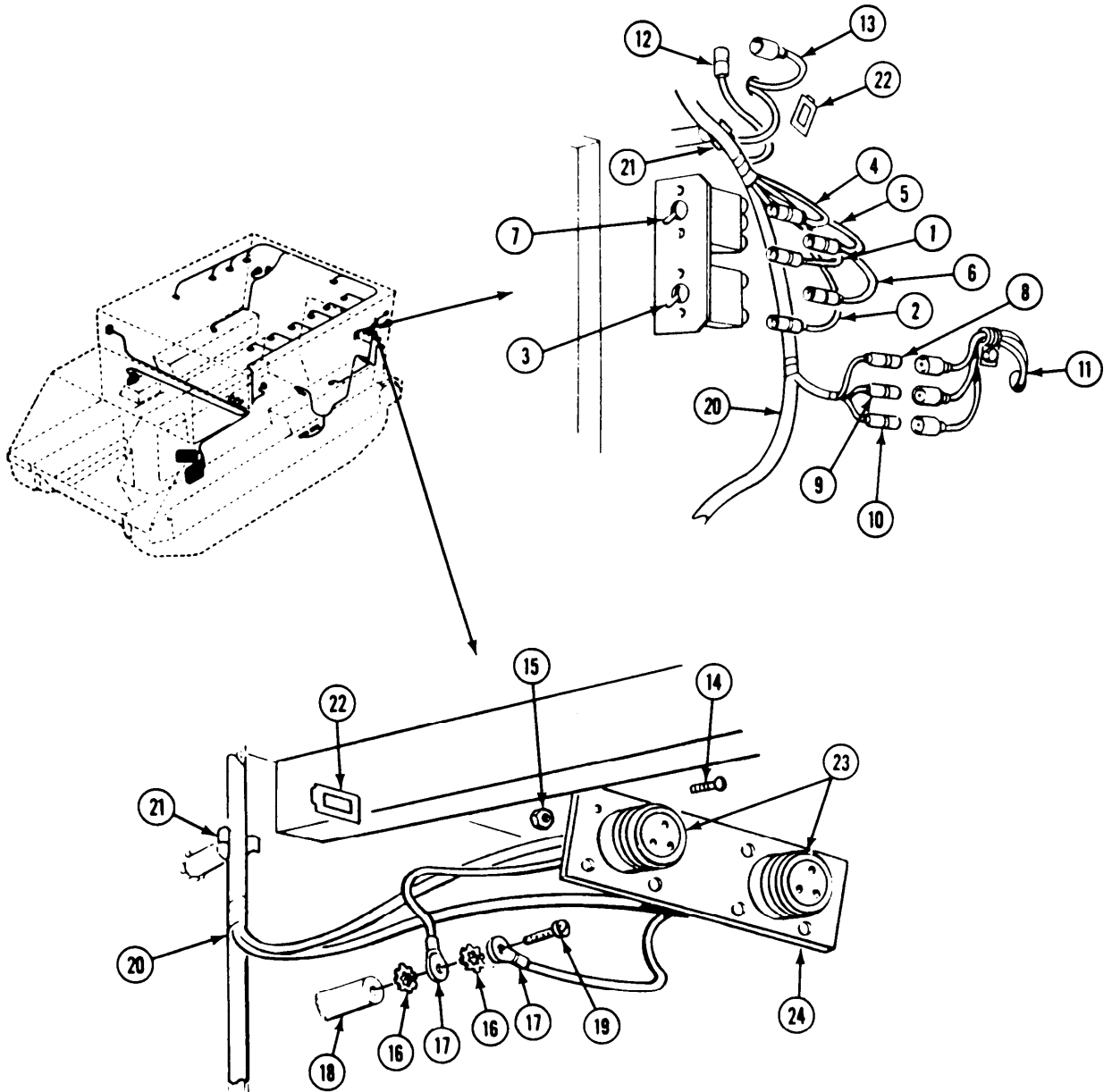

GO TO NEXT PAGE

- 153. Connect four circuit 38C leads (1) to four left side dome lights (2).
- 154. Install one new lockwasher (3), two clamps (4), circuit 38B lead (5), and ground lead (6) on two weldnuts (7). Secure with two screws (8).
- 155. Connect circuit 38B lead (5) to rear black-out dome light (9).

- 156. Install rear main wiring harness (10) on 16 cradles (11). Secure with 16 cradle clips (12).
- 157. Connect four circuit 38 leads (13) to four right side dome lights (14).
- 158. Install wiring harness (10) on eight cradles (15). Secure with eight cradle clips (16).

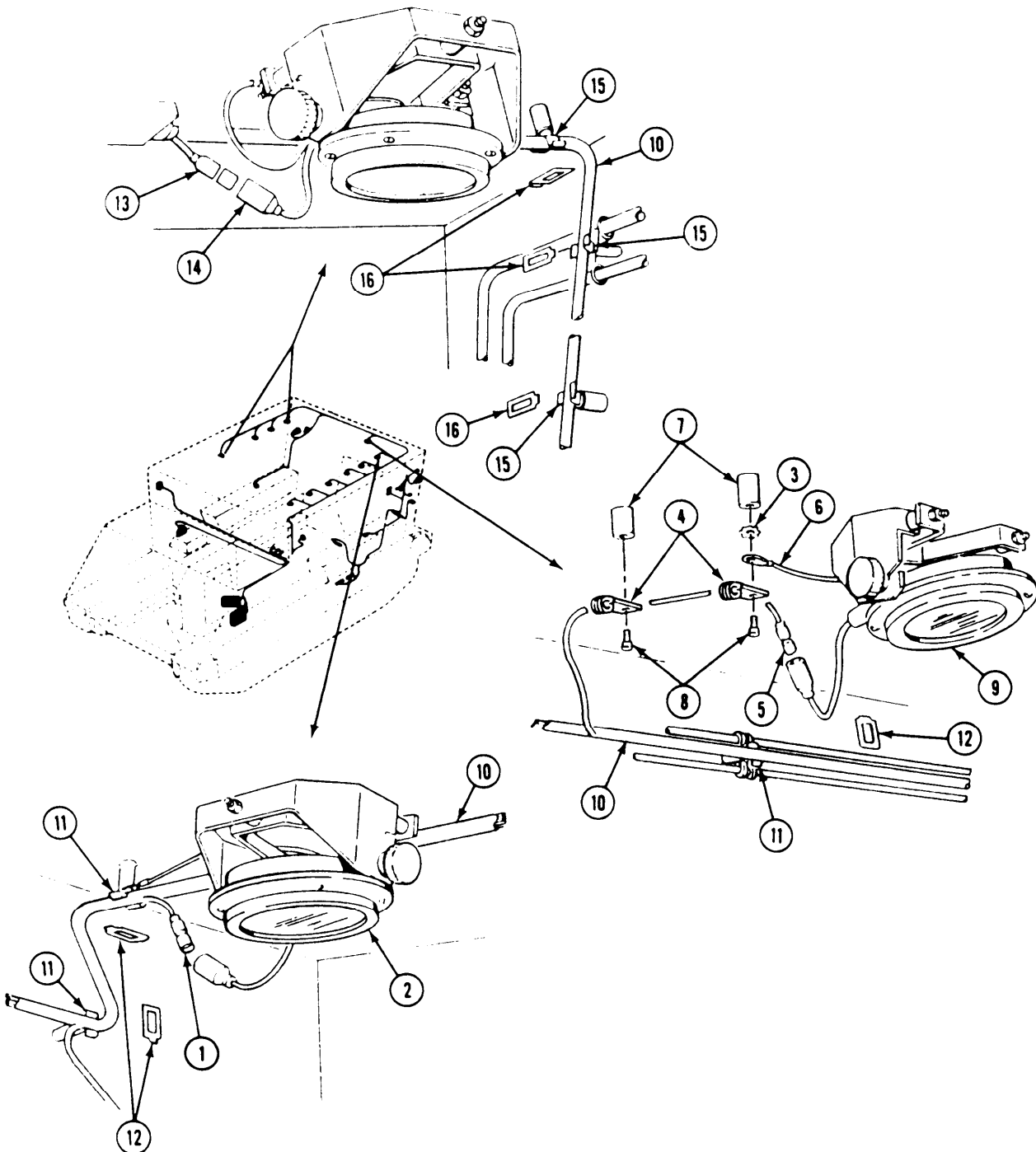

- 159. Connect circuit 37A lead (1) to right utility outlet lead (2).
- 160. If NBC unit is installed, connect circuit 415 lead (3) to NBC unit switch.
- 161. Connect circuits 23 and 24 leads (4 and 5) to right tail light (6).

- 162. Install two new lockwashers (7), ground lead (8), three clamps (9), and circuit 29 lead (10) on three weldnuts (11). Secure with three screws (12) and flat washers (13)
- 163. Install new lockwire (14), one screw (15), new lockwasher (16), and ground lead (8) on right fuel quantity sending unit (17).
- 164. Connect circuit 29 lead (10) on right fuel quantity sending unit (17).

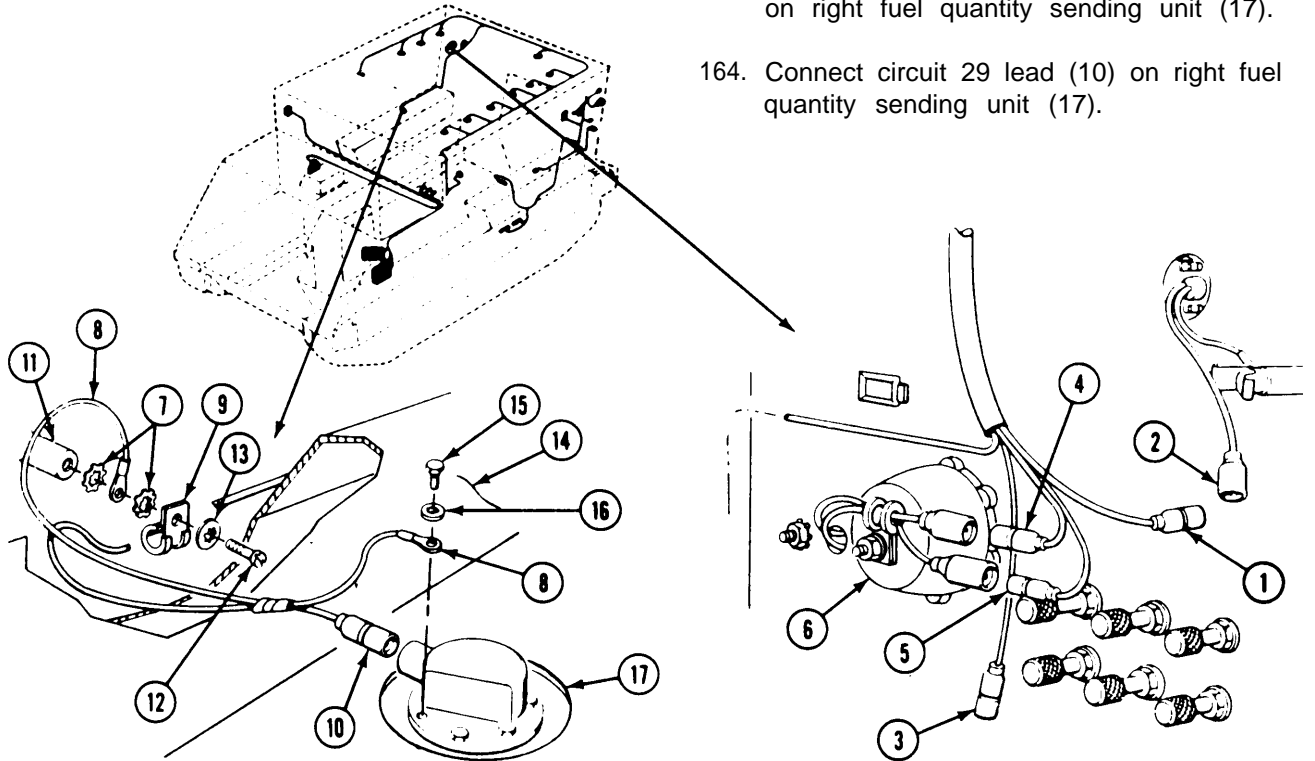

FOLLOW-THROUGH STEPS

- 1. Install rear floor plate (page 24-37).
- 2. Connect battery ground leads (page 13-2).
- 3. Turn MASTER SWITCH ON (See your -10).
Check that electrical system works properly.
- 4. Raise and lock ramp (see your -10).
- 5. Stop/shutdown engine (see your -10).

END OF TASK

REPLACE REAR MAIN WIRING HARNESS (M106A2 AND M125A2 ONLY)

DESCRIPTION

This task covers: Remove (page 12-106). Install (page 12-112).

INITIAL SETUP

Tools:

General Mechanics Tool Kit (Item 30, App D)

References:

See your -10

Materials/Parts:

Gasket
Grommet (5)
Lockwasher, as needed
Self-locking nut (8)
Terminal (3)

Equipment Conditions:

Engine stopped (see your -10)
Carrier blocked (see your -10)
Battery ground lead disconnected (page 13-2)
Ramp lowered (see your -10)
Rear floor plate removed (page 24-38)

Personnel Required:

Unit Mechanic

REMOVE

NOTE

Tag leads for later identification.

1. Disconnect circuits 23 and 24 leads (1 and 2) from right tail light (3).

2. Remove screw (4), nut (5), clamp (6), and rear main wiring harness (7) from bilge tube clamp (8).

3. Remove two screws (9), clamps (10), washers (11), and rear main wiring harness (12) from two weldnuts (13).

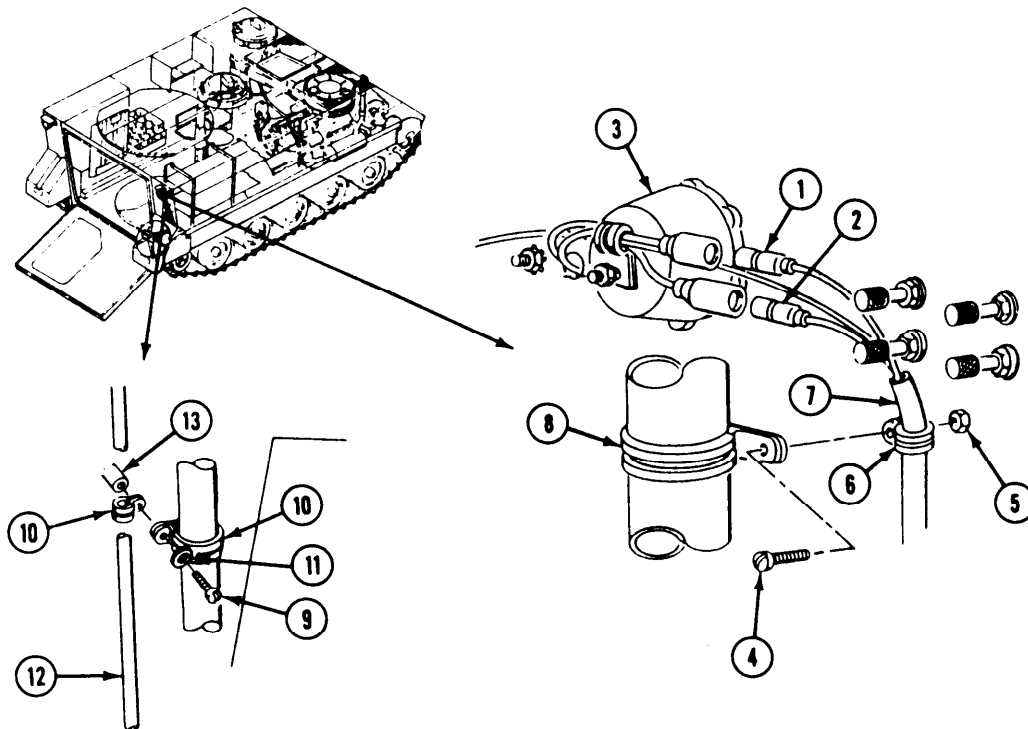

4. Disconnect circuit 451 lead (1) from rear bilge pump (2).
5. Disconnect circuits 21, 22, 23, and 24 leads (3, 4, 5, and 6) from trailer wiring harness (7).
6. Remove screw (8), two lockwashers (9), clamp (10), wiring harness (11), and circuit 90 ground lead (12) from weldnut (13). Discard lockwashers.
7. Remove two screws (14), nuts (15), and clamp (16) from floor transverse beam (17).
8. Remove screw (18), nut (19), and clamp (16) from wiring harness (20).
9. Remove three cradle clips (21) and wiring harness (20) from three cradles (22).
10. Remove two screws (23), lockwashers (24), and guard (25) from two weldnuts (26). Discard lockwashers.
11. Remove two screws (27), nuts (28), clamps (29), and wiring harness (20) from guard (25).

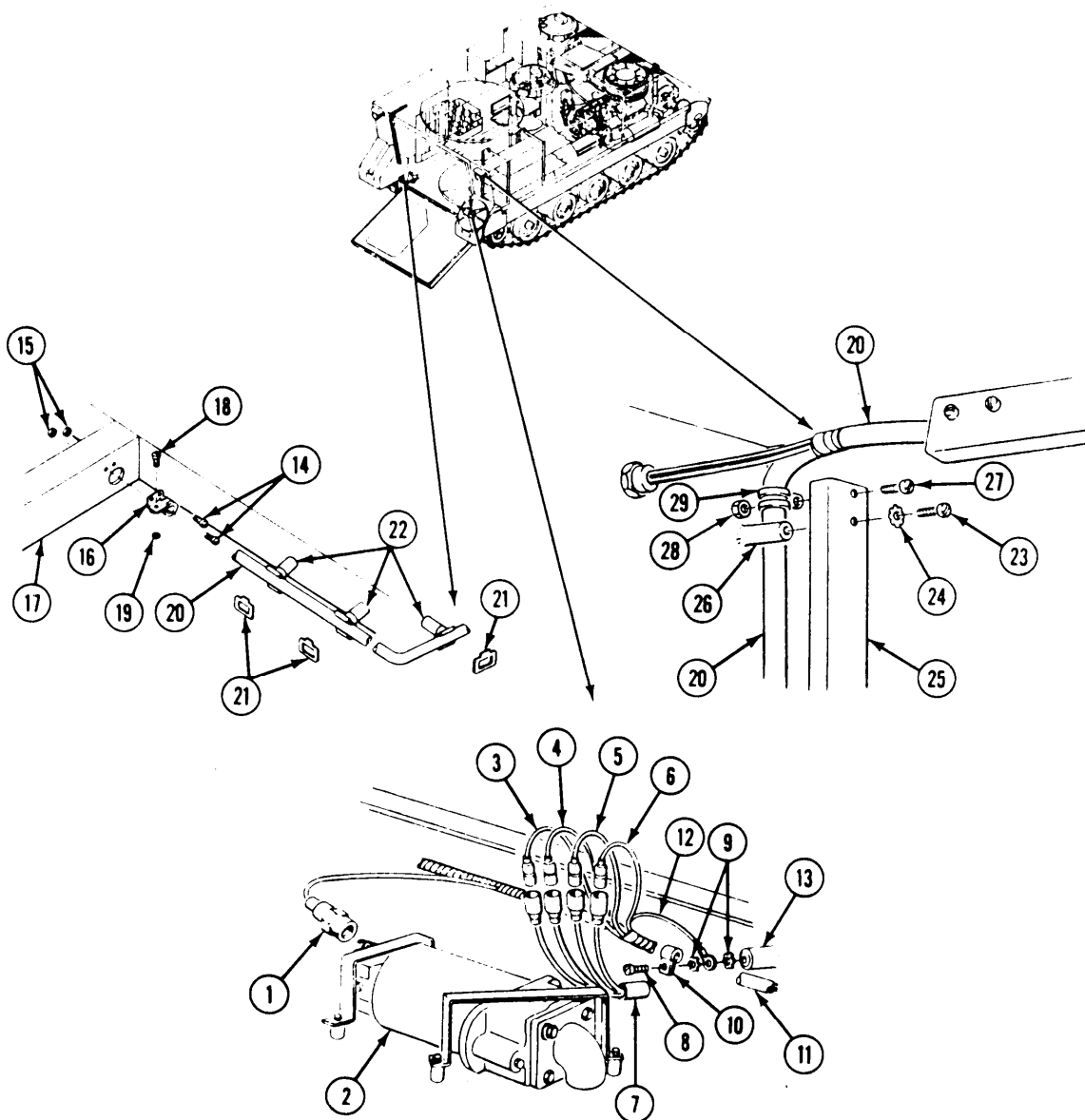

GO TO NEXT PAGE

12. Remove four screws (1), lockwashers (2), left tail light (3), and guard (4) from outside rear hull. Discard lockwashers.
13. Disconnect circuits 21, 22, and 24 leads (5, 6, and 7) from left tail light (3). Remove nut (8) and bushing (9) from connector (10).
14. Remove three terminals (11), insulators (12), and connectors (13) from three leads (5, 6, and 7). Discard terminals.
15. Pull leads (5, 6, and 7) through connector (10) with bushing (9) and nut (8).
16. Remove nut (8) and bushing (9) from leads (5, 6, and 7).
17. Remove three screws (14), lockwashers (15), and guard (16) from three weldnuts (17). Discard lockwashers.
18. Remove three screws (18), nuts (19), clamps (20), and rear main wiring harness (21) from guard (16).
19. Remove two cradle clips (22) and wiring harness (23) from two cradles (24).
20. Disconnect circuit 28 lead (25) from fuel quantity sending unit (26).
21. Remove screw (27), clamp (28), and wiring harness (23) from weldnut (29).
22. Remove four cradle clips (30) and wiring harness (23) from four cradles (31).

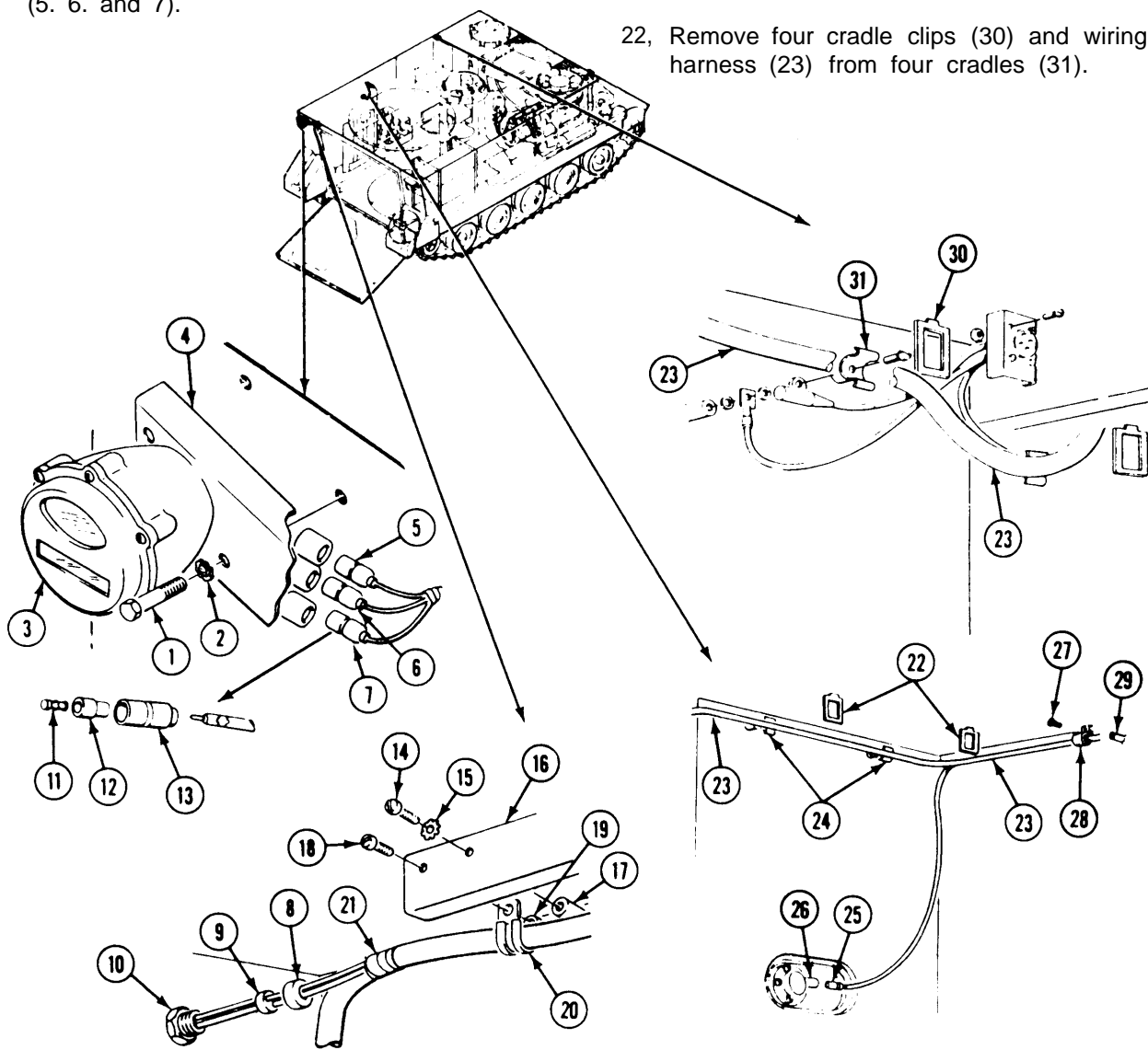

23. Remove screw (1), one cradle (2), two lockwashers (3), circuit 48 connector ground lead (4), and capacitor (5) from weldnut (6),
24. Disconnect circuit 48 lead (7) from capacitor (5).
25. Remove four screws (8), nuts (9), and circuit 48 connector (10) from bracket (11).

26. Disconnect circuit 38 lead (12) from dome light (13).
27. Remove three screws (14), lockwashers (15), clamps (16), and circuit 38 lead (12) from three weldnuts (17). Discard lockwashers.
28. Attach a cord (18) to circuit 38 lead (12). Pull lead through transverse beam (19) into driver's compartment. Untie cord from lead and leave it in transverse beam.
29. If personnel heater is installed, disconnect circuit 400 lead (20) from heater control box lead.
30. If engine coolant heater is installed, disconnect circuit 400A lead (21) from engine coolant heater control box lead.
31. Remove three cradle clips (22) and rear main wiring harness (23) from three cradles (24) in driver's compartment.

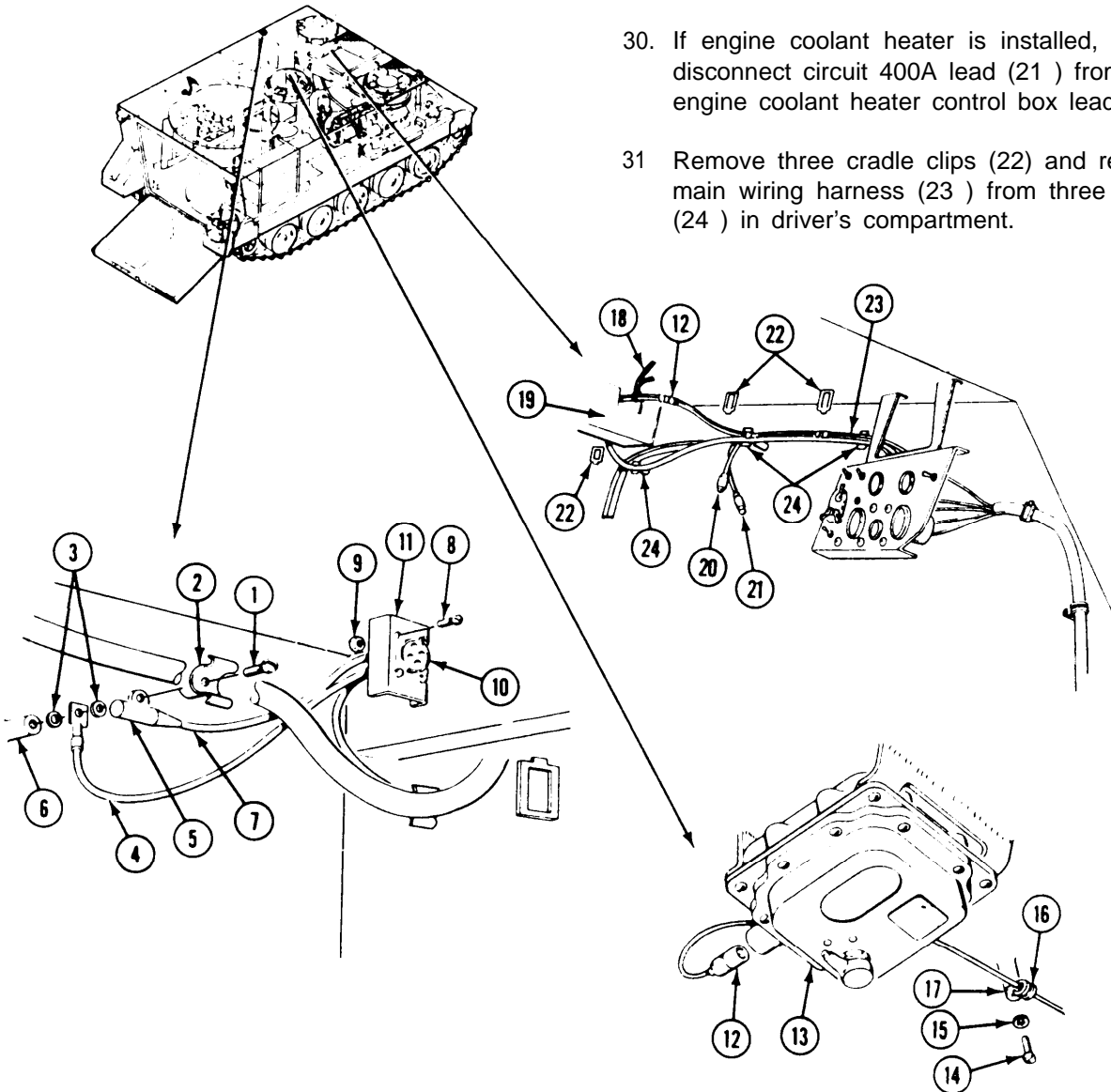

GO TO NEXT PAGE

- 32. Remove eight screws (1), washers (2), and locknuts (3). Separate master switch panel (4) from distribution box (5). Discard locknuts.
- 33: Remove nut (6), screw (7), and circuits 6, 2, and 400 leads (8, 9, and 10) from bus bar (11).
- 34. Disconnect circuit 38 lead (12) from circuit 37 lead (13).

- 35. Remove circuit 400 lead (14) and grommet (15) from distribution box (16). Discard grommet.
- 36. Disconnect circuit 450 lead (17) from circuit breaker (18).
- 37. Remove circuit 450 lead (17) and grommet (19) from distribution box (16). Discard grommet.
- 38. Disconnect circuit 450B lead, (20) from circuit breaker (21).
- 39. Remove circuit 450B lead (20) and grommet (22) from distribution box (16). Discard grommet.

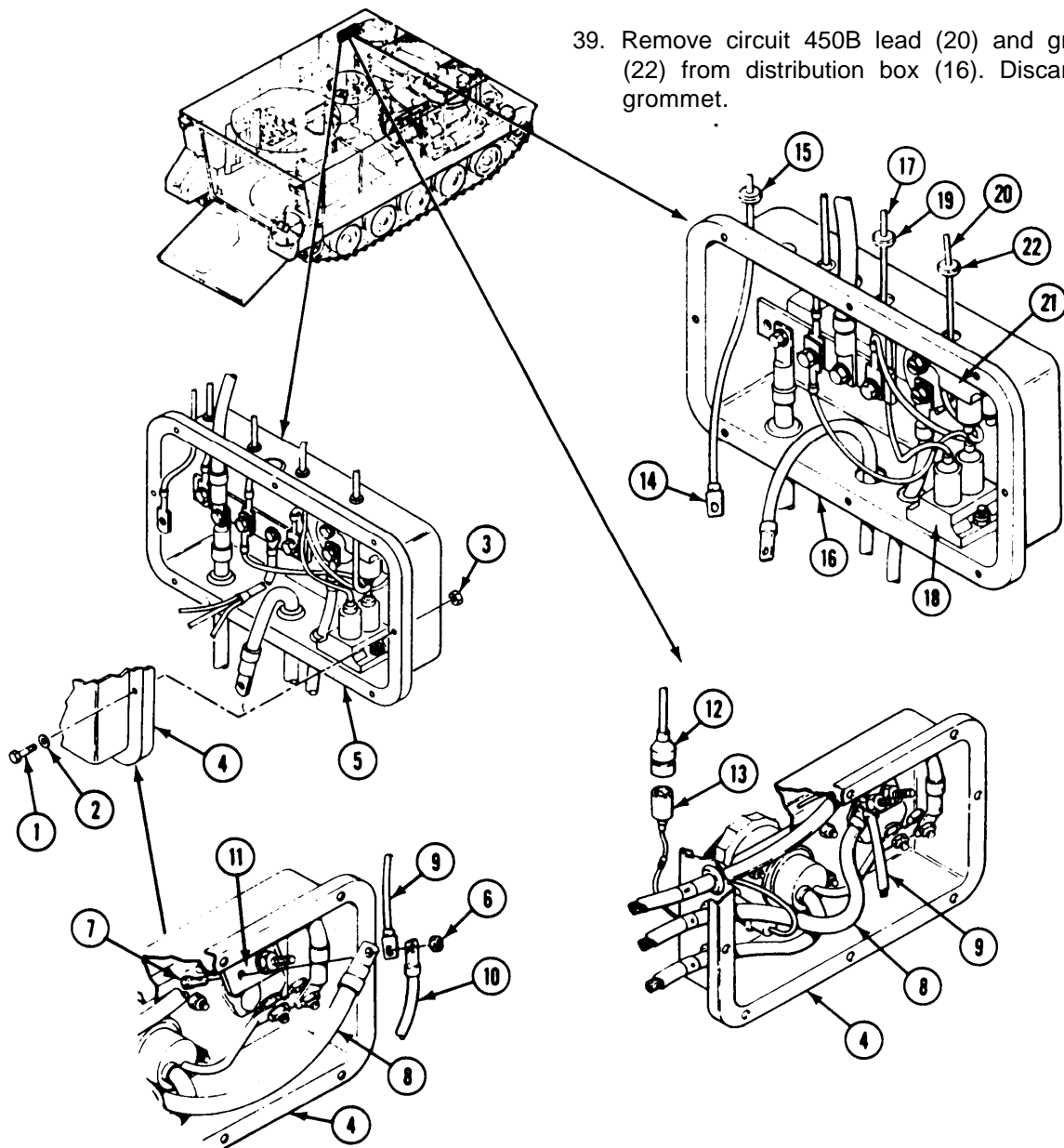

40. Remove two nuts (1), mounts (2 and 3), flat washers (4), and screws (5) that secure instrument panel (6) to two struts (7).
41. Support panel (6). Remove two screws (8), flat washers (9), one lockwasher (10), and ground lead (11) from two mounts (12) and upper support (13). Discard lockwasher.
42. Support panel (6) on two struts (7) to gain access to rear of instrument panel.
43. Disconnect circuit 28 lead (14) from fuel gage.
44. Disconnect circuit 451B lead (15) from rear bilge pump ON indicator light.
45. Disconnect circuit 38 lead (16) from instrument panel wiring harness.
46. Disconnect circuits 450, 450B, and 451A leads (17, 18, and 19) from Bilge pump switch.
47. Disconnect circuits 21, 22, 23, and 24 leads (20, 21, 22, and 23) from front main wiring harness.

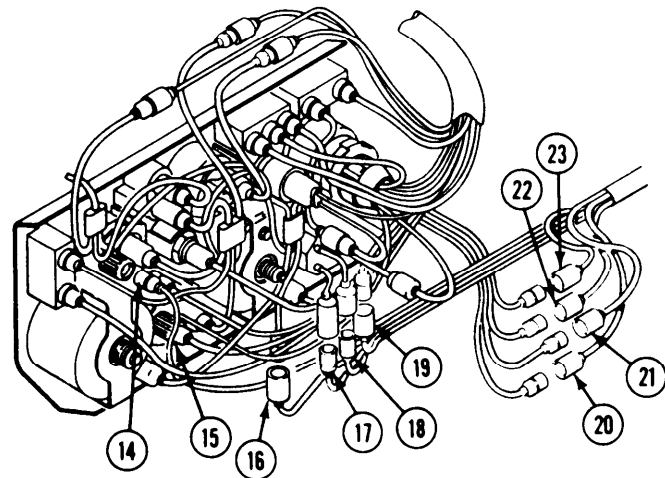
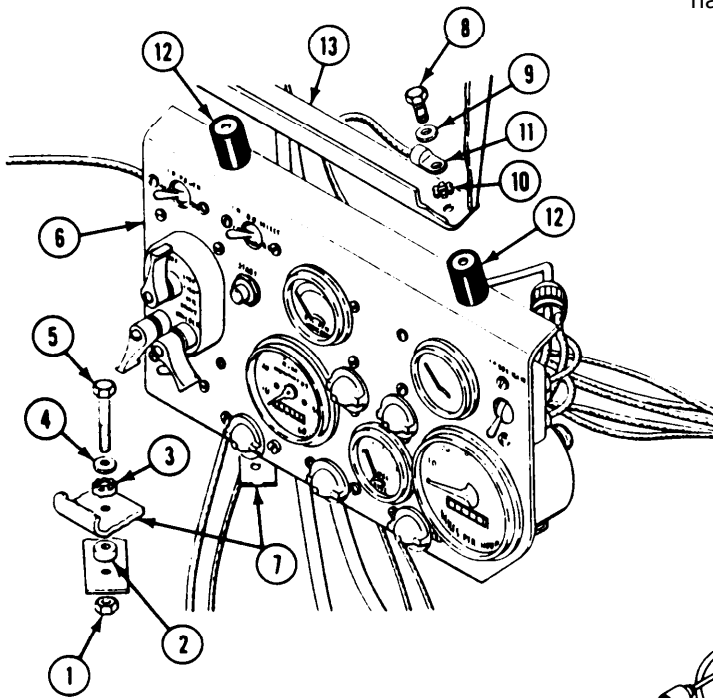

GO TO NEXT PAGE

48. Lower left crew seat backrest. Turn handle (1) and pull battery drawer (2) out.
49. Remove screw (3), nut (4), and circuits 6 and 48 leads (5 and 6) from battery terminal (7).
50. Remove circuit 48 lead (6) and two grommets (8) from battery box (9). Discard grommets.
51. Remove rear main wiring harness from carrier.

INSTALL

52. Install r-ear main wiring harness in carrier.
53. Install circuit 48 lead (6) and two new grommets (8) in battery box (9).
54. Install circuits 6 and 48 leads (5 and 6) on battery terminal (7). Secure with screw (3) and nut (4).
55. Push battery drawer (2) in. Turn handle (1) to lock drawer. Raise left crew seat backrest.

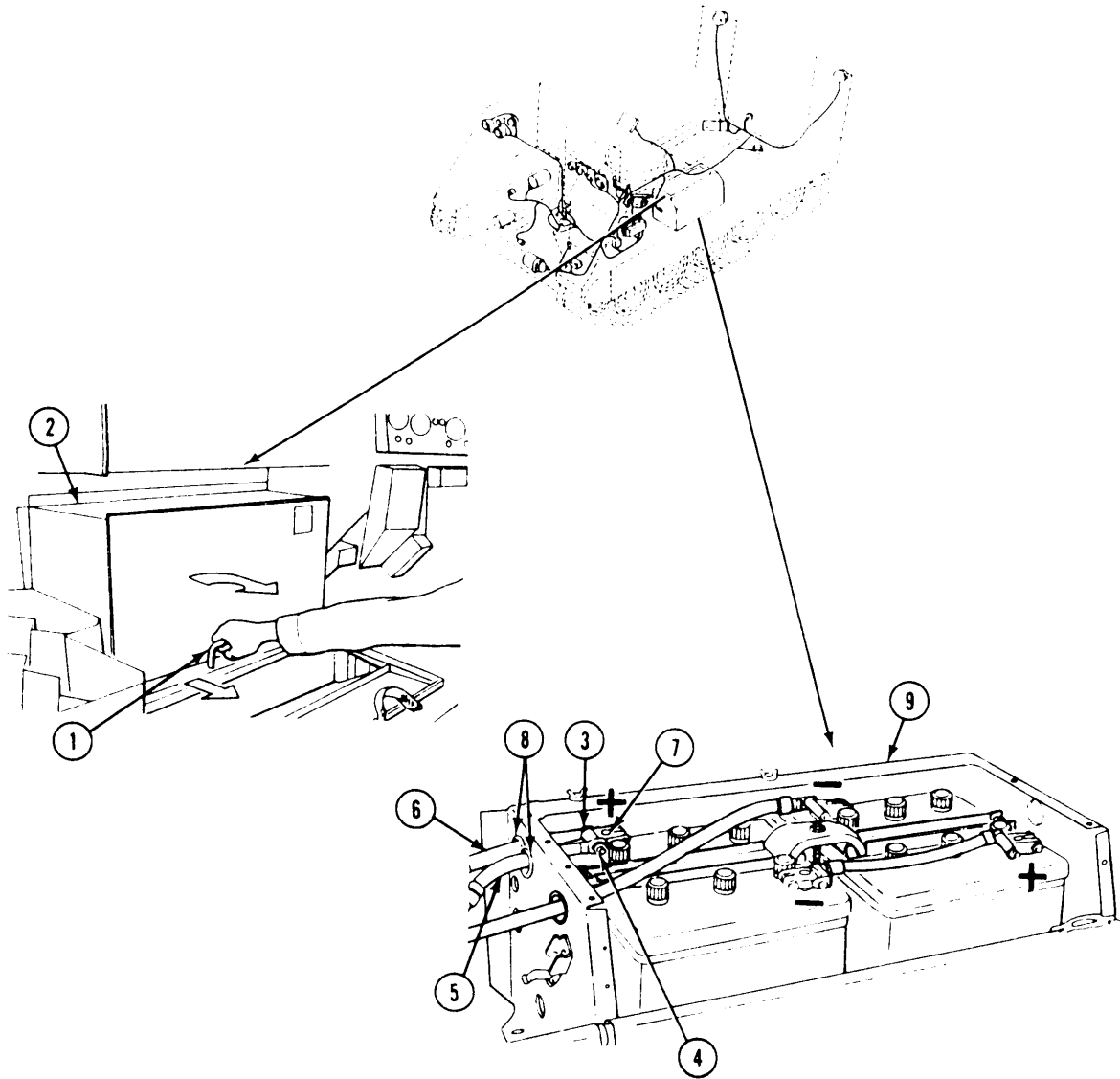

56. Connect circuits 21, 22, 23, and 24 leads (1, 61. Support instrument panel (11) on two struts (12).
57. Connect circuits 450, 450B, and 451A leads (5, 6, and 7) to bilge pump switch.
58. Connect circuit 38 lead (8) to instrument panel wiring harness.
59. Connect circuit 451B lead (9) to rear bilge pump on indicator light.
60. Connect circuit 28 lead (10) to fuel gage,
62. Install ground lead (13) and new lockwasher (14) on upper support (15). Install panel (11) with two mounts (16) on support (15). Secure with two screws (17) and flat washers (18).
63. Install panel (11) on two struts (12). Secure with two nuts (19), mounts (20 and 21), flat washers (22), and screws (23).

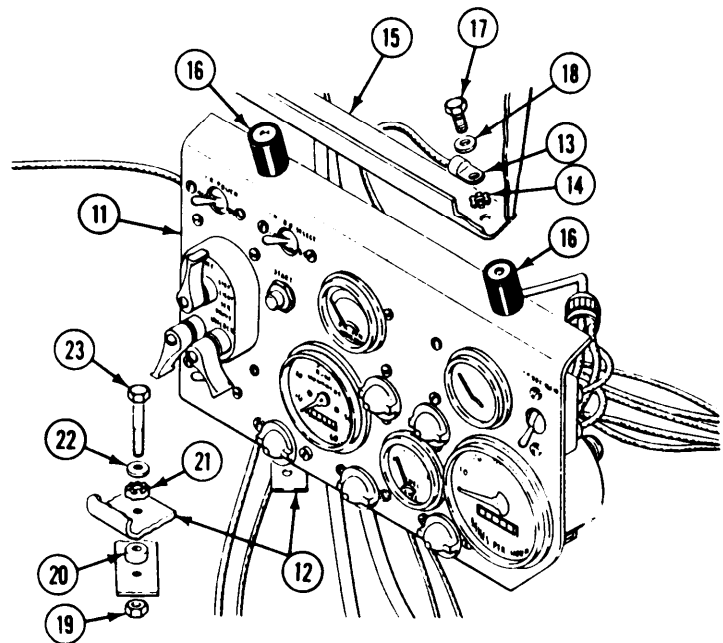
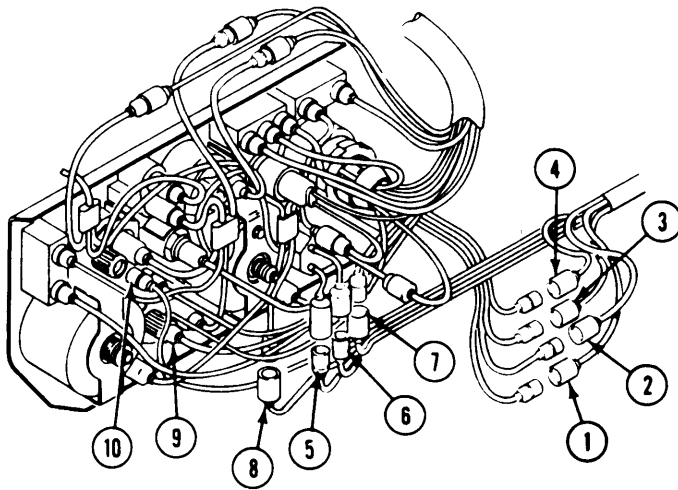

GO TO NEXT PAGE

- 64. Install circuit 450B lead (1) and new grommet (2) in distribution box (3).
- 65. Connect circuit 450B lead (1) to circuit breaker (4).
- 66. Install circuit 450 lead (5) and new grommet (6) in distribution box (3).
- 67. Connect circuit 450 lead (5) to circuit breaker (7).
- 68. Install circuit 400 lead (8) and new grommet (9) in distribution box (3).

- 69. Connect circuit 38 lead (10) to circuit 37 lead (11).
- 70. Install circuits 6, 2, and 400 leads (12, 13, and 14) on bus bar (15). Secure with nut (16) and screw (17).
- 71. Install master panel (18) on distribution box (3). Secure with eight screws (19), washers (20), and new locknuts (21).

NOTE

Inspect gasket (22). Replace if damaged.

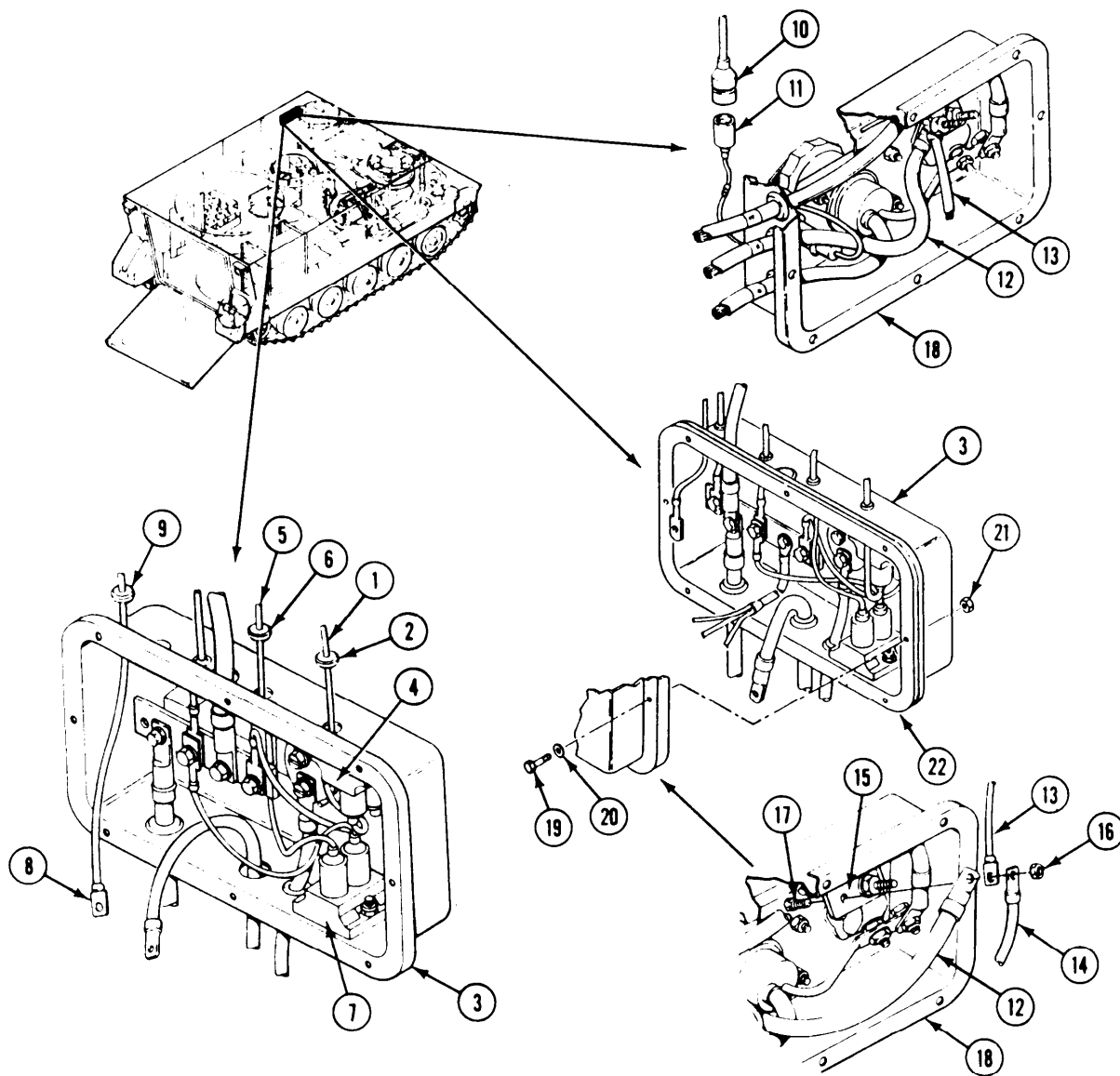

72. Install rear main wiring harness (1) on three cradles (2) in driver's compartment. Secure with three cradle clips (3).
73. If engine coolant heater is installed, connect circuit 400A lead (4) to engine coolant heater control box lead.
74. If personnel heater is installed, connect circuit 400 lead (5) to heater control box lead.
75. Attach cord, left in transverse beam (6), to circuit 38 lead (7). Pull lead through transverse beam into personnel compartment. Untie cord from lead.
76. Install new lockwashers (8), clamps (9), and circuit 38 lead (7) on three weldnuts (10), Secure with three screws (11).
77. Connect circuit 38 lead (7) to dome light (12).
78. Install circuit 48 connector (13) on bracket (14). Secure with four screws (15) and nuts (16).
79. Connect circuit 48 lead (17) to capacitor (1 S).
80. Install one cradle (19), two new lockwashers (20), circuit 48 connector ground lead (21), and capacitor (18) on weldnut (22). Secure with screw (23).
81. Install rear main wiring harness (24) on four cradles (19). Secure with four cradle clips (25).

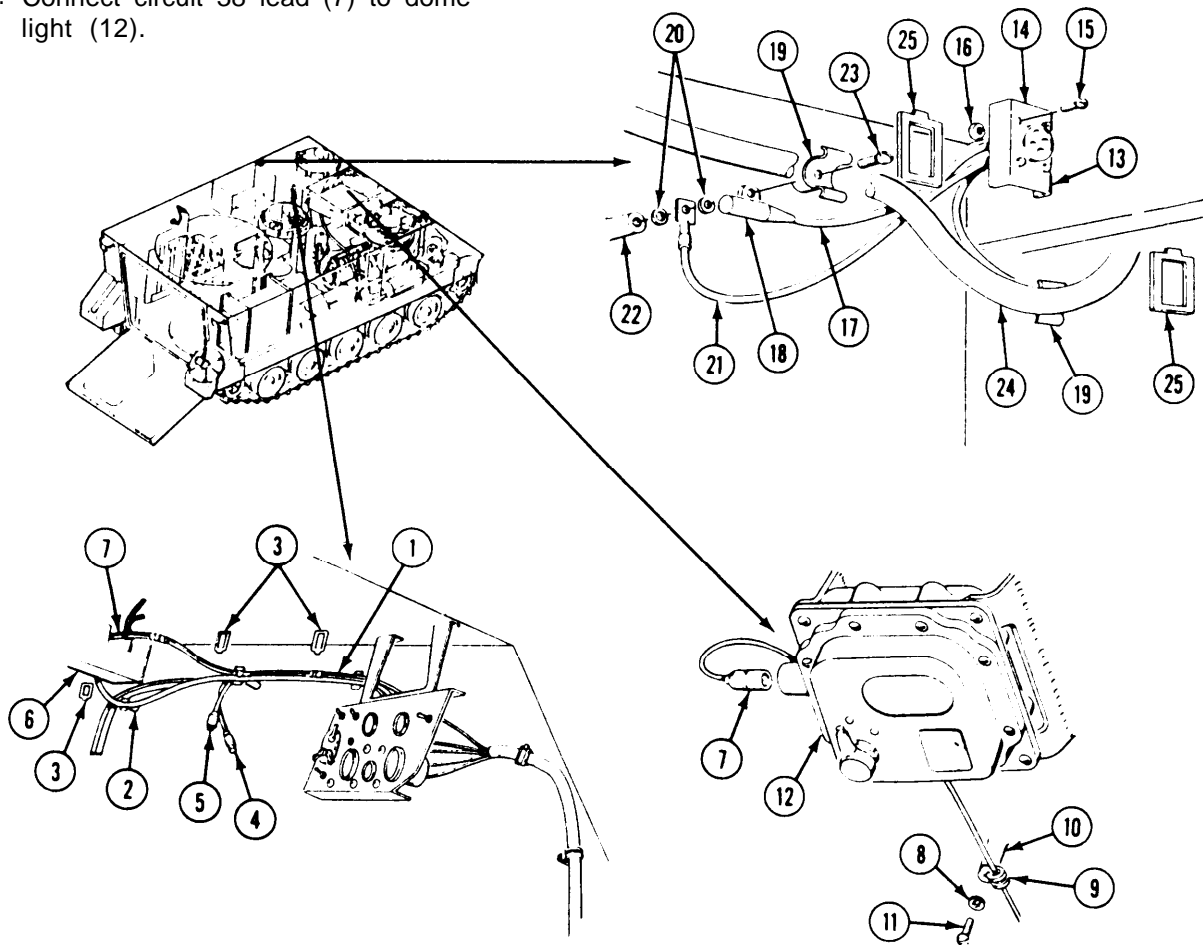

GO TO NEXT PAGE

82. Install clamp (1) and wiring harness (2) on weldnut (3). Secure with screw (4).

83. Connect circuit 28 lead (5) to fuel quantity sending unit (6).

84. Install wiring harness (2) on two cradles (7). Secure with two cradle clips (8).

85. Install wiring harness (9) on guard (10). Secure with three screws (11), three nuts (12), and three clamps (13).

86. Install guard on three weldnuts (14). Secure with three screws (15) and new lockwashers (16).

87. Install nut (17) and bushing (18) on leads (19, 20, and 22).

88. Pull leads (19, 20, and 21) through connector (22). Secure with bushing (18) and nut (17),

89. Install three new terminals (23), insulators (24), and connectors (25) on three leads (19, 20, and 21).

90. Connect circuits 21, 22, and 24 leads (19, 20, and 21) to left tail light (26).

91. Install left tail light (26) and guard (27) on outside rear of hull. Secure with four screws (28) and new lockwashers (29).

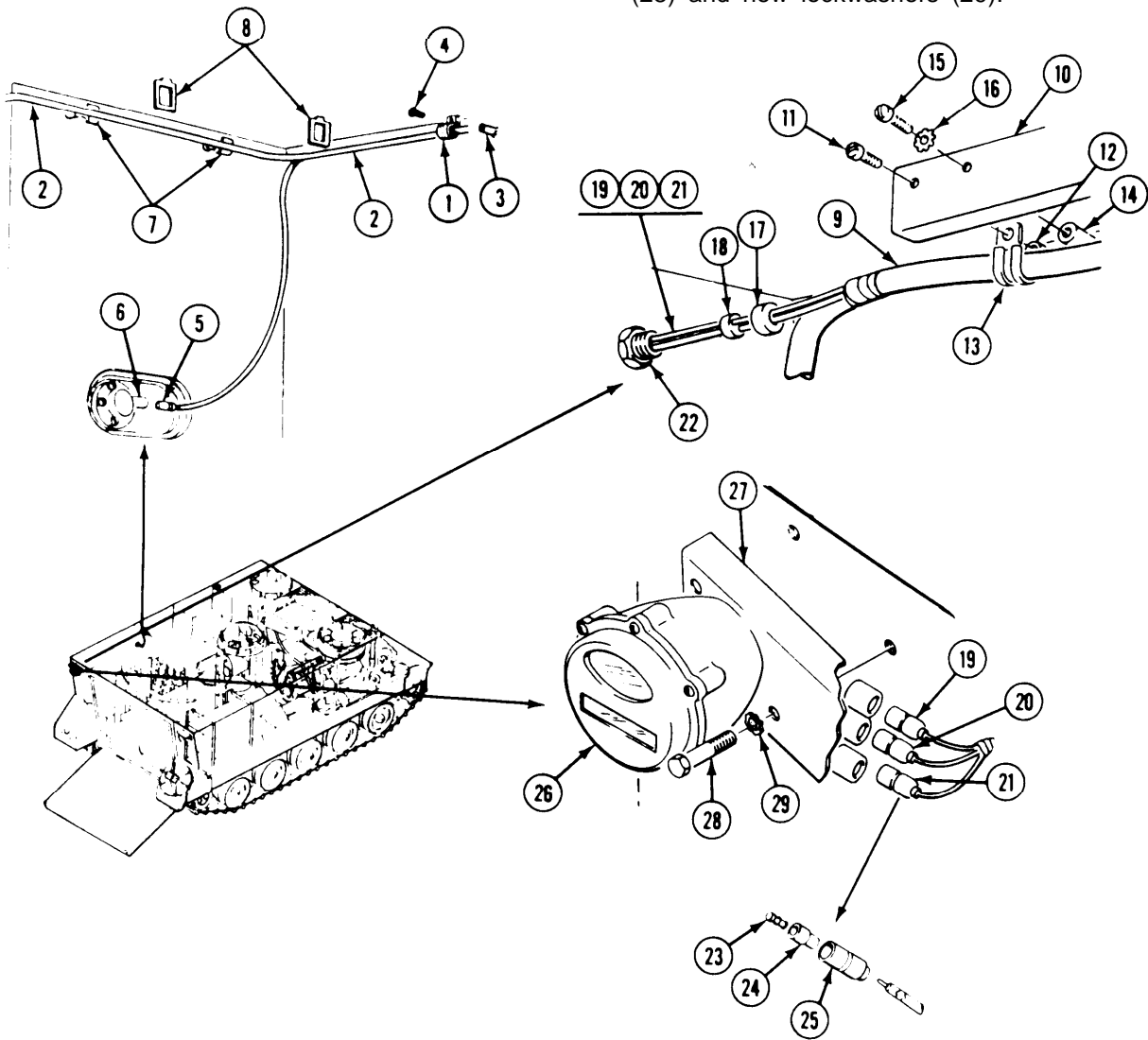

92. Install rear main wiring harness (1) on guard (2). Secure with two screws (3), nuts (4), and clamps (5).
93. Install guard (2) on two weldnuts (6). Secure with two screws (7) and new lockwashers (S).
94. Install wiring harness (1) on three cradles (9). Secure with three cradle clips (10).
95. Install screw (11), nut (12), and clamp (13) on wiring harness (1).
96. Install two screws (14), nuts (15), and clamp (13) on floor transverse beam (16).
97. Install two new lockwashers (17), clamp (18), wiring harness (19), and circuit 90 ground lead (20) on weldnut (21). Secure with screw (22).
98. Connect circuits 21, 22, 23, and 24 leads (23, 24, 25, and 26) to trailer wiring harness (27).
99. Connect circuit 451 lead (28) to rear bilge pump (29).
100. Install wiring harness (19) on two weldnuts (30). Secure with two screws (31), clamps (32), and washers (33).

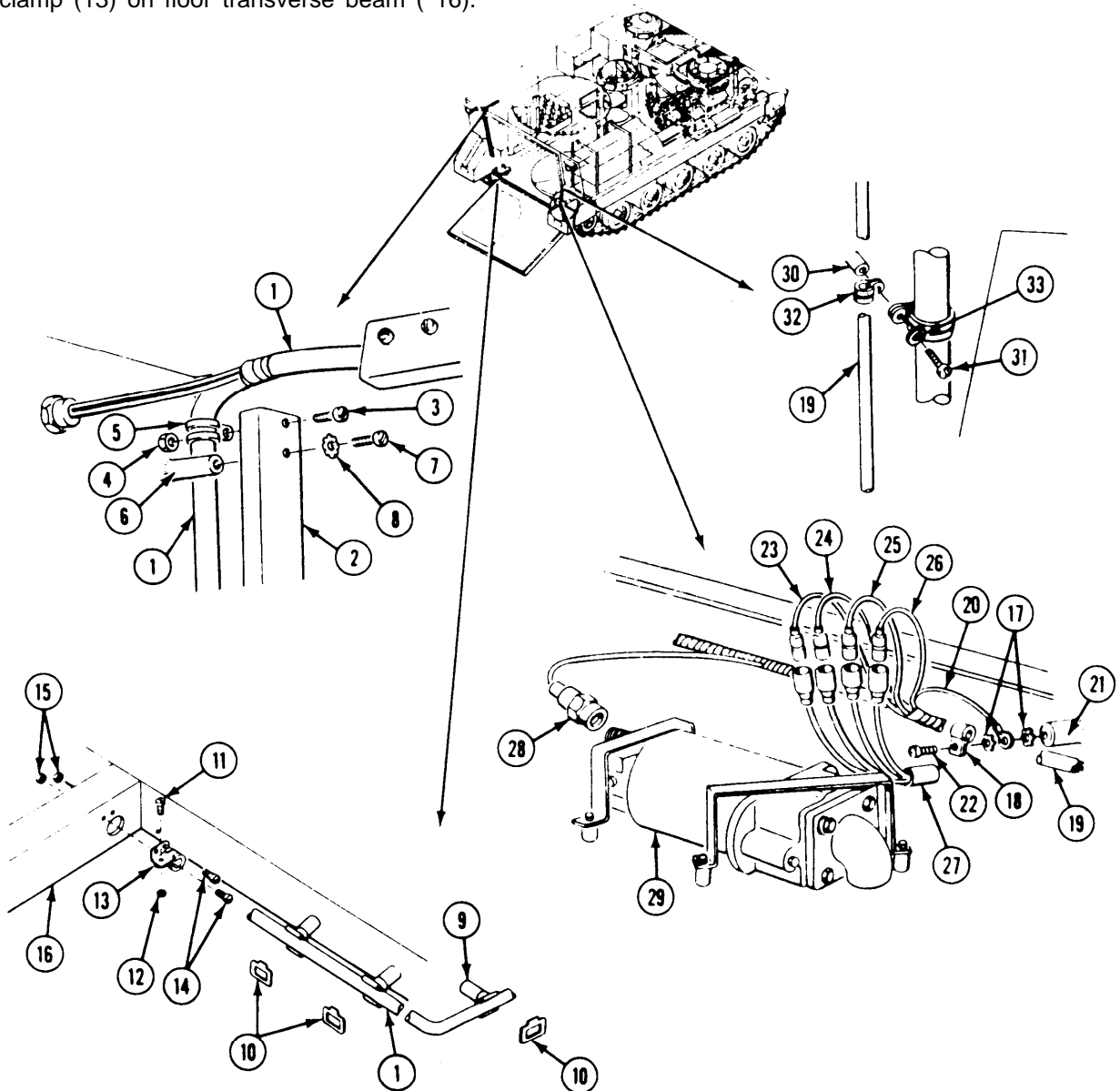

GO TO NEXT PAGE

101. Install clamp (1) and rear main wiring harness (2) on bilge pump tube clamp (3). Secure with screw (4) and nut (5).

102. Connect circuits 23 and 24 leads (6 and 7) to right tail light (8).

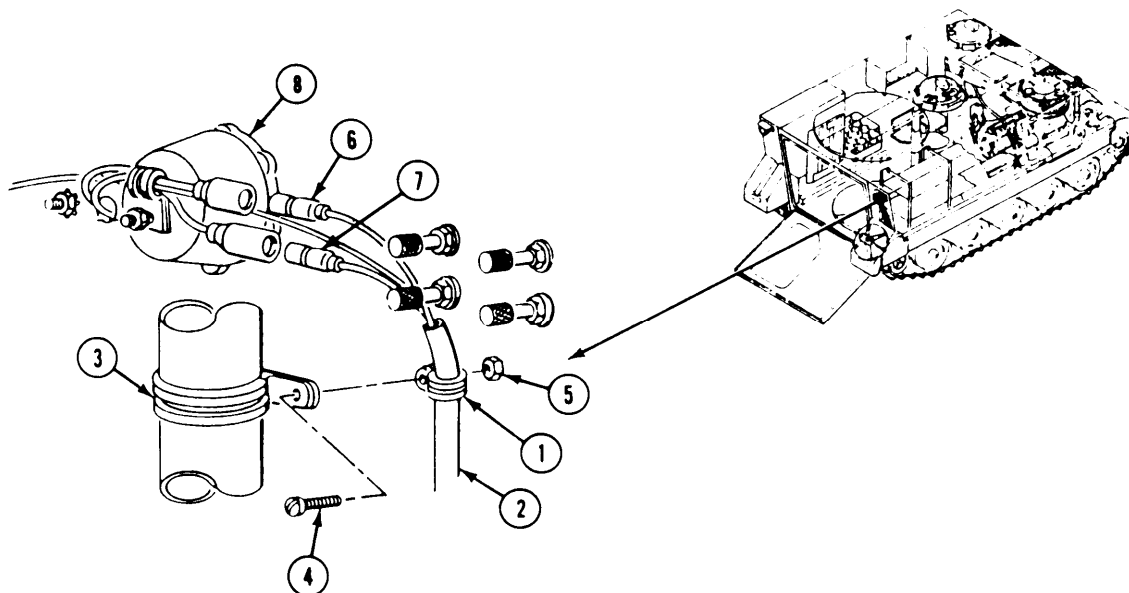

FOLLOW-THROUGH STEPS

1. Install rear floor plate (page 24-38).
2. Connect battery ground lead (page 13-2).
3. Turn MASTER SWITCH ON (see your -10).
Check that electrical system works properly.
4. Raise and lock ramp (see your -10).
5. Stop engine (see your -10).

END OF TASK

REPLACE REAR MAIN WIRING HARNESS (M1064 ONLY)

DESCRIPTION

This task covers: Remove (page 12-118. 1). Clean, Inspect, and Repair (page 12-118.11).
Install (page 12-118.11).

INITIAL SETUP

Tools:

General Mechanics Tool Kit (Item 30, App D)
Multimeter (Item 43, App D)

Materials/Parts:

Insulation tape (Item 26, App C)
Twine (Item 57.1, App C)
Grommet (4)
Lockwasher (36)
Self-locking nut (21)

Personnel Required:

Unit Mechanic

References:

See your -10

Equipment Conditions:

Engine stopped (see your -10)
Carrier blocked (see your -10)
Battery ground lead disconnected (page 13-2)
Ramp lowered (see your -10)
Rear floor plate removed (page 24-38)

REMOVE

NOTE

Tag leads before removal.

1. Remove two screws (1), lockwashers (2), washers (3), and harness guard (4) from top of right fuel tank (5). Discard lockwashers.
2. Disconnect circuit 23 and 24 leads (6 and 7) from right tail light leads (8 and 9).
3. Disconnect circuit 31 lead (10) from fuel transmitter lead (11) on right fuel tank (5).

4. Remove two screws (12), lockwashers (13), washers (14), and harness bracket (15) from top of right fuel tank (5). Discard lockwashers.
5. Remove screw (16), lockwasher (17), washer (18), and harness guard (19) from top of rear hull. Discard lockwasher.
6. Pull harness (20) through hole in rear plate (21).

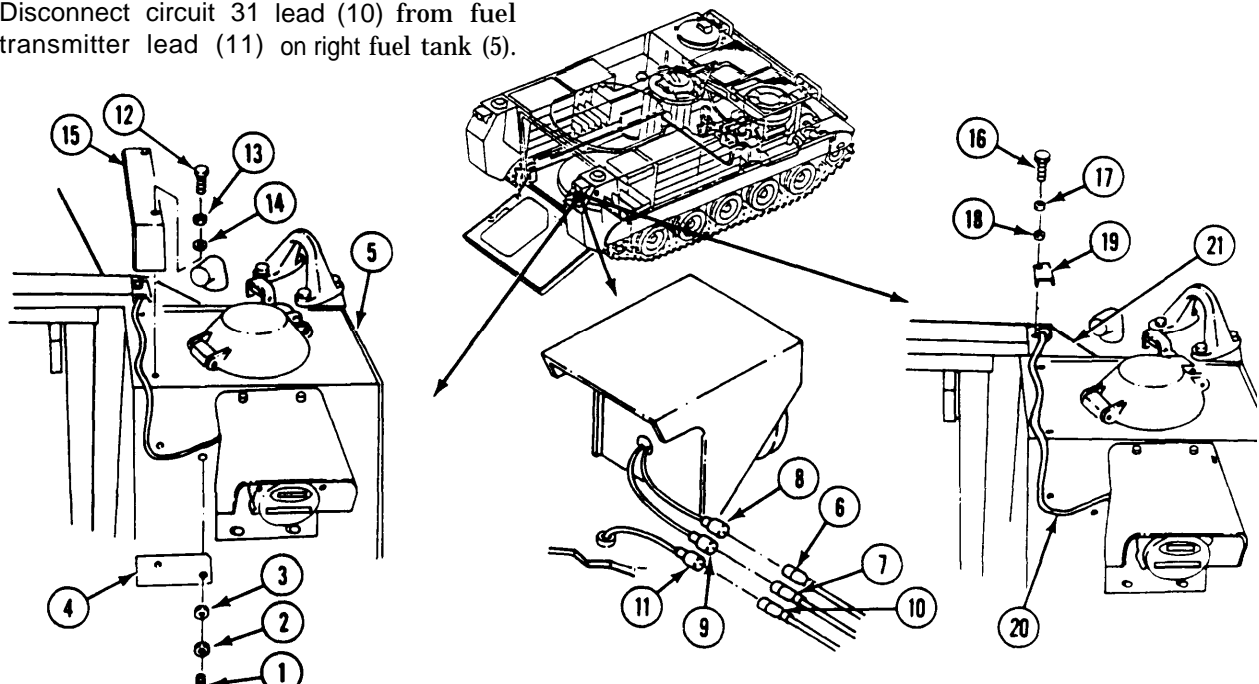

GO TO NEXT PAGE

7. Remove nut (1), washer (2), and rubber bushing (3) around harness (4) from connector (5).
8. Remove connector (5) from hull.
9. Pull harness (4) through hole in hull top. Leave connector (5), rubber bushing (3), washer (2), and nut (1) on harness.

10. Remove screw (6), locknut (7), clamp (8), and harness (4) from upper bilge tube clamp (9). Discard locknut.
11. Remove two screws (10), lockwashers (11), clamps (12), and harness (4) from two lower bilge tube clamps (13). Discard lockwashers.

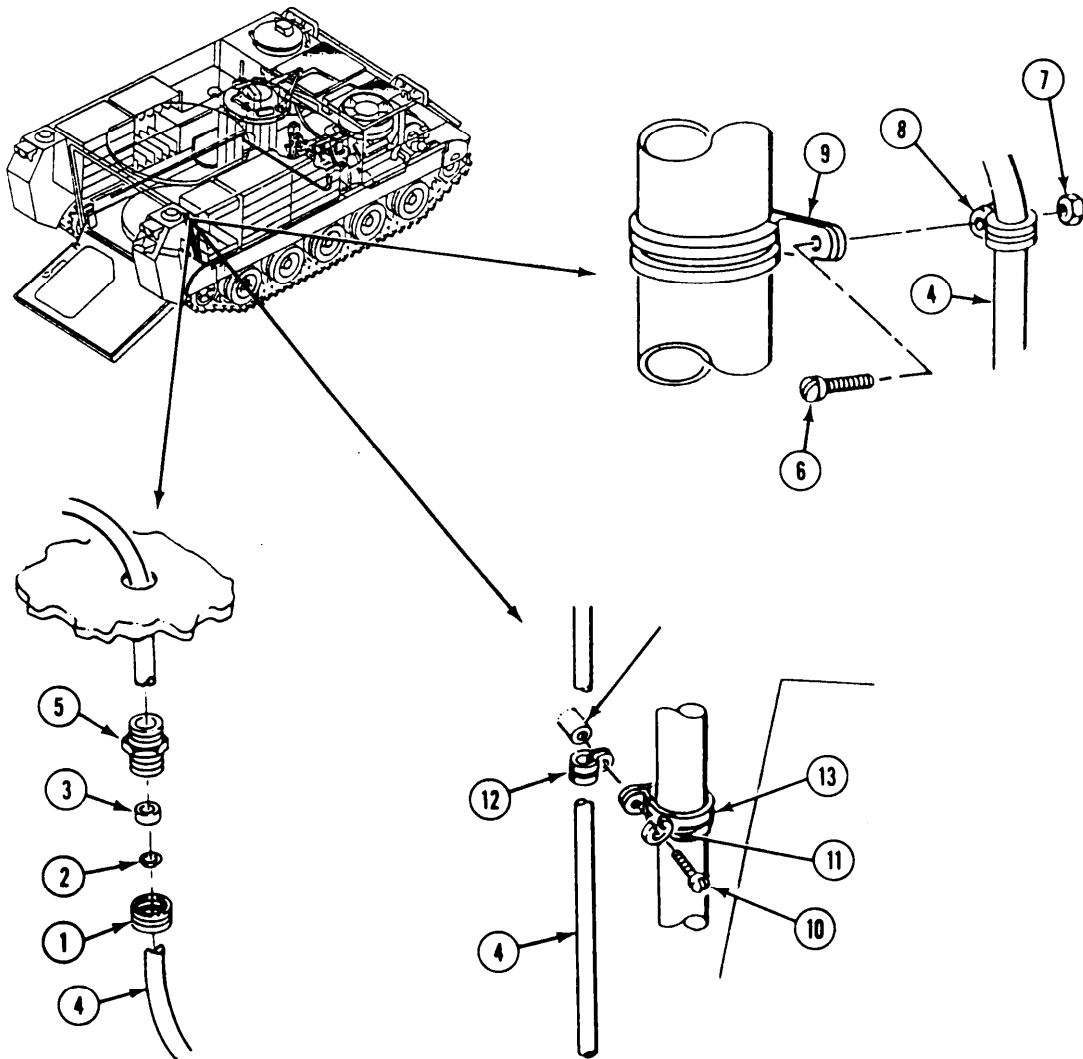

NOTE
Tag leads before removal.

12. Disconnect circuit 451 lead (1) from rear bilge pump (2).
13. Disconnect circuit 21, 22, 23, and 24 leads (3, 4, 5, and 6) from trailer wiring harness leads (7, 8, 9, and 10).
14. Remove two screws (11), locknuts (12), and clamp (13) from floor beam (14). Discard locknuts.
15. Remove screw (15), locknut (16), and clamp (13) from harness (17). Discard locknut.
16. Remove three clips (18) and harness (17) from three cradles (19).

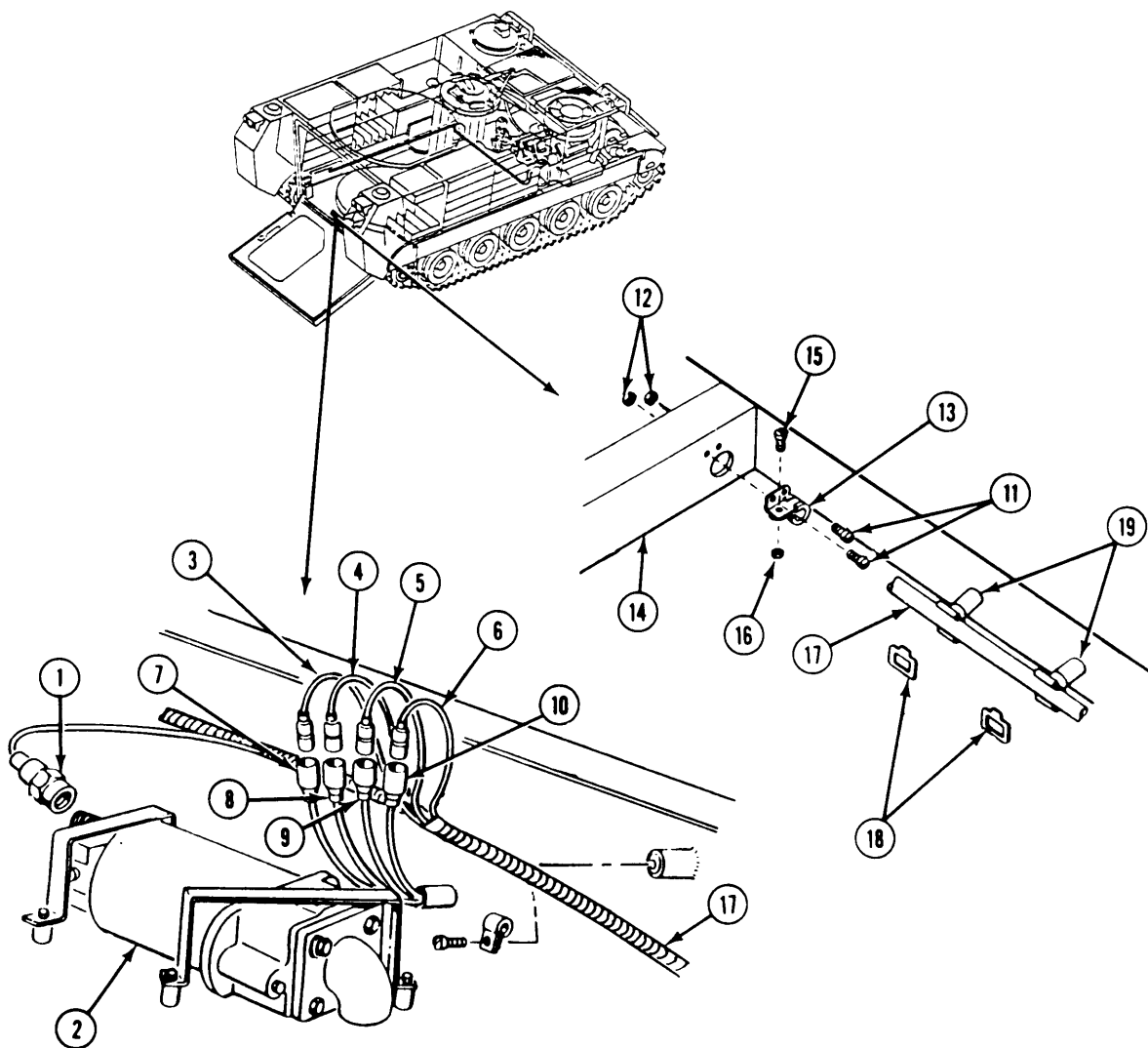

GO TO NEXT PAGE

17. Remove screw (1), lockwasher (2), clamp (3), and harness (4) from rear hull plate. Discard lockwasher.
18. Remove two screws (5), lockwashers (6), and guard (7) from two weldnuts (8) on rear hull plate. Discard lockwashers.
19. Remove two screws (9), locknuts (10), clamps (11), and harness (4) from guard (7). Discard locknuts.

20. Remove two screws (12), lockwashers (13), washers (14), and harness guard (15) from top of left fuel tank (16). Discard lockwashers.
21. Disconnect circuit 21, 22, and 24 leads (17, 18, and 19) from left tail light leads (20, 21, and 22).
22. Disconnect circuit 30 lead (23) from fuel transmitter lead (24) on left fuel tank (16).

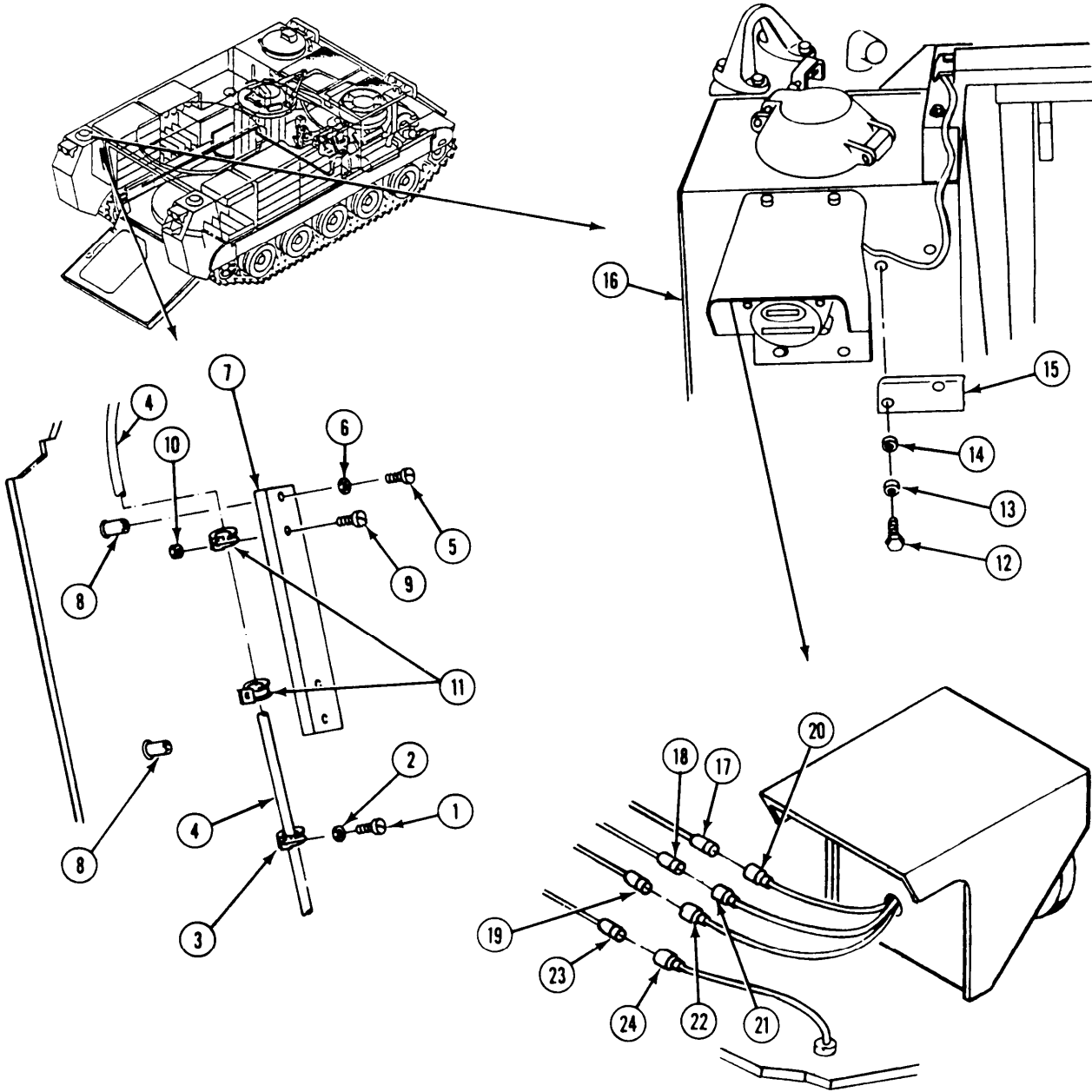

23. Remove two screws (1), lockwashers (2), washers (3), and harness bracket (4) from top of left fuel tank (5). Discard lockwashers.
24. Remove screw (6), lockwasher (7), washer (8), and harness guard (9) from top of rear hull. Discard lockwasher.
25. Pull harness (10) through hole in rear plate (11).
26. Remove nut (12), washer (13), and rubber bushing (14) around harness (10) from connector (15).
27. Remove connector (15) from hull.
28. Pull harness (10) through hole in hull top. Leave connector (15), rubber bushing (14), washer (13), and nut (12) on harness.

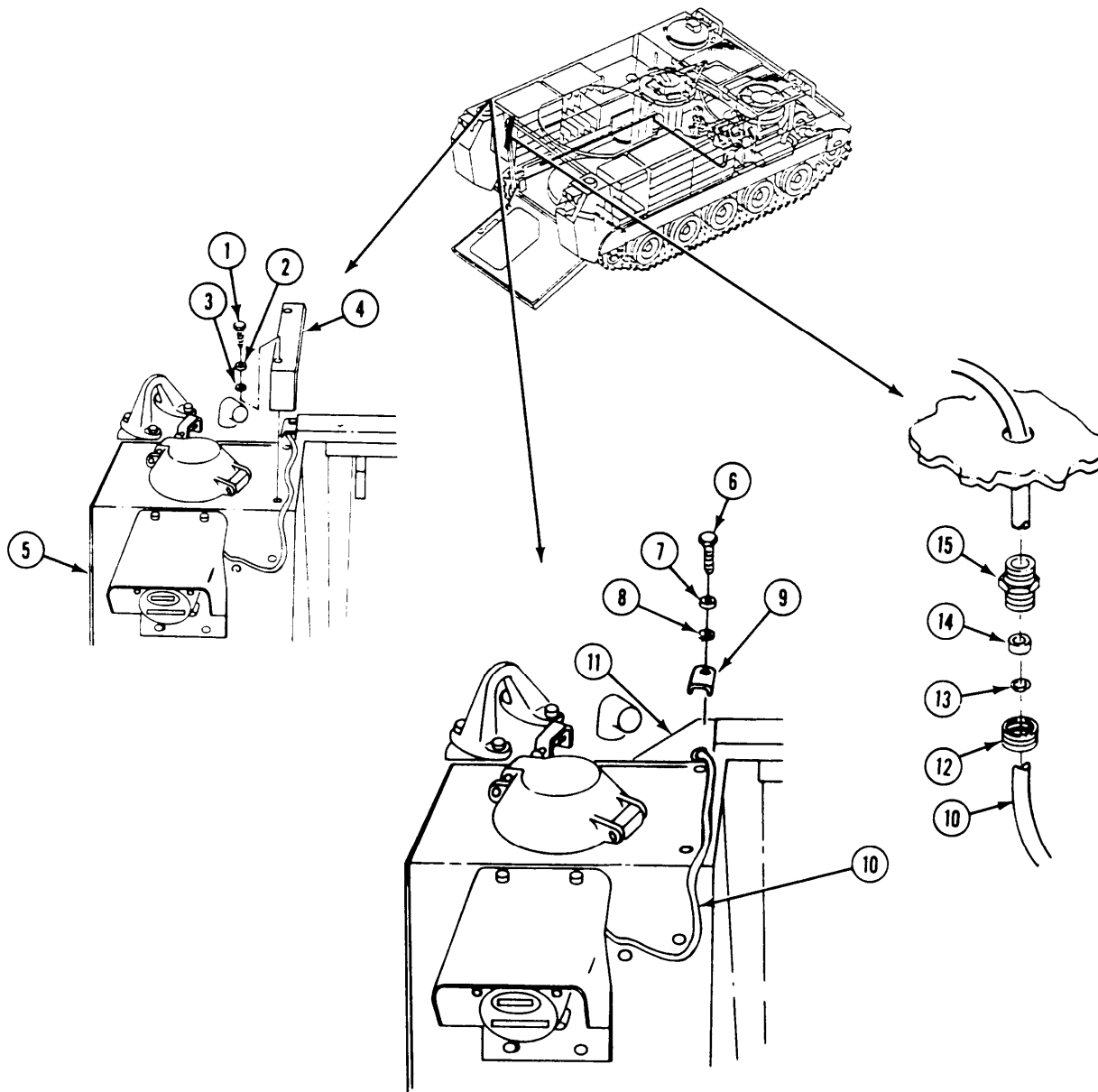

GO TO NEXT PAGE

29. Open top ammo rack (see your -10).
30. Remove 11 screws (1), lockwashers (2), clamps (3), and harness (4) from weldnuts (5) on left hull plate. Discard lockwashers.
31. Remove clip (6) and harness (4) from cradle (7).
32. Remove screw (8), cradle (7), wound lead (9), two lockwashers (10), and capacitor (11) from weldnut (12). Discard lockwashers.
33. Remove tape, screw (13), and circuit 48 lead (14) from capacitor (11).
34. Remove four screws (15), locknuts (16), and circuit 48 radio receptacle (17) from bracket (18). Discard locknuts.

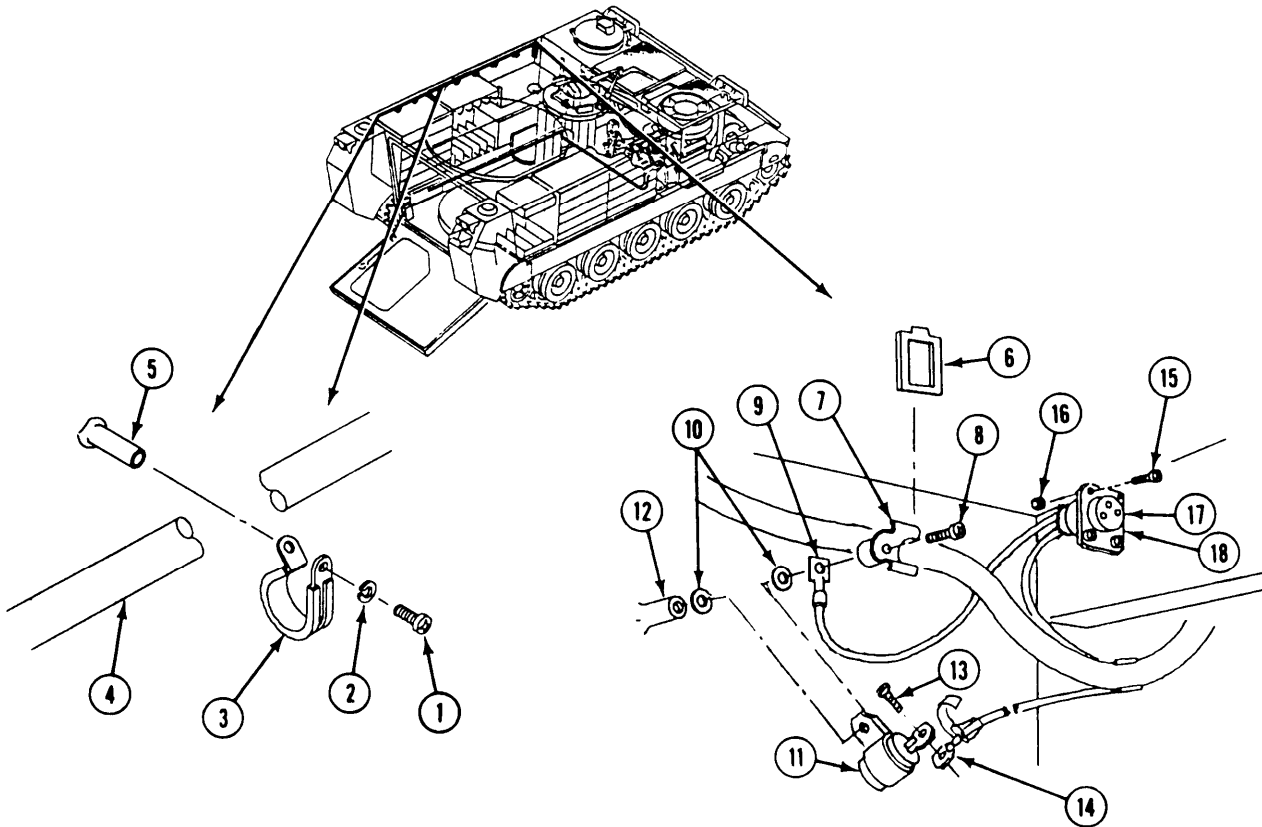

35. Remove two clips (1) and circuit 48 lead (2) from cradle (3).
36. Lower left crew seat backrest. Turn handle (4) clockwise and pull battery drawer (5) out.
37. Remove nut (6), screw (7), and circuit 6 and 48 leads (8 and 2) from battery terminal (9).
38. Remove circuit 48 lead (2) from grommet (10) in battery box (11). Discard grommet.

39. Remove two clips (12) and harness (13) from cradles (14).
40. Disconnect circuit 38 lead (15) from dome light (16).

NOTE

If needed, remove personnel heater for access.

41. Remove three screws (17), lockwashers (18), clamps (19), and circuit 38 lead (15) from three weldnuts (20). Discard lockwashers.
42. Attach twine (21) to circuit 38 lead (15). Pull lead through transverse beam (22) into driver's compartment. Remove twine from lead and leave it in transverse beam.

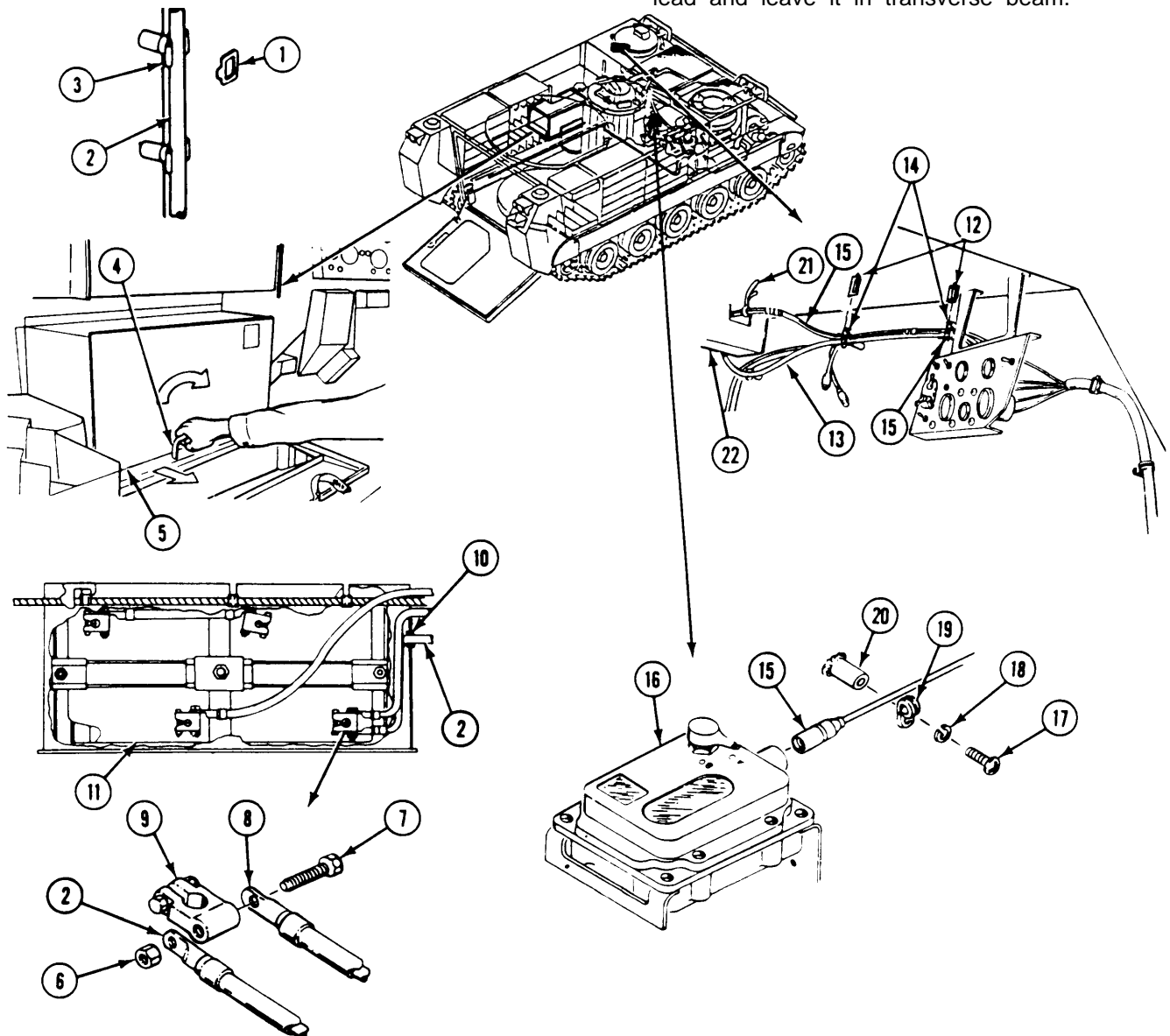

GO TO NEXT PAGE

43. If personnel heater is installed, disconnect circuit 400 lead (1) from heater control box lead.
44. If engine coolant heater is installed, disconnect circuit 400A lead (2) from engine coolant heater control box lead.
45. Remove clip (3) and harness (4) from cradle (5).
46. Remove two locknuts (6), mounts (7 and 8), washers (9), and screws (10) that secure instrument panel (11) to two struts (12). Discard locknuts.
47. Support panel (11). Remove two screws (13), internal tooth lockwashers (14), and ground lead (15) from two panel mounts (16) and bracket (17). Discard lockwashers.
48. Lower panel (11) and support on two struts (12) to gain access to rear of instrument panel.

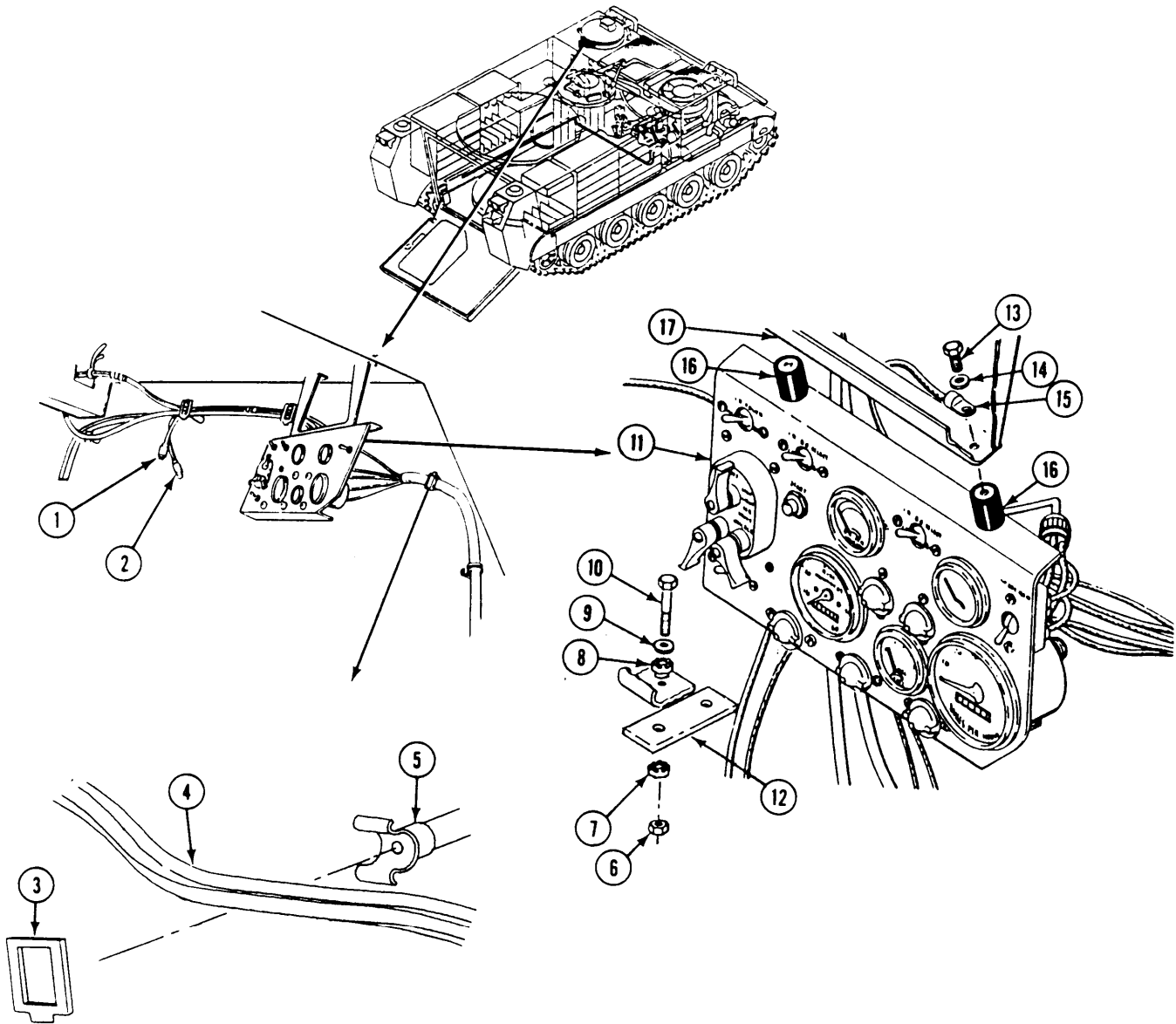

NOTE
Tag leads before removal.

- 49. Disconnect circuit 30 and 31 leads (1 and 2) from fuel gage switch (3).
- 50. Disconnect circuit 451B lead (4) from REAR BILGE PUMP ON indicator light (5).
- 51. Disconnect circuit 38 lead (6) from instrument panel wiring harness (7).
- 52. Disconnect circuit 450, 450B, and 451A leads (8, 9, and 10) from BILGE PUMPS switch leads (11, 12, and 13).
- 53. Disconnect circuit 21, 22, 23, and 24 leads (14, 15, 16, and 17) from front main wiring harness (18).

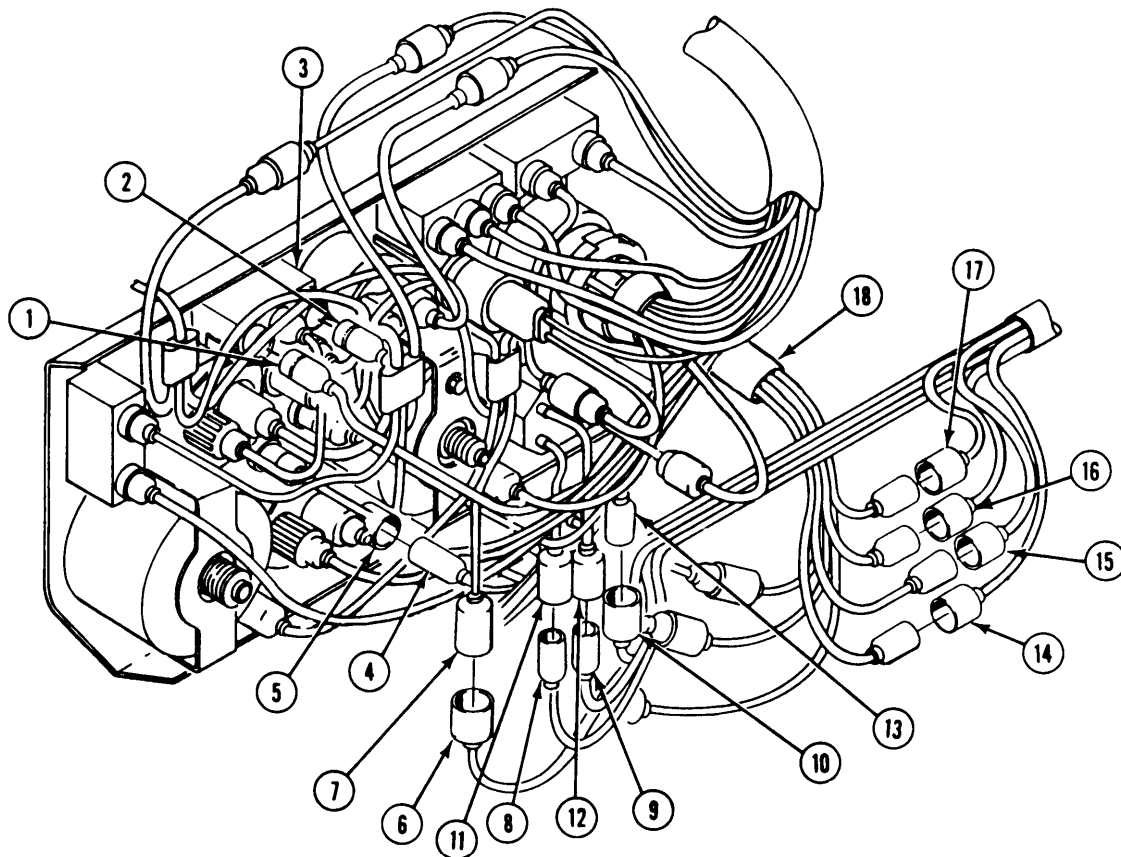

NOTE

The 200 amp and 100 amp distribution boxes are similar. Removal of most lead wires is the same. 200 amp shown.

Do step 54 for 200 amp only.

54. Disconnect circuit 37 lead (1) from master switch panel lead (2).
55. Remove eight screws (3), washers (4), and locknuts (5) from master switch panel (6). Separate panel (6) from distribution box (7). Discard locknuts.
57. Remove circuit 400 lead (10) and grommet (15) from distribution box (7). Discard grommet.
58. Disconnect circuit 450 lead (16) from lower circuit breaker (17).
59. Disconnect circuit 450B lead (18) from upper circuit breaker (19).
60. Remove circuit 450 and 450B leads (16 and 18) and two grommets (20) from distribution box (7).
61. Remove harness from earner.

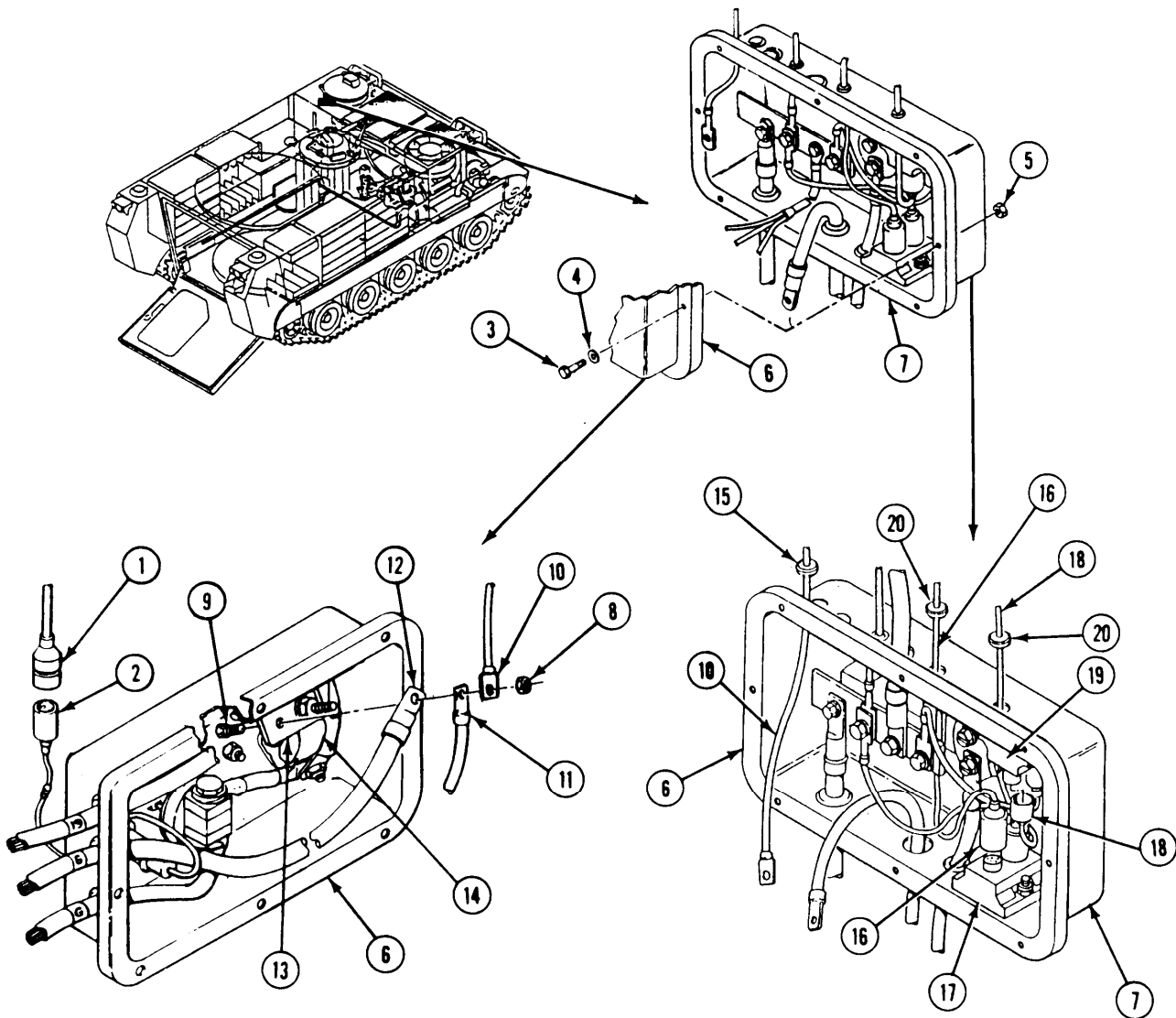

CLEAN, INSPECT, AND REPAIR

- 62. Check harness for continuity. Use multimeter.
- 63. Repair harness (page 14-3).

- 68. Install circuit 400 lead (7) and new grommet (8) in distribution box (4).
- 69. Install circuit 6, 2, and 400 leads (9, 10, and 7) on bus bar (11) on MASTER SWITCH (12). Secure with screw (13) and new locknut (14).

INSTALL

- 64. Install harness in carrier.
- 65. Install circuit 450 and 450B leads (1 and 2) and two new grommets (3) in distribution box (4).
- 66. Connect circuit 450B lead (2) to upper circuit breaker (5).
- 67. Connect circuit 450 lead (1) to lower circuit breaker (6).

NOTE
Inspect gasket on distribution box.
Replace if damaged.

- 70. Install master switch panel (15) on distribution box (4). Secure with eight screws (16), washers (17), and new locknuts (18).
- 71. Connect circuit 37 lead (19) to master switch panel lead (20).

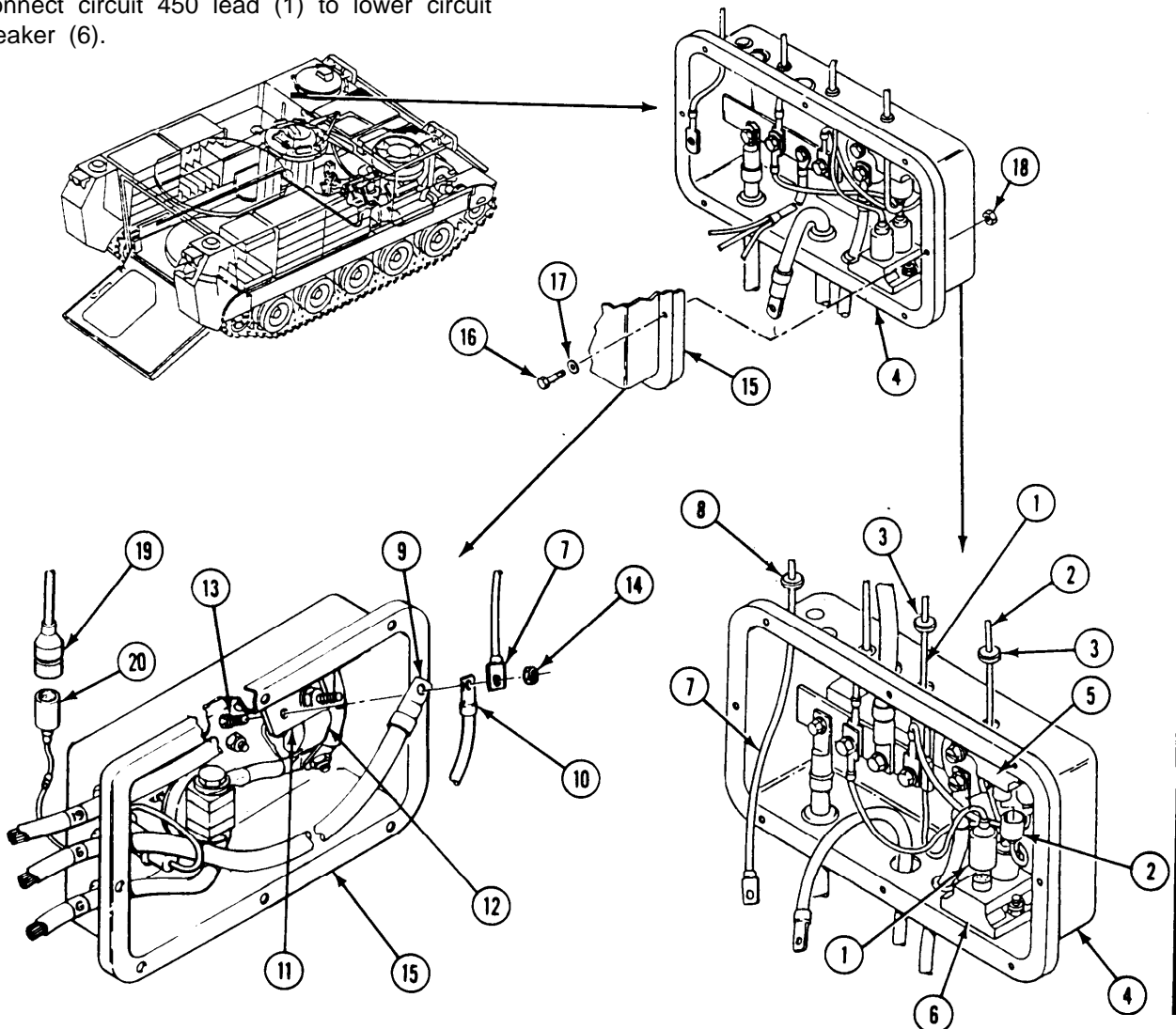

GO TO NEXT PAGE

- '2. Connect circuit 21, 22, 23, and 24 leads (1, 2, 3, and 4) to front main wiring harness (5).
- '3. Connect circuit 450, 450B, and 451A leads (6, 7, and 8) to BILGE PUMPS switch leads (9, 10, and 11).
- 74. Connect circuit 38 lead (12) to instrument panel wiring harness (13).

- 75. Connect circuit 451B lead (14) to REAR BILGE PUMP ON indicator light (15).
- 76. Connect circuit 30 and 31 leads (16 and 17) to fuel gage switch (18).

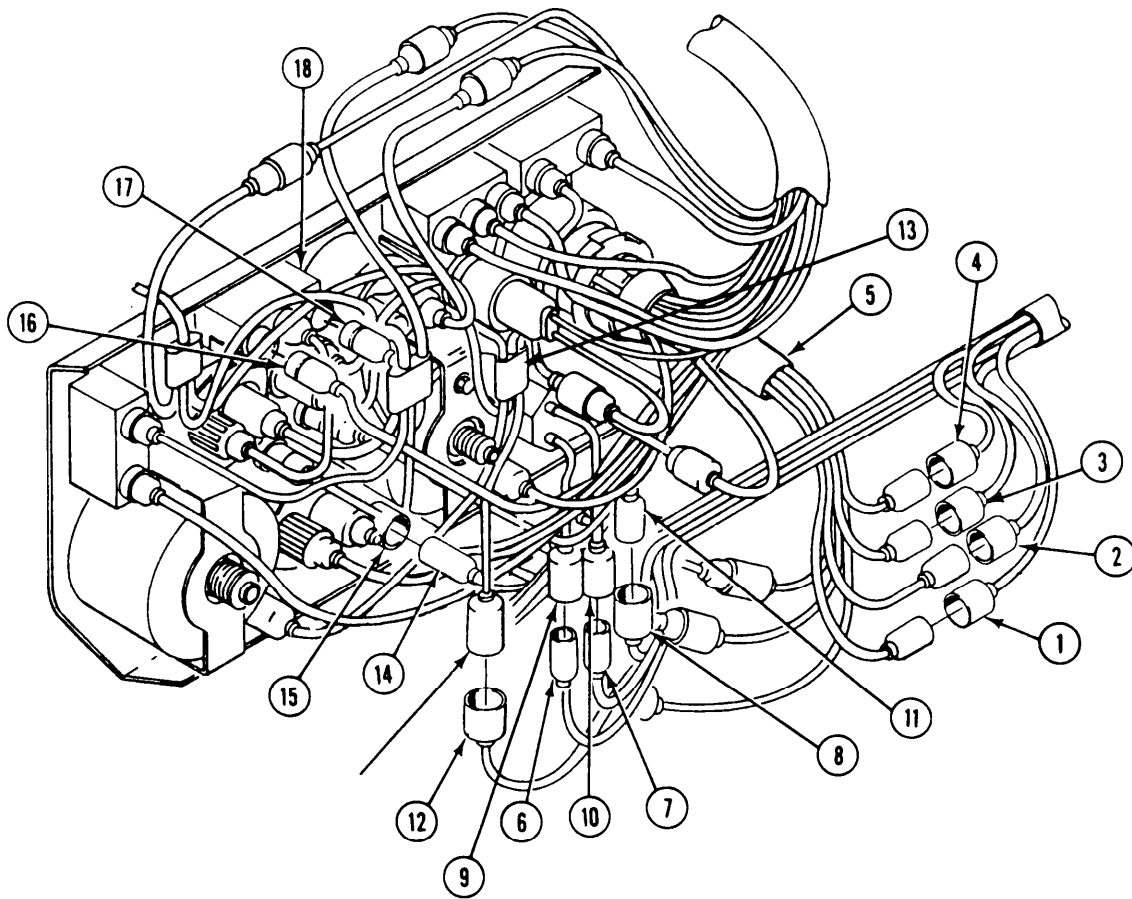

- 77. Position ground lead (1) at forward hole of bracket (2). Secure instrument panel (3) to bracket with two panel mounts (4), screws (5) and new internal tooth lockwasher (6).
- 78. Secure panel (3) to two struts (7) with two mounts (8 and 9), screws (10), washers (11), and new locknuts (12).
- 79. Secure harness (13) to cradle (14) with clip (15).
- 80. If engine coolant heater is installed, connect circuit 400A lead (16) to engine coolant heater control box lead.
- 81. If personnel heater is installed, connect circuit 400 lead (17) to heater control box lead.

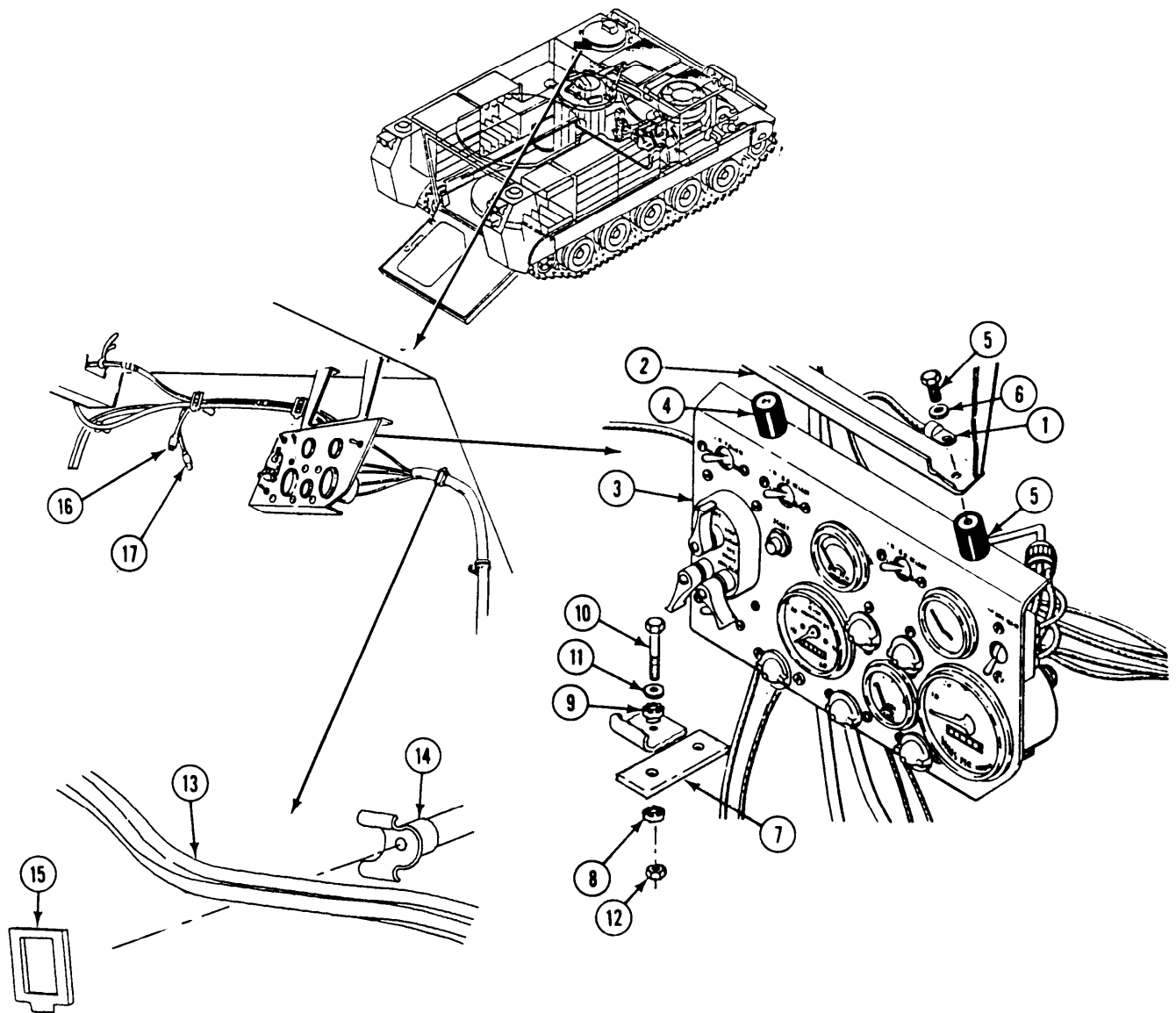

GO TO NEXT PAGE

82. Attach twine (1) that was left in transverse beam (2) to circuit 38 lead (3). Pull lead through transverse beam (2) into personnel compartment. Remove twine from lead.
83. Secure circuit 38 lead (3) to three weldnuts (4) on transverse beam with three clamps (5), screws (6), and new lockwashers (7).
84. Connect circuit 38 lead (3) to dome light (8).
85. Install harness (9) in two cradles (10) and secure with clips (11).
86. Install circuit 48 lead (12) and new grommet (13) in battery box (14).
87. Install circuit 6 and 48 leads (15 and 12) on battery terminal (16). Secure with screw (17) and nut (18).
88. Push battery drawer (19) in and turn handle (20) counterclockwise to lock drawer. Raise left crew seat backrest.
89. Install circuit 48 lead (12) in cradle (21) and secure with clip (22).

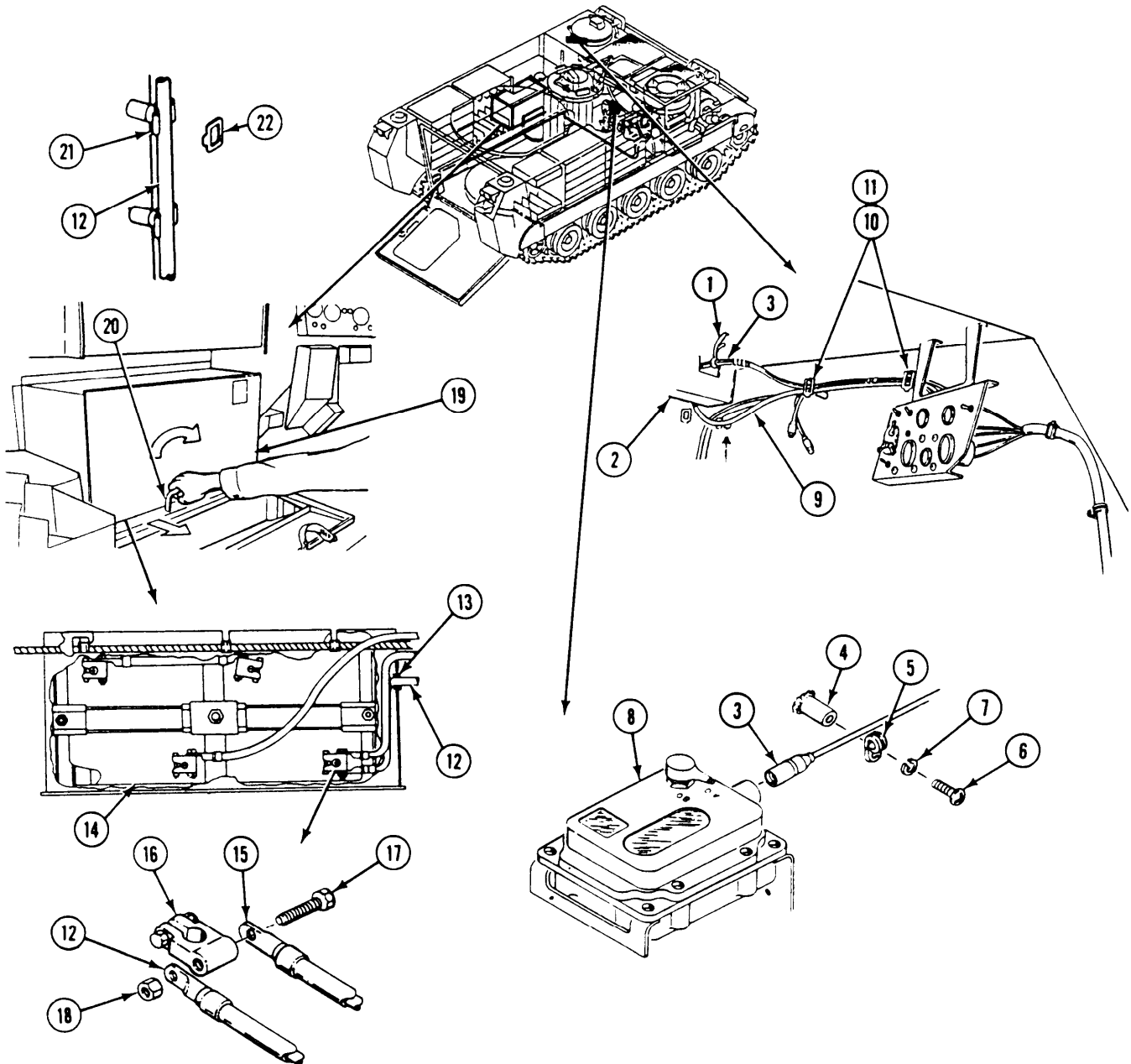

- 90. Install circuit 48 radio receptacle (1) on bracket (2). Secure with four screws (3) and new locknuts (4).
- 91. Connect circuit 48 lead (5) to capacitor (6). Secure with screw (7) and tape.
- 92. Install capacitor (6), ground lead (8), and cradle (9) on weldnut (10) with two new lockwashers (11) and screw (12).

- 93. Install harness (13) in cradle (9) and secure with clip (14).
- 94. Secure harness (13) to weldnuts (15) on left hull plate with 11 clamps (16), screws (17), and new lockwashers (18).
- 95. Close top ammo rack (see your -10).

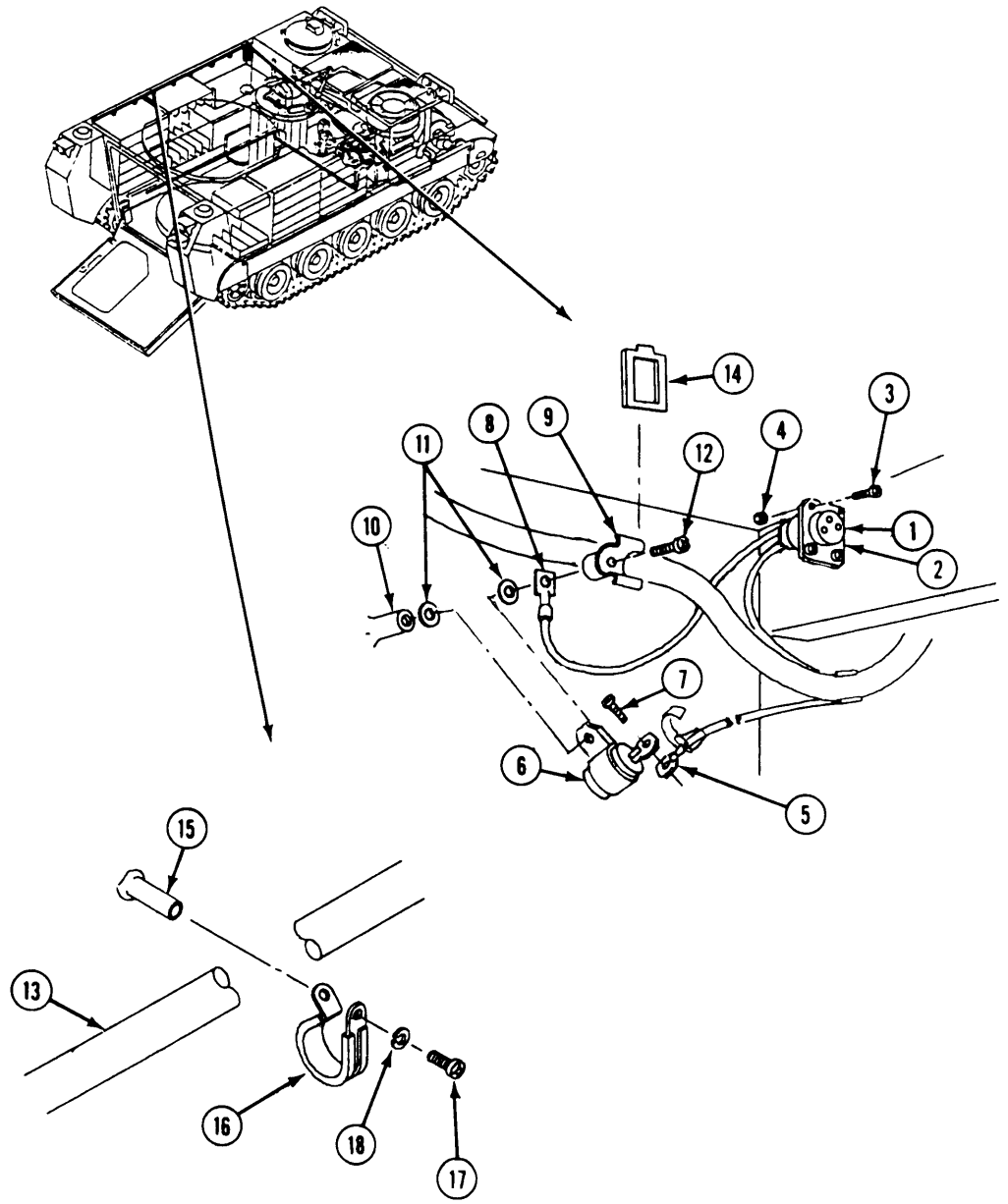

GO TO NEXT PAGE

96. Insert harness left side branch (1) through hole in hull top.
97. Install connector (2) in hull.
98. Secure harness (1) in connector (2) with rubber bushing (3), washer (4), and nut (5).
99. Insert harness (1) through hole in rear plate (6).

100. Install harness guard (7) on top of rear hull. Secure with screw (8), washer (9), and new lockwasher (10).
101. Route harness (1) along top of left fuel tank (11) and install harness bracket (12) over harness (1). Secure with two screws (13), washers (14), and new lockwashers (15).

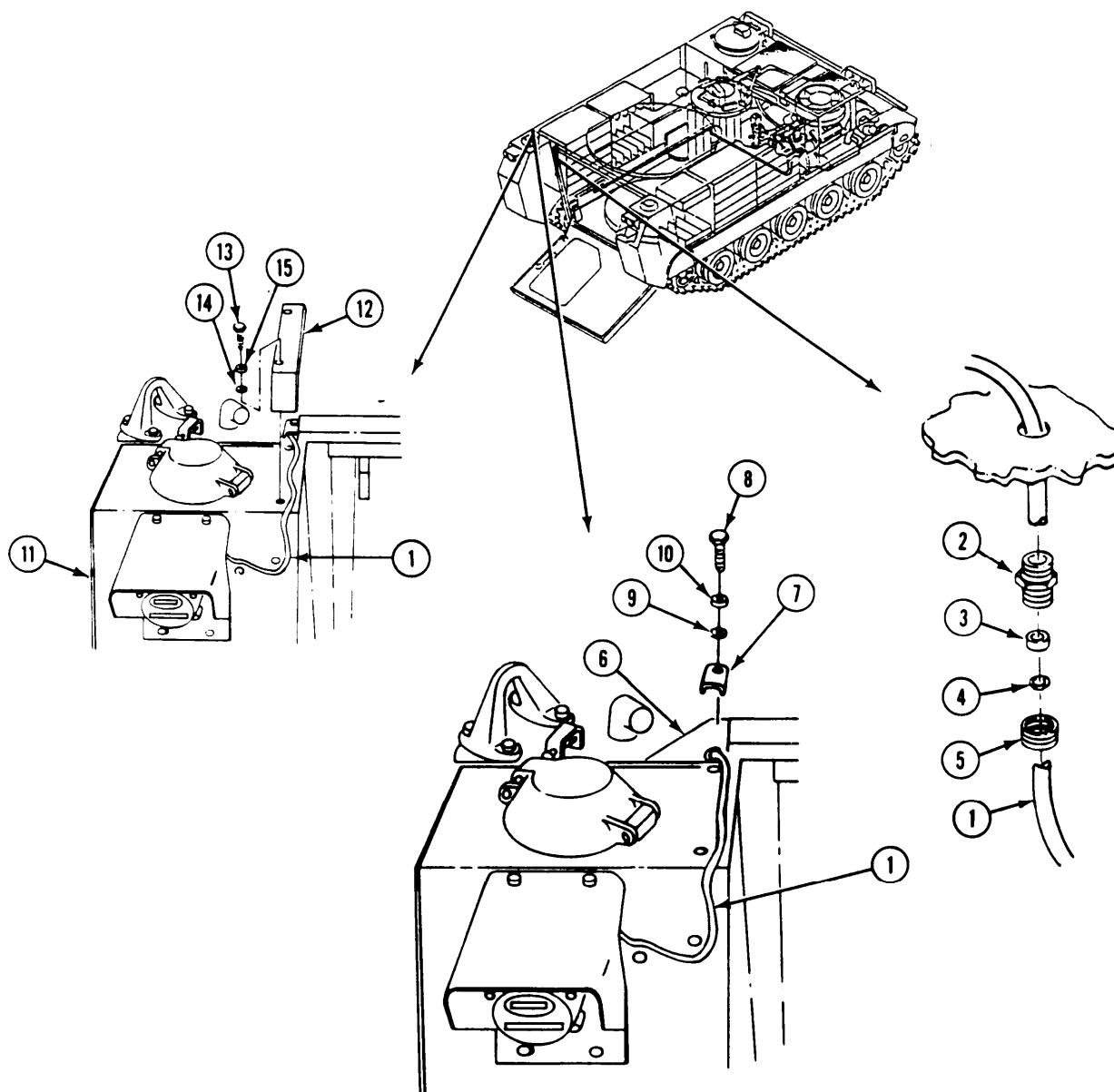

- 102. Connect circuit 30 lead (1) to fuel transmitter lead (z) on left fuel tank (3).
- 103. Connect circuit 21, 22, and 24 leads (4, 5, and 6) to left tail light leads (7, 8, and 9).
- 104. Install harness guard (10) over harness (11) on left fuel tank (3). Secure with two screws (12), washers (13), and new lockwashers (14).
- 105. Secure harness (11) to guard (15) with two clamps (16), screws (17), and new locknuts (18).
- 106. Install guard (15) on two weldnuts (19) on rear hull plate. Secure with two screws (20) and new lockwashers (21).
- 107. Secure harness (11) on rear hull plate with clamp (22), screw (23), and new lockwasher (24).

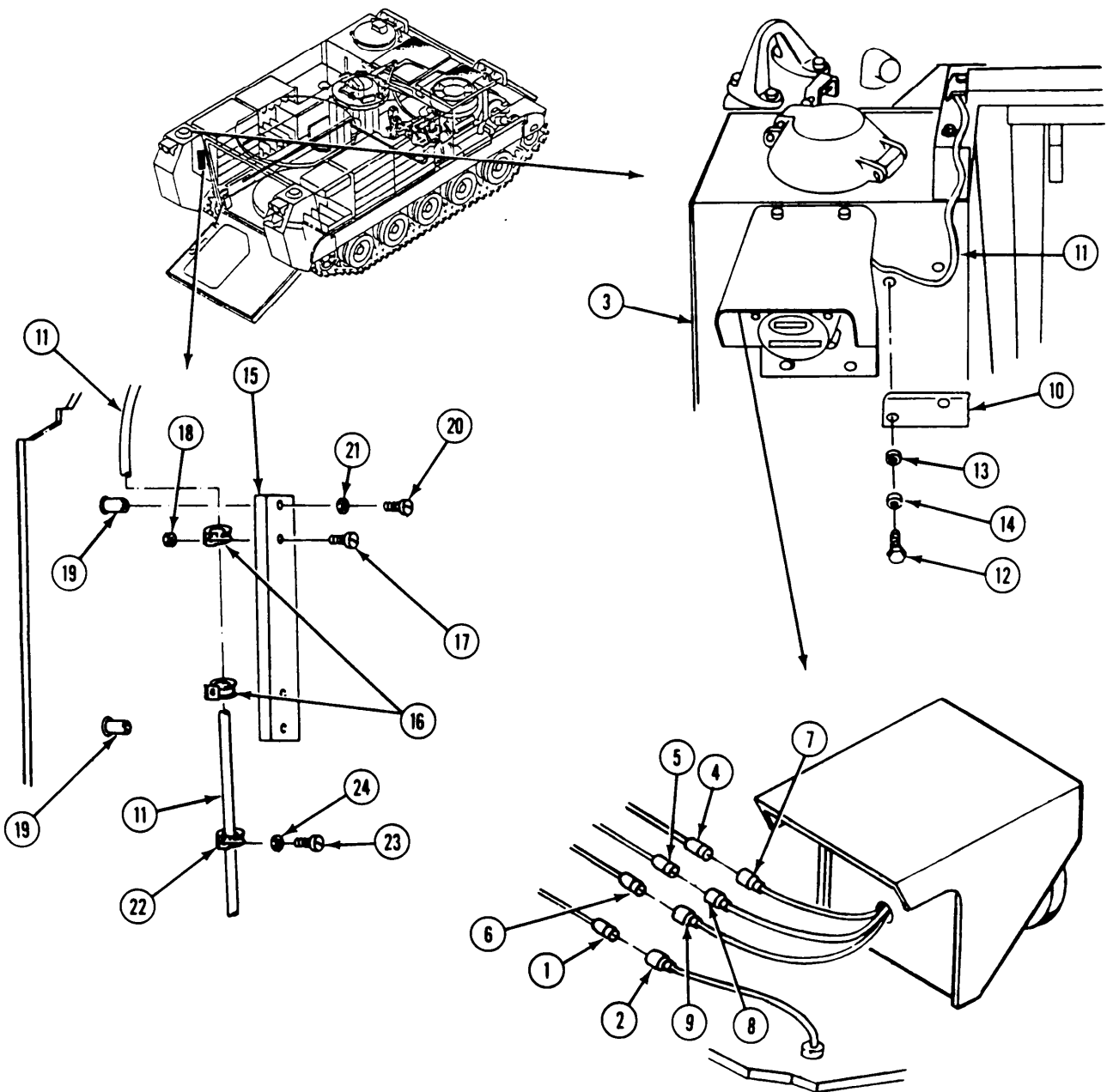

GO TO NEXT PAGE

- 108. Install harness (1) in three cradles (2) and secure with three clips (3).
- 109. Install clamp (4) on harness (1) with screw (5) and new locknut (6).
- 110. Secure clamp (4) to floor beam (7) with two screws (8) and new locknuts (9).

- 111. Connect circuit 21, 22, 23, and 24 leads (10, 11, 12, and 13) to trailer wiring harness leads (14, 15, 16, and 17).
- 112. Connect circuit 451 lead (18) to rear bilge pump (19).

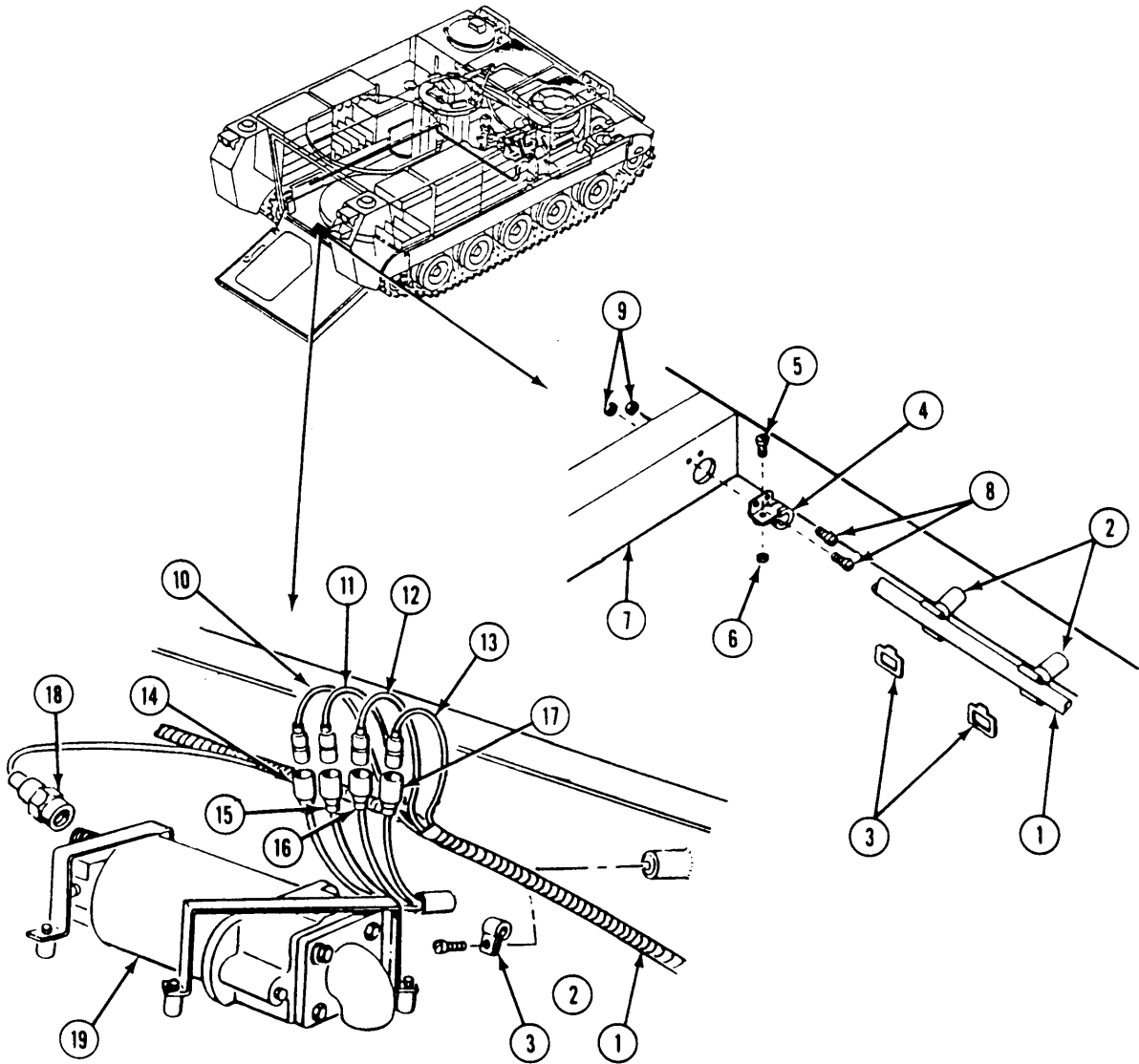

- 113. Secure harness (1) to two lower bilge tube clamps (2) with two clamps (3), screws (4), and new lockwashers (5).
- 114. Secure harness (1) to upper bilge tube clamp (6) with clamp (7), screw (8), and new locknut (9).

- 115. Insert harness right side branch (1) through hole in hull top.
- 116. Install connector (10) in hull.
- 117. Secure harness (1) in connector (10) with rubber bushing (11), washer (12), and nut (13).

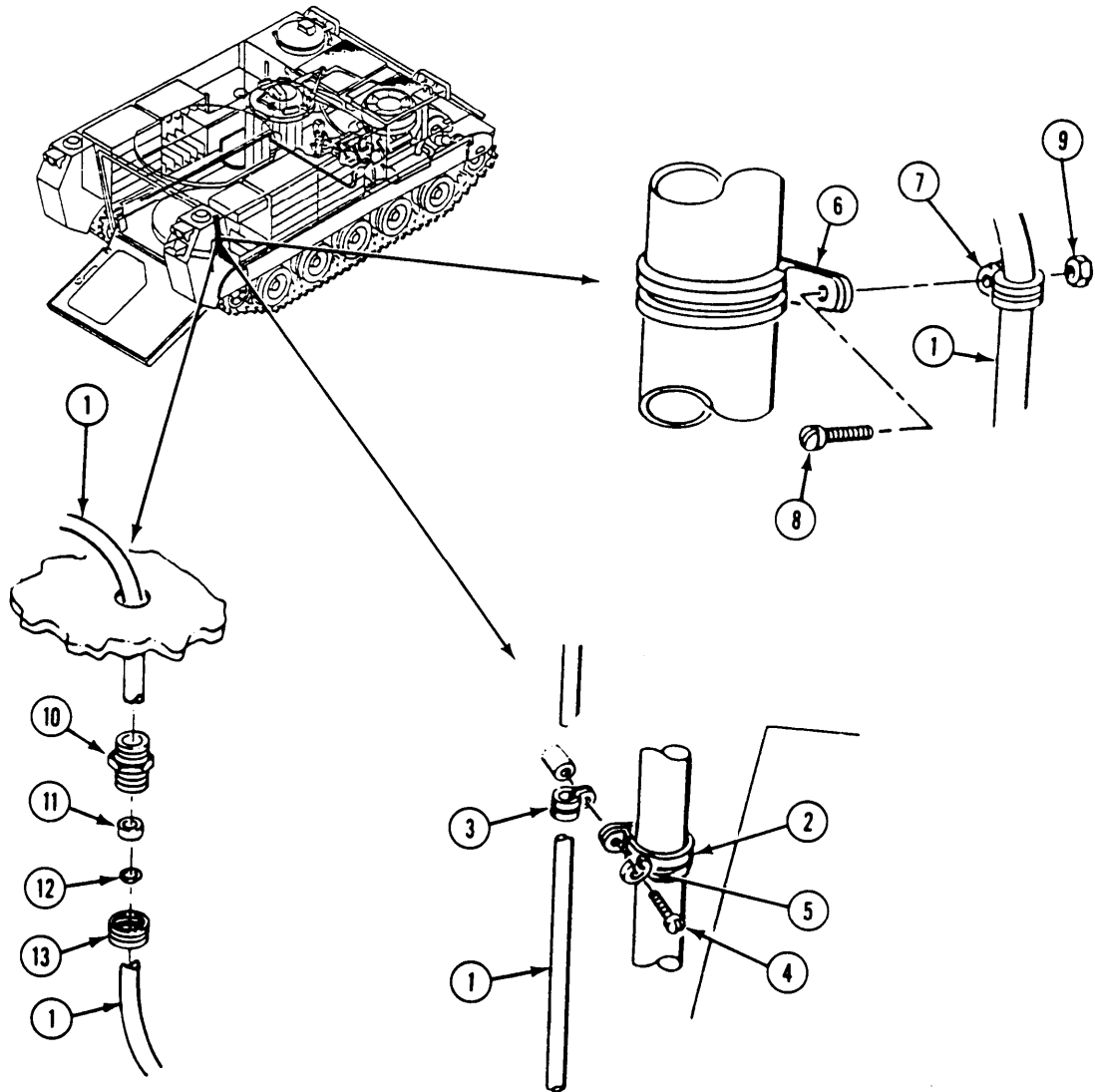

GO TO NEXT PAGE

118. Insert harness (1) through hole in rear plate (2).
119. Install harness guard (3) on top of rear hull. Secure with screw (4), washer (5), and new lockwasher (6).
118. Route harness (1) along top of right fuel tank (7) and install harness bracket (8) over harness (1). Secure with two screws (9), washers (10), and new lockwashers (11).
121. Connect circuit 31 lead (12) to fuel transmitter lead (13) On right fuel tank (7).
122. Connect circuit 23 and 24 leads (14 and 15) to right tail light leads (16 and 17).
123. Install harness guard (18) over harness (1) on right fuel tank (7). Secure with two screws (19), washers (20), and new lockwashers (21).

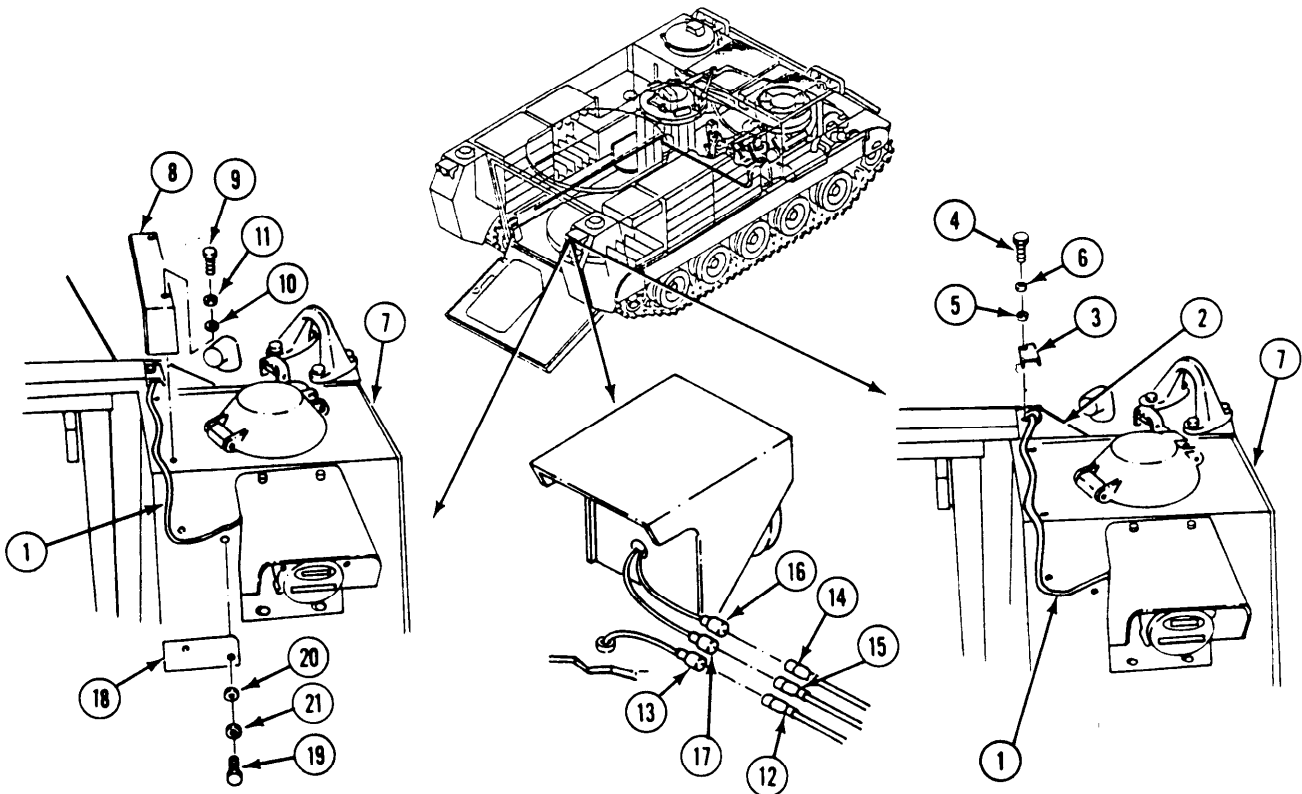

FOLLOW-THROUGH STEPS

1. Install rear floor plate (page 24-38).
2. Connect battery ground lead (page 13-2).
3. Turn MASTER SWITCH ON and start engine (see your -10).
4. Check that electrical system works properly (see your -10).
5. Raise and lock ramp (see your -10).
6. Stop engine (see your -10).

END OF TASK

REPLACE REAR MAIN WIRING HARNESS (M113A2, M901A1, AND M1059 ONLY)

DESCRIPTION

This task covers: Remove (page 12-1 19), Install (page 12-125).

INITIAL SETUP

Tools:

General Mechanics Tool Kit (Item 30, App D)

References:

See your -10

Materials/Parts:

Terminal (3)
 Gasket
 Grommet (3)
 Lockwasher, as needed
 Self-locking nut (8)

Equipment Conditions:

Engine stopped/shutdown (see your -10)
 Carrier blocked (see your -10)
 Battery ground lead disconnected (page 13-2)
 Ramp lowered (see your -10)
 Rear floor plate removed (page 24-37)

Personnel Required:

Unit Mechanic

REMOVE

1. Disconnect circuit 38 lead (1) from rear dome light (2).
2. Remove screw (3), clamp (4), nut (5), and circuit 38 lead (1) from rear dome light (2).
3. Remove three cradle clips (6) and circuit 38 lead (1) from three cradles (7).
4. Disconnect circuits 23 and 24 leads (8 and 9) from right tail light (10).
5. Remove nut (11), washer (12), clamp (13), and circuits 38, 23, and 24 leads (14, 8, and 9) from right tail light (10).
6. Remove screw (15), nut (16), clamp (17), and rear main wiring harness (18) from clamp (19).

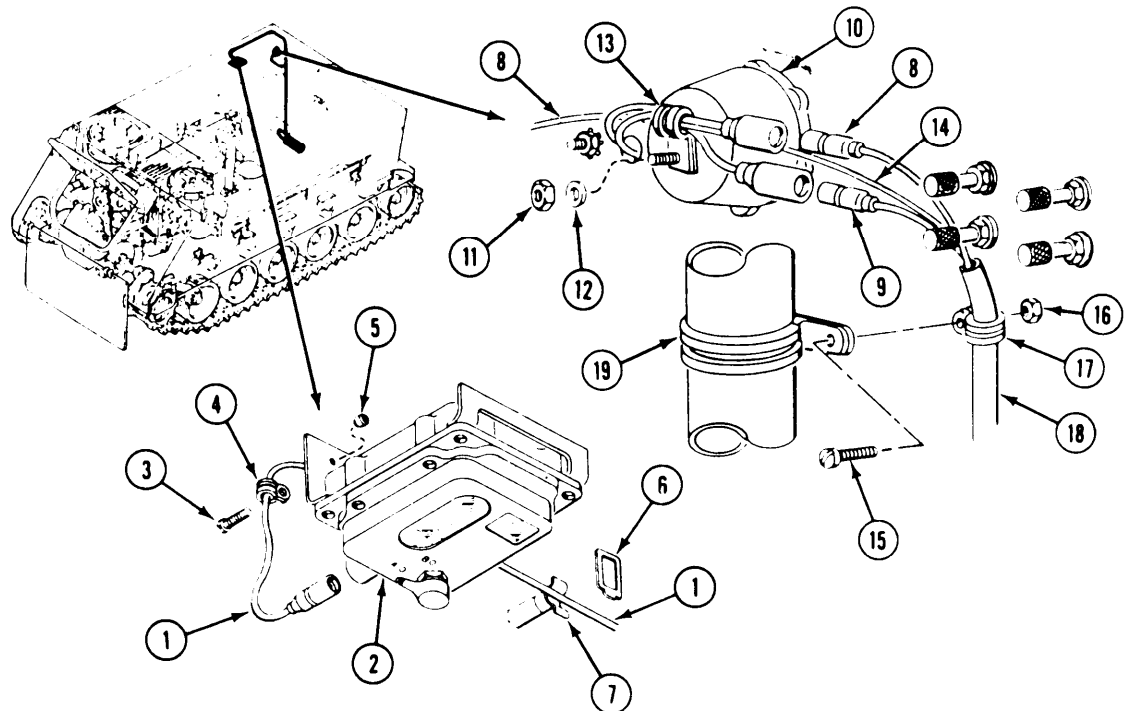

GO TO NEXT PAGE

7. Disconnect circuit 451 lead (1) from rear bilge pump (2).
8. Disconnect circuit 21, 22, 23, and 24 leads (3, 4, 5, and 6) from trailer tiring harness (7).
9. Remove two screws (8), clamps (9), washers (10), circuit 90 lead (11), and wiring harness (12) from two weldnuts (13).
10. Remove screw (14), clamp (15), bilge tube clamp (16), and wiring harness (17) from weldnut (18).
11. Remove two screws (19), nuts (20), and clamp (21) from floor transverse beam (22).
12. Remove screw (23), nut (24), and clamp (21) from circuit 451 lead (25).
13. Remove screw (26), lockwasher (27), clamp (28), and circuit 451 lead (25) from weldnut (29). Discard lockwasher.
14. Remove two cradle clips (30) and circuit 451 lead (25) from two cradles (31).
15. If personnel heater is installed, disconnect circuit 402 lead (32) from personnel heater fuel pump (33).
16. If engine coolant heater is installed, disconnect circuit 402A lead (34) from engine coolant heater fuel pump (35).

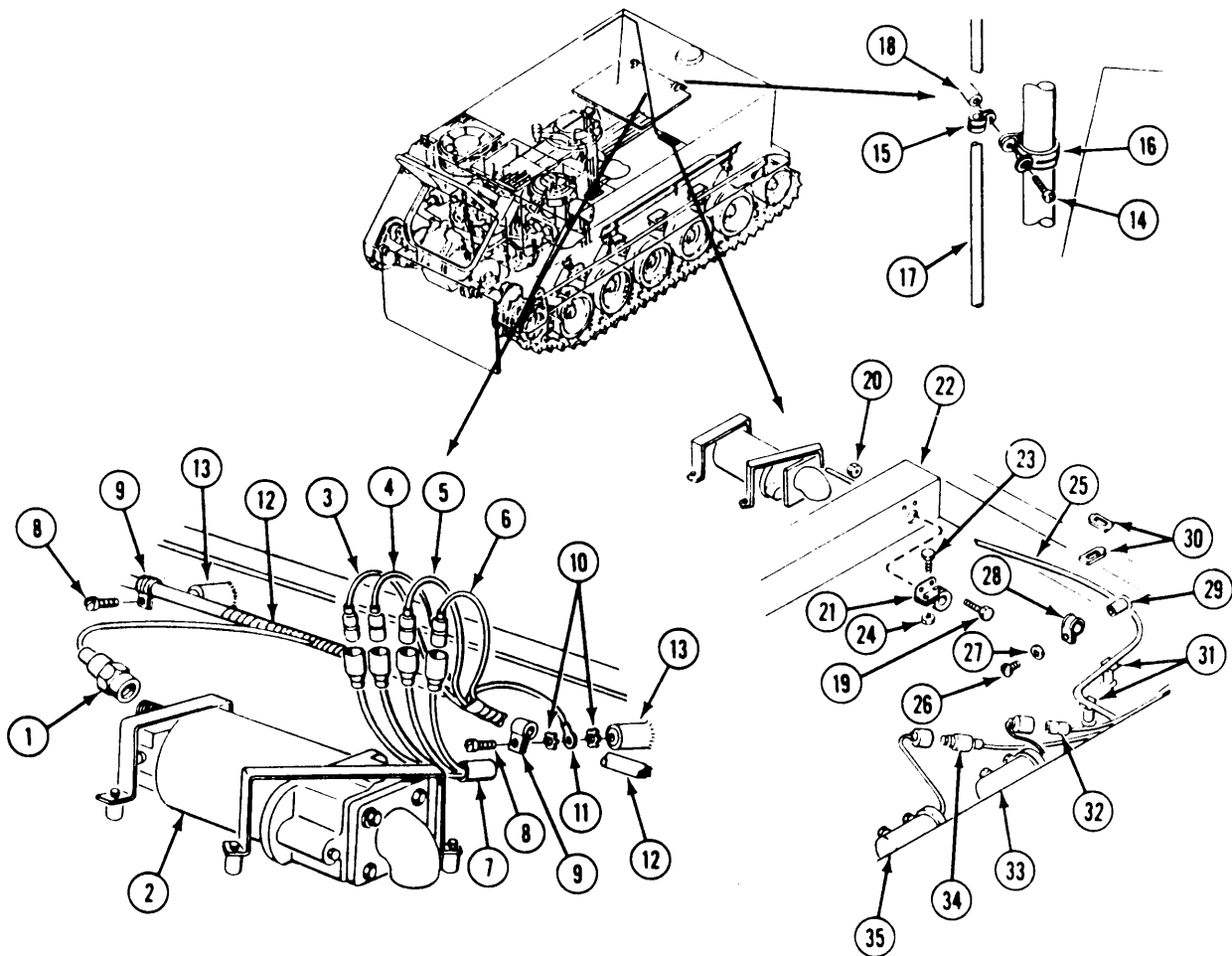

17. Remove two straps (1) and rear main wiring harness (2) from fuel tube (3).
18. Remove cradle clip (4) and harness (2) from cradle (5).
19. Remove two screws (6), lockwashers (7), guard (8), and ground strap (9) from hull. Discard lockwashers.
20. Remove two screws (10), nuts (11), clamps (12), and wiring harness (2) from guard (8).
21. Remove four screws (13), lockwashers (14), guard (15), and left tail light (16) from hull. Discard lockwashers.
22. Disconnect circuits 21, 22, and 24 leads (17, 18, and 19) from left tail light (16).
23. Remove three terminals (20), insulators (21), and connectors (22) from three leads (17, 18, and 19). Discard terminals.
24. Remove nut (23) and bushing (24) from connector (25).
25. Pull three leads (17, 18, and 19) through connector (25).

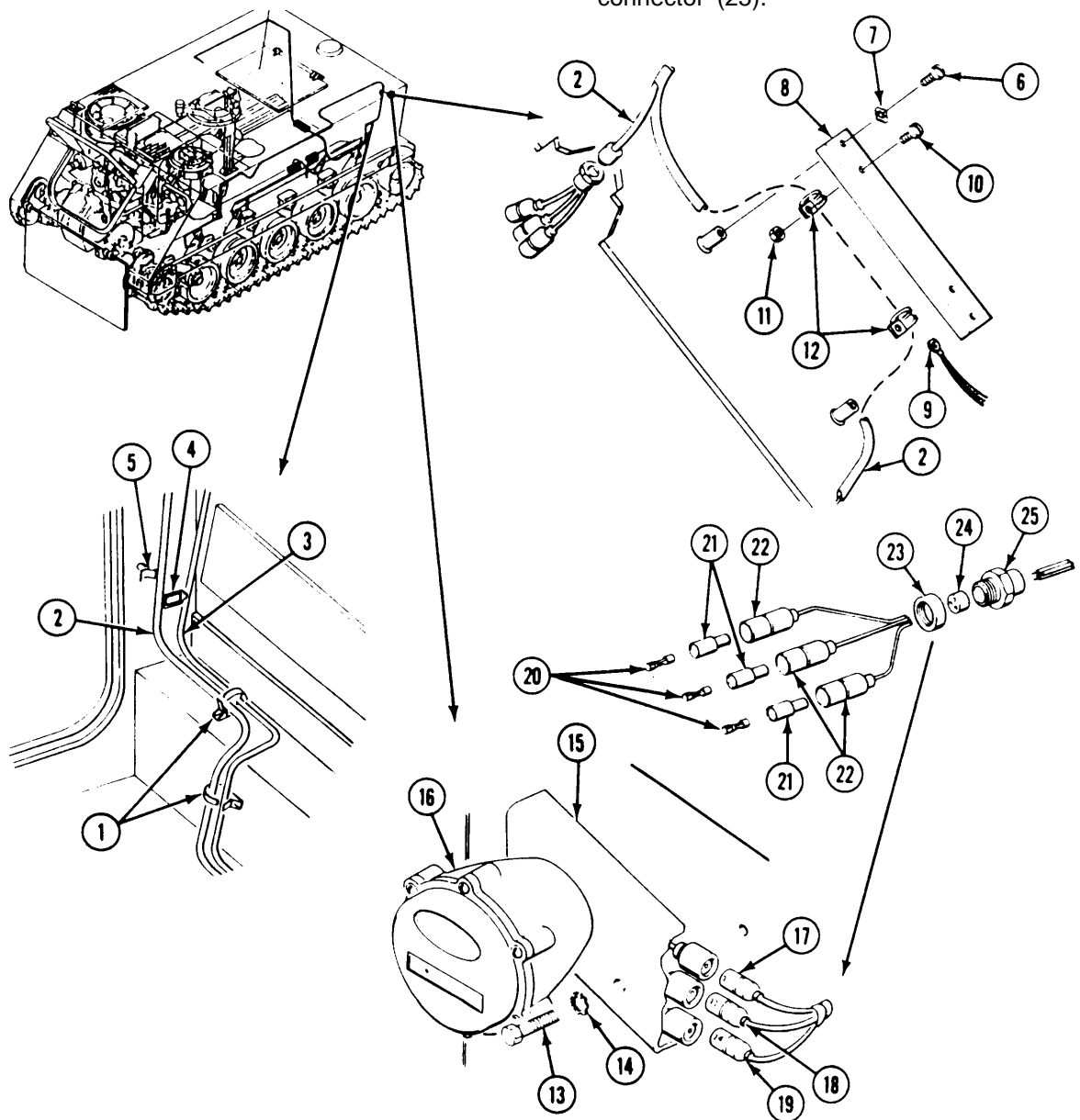

GO TO NEXT PAGE

26. Disconnect circuit 28 lead (1) from fuel quantity sending unit (2).
27. Remove screw (3) and circuit 28 lead (1) from clamp (4).
28. Remove two cradle clips (5) and rear main wiring harness (6) from two cradles (7).
29. Remove screw (8), clamp (9), and wiring harness (6) from weldnut (10).

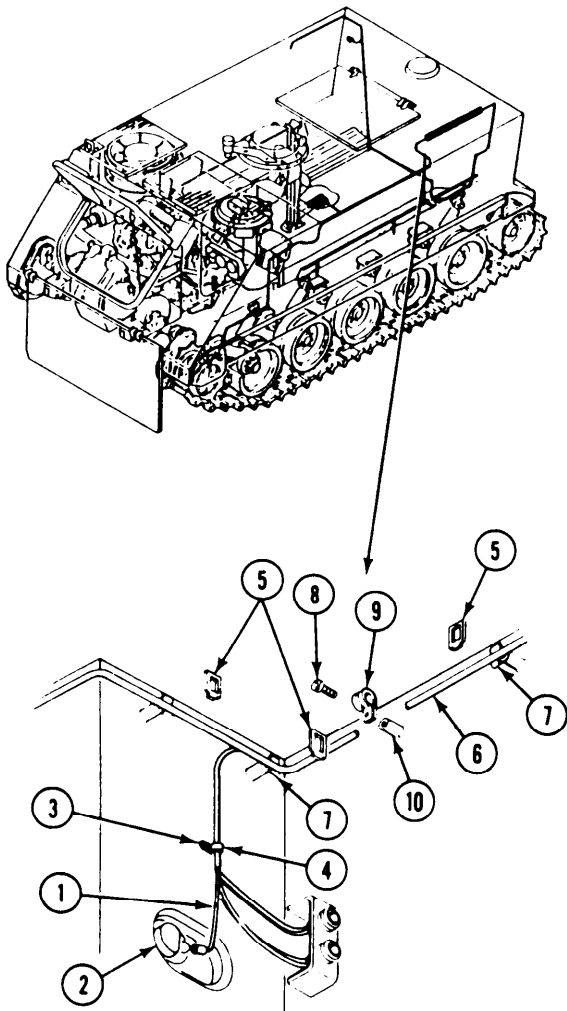

30. Disconnect circuit 38 lead (11) from front dome light (12).
31. If personnel heater is installed, disconnect circuit 402 lead (13) from personnel heater wiring harness and circuit 400 lead (14) from personnel heater control box.
32. If engine coolant heater is installed, disconnect circuit 402A lead (15) from engine coolant heater wiring harness and circuit 400A lead (16) from engine coolant heater control box.
33. Remove seven cradle clips (17) and wiring harness (6) from seven cradles (18).

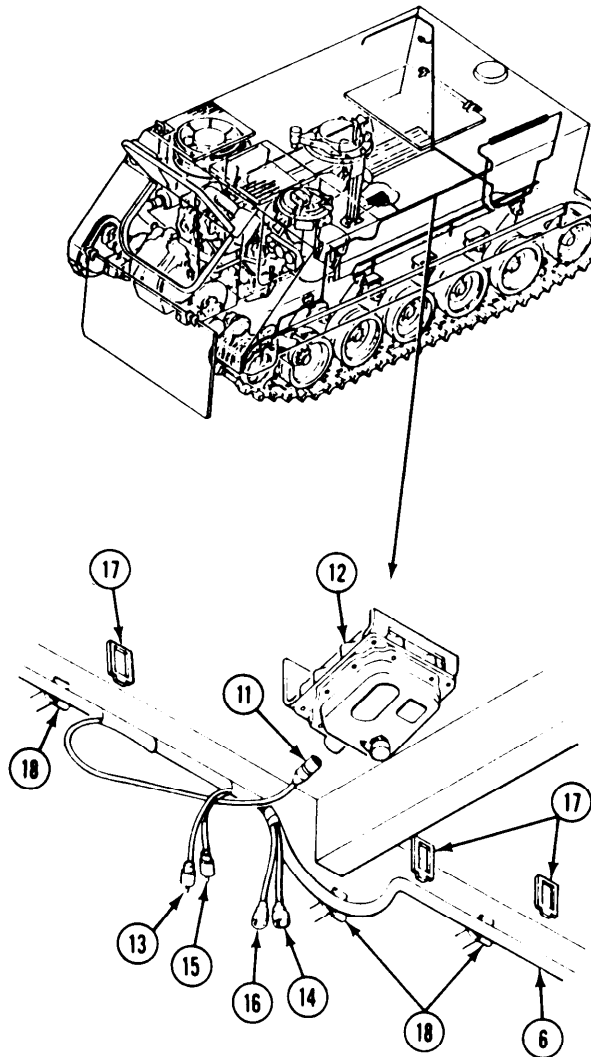

34. Remove two screws (1), lockwashers (2), and guard (3) from two weldnuts (4). Discard lockwashers.
35. Remove three screws (5), nuts (6), clamps (7), and wiring harness (8) from guard (3).

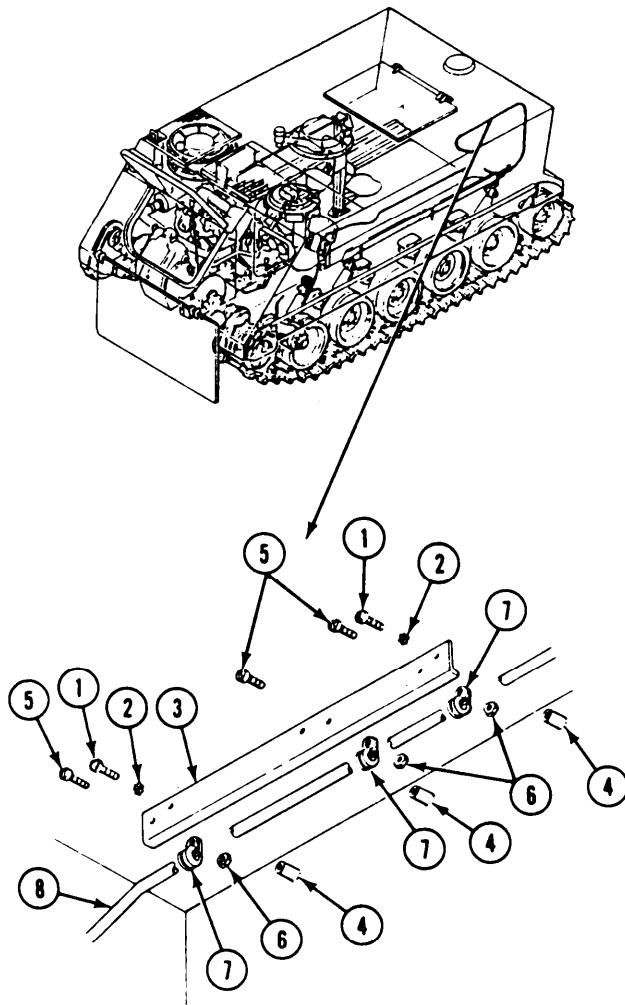

36. Remove eight screws (9), washers (10), and locknuts (11). Separate master switch panel (12) from distribution box (13). Discard locknuts.

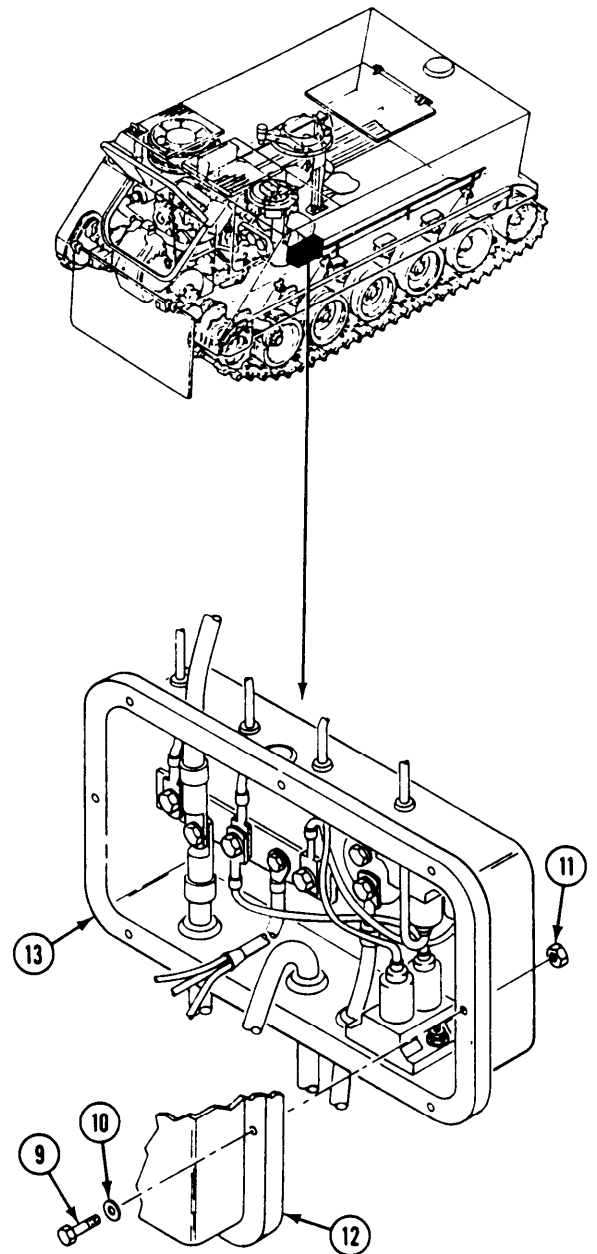

GO TO NEXT PAGE

37. Remove nut (1), lockwasher (2), screw (3), circuits 6, 2, and 400 leads (4, 5, and 6) from bus bar (7). Discard lockwasher.

38. Disconnect circuit 38 lead (8) from circuit 37 lead (9).

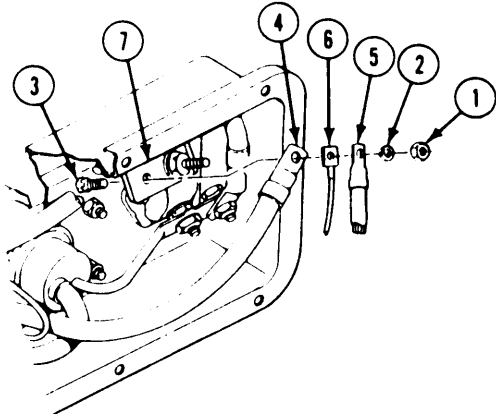

M1059 ONLY

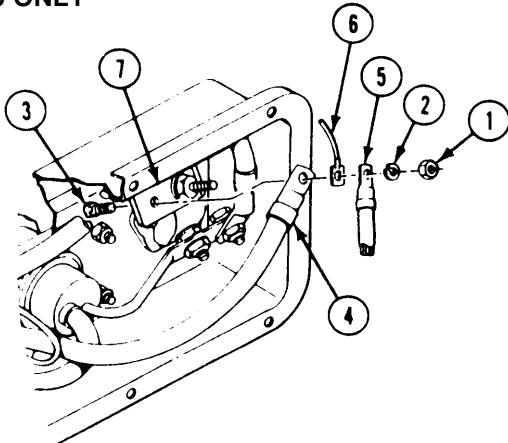

M901A1, M113A2

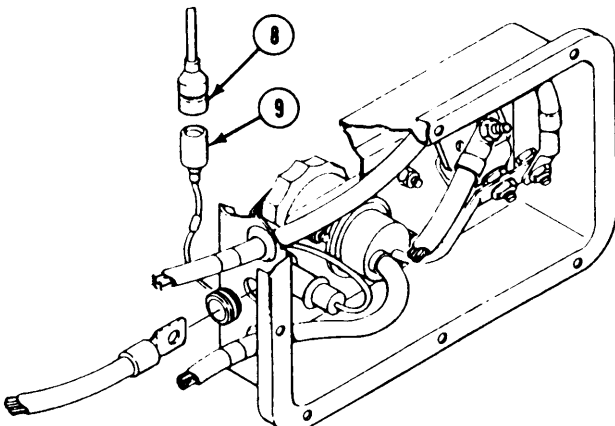

MASTER SWITCH PANEL

39. Remove circuit 400 lead (6) and grommet (10) from distribution box (11). Discard grommet.

40. Disconnect circuit 450 lead (12) from circuit breaker (13).

41. Remove circuit 450 lead (12) and grommet (14) from distribution box (11). Discard grommet.

42. Disconnect circuit 450B lead (15) from circuit breaker (16).

43. Remove circuit 450B lead (15) and grommet (17) from distribution box (11). Discard grommet.

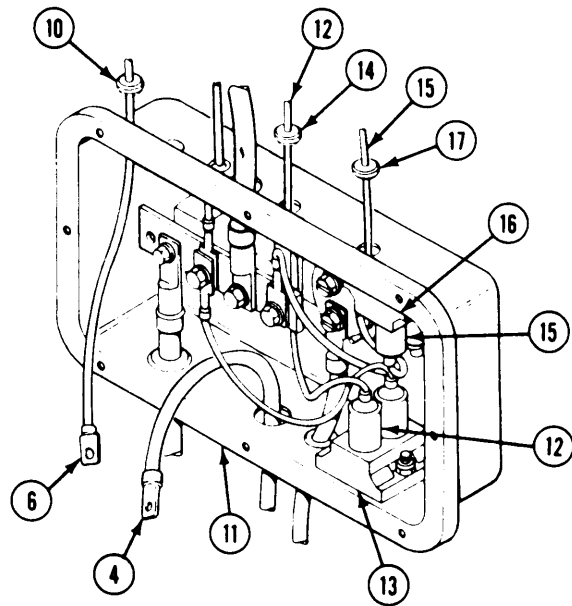

DISTRIBUTION BOX

44. Remove two nuts (1), mounts (2 and 3), flat washers (4), and screws (5) that secure instrument panel (6) to two struts (7).
45. Support panel (6). Remove two screws (8), flat washers (9), one lockwasher (10), and ground lead (11) from two mounts (12) and upper support (13). Discard lockwasher.
46. Support panel (6) on two struts (7) to gain access to rear of panel.
47. Disconnect circuit 28 lead (14) from fuel gage.
48. Disconnect circuit 451B lead (15) from rear bilge pump ON indicator light.
49. Disconnect circuit 38 lead (16) from instrument panel wiring harness.
50. Disconnect circuits 450, 450Bm and 451A leads (17, 18, and 19) from bilge pump switch.
51. Disconnect circuits 21, 22, 23, and 24 leads (20, 21, 22, and 23) from front main wiring harness.
52. Remove rear main wiring harness from carrier (all carriers with inside fuel tank).

INSTALL

53. Install rear main wiring harness in carrier.
54. Connect circuits 24, 23, 22, and 21 leads (23, 22, 21, and 20) to front main wiring harness.
55. Connect circuits 451A, 450B, and 450 leads (19, 18, and 17) to bilge pump switch.
56. Connect circuit 38 lead (16) to instrument panel wiring harness.
57. Connect circuit 451B lead (15) to rear bilge pump ON indicator light.
58. Connect circuit 28 lead (14) to fuel gage.
59. Support instrument panel (6) on two struts (7) .
60. Install ground lead (11) and new lockwasher (10) on upper support (13). Install panel (6) on upper support (13). Install panel (6) with two mounts (12) on support (13). Secure with two screws (8) and flat washers (9).
61. Install panel (6) on two struts (7). Secure with two nuts (1), mounts (2 and 3), flat washers (4), and screws (5).

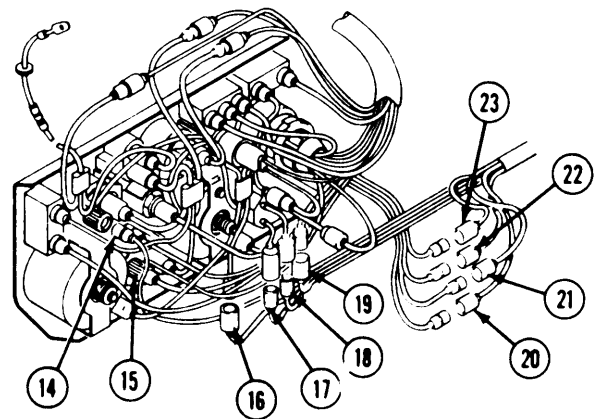
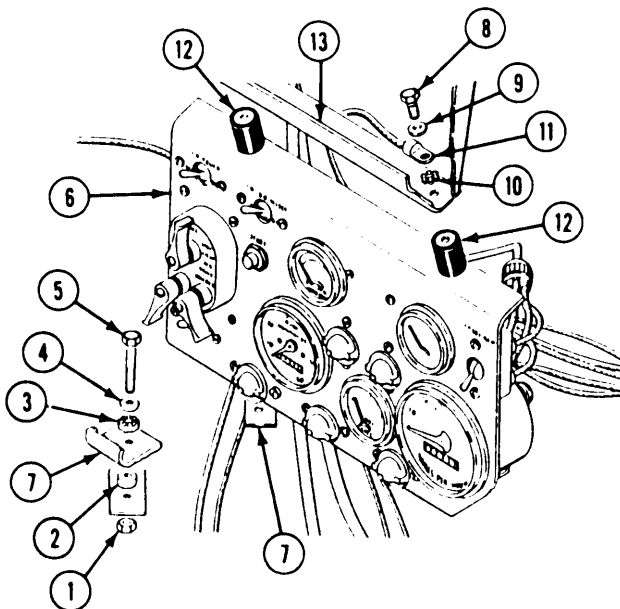

GO TO NEXT PAGE

62. Install new grommet (1) and circuit 450B lead (2) in distribution box (3).

63. Connect circuit 450B lead (2) to circuit breaker (4).

64. Install new grommet (5) and circuit 450 lead (6) in distribution box (3).

65. Connect circuit 450 lead (6) to circuit breaker (7),

66. Install new grommet (8) and circuit 400 lead (9) in distribution box (3).

67. Connect circuit 37 lead (10) to circuit 38 lead (11).

68. Install circuits 400, 2, and 6 leads (9, 12, and 13) on bus bar (14). Secure with screw (15), new lockwasher (16), and nut (17).

69. Install distribution box (3) on master switch panel. Secure with eight screws (18), washers (19), and new locknuts (20).

NOTE

Inspect gasket (21). Replace if damaged.

70. Install rear main wiring harness (22) on guard (23). Secure with three screws (24), nuts (25), and clamps (26).

71. Install guard (23) on two weldnuts (27). Secure with two screws (28) and new lockwashers (29).

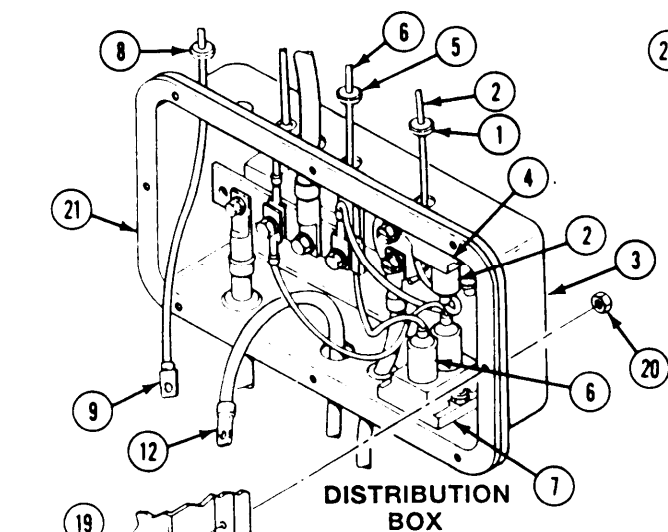

DISTRIBUTION BOX

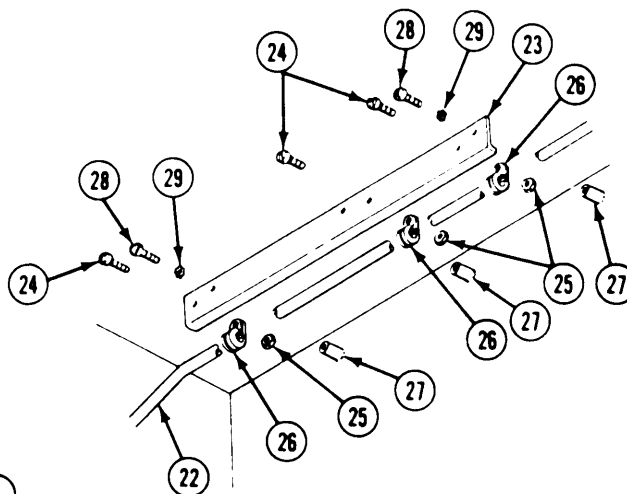

MASTER SWITCH PANEL

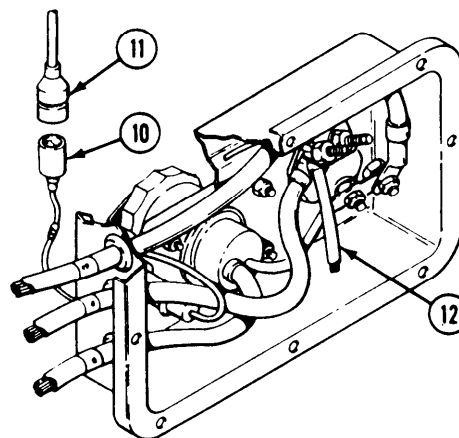
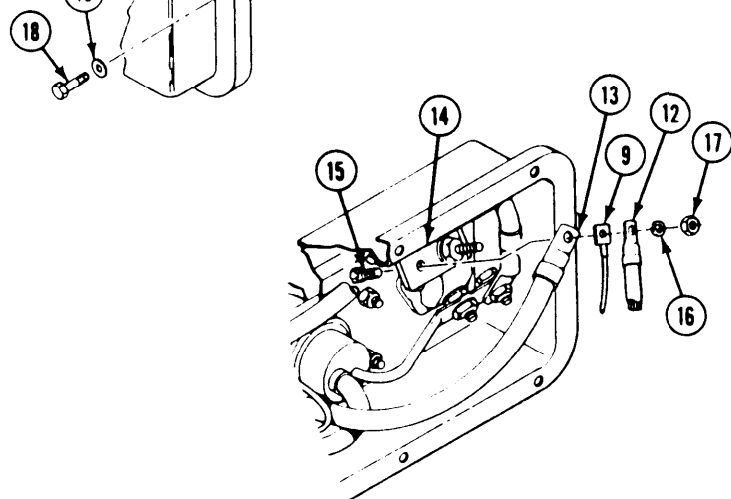

72. Install rear main wiring harness (1) on seven cradles (2). Secure with seven cradle clips (3).
73. If engine coolant heater is installed, connect circuit 402A lead (4) to engine coolant heater wiring harness and circuit 400A lead (5) to engine coolant heater control box.
74. If personnel heater is installed, connect circuit 402 lead (6) to personnel heater wiring harness and circuit 400 lead (7) to personnel heater control box.
75. Connect circuit 38 lead (8) to front dome light (9).
76. Install wiring harness (1) on weldnut (10). Secure with screw (11) and clamp (12).
77. Install wiring harness (1) on two cradles (13). Secure with two cradle clips (14).
78. Install circuit 28 lead (15) in clamp (16). Secure with screw (17).
79. Connect circuit 28 lead (15) to fuel quantity sending unit (18).
80. Install three leads (19, 20, and 21) through nut (22), bushing (23), and connector (24). Tighten nut on connector.
81. Install three new terminals (25), insulators (26), and connectors (27) on the ends of three leads installed in step 86.
82. Connect circuits 24, 22, and 21 leads (21, 20, and 19) to left tail light (28).
83. Install left tail light (28) and guard (29) on hull. Secure with four screws (30) and new lockwashers (31).

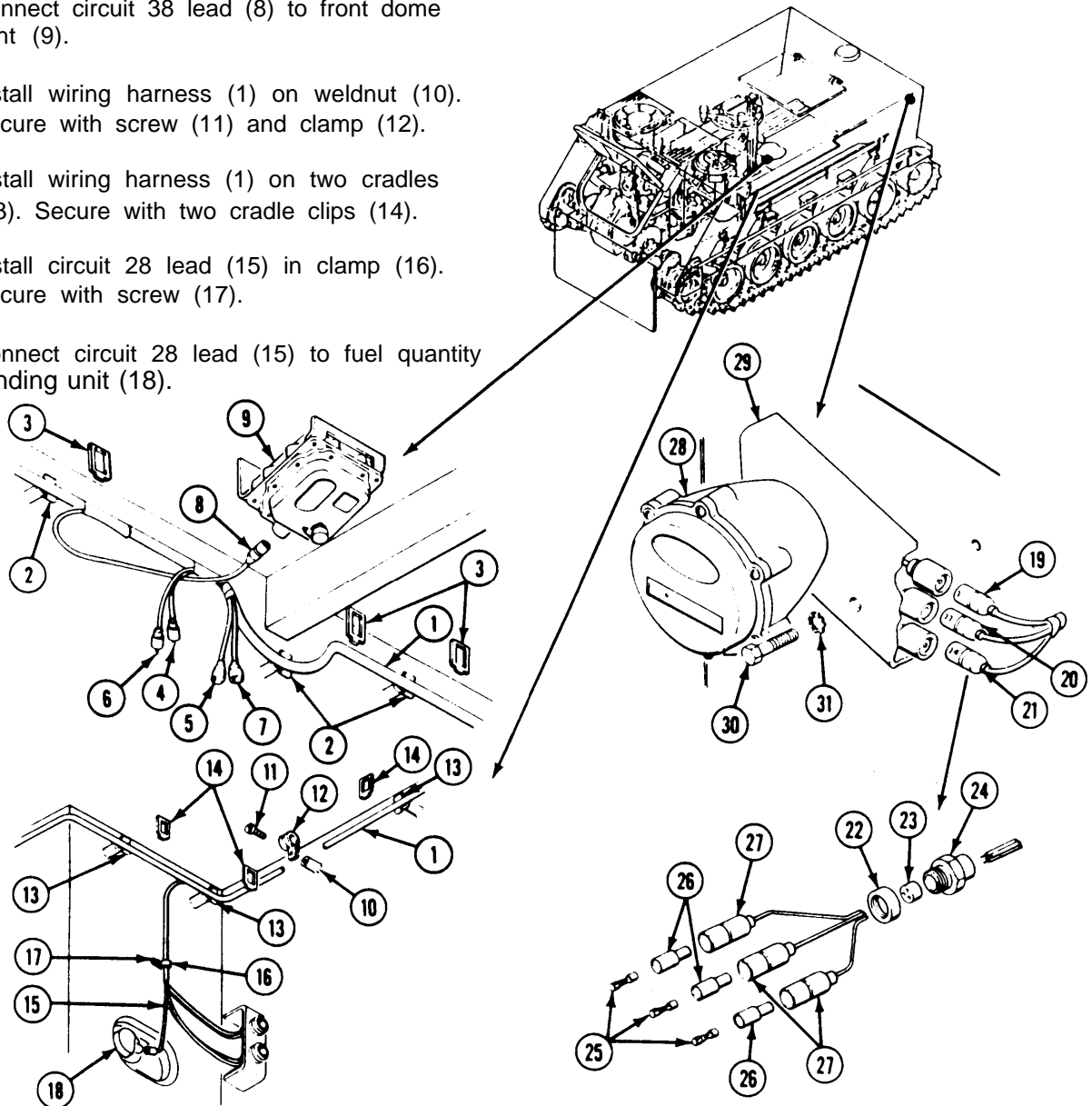

GO TO NEXT PAGE

84. Install rear main wiring harness (1) on guard (2). Secure with two screws (3), nuts (4), and clamps (5).

85. Install guard (2) and ground strap (6) on hull. Secure with two screws (7) and new lockwashers (8).

86. Install wiring harness (1) on cradle (9). Secure with cradle clip (10).

87. Install wiring harness (1) on fuel tube (11). secure with two straps(12).

88. If engine coolant heater is installed, connect circuit 402A lead (13) to engine coolant heater fuel pump (14).

89. If personnel heater is installed, connect circuit 402 lead (15) to personnel heater fuel pump (16).

90. Install circuit 451 lead (17) on two cradles (18). Secure with two cradle clips (19).

91. Install circuit 451 lead (17) on weldnut (20). Secure with screw (21), new lockwasher (22), and clamp (23).

92. Install clamp (24) on circuit 451 lead (17). Secure with screw (25) and nut (26).

93. Install clamp (24) on floor transverse beam (27). Secure with two screws (28) and nuts (29).

94. Install wiring harness (30) and bilge tube clamp (31) on weldnut (32). Secure with screw (33) and clamp (34).

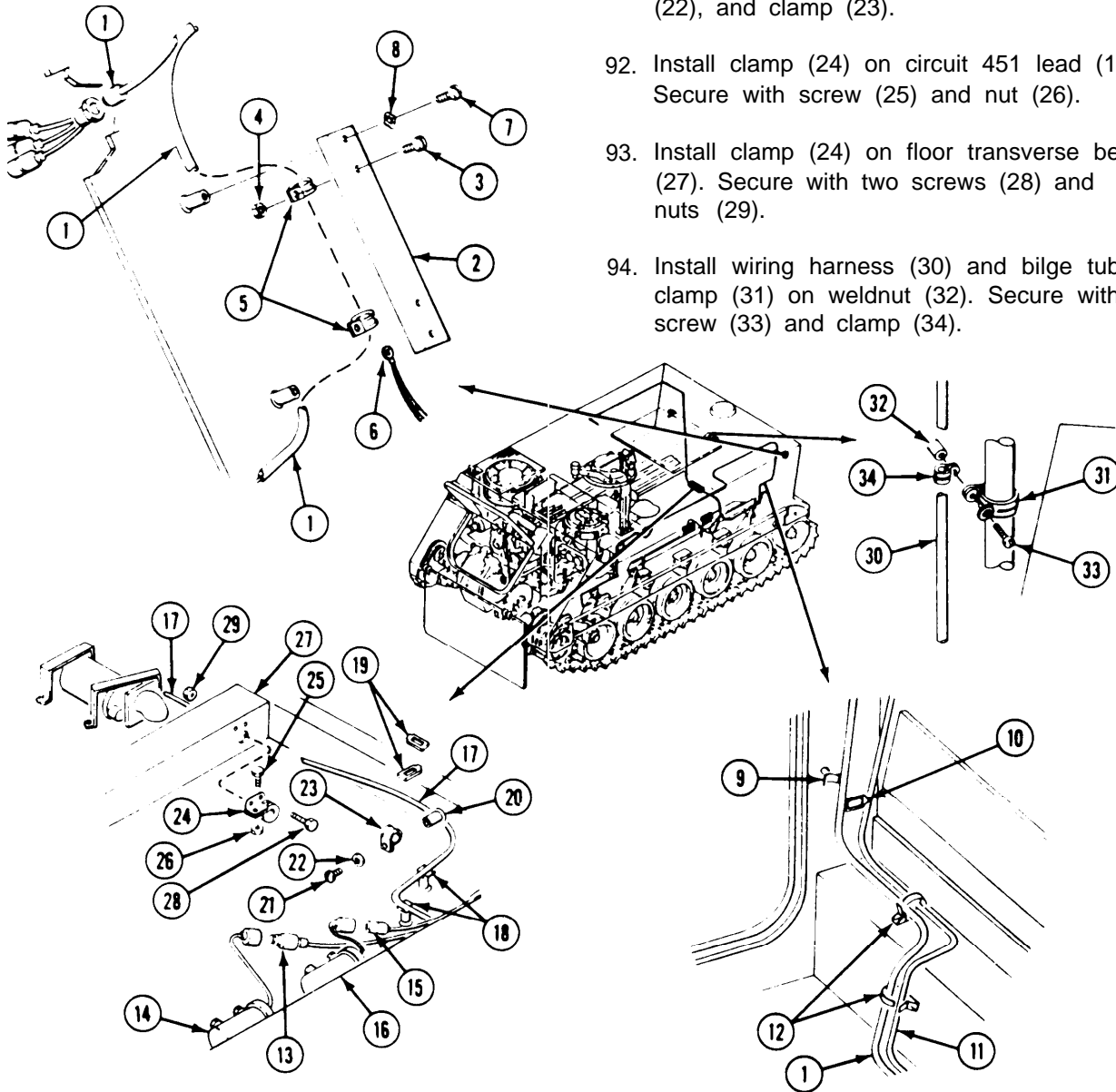

95. Install rear main wiring harness (1), circuit 90 lead (2), and two washers (3) on two weldnuts (4). Secure with two screws (5) and clamps (6).
96. Connect circuits 21, 22, 23, and 24 leads (7, 8, 9, and 10) to trailer wiring harness (11).
97. Connect circuit 451 lead (12) to rear bilge pump (13).

98. Install wiring harness (1) on bilge tube clamp (14). Secure with clamp (15), screw (16), and nut (17).
99. Route circuits 38, 23, and 24 leads (18, 19, and 20) through clamp (21). Secure clamp (21) to tail light (22) with washer (23) and nut (24).
100. Connect circuits 23 and 24 leads (19 and 20) to right tail light (22) female connectors.

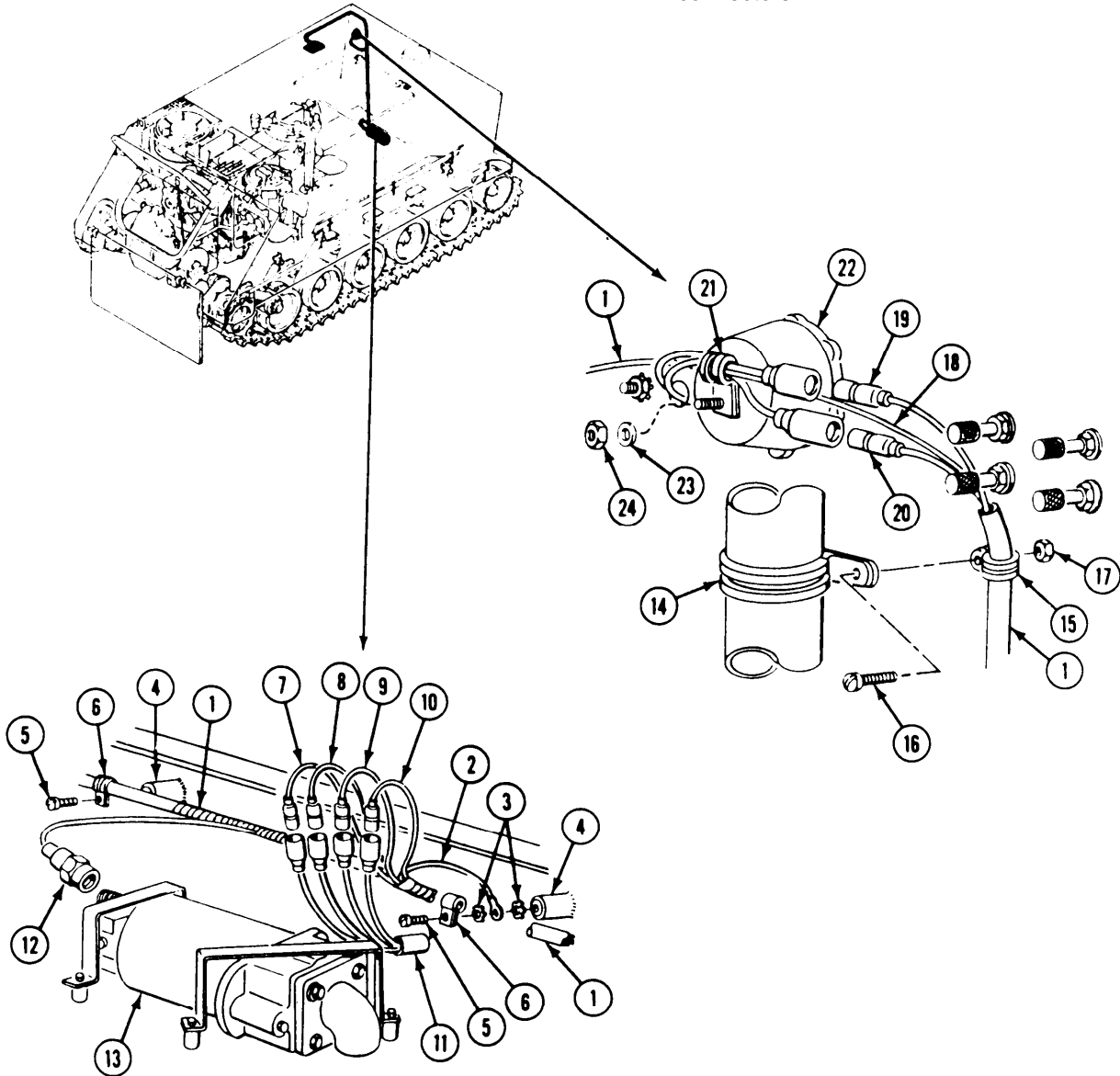

GO TO NEXT PAGE

101. Install circuit 38 lead (1) on three cradles (2). Secure with three cradle clips (3).
102. Install clamp (4) on rear dome light (5). Secure with screw (6) and nut (7).

103. Connect circuit 38 lead (1) to dome light (5).

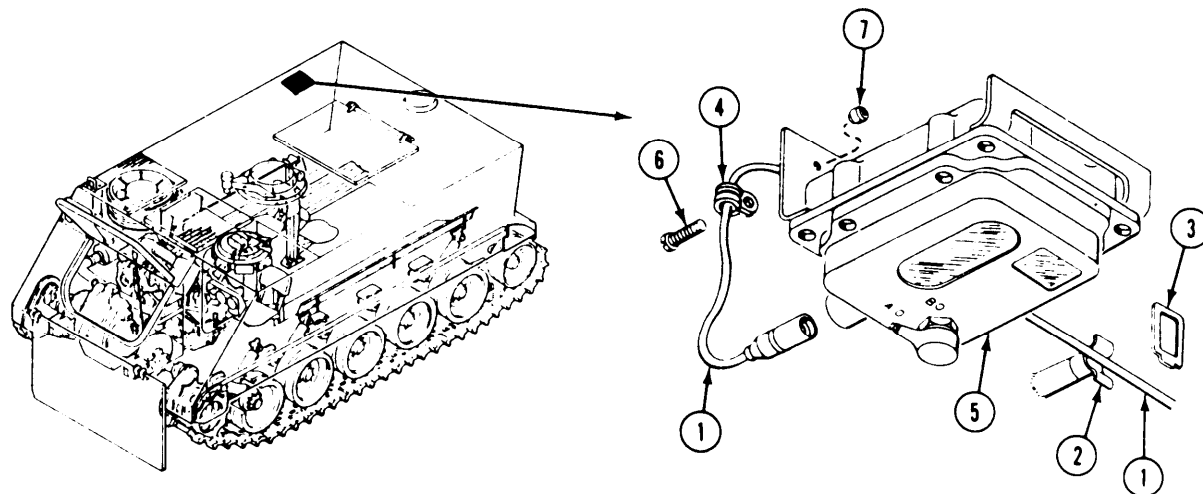

FOLLOW-THROUGH STEPS

1. Install rear floor plate (page 24+7).
2. Connect battery ground lead (page 13-2).
3. Turn MASTER SWITCH ON (see your -10). Check that electrical system works properly.
4. Raise and lock ramp (see your -10).
5. Stop/shutdown engine (see your -10).

END OF TASK

**Section VI. MAINTENANCE OF STOP LIGHT SWITCH AND
INFRARED POWER SUPPLY**

TASK INDEX

<u>Task</u>	<u>Page</u>	<u>Task</u>	<u>Page</u>
Replace Stop Light Switch and Bracket	12-132	Replace Tube type Infrared Power Supply Shock Mount Brackets	12-136
■ Replace Tube type Infrared Power supply	12-134	Replace Solid supply	12-137

REPLACE STOP LIGHT SWITCH AND BRACKET

DESCRIPTION

This task covers: Remove (page 12-132) Install (page 12-132) . Adjust (page 12-133).

INITIAL SETUP

Tools:

General Mechanics Tool Kit (Item 30, App D)

References:

See your -10

Materials/Parts:

Self-locking nut (2)

Equipment Conditions:

Engine stopped/shutdown (see your -10)
 Battery ground lead disconnected (page 13-2)
 Trim vane lowered and power plant front access door open (see your -10)

Personnel Required:

Unit Mechanic

REMOVE

1. Disconnect circuit 75A lead (1) and circuit 75B lead (2) from switch (3).
2. From driver's compartment, remove two screws (4) and washers (5) from driver's bulkhead and bracket (6).
3. From power plant compartment, remove bracket (6) with switch (3) attached.
4. Remove two locknuts (7), four washers (8), two screws (9), and switch (3) from bracket (6). Discard locknuts.

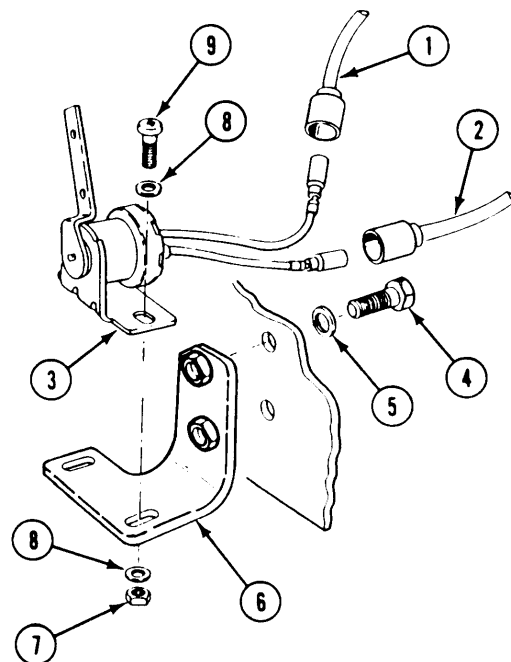

INSTALL

5. Place switch (3) on bracket (6). Secure with two screws (9), four washers (8), and two new locknuts (7).
6. Align bracket (6), with switch (3) attached, to driver's compartment bulkhead. Secure with two washers (5) and screws (4).
7. Connect circuit 75B lead (2) and circuit 75A lead (1) to switch (3).

ADJUST

8. Connect battery ground lead (page 13-2).
9. Turn MASTER SWITCH ON (see your -10).
10. Loosen two screws (1) on switch (2).
11. Pull both steering levers back to first notch and lock levers (see your -10).
12. Place switch (2) against steering levers so that stop light switch comes on.
13. Release steering levers (see your -10). Stop lights should go out.
14. Tighten two screws (1) on switch (2).

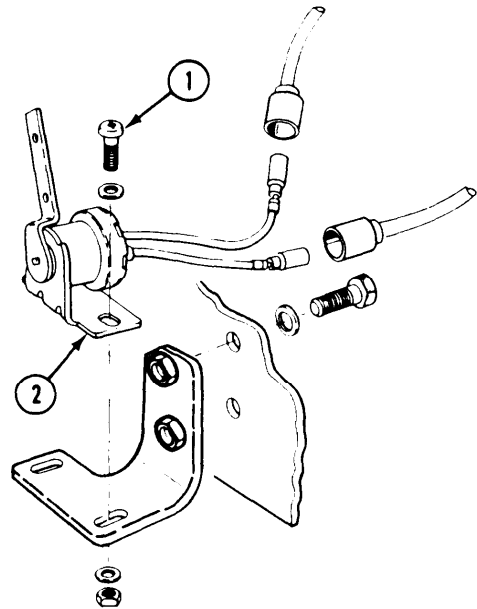
**NOTE**

If movement of switch is not enough to adjust switch, bend tab on steering levers to get correct adjustment.

FOLLOW-THROUGH STEPS

1. Turn all switches OFF (see your -10).
2. Close power plant front access door, and raise trim vane (see your -10).

END OF TASK

REPLACE TUBE TYPE INFRARED POWER SUPPLY

DESCRIPTION

This task covers: Remove (page 12-134). Clean, Inspect, and Repair (page 12-135).
Install (page 12-135).

INITIAL SETUP

Tools:

General Mechanics Tool Kit (Item 30, App D)

Materials/Parts:

Lockwasher (4)

Personnel Required:

Unit Mechanic

References:

see your -10

Equipment Conditions:

Engine stopped/shutdown (see your -10)
Carrier blocked (see your -10)
Battery ground lead disconnected (page 13-2)

REMOVE



WARNING

High voltage in the M19 periscope can cause serious injury or death. To avoid accidents:

ALWAYS connect power cable to periscope **BEFORE** turning master switch and I.R. **POWER** switch **ON**.

After turning I.R. **POWER** and master switches **OFF**, **ALWAYS** wait at least 2 minutes **BEFORE** disconnecting power cable from periscope.

NEVER touch the end of the cable. Voltage could exceed 16,000 volts.

1. Disconnect circuit 516A lead (1) and circuit 517 lead (2) from power supply (3).

2. Remove four nuts (4), four lockwashers (5), ground lead (6), eight washers (7), four screws (8), and power supply (3) from two mounts (9). Discard lockwashers.

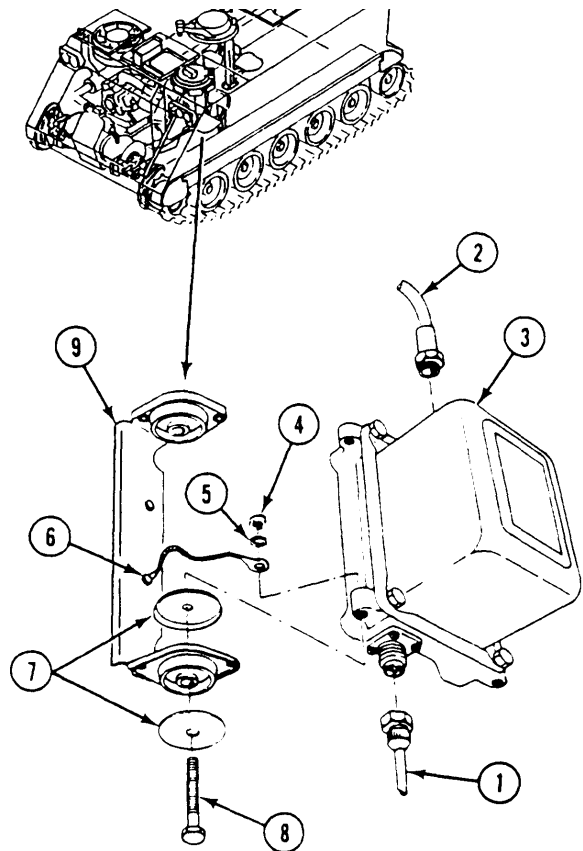

CLEAN, INSPECT, AND REPAIR

3. Check circuit lead connectors (1). Replace connectors that have bent or missing contact pins (page 14-1).

INSTALL

4. Install power supply (2) on two mounts (3). Secure with four screws (4), eight washers (5), ground lead (6), four new lockwashers (7), and nuts (8).
5. Connect circuit 517 lead (9) and circuit 516A lead (10) to power supply (2).

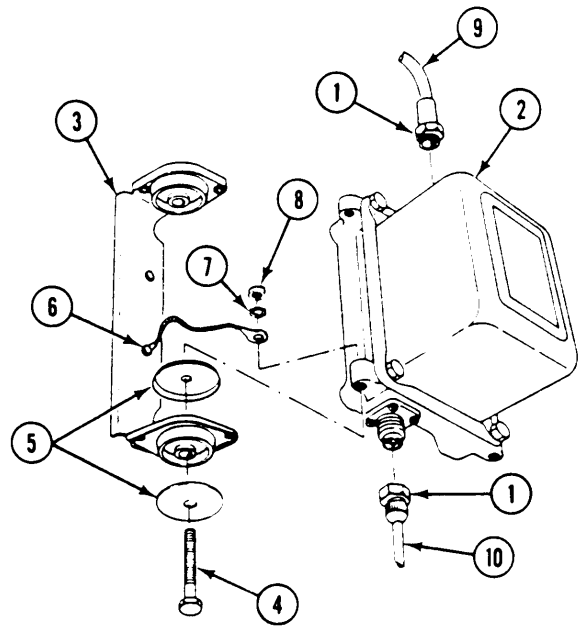

FOLLOW-THROUGH STEPS

1. Connect battery ground lead (page 13-2).
2. Turn MASTER SWITCH ON (see your -10).
3. Install and operate M19 periscope to check that infrared power supply is operable (see your -10).
4. Turn all infrared periscope switches off (see your -10).
5. Turn MASTER SWITCH OFF (see your -10).
6. Stow periscope (see your -10).

END OF TASK

REPLACE INFRARED POWER SUPPLY SHOCK MOUNT BRACKETS

INITIAL SETUP

Tools:

General Mechanics Tool Kit (Item 30, App D)

Personnel Required:

Unit Mechanic

Materials/Parts:

Lockwasher (8)

Equipment Conditions:

Infrared power supply removed (page 12-134)

REMOVE

1. Remove four screws (1), eight lockwashers (2), four flat washers (3), ground strap (4), and two brackets (5) from hull. Discard lockwashers.
2. Remove eight nuts (6), washers (7), screws (8), and four mounts (9) from two brackets (5).

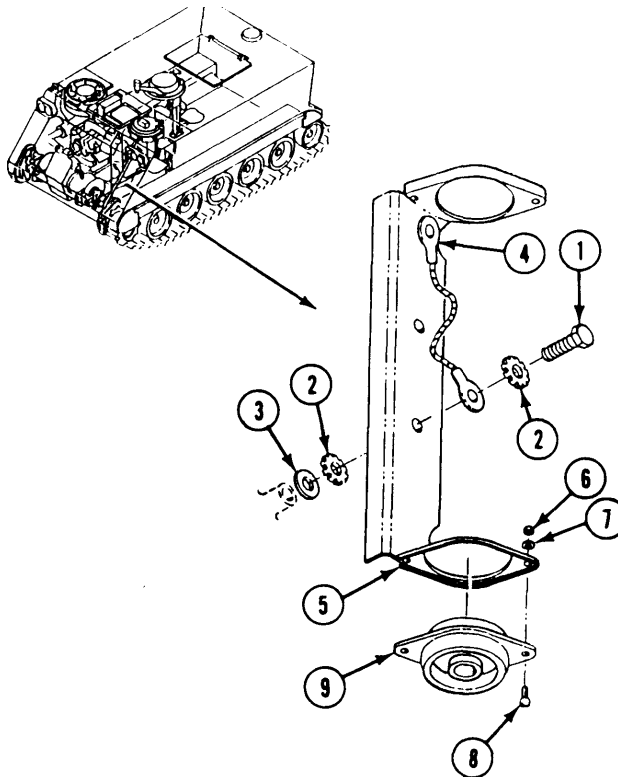

CLEAN, INSPECT, AND REPAIR

3. Check ground lead. Replace frayed, broken, or cracked parts (page 14-3).

INSTALL

4. Install four mounts (9) in two brackets (5). Secure with eight screws (8), washers (7), and nuts (6).
5. Install two brackets (5) on hull. Secure with eight new lockwashers (2), four flat washers (3), ground strap (4), and four screws (1).

FOLLOW-THROUGH STEPS

1. Install infrared power supply (page 12-134).

END OF TASK

REPLACE SOLID STATE INFRARED POWER SUPPLY

DESCRIPTION

This task covers: Remove (page 12-137). Clean, Inspect, and Repair (page 12-138).
Install (page 12-138).

INITIAL SETUP

Tools:

General Mechanics Tool Kit (Item 30, App D)

Materials/Parts:

Lockwasher (8)

Personnel Required:

Unit Mechanic

References:

See your-10

Equipment Conditions:

Engine stopped/shutdown (see your -10)

Carrier blocked (see your -10)

Battery ground lead disconnected (page 13-2)

REMOVE



WARNING

High voltage in the M19 periscope can cause serious injury & death. To avoid accidents:

ALWAYS connect power cable to periscope **BEFORE** turning master switch and I.R. POWER switch **ON**.

After turning I.R. POWER and master switches **OFF**, **ALWAYS** wait at least 2 minutes **BEFORE** disconnecting power cable from periscope.

NEVER touch the end of the cable. Voltage could exceed 16,000 volts.

1. Disconnect circuit 516A lead (1) and circuit 517 lead (2) from power supply (3).

2. Remove four screws (4), eight lockwashers (5), and power supply (3) from four weldnuts.
- Discard lockwashers.

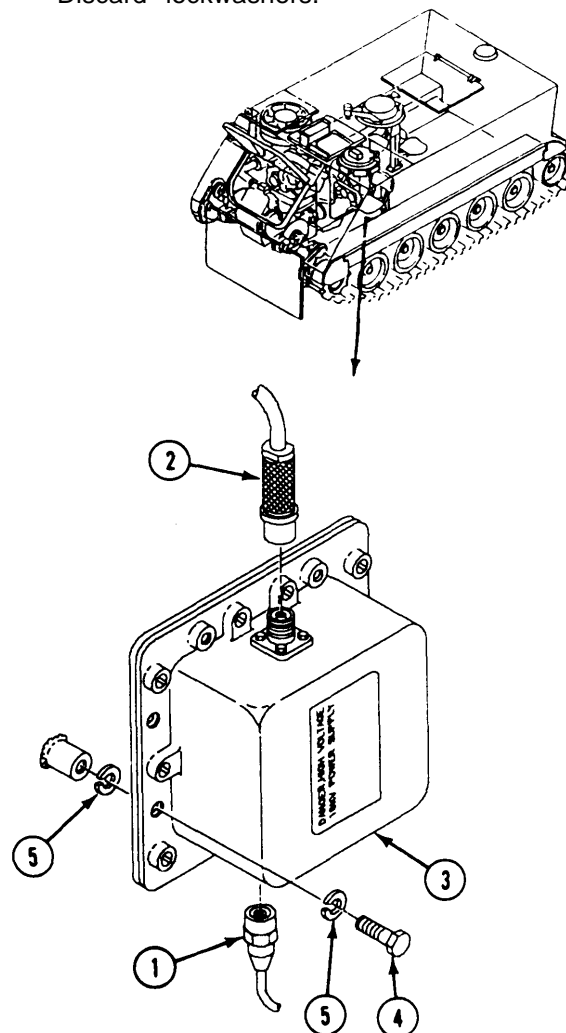

GO TO NEXT PAGE

Change 1

12-137

CLEAN, INSPECT,

3. Check connectors (1). Replace connectors that have bent or missing contact pins (page 14-1).

INSTALL

4. Place power supply (2) on four weldnuts. Secure with four screws (3), and eight lockwashers (4) on weldnuts.
5. Connect circuit 517 lead (5) and circuit 516A lead (6) to power supply (2).

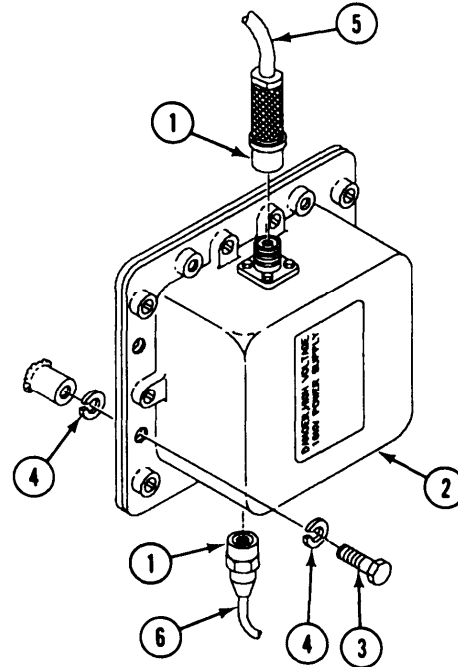

FOLLOW-THROUGH STEPS

- | | |
|---|---|
| <ol style="list-style-type: none"> 1. Connect battery ground lead (page 13-2). 2. Turn MASTER SWITCH ON (see your -10). 3. Install and operate M19 periscope to check that infrared power supply is operable (see your -10). | <ol style="list-style-type: none"> 4. Turn all infrared periscope switches off (see your -10). 5. Turn MASTER SWITCH OFF (see your -10). 6. Stow periscope (see your -10). |
|---|---|

END OF TASK

CHAPTER 13
ELECTRICAL SYSTEM MAINTENANCE-BATTERIES

TASK INDEX

<u>Task</u>	<u>Page</u>	<u>Task</u>	<u>Page</u>
Disconnect/Connect Battery Ground Lead.	13-2	Replace Battery and Retainers (M106A2, M1064, and M125A2 Only)	13-18
Replace Battery Cover and Ground Lead (M113A2, M741A1, M901A1, and M1059)	13-3	Repair Battery Box Cover (M113A2, M901A1, M741A1, and M1059 Only)	13-20
Remove/Install Battery Access Cover (M577A2 only)	13-6	Repair Battery Box (All Except M125A2, M1064, and M106A2)	13-22
Remove/Install Battery Access Cover (M1068 Only)	13-6.1	Repair Battery Drawer (M106A2, M1064, and M125A2 Only)	13-24
Remove/Install Battery Leads (M1068 Only)	13-6.3	Replace Battery to Radio Harness (M1059, M901A1 and M113A2 only)	13-27
Replace Battery Leads (M577A2 only)	13-7	Replace Battery Drawer Insulation and Heat Exchanger (M106A2, M1064, and M125A2 Only)	13-32
Replace Battery Leads (M106A2, M1064, and M125A2 only)	13-10	Replace Battery Box Insulation and Heat Exchanger (M577A2 and M1068 Only)	13-35
Replace Circuit 6 Lead (All except M577A2 and M1068)	13-13	Replace Battery Box Insulation and Heat Exchanger (M113A2, M741A1, M901A1, and M1059 Only)	13-37
Replace Battery and Retainers (All Except M106A2, M1064, and M125A2)	13-16		

DISCONNECT/CONNECT BATTERY GROUND LEAD

INITIAL SETUP

Tools:

General Mechanics Tool Kit (Item 30, App D)
 Battery Terminal Puller (Item 46, App D)

Materials/Parts:

Grease (Item 18, App C)

Personnel Required:

Unit Mechanic

References:

See your -10

Equipment Conditions:

Engine stopped/shutdown (see your -10)
 Ramp lowered (see your -10)
 and radios and heaters OFF (see your -10)
 Battery access (see your -10 page 3-35)
 Battery access cover removed M1068 ONLY
 (page 13-6.1)

DISCONNECT

WARNING



Gas from batteries can explode. Ventilate compartment before you disconnect or connect battery cables. Battery acid can burn or blind you. Do not get acid on your skin or eyes. ALWAYS disconnect ground lead (circuit 7) first and connect it last.

WARNING



Battery posts and cables touched by metal objects can short circuit and burn you. Do not wear jewelry, necklaces, or watches when working on the electrical system. Keep tools away from posts, wires, and terminals.

1. Loosen nut (1) and remove circuit 7 ground lead and terminal lug (2) from battery post (3). Use battery terminal puller.

CONNECT

CAUTION

Battery cells can be damaged if the batteries are connected incorrectly. Be sure batteries are connected correctly.

2. Position circuit 7 ground lead and terminal lug (2) on battery post (3) and tighten nut (1).
3. Coat top of battery post (3) and terminal lug (2) with grease.

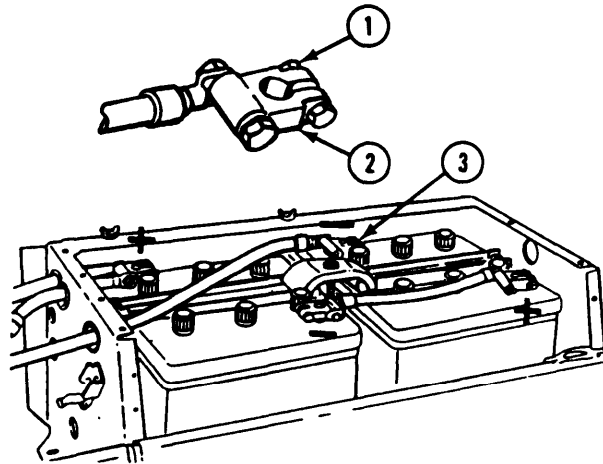

FOLLOW-THROUGH STEPS

1. Secure battery (see your -10 page 3-35).
2. Start engine (see your -10).
3. Raise and lock ramp (see your -10).
4. Stop/shutdown engine (see your -10).

END OF TASK

REPLACE BATTERY COVER AND GROUND LEAD (M113A2, M741A1, M901A1, AND M1059)

DESCRIPTION

This task covers: Remove (page 13-3). Clean, Inspect, and Repair (13-4). Install (page 13-4).

INITIAL SETUP

Tools:

- General Mechanics Tool Kit (Item 30, App D)
- Battery Terminal Cleaner (Item 13, App D)
- Battery Terminal Puller (Item 46, App D)

Materials/Parts:

- Grease (Item 18, App C)
- Sodium Bicarbonate (Item 55, App C)
- Grommet

Personnel Required:

Unit Mechanic

References:

See your -10

Equipment Conditions:

- Engine stopped/shutdown (see your -10)
- Carrier blocked (see your -10)
- Ramp lowered (see your -10)

REMOVE

1. Release two latches (1) on side of battery box: (2). Lift and slide cover (3) from three grommets (4) on rear of battery box. Remove cover.



WARNING

Gas from batteries can explode. Ventilate compartment before you disconnect or connect battery cables. Battery acid can burn or blind you. Do not get acid on your skin or eyes. ALWAYS disconnect ground lead (circuit 7) first and connect it last.

2. Remove circuit 7 lead (5) as follows:
 - a. Remove nut (6) and circuit 7 lead (5) from screw (7) on terminal lug (8).
 - b. loosenut(9) from (10) and remove terminal lug(8)from battery post. use battery terminal puller.

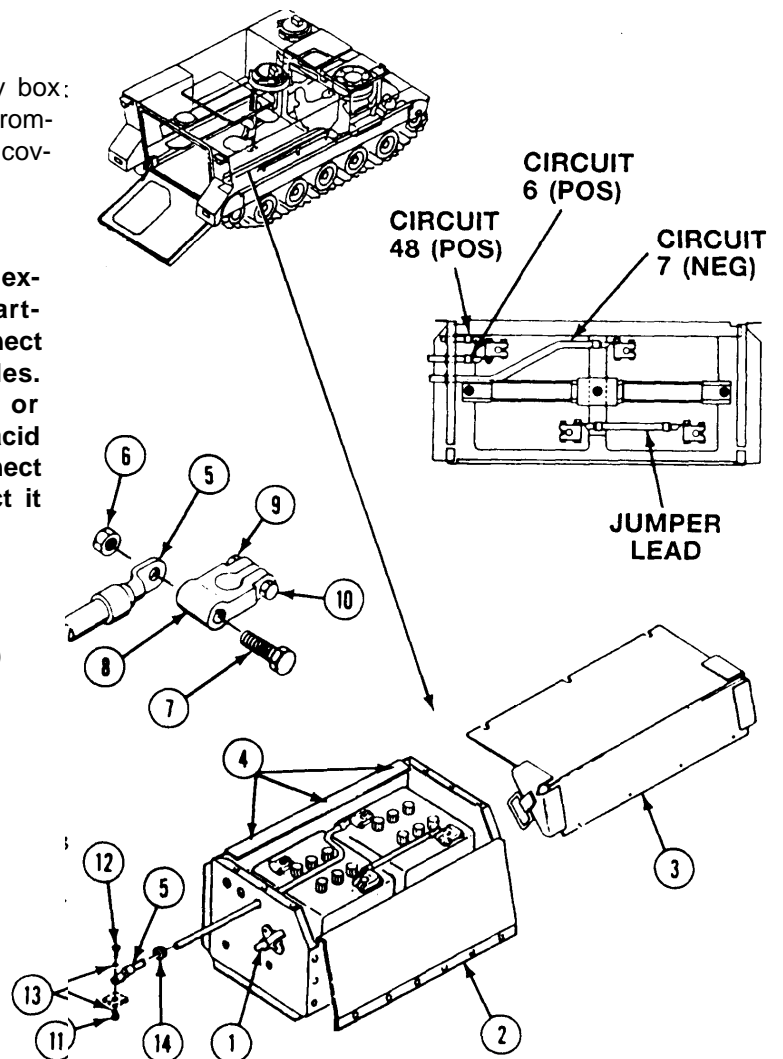

GO TO NEXT PAGE

- Remove two nuts (1) and jumper lead (2) from two screws (3) on two terminal lugs (4).

WARNING



Battery posts and cables touched by metal objects can short circuit and bum you. Do not wear jewelry, necklaces, or watches when working on the electrical system. Keep tools away from posts, wires, and terminals.

CAUTION

Do not start carriers while batteries are disconnected. Starting engine with outside power while batteries are disconnected will damage electrical components in the regulator.

- Loosen two nuts (5) on two screws (6) and remove terminal lugs from battery posts. Use battery terminal puller.

CLEAN, INSPECT, AND REPAIR

- Clean battery terminal adapters, battery posts, grounding bracket on hull, and lead connectors with brush dipped in mixture of sodium bicarbonate and water. After foaming stops, flush parts with clean water. Dry with clean cloth.
- Clean terminals lugs and posts with terminal cleaner.
- Check leads. Replace worn leads aged connectors (page 14-3).

INSTALL

CAUTION

Battery cells can be damaged if the batteries are hooked up incorrectly. Make sure batteries are hooked up correctly.

- Place two terminal lugs (4) on battery posts. Secure with two screws (6) and nuts (5).
- Place jumper lead (2) on two screws (3) of two terminal lugs (4). Secure with two nuts (1).

NOTE

Install circuits 6 and 48 positive leads before installing circuit 7 ground lead.

- Install circuit 7 lead (7) as follows:
 - Place lead (7) on hull mount. Secure with two washers (8), screw (9) and nut (10).
 - Install new grommet (11) in battery box (12). Route circuit lead 7 (7) through grommet into battery box.
 - Place circuit 7 lead (7) on screw (3) in terminal lug (4) of battery closest to the ramp door. Secure with nut (1).

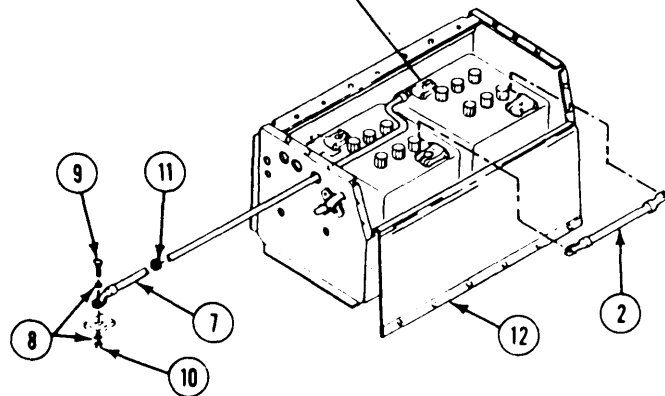
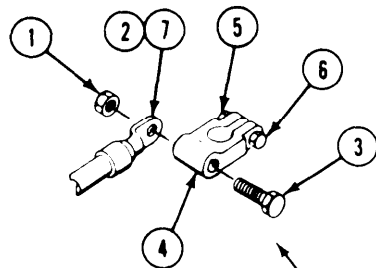
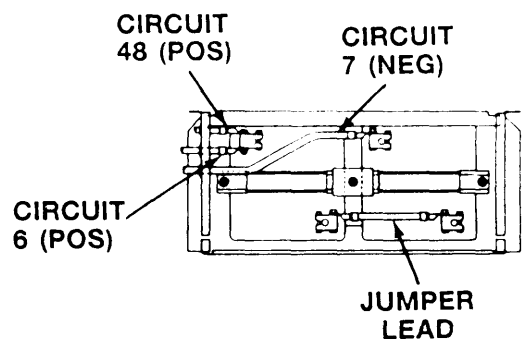

11. Coat tops of four battery terminal lugs (1) with grease.
12. Slide battery cover (2) onto three grommets (3) on battery box (4). Secure cover to battery box with two latches (5) on side of box.

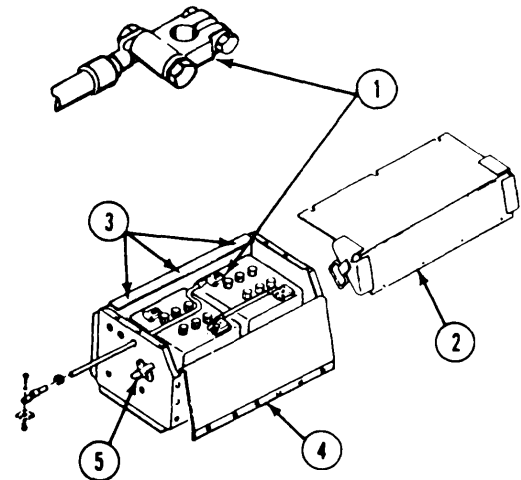
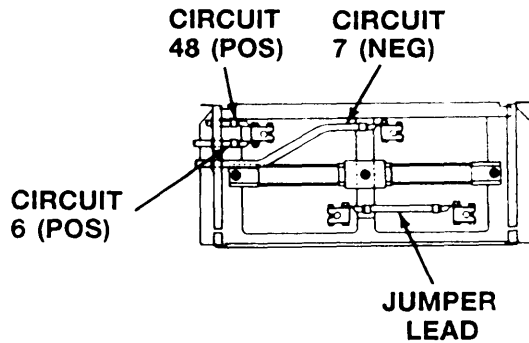

FOLLOW-THROUGH STEPS

1. Turn MASTER SWITCH ON. Check BATT-GEN gage on instrument panel. Gage should read in BATT green or yellow zone (see your -10).
2. Start engine. Raise and lock ramp (see your -10).
3. Stop/shutdown engine (see your -10).

END OF TASK

REMOVE/INSTALL BATTERY ACCESS COVER (M577A2 ONLY)

INITIAL SETUP

Personnel Required:

Unit Mechanic

References:

See your -10

Material/Parts:

Nonmetallic bumper (5)

Equipment Conditions:

Engine stopped/shutdown (see your -10)

REMOVE

1. Raise right forward table (1). Secure with support rod (2) and remove three wing nuts (3).
2. Lift and slide cover (4) from battery box.
3. Remove five nonmetallic bumpers (5) from cover. Discard bumpers.

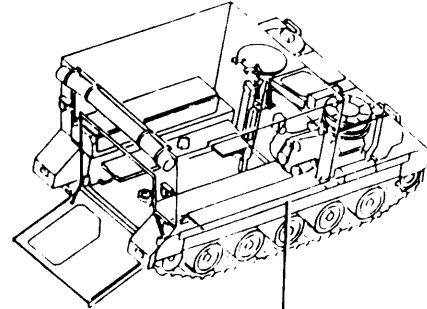

INSTALL

4. Install five new nonmetallic bumpers (5) in battery box cover (4).
5. Slide cover (4) onto battery box. Secure with three wing nuts (3).
6. Lower support rod (2) and right forward table (1).

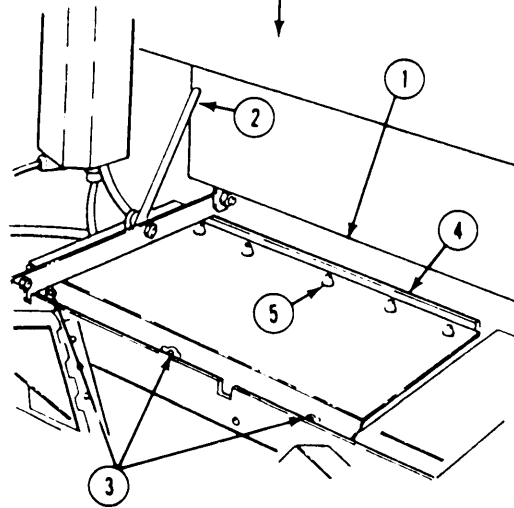

END OF TASK

REMOVE/INSTALL BATTERY ACCESS COVER (M1068 ONLY)

DESCRIPTION

This task covers: Remove (page 13-6.1). Install (page 13-6.2).

INITIAL SETUP

TOOLS:

General Mechanics Tool Kit (Item 30, App D)

Personnel Required:

Unit Mechanic

References:

See your -10

Equipment Conditions:

Engine stopped/shutdown (see your -10)
Carrier blocked (see your -10)

REMOVE

1. Loosen wing nut (1) on FAX hinged base extension support (2).

2. Raise FAX hinged base extension (3) and secure to FAX mount assembly (4) with web strap (5) in slot (6).

3. Loosen three wing nuts (7) and remove battery box cover (8).

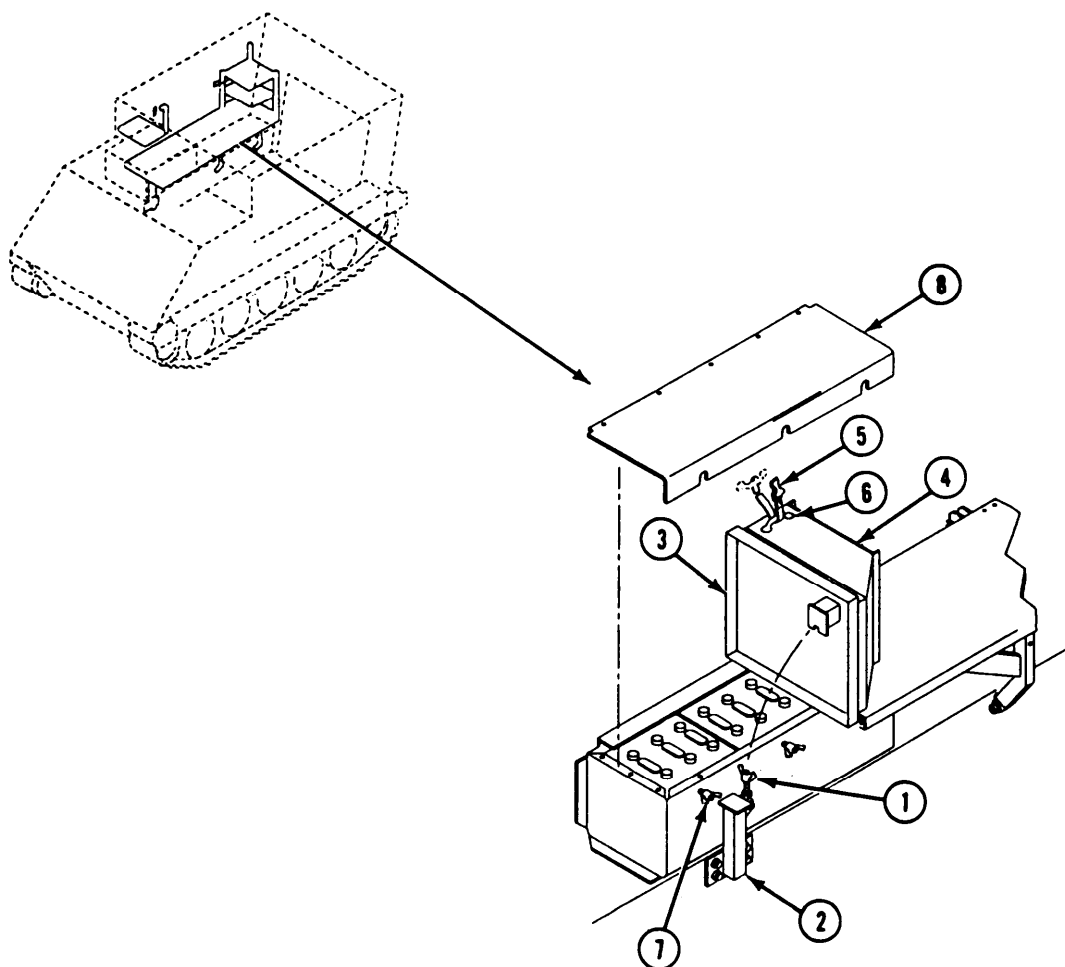

GO TO NEXT PAGE

INSTALL

4. install battery box cover (1) and tighten three wing nuts (2).
5. Remove web strap (3) from slot (4) on FAX mount assembly (5) and lower FAX hinged base extension (6).
6. Tighten nut (7) on FAX hinge base extension support (8).

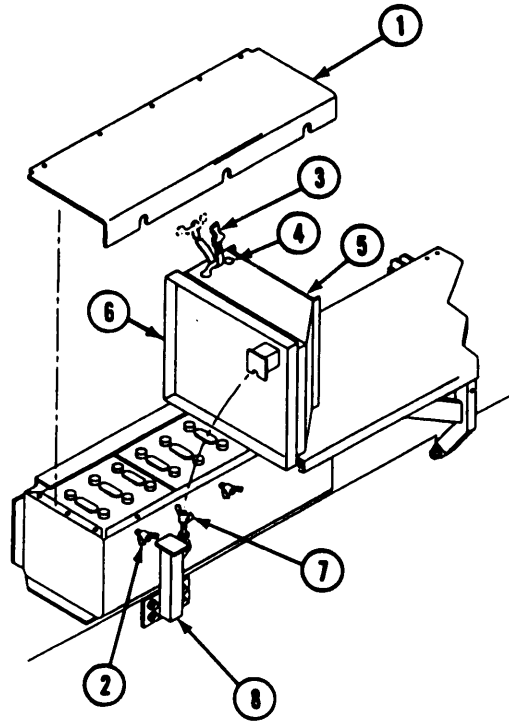

END OF TASK

REMOVE/INSTALL BATTERY LEADS (M1068 ONLY)

DESCRIPTION

This task covers: Remove (page 13-6.3). Clean, Inspect, and Repair (page 13-6.4).
Install (page 13-6.5).

INITIAL SETUP

Tools:

General Mechanics Tool Kit (Item 30, App D)
Battery Terminal Cleaner (Item 13, App D)
Battery Terminal Puller (Item 46, App D)

Materials/Part

Grease (Item 18, App C)
Sodium Bicarbonate (Item 55, App C)
Grommet (2)

Personnel Required:

Unit Mechanic

References:

see your -10

Equipment Conditions:

Engine stopped (see your -10)
Carrier blocked (see your -10)
Ramp lowered (see your -10)
Battery access cover removed (page 13-6.1)
Battery ground lead disconnected (page 13-2)



WARNING

Gas from batteries can explode and injure you. Do not allow sparks near batteries. Battery acid can burn or blind you. Do not get acid on your skin or eyes.

eyes.



WARNING

Electrical current can burn you. Disconnect battery ground lead before you start task

CAUTION

Do not start engine without batteries installed. Starting engine with outside power will cause damage to electrical components in the regulator.

REMOVE

1. Remove jumper lead (1) as follows:

- a. Remove nut (2), jumper lead (1), and screw (3) horn battery positive terminal (4).

Remove nut (2), jumper lead (1), and screw (3) from battery negative

b.

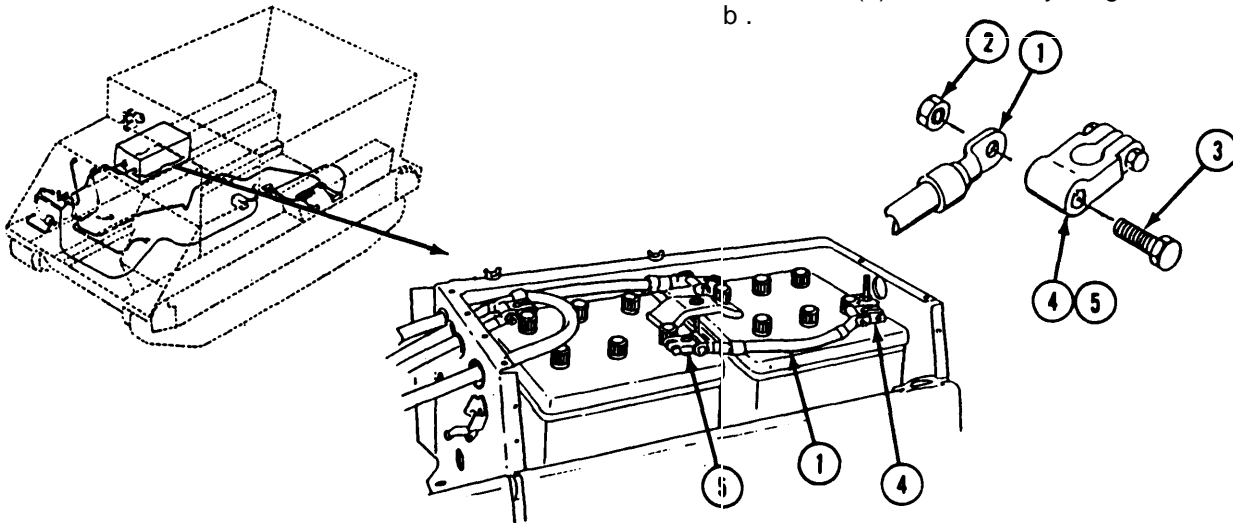

GO TO NEXT PAGE

2. Remove four circuit leads (1, 2, 3, and 4) as follows:
 - a. Remove nut (5), circuit lead 7 (l), and screw (6) from battery negative terminal (7).
 - b. Remove nut (8), screw (9), two washers (10), and circuit lead 7 (1) from hull mount.
 - c. Remove nut (5), screw (6), circuit 31 lead (2), circuit 48B lead (3), and circuit 6 lead (4) from battery positive terminal (11).
 - d. Remove circuit 7 lead (l), circuit 31 lead (2), circuit 6 lead (4), and three-hole grommet (12) from battery box (13). Discard grommet.
 - e. Remove circuit 48B lead (3) and grommet (14) from battery box (13). Discard grommet.

3. Remove four nuts (15), screws (16), and four battery terminals (7 and 11) from battery box (13). Use battery terminal puller.

CLEAN, INSPECT, AND REPAIR

4. Clean battery terminals, battery posts, grounding bracket on hull, and lead connectors with brush dipped in mixture of sodium bicarbonate and water. After foaming stops, flush parts with clean water. Dry with clean cloth.
5. Clean battery terminals and posts with battery terminal cleaner.
6. Check battery cover. Remove dents. Repair cracks. Replace cover damaged beyond repair.
7. Check leads. Replace worn leads and

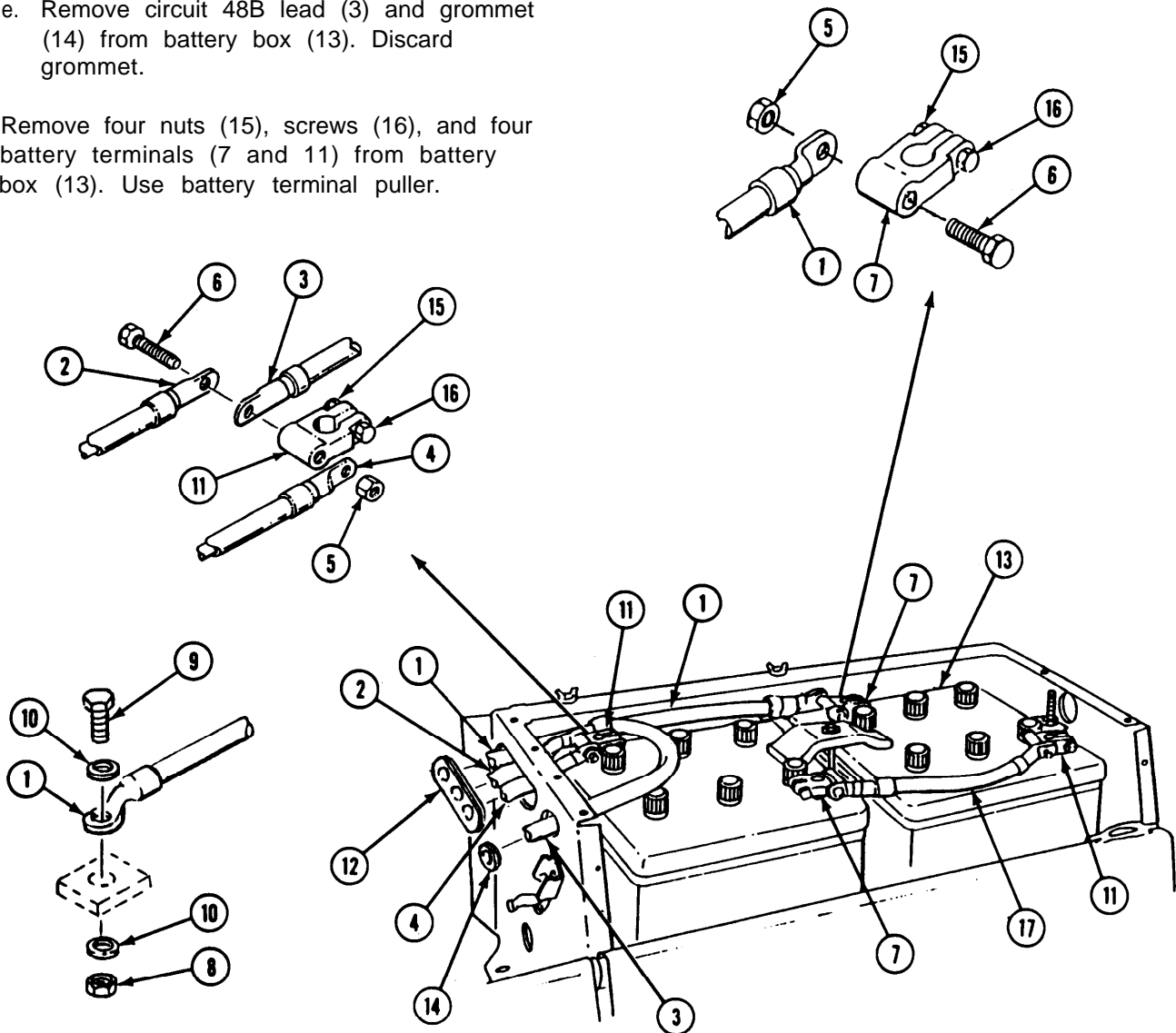

INSTALL

CAUTION

Battery cells can be damaged if battery is hooked up incorrectly. Make sure battery is hooked up correctly.

8. Install four battery terminals (1 and 2) in battery box (3). Secure with four screws (4) and nuts (5).
9. Install four circuit leads (6, 7, 8, and 9) as follows:
 - a. Install two new grommets (10 and 11) in battery box (3).
 - b. Route circuit 6 lead (6), circuit 31 lead (7), and circuit 7 lead (8) through three-hole grommet (10) into battery box (3).
 - c. Route circuit 48B lead (9) through grommet (11) into battery box (3).
 - d. Install circuit 48B lead (9), circuit 31 lead (7), and circuit 6 lead (6) on battery positive terminal (1). Secure with screw (12) and nut (13).
- e. Install circuit 7 lead (8) on battery negative terminal (2). Secure with screw (12) and nut (13).
- f. Install circuit 7 lead (8) on hull mount. Secure with two washers (14), screw (15), and nut (16).
10. Install jumper lead (17) as follows:
 - a. Install jumper lead (17) on battery negative terminal (2). Secure with screw (12) and nut (13).
 - b. Install jumper lead (17) on battery positive terminal (1). Secure with screw (12) and nut (13).
11. Coat tops of four battery terminals (1 and 2) with grease.

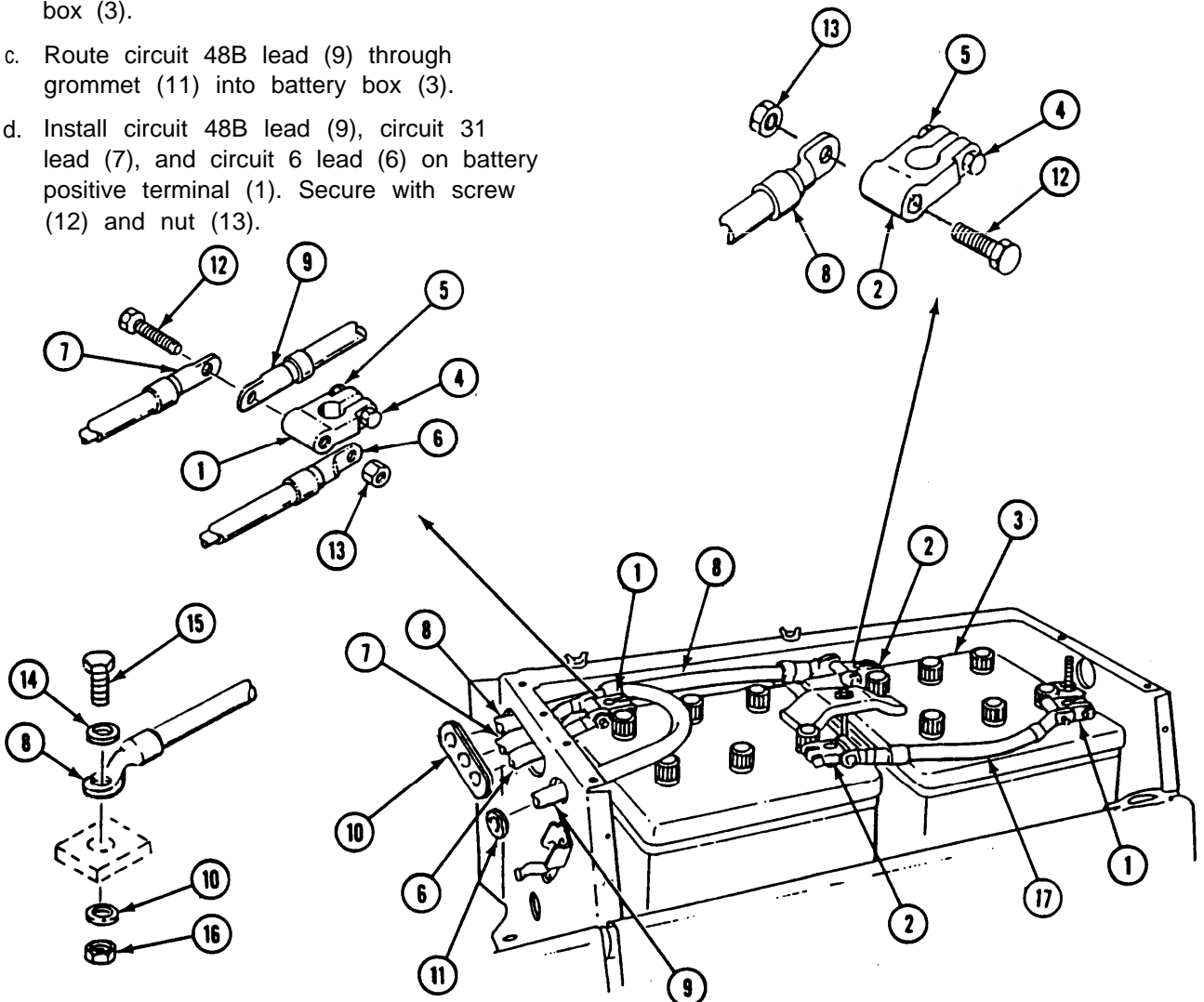

GO TO NEXT PAGE

FOLLOW-THROUGH STEPS

1. Install battery access cover (page 13-6.1).
2. Connect battery ground lead (page 13-2.
3. Turn MASTER SWITCH ON. Check BATT-GEN gage on instrument panel. Gage should read in BATT green or yellow zone (see your -10).
4. Start engine (see your -10).
5. Raise and lock ramp (see your -10).
6. Turn MASTER SWITCH OFF (see your -10).

END OF TASK

REPLACE BATTERY LEADS (M577A2 ONLY)

DESCRIPTION

This task covers: Remove (page 13-7). Clean, Inspect, and Repair (page 13-8).
Install (page 13-8).

INITIAL SETUP

Tools:

General Mechanics Tool Kit (Item 30, App D)
Battery Terminal Cleaner (Item 13, App D)
Battery Terminal Puller (Item 46, App D)

Materials/Parts:

Grease (Item 18, App C)
Sodium Bicarbonate (Item 55, App C)
Grommet (3)

Personnel Required:

Unit Mechanic

References:

See your -10

Equipment Conditions:

Engine stopped (see your -10)
Carrier blocked (see your -10)
Ramp lowered (see your -10)
Battery access cover removed (page 13-6)



WARNING

Gas from batteries can explode and injure you. Do not allow sparks near batteries. Battery acid can burn or blind you. Do not get acid on your skin or

eyes.



WARNING

Electrical current can burn you. Disconnect battery ground lead before you start task.

CAUTION

Do not start carriers without batteries installed. Starting engine with outside power will cause damage to electrical components in the regulator.

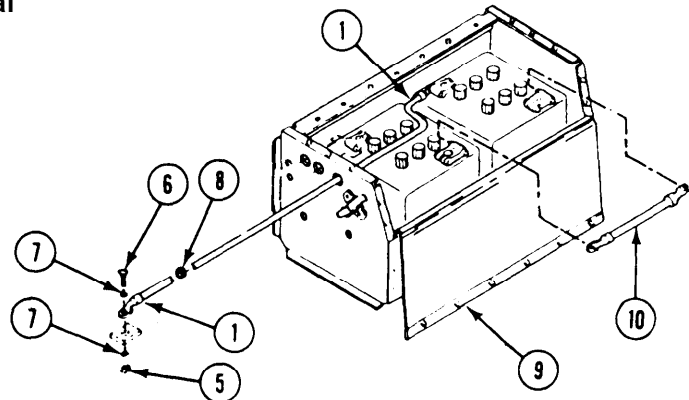
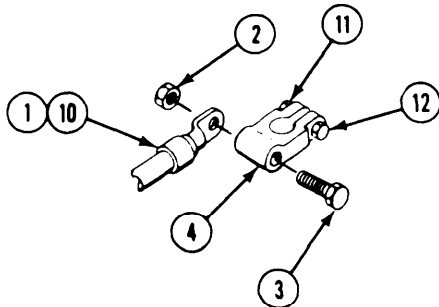

REMOVE

1. Remove circuit 7 lead (1) as follows:
 - a. Remove nut (2) and circuit 7 lead (1) from screw (3) on battery terminal lug (4).
 - b. Remove nut (5), screw (6), two washers (7), and lead (1) from hull mount. Remove lead and grommet (8) from battery box (9). Discard grommet.
2. Remove two nuts (2) and jumper lead (10) from two screws (3) on two terminal lug (4).
3. Loosen nut (11) from screw (12) and remove terminal lug (4) from battery post. Use battery terminal puller.

GO TO NEXT PAGE

4. Remove circuit 6 lead (1) and circuit 48B lead (2) as follows:
 - a. Remove nut (3) circuit 6 lead (1), screw (4) and circuit 48B lead (2) from battery terminal lug (5).
 - b. Remove circuit leads 6 and 48B (1 and 2) and two grommets (6) from battery box. Discard grommets.
 - c. Loosen nut (7) on screw (8) and remove terminal lug (5). Use battery terminal puller.

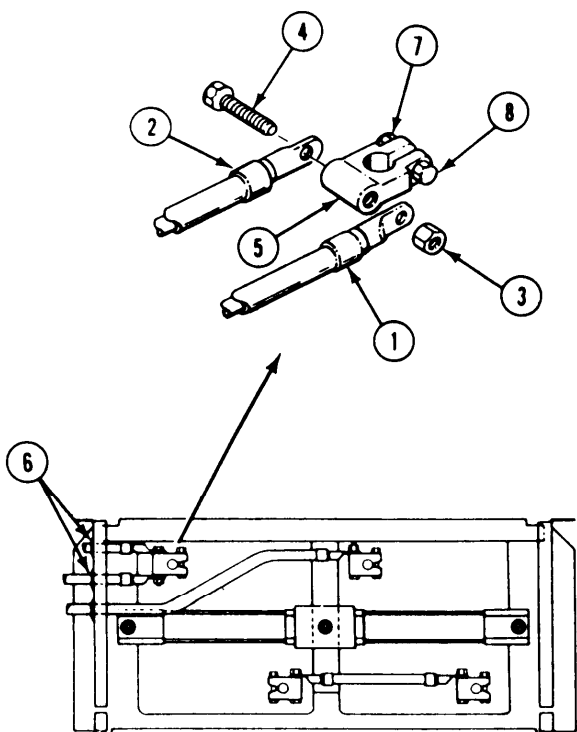

CLEAN, INSPECT, AND REPAIR

5. Clean battery terminal lugs, battery posts, grounding bracket on hull, and lead connectors with brush dipped in mixture of sodium bicarbonate and water. After foaming stops, flush parts with clean water. Dry with clean cloth.
6. Clean battery terminals and posts with battery terminal cleaner.
7. Check battery cover. Remove dents. Repair cracks. Replace cover damaged beyond repair.
8. Check leads. Replace worn leads and damaged connectors (page 14-3).

INSTALL

CAUTION

Battery cells can be damaged if the battery is hooked up incorrectly. Make sure battery is hooked up correctly.

9. Install circuit 6 lead (1) and circuit 48B lead (2) as follows:
 - a. Install terminal lug (5) on positive (+) battery post. Secure with screw (8) and nut (7).
 - b. Install two new grommets (6) in battery box. Route circuit 6 lead (1) and 48B (2) through grommets into battery box.
 - c. Install screw (4), circuit 48B lead (2) and circuit 6 lead (1) on terminal lug (6) and secure with nut (3).

10. Place terminal lug (1) on battery post. Secure with screw (2) and nut (3).
11. Place jumper lead (4) on two screws (5) of two terminal lugs (1). Secure with two nuts (6).
12. Install circuit 7 lead (7) as follows:
 - a. Place lead (7) on hull mount. Secure with two washers (8), screw (9), and nut (10).
 - b. Install new grommet (11) in battery box (12). Route lead (7) through grommet into battery box.
 - c. Place lead (7) on screw (5) of terminal adapter (1) and secure with nut (6).
13. Coat tops of four battery terminal lugs with grease.

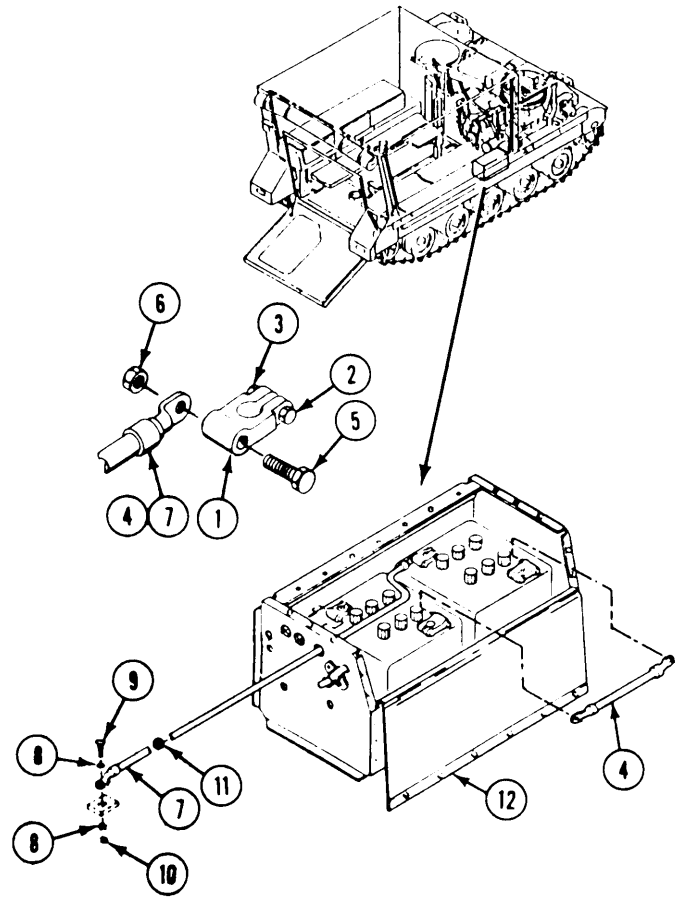

FOLLOW-THROUGH STEPS

1. Install battery access cover (page 13-6).
2. Turn MASTER SWITCH ON. Check BATT-GEN gage on instrument panel. Gage should read in BATT green or yellow zone (see your -10).
3. Start engine (see your -10).
4. Raise and lock ramp (see your -10).
5. Stop/shutdown engine (see your -10).

END OF TASK

REPLACE BATTERY LEADS (M106AZ, M125A2, AND M1064 ONLY)

DESCRIPTION

This task covers: Remove (page 13-10). Clean, Inspect, and Repair (page 13-11).
Install (page 13-11).

INITIAL SETUP

Tools:

General Mechanics Tool Kit (Item 30, App D)
Battery Terminal Cleaner (Item 13, App D)
Battery Terminal Puller (Item 46, App D)

Materials/Parts:

Grease (Item 18, App C)
Sodium bicarbonate (Item 55, App C)
Grommet

Personnel Required:

Unit Mechanic

References:

See your -10

Equipment Conditions:

Engine stopped/shutdown (see your -10)
Carrier blocked (see your -10)
Ramp lowered (see your -10)

REMOVE

1. Turn handle and pull battery drawer (1) out.



WARNING

Gas from batteries can explode and injure you. Do not allow sparks near batteries. Battery acid can burn or blind you. Do not get acid on your skin or eyes. ALWAYS disconnect ground lead (circuit 7) first and connect it last.

NOTE

Use battery terminal puller to remove terminal lugs and leads from battery post.

2. Remove circuit 7 lead (2) as follows:
 - a. Remove nut (3) and circuit 7 lead (2) from screw (4) on terminal lugs (5).
 - b. Remove nut (6), screw (7), two washers (S), and lead (2) from hull mount. Remove lead and grommet (9) from battery compartment. Discard grommet.

NOTE

Circuit 6 and 48 positive leads are removed from terminal lugs the same way as the circuit 7 lead.

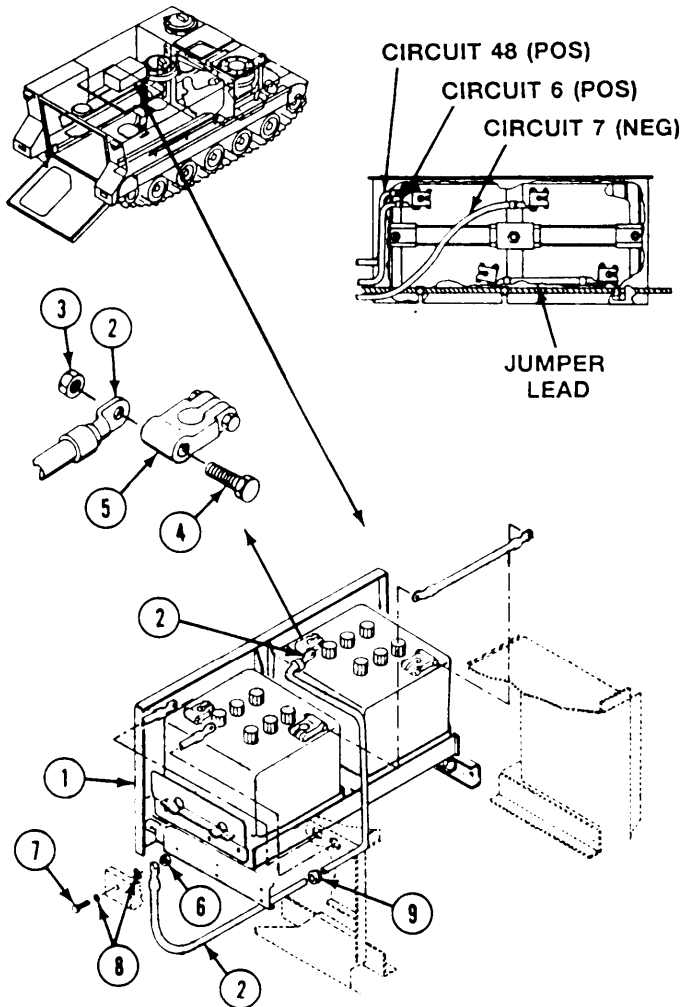

WARNING



Battery posts and cables touched by metal objects can short circuit and bum you. Do not wear jewelry, necklaces, or watches when working on the electrical system. Keep tools away from posts, wires, and terminals.

Keep tools away from posts, wires, and terminals.

CAUTION

Do not start carriers while batteries are disconnected. Starting engine with outside power while batteries are disconnected will damage electrical components in the regulator.

3. Remove two nuts (1) and jumper lead (2) from two screws (3) on two terminal lugs (4).
4. Loosen nut (5) on screw (6) and remove terminal lugs (4) from battery post.

CLEAN, INSPECT, AND REPAIR

5. Clean battery terminal lugs, battery posts, grounding bracket on hull, and lead connectors with brush dipped in mixture of sodium bicarbonate and water. After foaming stops, flush parts with clean water. Dry with clean cloth.
6. Clean terminals and posts with terminal cleaner.
7. Check leads. Replace worn leads and damaged connectors (page 14-3).

INSTALL

8. Place terminal lugs (4) on battery (7). Secure with screw (6) and nut (5).
9. Place jumper lead (2) on two screws (3) of terminal lugs (4). Secure with two nuts (1).

NOTE

Install circuit 6 and 48 positive leads before installing circuit 7 ground lead. Instructions for installation are the same.

10. Install circuit 7 lead (8) as follows:
 - a. Place lead (8) on hull mount. Secure with screw (9), two washers (10), and nut (11).
 - b. Install new grommet (12) in battery compartment. Route lead (8) through grommet into battery compartment.
 - c. Place lead (8) on screw (3) on terminal lugs (4) and secure with nut (1).
11. Coat tops of four battery terminal lugs with grease.

CAUTION

Battery cells can be damaged if the batteries are hooked up incorrectly. Make sure batteries are hooked up correctly.

12. push indrawer (13) and turn handle secure

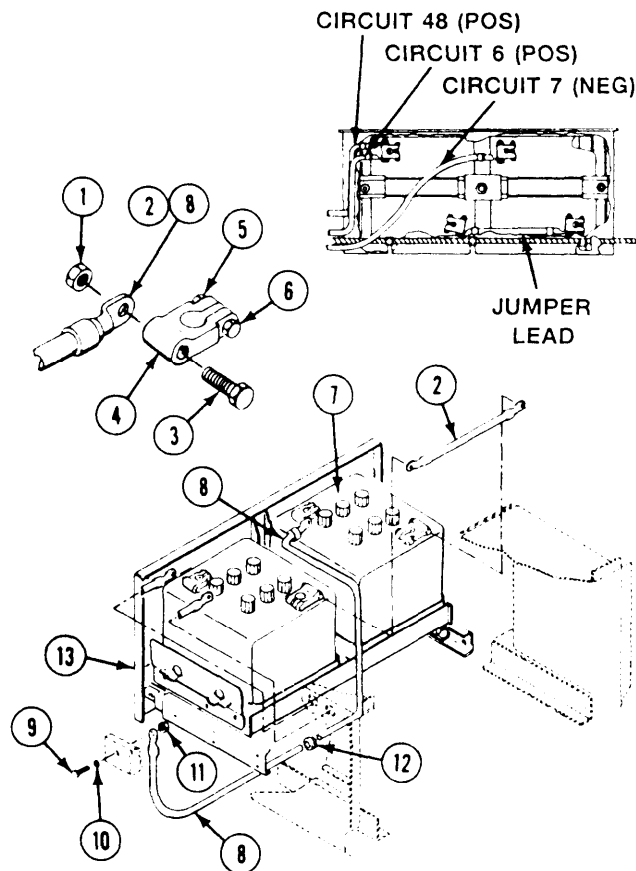

GO TO NEXT PAGE

FOLLOW-THROUGH STEPS

1. Turn MASTER SWITCH ON. Check BATT-GEN gage on instrument panel. Gage should read in BATT green or yellow zone (see your -10).
 2. Start engine (see your -10).
 3. Raise and lock ramp (see your -10).
 4. Stop/shutdown engine see your -10).
-

END OF TASK

REPLACE CIRCUIT 6 LEAD (ALL EXCEPT M577A2 AND M1068)

DESCRIPTION

This task covers: Remove (page 13-13). Clean, Inspect, and Repair (page 13-14).
Install (page 13-14).

INITIAL SETUP

Tools:

General Mechanics Tool Kit (Item 30, App D)
Battery Terminal Cleaner (Item 13, App D)
Multimeter (Item 43, App D)
Battery Terminal Puller (Item 46, App D)

Materials/Parts

Grommet (2)

Personnel Required:

Unit Mechanic

References:

See your -10

Equipment Conditions:

Engine stopped/shutdown (see your -10)
Carrier blocked (see your -10)
Ramp lowered (see your -10)
Battery ground lead disconnected (page 13-2)
Battery box cover removed (page 13-3)

REMOVE

WARNING



Gas from batteries can explode. Ventilate compartment before you disconnect or connect battery cables. Battery acid can burn or blind you. Do not get acid on your skin or eyes. ALWAYS disconnect ground lead (circuit 7) first and connect it last.

1. Remove nut (1), circuit 6 lead (2), and screw (3) from terminal lug (4).
2. Remove lead (2) and grommet (5) from battery box (6). Discard grommet.
3. On M113A2, M741A1, and M901A1 carriers, remove five clips (7) from cradles (8). Remove lead (2) from cradles.
4. Remove five screws (9) and cradles (8) from hull weldnuts.

5. On M106A2 and M125A2 carriers, remove one clip (1) from cradle (2). Remove two screws (3), washers (4), and clamps (5) from two hull weldnuts.
6. Remove eight nuts (6), washers (7), screws (8), and master switch panel (9) from distribution box (10).

NOTE

Nut (11) and screw (13) secure three leads circuits 2, 6, and 400, to the master switch bus bar, on all carriers covered by this task except M741A1. On M741A1 carriers the nut and screw secure two leads, circuits 6 and 400, to the bus bar.

7. Remove nut (11), lead (12), and screw (13) from master switch bus bar (14). Remove lead and grommet (15) from panel (9). Discard grommet.
8. Pull lead (12) from hull support channel. Remove lead from carrier.

WARNING

Battery posts and cables touched by metal objects can short circuit and bum you. Do not wear jewelry, necklaces, or watches when working on the electrical system. Keep tools away from posts, wires, and terminals.

CAUTION

Do not start vehicles while batteries are disconnected. Starting engine with outside power will damage electrical components in the regulator.

CLEAN, INSPECT, AND REPAIR

9. Clean lead terminals and mating surfaces with terminal cleaner.
10. Check leads. Replace worn leads and damaged connectors (page 14-3).

INSTALL

11. Route circuit 6 lead (12) through hull support channel.
12. Install new grommet (15) on lead (12). Install lead and grommet in master switch panel (9).

NOTE

Nut (11) and screw (13) secure three leads, circuits 2,6, and 400, to the master switch bus bar on all earners except M741A1. On M741A1 carrier the nut and screw secure two leads, 6 and 400. Be sure you secure all leads to the master switch bus bar when you install the screw (13) and nut (11).

13. Place lead (12) on master switch bus bar (14). Secure with screw (13) and nut (11).
14. Place panel (9) on distribution box (10). Secure with eight washers (7), screws (8), and nuts (6).

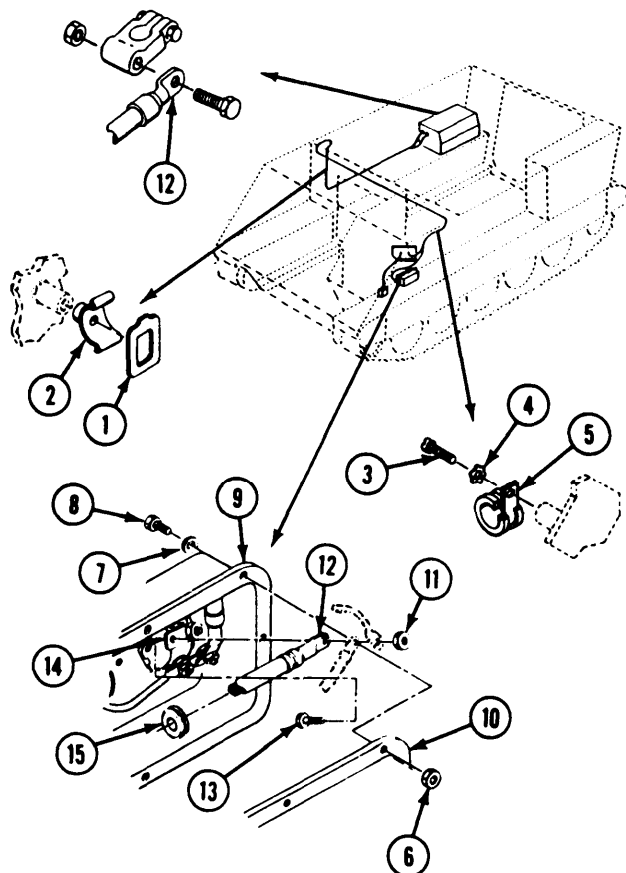

15. On M106A2 and M125A2 carriers, align two clamps (1) with weldnuts. Secure with two washers (2) and screws (3). Place lead (4) in cradle (5). Secure with clip (6).
16. on M113A2, M741A1, and M901A1 carriers, install five cradles (5) on hull weldnuts. Secure with five screws (7). Place lead (4) in five cradles and secure with clips (6).
17. Install new grommet (8) on lead (4). Install lead and grommet in battery box (9),
18. Install screw (10) and lead (4) on battery terminal lug (11). Secure with nut (12).

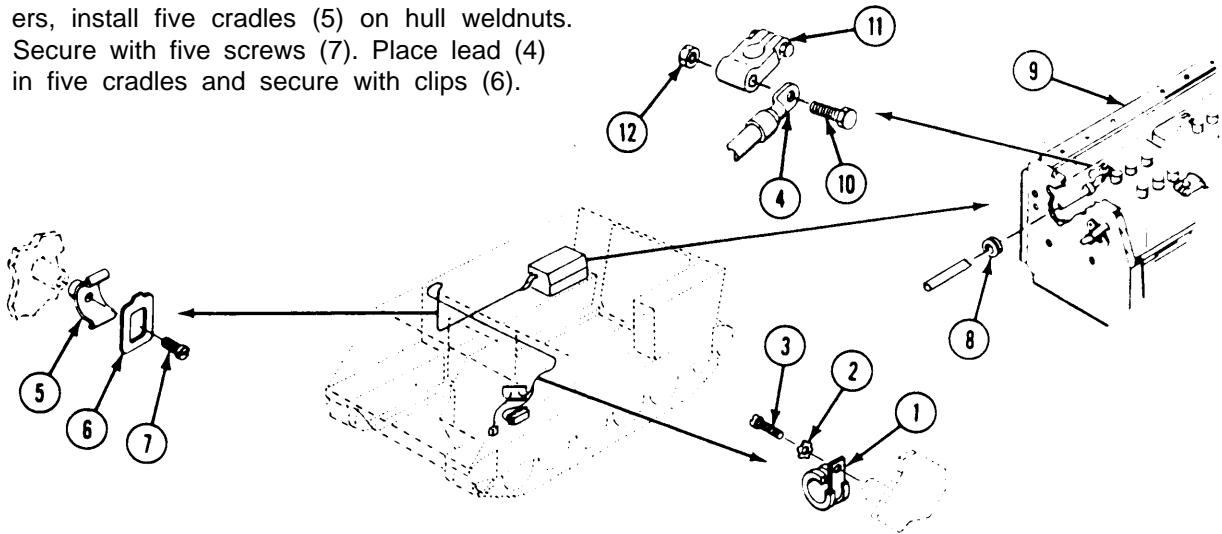

FOLLOW-THROUGH STEPS

1. Install battery box cover (page 13-3).
2. Connect battery ground lead (page 13-2).
3. Turn MASTER SWITCH ON (see your -10). Check that circuit 6 lead is installed correctly. MASTER SWITCH light should come on.
4. Raise and lock ramp (see your -10).
5. Stop/shutdown engine (see your -10).

END OF TASK

REPLACE BATTERY AND RETAINERS (ALL EXCEPT M106A2 AND M125A2)

DESCRIPTION

This task covers: Remove (page 13-16). Clean, Inspect, and Repair (page 13-17).
Install (page 13-17).

INITIAL SETUP

Tools:

General Mechanics Tool Kit (Item 30, App D)

Materials/parts

Epoxy Coating Kit (Item 15, App C)
Sodium Bicarbonate (Item 55, App C)

Personnel Required:

Unit Mechanic
Helper (H)

References:

See your -10
TM 9-6140-200-14

Equipment Conditions :

Engine stopped/shutdown (see your -10)
Carrier blocked (see your -10)
Ramp lowered (see your -10)
Battery ground lead disconnected (page 13-2)
Battery terminal lugs removed (page 13-10)

REMOVE

1. Remove bolt (1), washer (2), and clamp (3) from two retainers (4).
2. Remove two nuts (5), washers (6), and retainers (4) from two bolts (7).
3. Turn bolts (7) to align with slot in frame (8). Remove bolts from frame.



WARNING

Electrolyte and battery corrosion can cause injury to you. Wear safety goggles and gloves. If electrolyte or battery corrosion contacts the eyes, skin, or clothing,

flush immediately with large amounts of cold water. In case of eye or skin contact, see a doctor immediately.



WARNING

Battery is heavy and can cause injury if handled improperly. Be sure to have helper assist to remove battery. Battery weighs about 75 lb (34 kg).

CAUTION

Be careful. Do not hit side of carrier. You could crack the case. Set battery down gently onto a board. Have helper assist.

4. Remove batteries (9) from battery box (10). Lift battery by carrying handles built into each battery.

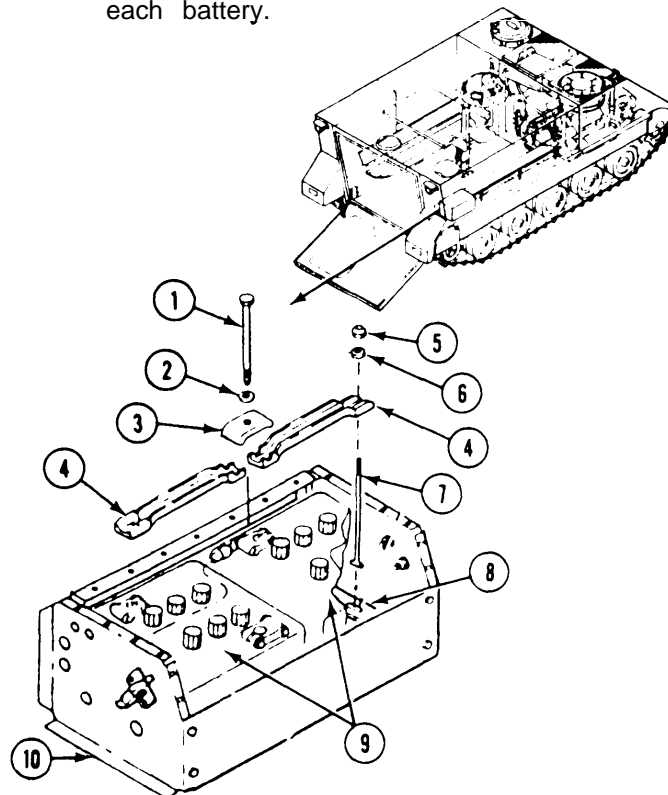

CLEAN, INSPECT, AND REPAIR



WARNING

Battery posts and cables touched by metal objects can short circuit and bum you. Do not wear jewelry, necklaces, or watches when operating on the electrical system. Keep tools away from posts, wires, and terminals.

5. Clean battery with nonmetallic brush dipped in mixture of sodium bicarbonate. After foaming stops, flush battery with clean water. Dry with clean cloth.
6. Clean retainers and parts by soaking in mixture of sodium bicarbonate. Dry parts and apply epoxy coating.
7. See TM 9-6140-200-14 to service batteries.

INSTALL



WARNING

Battery is heavy and can cause injury if handled improperly. Be sure to have helper assist to install battery. Battery weighs about 75 lb (34 kg).

8. Place batteries (1) in battery box (2).

CAUTION

Place batteries with positive (+) and neg-

9. Install two bolts (3) in slots of battery frame (4). Turn bolts to secure.
10. Install two retainers (5) on two bolts (3). Secure with two washers (6) and nuts (7).
11. Place clamp (8) on two retainers (5). Secure with washer (9) and bolt (10).

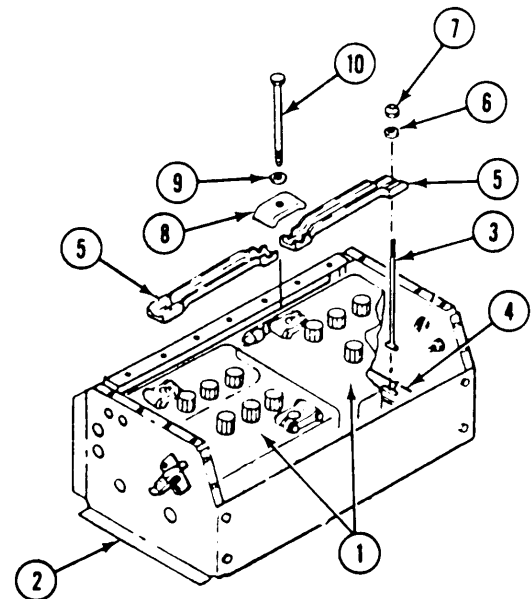
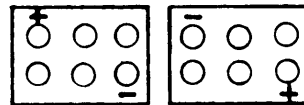

FOLLOW-THROUGH STEPS

1. Install battery terminal lugs (page 13-10).
2. Connect battery ground lead (page 13-2).
3. Turn MASTER SWITCH ON to check that batteries are installed correctly. Master switch light should come on (see your -10).
4. Raise and lock ramp (see your -10).
5. Stop/shutdown engine (see your -10).

END OF TASK

REPLACE BATTERIES AND RETAINERS (M106A2, M125A2, AND M1064 ONLY)

DESCRIPTION

This task covers: Remove (page 13-18). Clean, Inspect, and Repair (page 13-19).
Install (page 13-19).

INITIAL SETUP

Tools:

- General Mechanics Tool Kit (Item 30, App D)
- Battery terminal Cleaner (Item 13, App D)

Materials/Parts:

- Epoxy coating kit (Item 15, App C)
- Sodium bicarbonate (Item 55, App C)
- Wiping rag (Item 61, App C)

Personnel Required:

Unit Mechanic

Personnel Required: (cont):

Helper (H)

References:

See your -10
TM 9-6140-200-14

Equipment Conditions:

Engine stopped (see your -10)
Battery leads disconnected (page 13-2) and
terminal lugs removed (page 13-10)

CAUTION

Do not start carriers while batteries are disconnected. Starting engine with outside power while batteries are disconnected will damage electrical components in the regulator.

REMOVE

1. Remove bolt (1), washer (2), and clamp (3) from two retainers (4).
2. Remove two nuts (5), washers (6), and retainers (4) from two hooks (7). Remove hooks from frame (8).

WARNING

Electrolyte and battery corrosion can cause injury



you. Wear safety goggles and gloves. If electrolyte or battery corrosion contacts the eyes, skin, or clothing, flush with large amounts of cold water and see a doctor immediately.

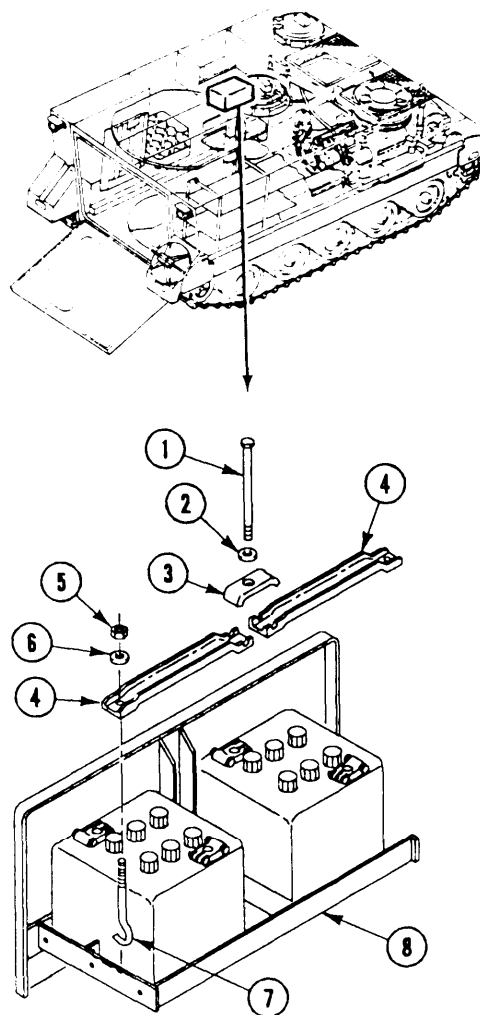

WARNING



Battery is heavy and can cause back injury if handled improperly. Be sure to have helper assist to remove battery. Battery weighs about 75 lb (34 kg).

CAUTION

Be careful. Do not hit side of carrier. You could crack the case. Set battery down gently on a board.

3. Remove batteries (1) from battery box (2). Lift battery by carrying handles built into each battery,

CLEAN, INSPECT, AND REPAIR

WARNING

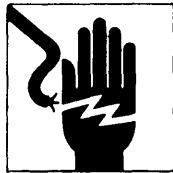

Battery posts and cables touched by metal objects can short circuit and burn you. Do not wear jewelry, necklaces, or watches when working on the electrical system. Keep tools away from posts, wires, and terminals.

4. Clean battery with nonmetallic brush dipped in mixture of sodium bicarbonate. After foaming stops, flush battery with clean water. Dry with clean cloth.
5. Clean retainers and parts by soaking in mixture of sodium bicarbonate. Dry parts and apply epoxy coating.
6. See TM 9-6140-200-14 to service batteries,

INSTALL

WARNING



Battery is heavy and can cause back injury if handled improperly. Be sure to have helper assist to install battery. Battery weighs about 75 lb (34 kg).

CAUTION

Place batteries with positive (+) and negative (-) terminals as shown in diagram. Damage to components will occur if batteries are hooked up wrong.

7. Place batteries (1) in battery box (2).
8. Place hooks (3) in battery frame (4).
9. Place two retainers (5) on two hooks (3). Secure with two washers (6) and nuts (7).
10. Place clamp (8) on two retainers (5). Secure with washer (9) and bolt (10).

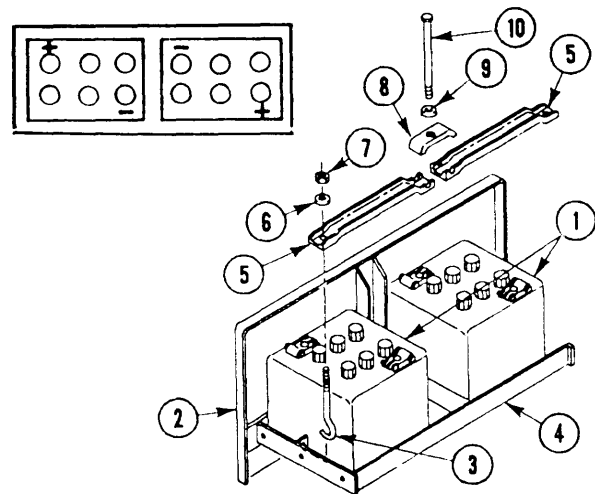

FOLLOW-THROUGH STEPS

1. Install terminal lugs (page 3-10) and connect battery leads (page 13-2),
2. Turn MASTER SWITCH ON to check that battery is installed correctly. Master switch light should come on (see your -10).
3. Start engine. Raise and lock ramp (see your -10).
4. Stop engine (see your -10).

END OF TASK

REPAIR BATTERY BOX COVER (M113A2, M901A1, M741A1, AND M1059 ONLY)

DESCRIPTION

This task covers: Remove (page 13-20). Clean, Inspect, and Repair (page 13-20).
Install (page 13-21).

INITIAL SETUP

Tools:

General Mechanics Tool Kit (Item 30, App D)

References:

See your -10

Materials/Parts:

Epoxy Coating Kit (Item 15, App C)
Sodium Bicarbonate (Item 55, App C)
Self-locking nut (4)

Equipment Conditions:

Engine stopped/shutdown (see your -10)
Ramp lowered (see your -10)
Battery box cover removed (page 13-3)

Personnel Required:

Unit Mechanic

REMOVE

1. Remove four locknuts (1) and screws (2) from battery box cover (3). Discard locknuts.
2. Remove support (4) and seal (5) from cover (3).

CLEAN, INSPECT, AND REPAIR

3. Clean cover by soaking in mixture of sodium bicarbonate and water. After foaming stops, flush with clean water and dry with clean cloth .
4. Inspect cover for dents and cracks. If damaged beyond repair, install new cover.
5. Inspect seal for cuts, tears and loss of resilience. If seal is unserviceable, install new seal.

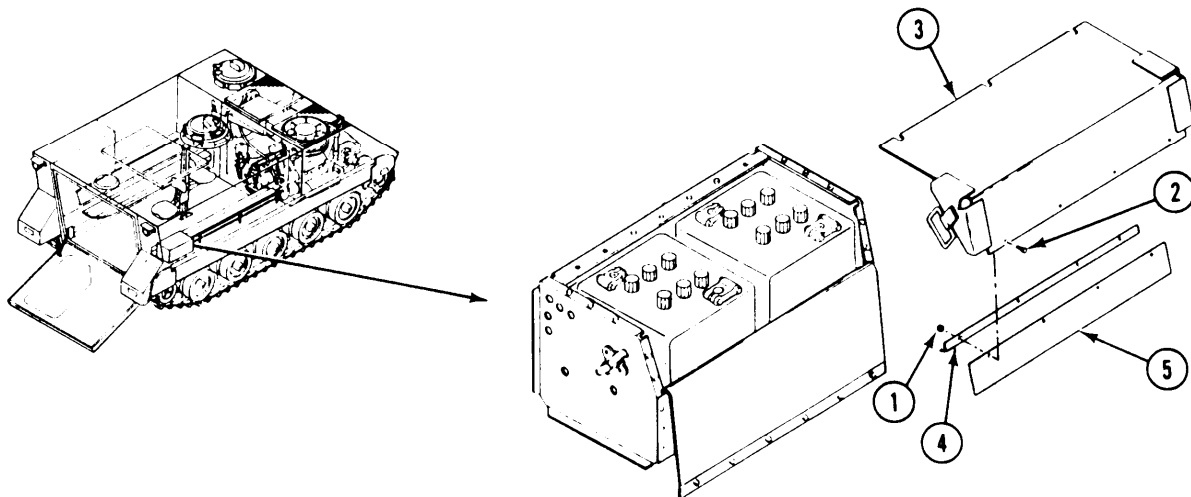

INSTALL

6. Apply epoxy coating to battery box cover (1).
7. Place seal (2) and support (3) on cover (1).
8. Secure with four screws (4) and new lock-nuts (5).

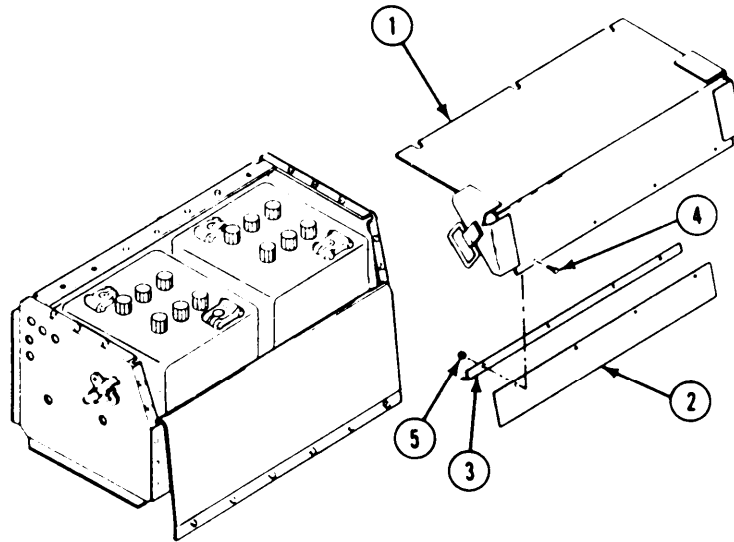

FOLLOW-THROUGH STEPS

1. Install battery box cover (page 13-3).
2. Start engine, Raise and lock ramp (see your -10).
3. Stop/shutdown engine see your -10).

END OF TASK

REPAIR BATTERY BOX (ALL EXCEPT M125A2 AND M106A2)

DESCRIPTION

This task covers: Remove (page 13-22). Clean, Inspect, and Repair (page 13-23).
Install (page 13-23).

INITIAL SETUP

Tools:

General Mechanics Tool Kit (Item 30, App D)
Socket Wrench Set (Item 89, App D)
Torque Wrench (Item 94, App D)

Materials/Parts:

Epoxy coating kit (Item 15, App C)
Sodium bicarbonate (Item 55, App C)
Self-locking nut (3)
Self-locking nut (4)

Personnel Required:

Unit Mechanic

References:

See your -10

Equipment Conditions:

Engine stopped/shutdown (see your - 10)
Battery box cover and leads removed (page 13-3)
Batteries and retainers removed (page 13-16)
Ramp lowered (see your -10)

REMOVE

NOTE

Repair of the M577A2 battery box is limited to replacement of the channel divider and battery box cover rubber bumpers. The steps below are for all other carriers except those indicated by the task title.

1. Remove four lock nuts (1), washers (2), screws (3), and two latches (4) from side of battery box (5). Discard locknuts.
2. Remove two screws (16), washers (71, and channel divider (8) from battery frame (9).
3. Remove four screws (10), eight washers (11), and battery frame (9) from battery box (5). remove four resilient mounts (12) from frame.
4. Remove three locknuts (13), washers (14).
5. If necessary, remove rubber bumpers (18) from battery box (5). discard locknuts

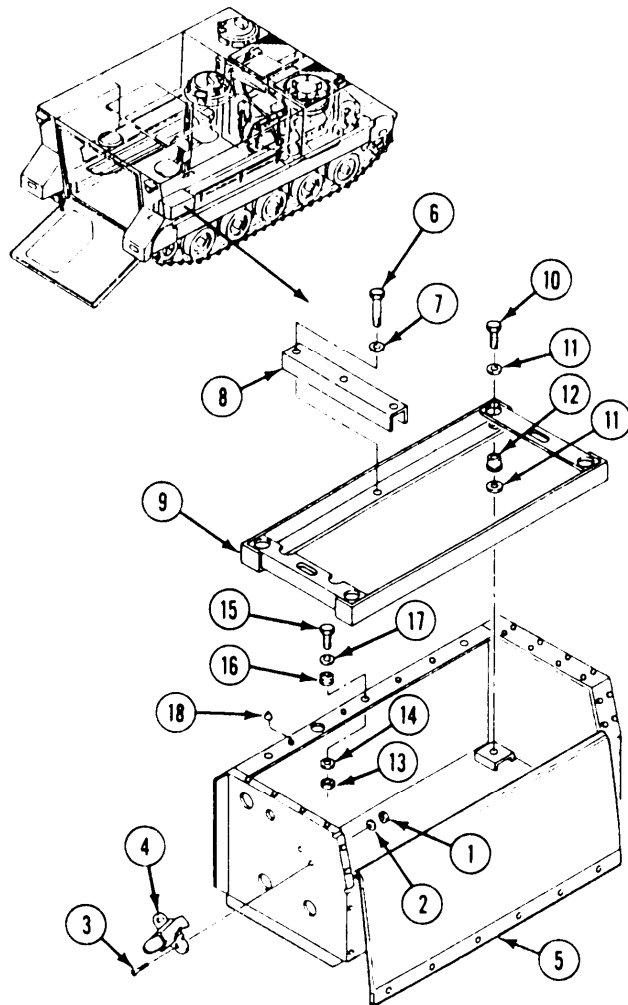

CLEAN, INSPECT, AND REPAIR

6. Inspect resilient mounts, bumpers, and grommets for cuts, cracks, tears, and loss of resilience. If parts are hard, brittle, cut cracked, or torn, install new parts.
7. Clean battery box with brush dipped in mixture of sodium bicarbonate. After foaming stops, flush with clean water and dry with clean cloth.
8. Inspect battery box for dents and cracks. If damaged beyond repair, notify direct support maintenance.
9. Inspect frame and divider channel for dents and cracks. If damaged beyond repair, install new part.

14. Place channel divider (12) in battery frame (9). Secure with two washers (13) and screws (14). Tighten screws to 84–120 lb-in (11–14 NŹm) torque. Use torque wrench and socket.
15. Place two latches (15) on side of battery box (1). Secure with four screws (16), washers (17), and new locknuts (18).

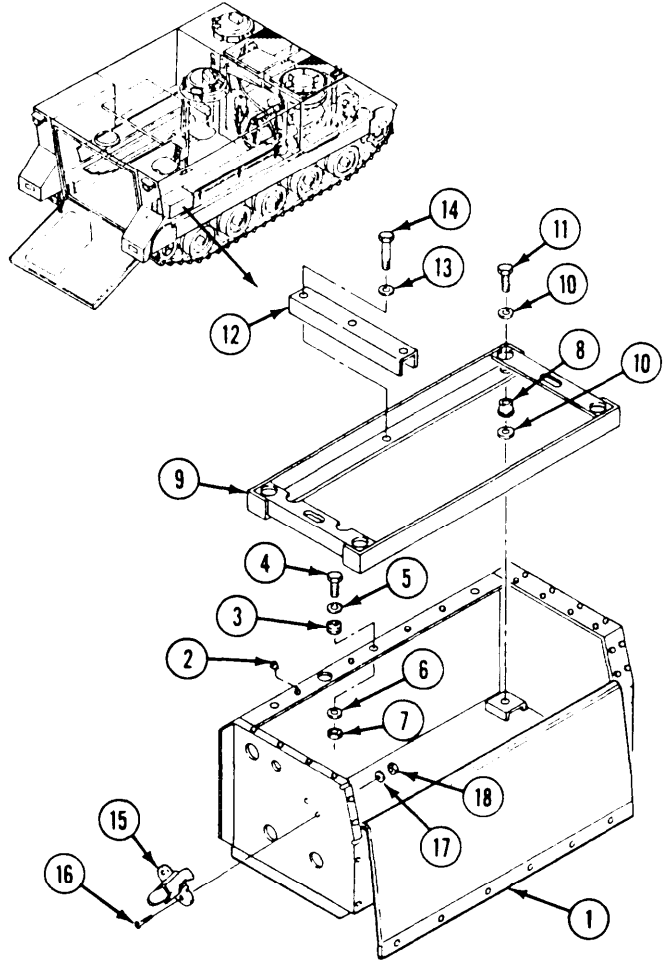

INSTALL

10. Apply epoxy coating to battery box (1).
11. If removed, install battery box cover rubber bumpers (2) on battery box (1).
12. Install three grommets (3) on battery box (1). Secure with three screws (4), washers (5), washers (6), and new locknuts (7).
13. Install four resilient mounts (8) in frame (9). Place frame in battery box (1) and secure with eight washers (10) and four screws (11). Tighten screws to 120–192 lb-in (113–22 NŹm) torque. use torque wrench and socket.

FOLLOW-THROUGH STEPS

1. Install batteries and retainers (page 13-16).
2. Install battery leads and box covers (page 13-3).
3. Start engine. Raise and lock ramp (see your –10).
4. Stop/shutdown engine (see your –10).

END OF TASK

REPAIR BATTERY DRAWER (M106A2, M125A2, AND M1064 ONLY)

DESCRIPTION

This task covers: Remove (page 13-24). Clean, Inspect, and Repair (page 13-25).
Install (page 13-25).

INITIAL SETUP

Tools:

General Mechanics Tool Kit (Item 30, App D)

Personnel Required:

Unit Mechanic

Materials/Parts:

- Epoxy coating kit (Item 15, App C)
- Grease (Item 18, App C)
- Sodium bicarbonate (Item 55, App C)
- Self-locking nut (18)
- Self-locking nut (8)
- Self-locking nut (4)
- Self-locking nut (2)
- Self-locking nut

References:

See your -10

Equipment Conditions:

- Engine stopped/shutdown (see your -10)
- Carrier blocked (see your -10)
- Battery leads removed (page 13-10)
- Batteries and retainers removed (page 13-18)

REMOVE

1. Lower the left crew seat backrest, turn handle (1) and pull drawer (2) out.
2. Remove eight locknuts (3), washers (4), screws (5), and battery drawer (6) from two angles (7). Discard locknuts.
3. Extend two slide assemblies (8) to stops. Remove eight locknuts (9), washers (10), screws (11), and two angles (7) from slide assemblies. Discard locknuts.
4. Extend two slide assemblies (8) to stops. Remove 10 locknuts (12), washers (13), screws (14), and slide assemblies from hull mounts. Discard locknuts.

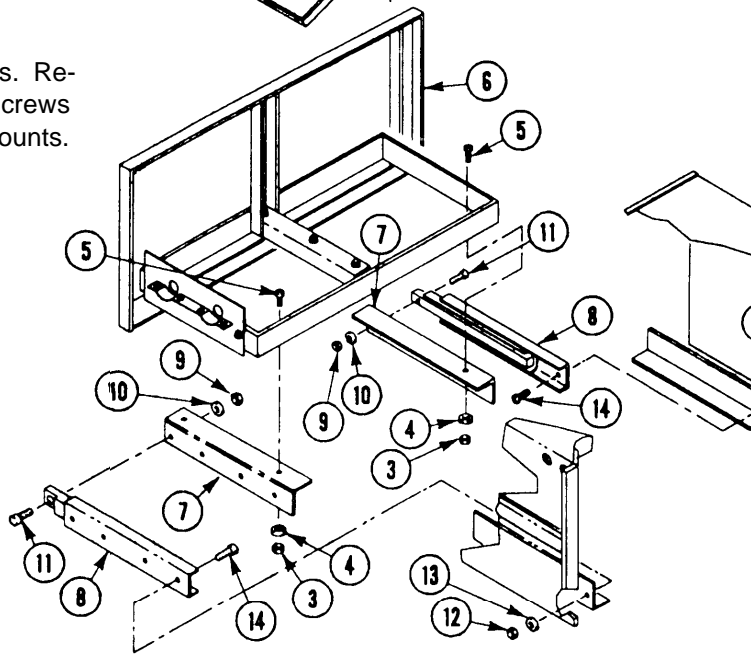
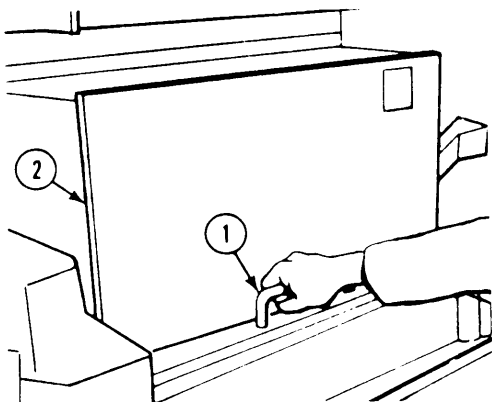
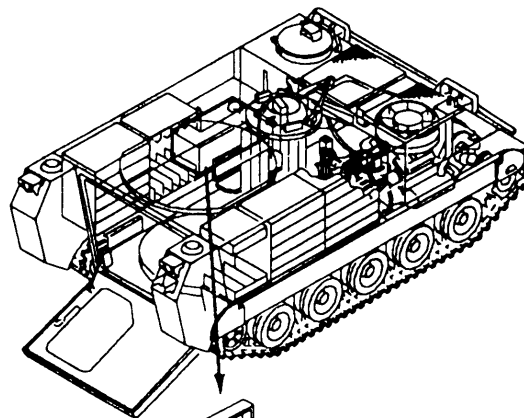

5. Remove three locknuts (1), washers (2), screws (3), and plate (4) from side of battery drawer (5). Discard locknuts.
6. Remove two locknuts (6), washers (7), screws (8), and channel divider (9) from battery drawer (5). Discard locknuts.
7. Remove locknut (10), cam (11), handle (12), and washer (13) from battery drawer (5). Remove key (14) from handle. Discard locknut.
8. If needed, remove locknut (15), screw (16), and wear plate (17) from hull mount.
9. If needed, remove two rubber bumpers (18) from front of battery drawer (5).

17. Place channel divider (9) in battery drawer (5). Secure with two screws (8), washers (7), and new locknuts (6).
18. Place plate (4) on side of drawer (5). Secure with three screws (3), washers (2), and new locknuts (1) .

CLEAN, INSPECT, AND REPAIR

10. Inspect slide assemblies. If the slide binds or has damaged stops, install a new slide.
11. Clean drawer and parts by soaking in a solution of sodium bicarbonate. After foaming stops, flush with clean water and dry with clean cloth.
12. Inspect battery drawer for dents and cracks. If damaged beyond repair, install new drawer.

INSTALL

13. Apply epoxy coating to inside surface of battery drawer (5).
14. If removed, install rubber bumpers (18) in battery drawer (5).
15. If removed, place wear plate (17) on hull mount. Secure with screw (16) and new locknut (15).
16. Install washer (13) and handle (12) in battery drawer (5). Insert key (14) in handle and install cam (11). Secure with new locknut (10).

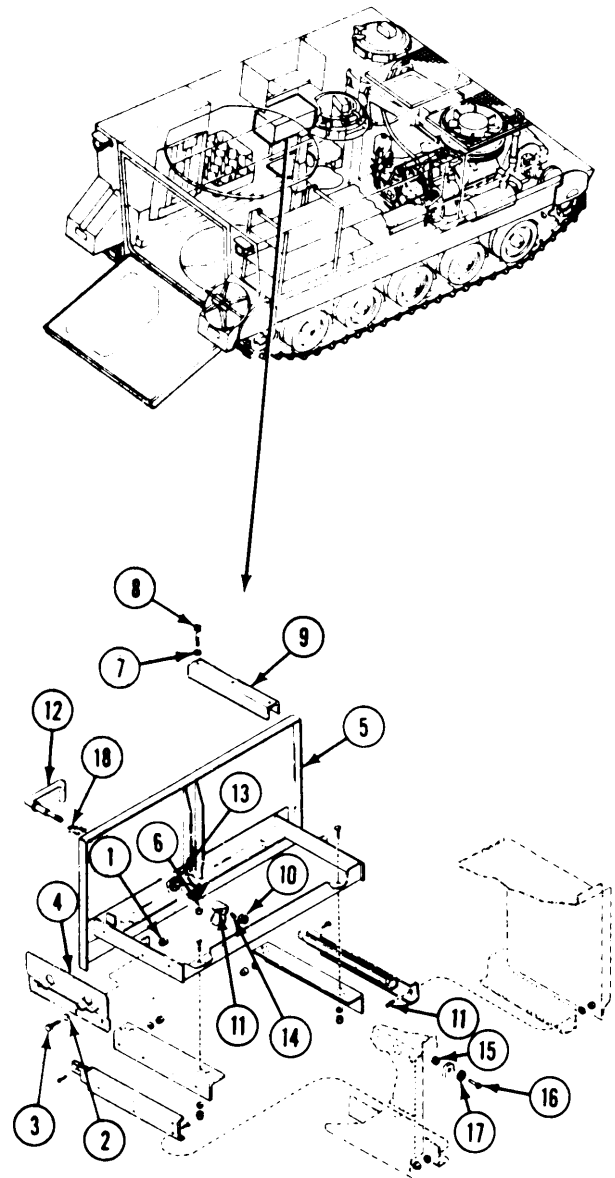

19. Coat all bearing surfaces of two slide assemblies (1) with grease.
20. Place two slide assemblies (1) on hull mounts. Extend slide stops. Secure with 10 screws (2), washers (3), and new locknuts (4).
21. Extend two slide assemblies (1) to stops. Align two angles (5) with holes in slides. Secure with eight screws (6), washers (7), and new locknuts (8).
22. Align battery drawer (9) with holes in two angles (5). Secure with eight screws (10), washers (11), and new locknuts (12).
23. Turn handle (13) on drawer (9) to secure and raise left crew seat backrest.

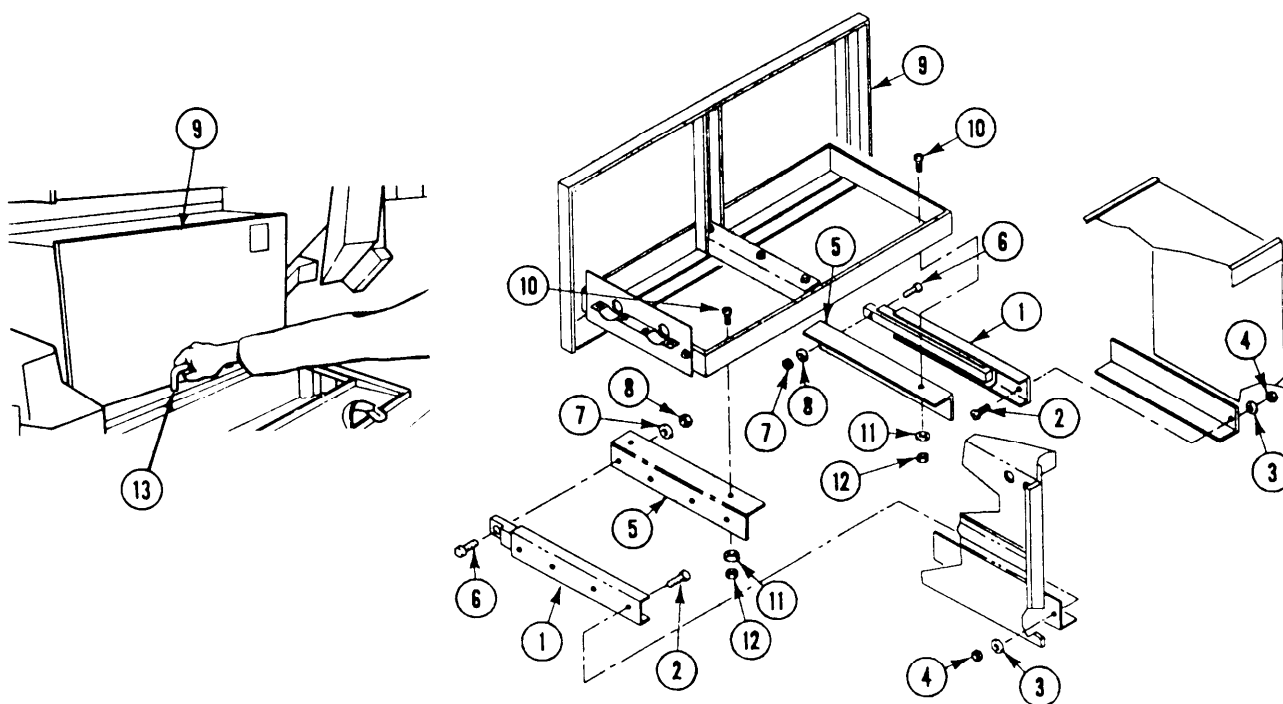

FOLLOW-THROUGH STEPS

1. Install batteries and retainers (page 13-18).
2. Install battery leads (page 13-10).
3. Raise and lock ramp (see your -10).
4. Stop engine (see your -10).

END OF TASK

REPLACE BATTERY TO RADIO HARNESS (M1059, M901A1, AND M113A2 ONLY)

DESCRIPTION

This task covers: Remove (page 13-27). Install (page 13-29).

INITIAL SETUP

Tools:

General Mechanics Tool Kit (Item 30, App D)

References:

See your -10

Materials/Parts:

12 Ft. of suitable rope
Self-locking nut (8)

Equipment Conditions:

Engine stopped (see your -10)
Carrier blocked (see your -10)
Battery ground lead disconnected (page 13-2)
Personnel heater removed (page 29-51)

Personnel Required:

Unit Mechanic

REMOVE

1. Remove nut (1), screw (2), circuit 48 harness (3), and circuit 6 lead (4) from battery terminal (5).

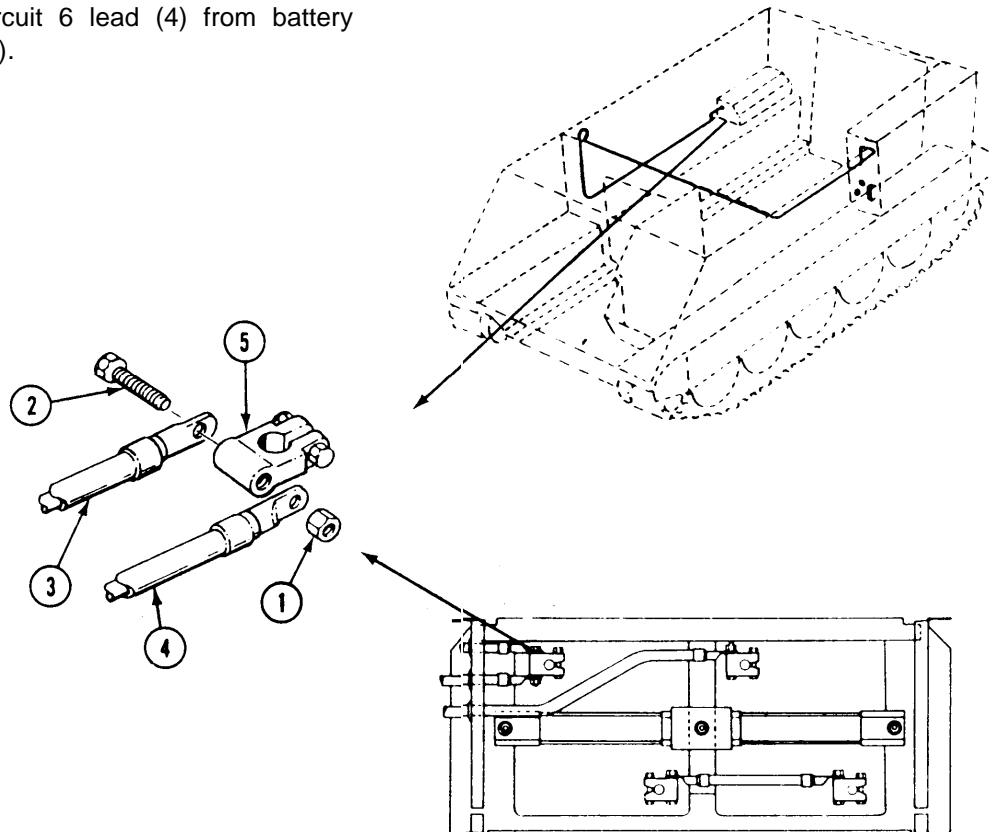

GO TO NEXT PAGE

2. Remove 10 clips (1) that secure circuit 48 harness (2) to 10 cradles (3).
3. Remove screw (4), clamp (5), and harness (2) from weldnut (6).
4. Remote cap assembly (7) from receptacle (8).

5. Remove screw (9), two lockwashers (10), clamp (11), two ground leads (12), and capacitor (13) from weldnut (14). Discard lockwashers.
6. Remove eight locknuts (15), screws (16), and two receptacles (8) from bracket (17). Discard locknuts.

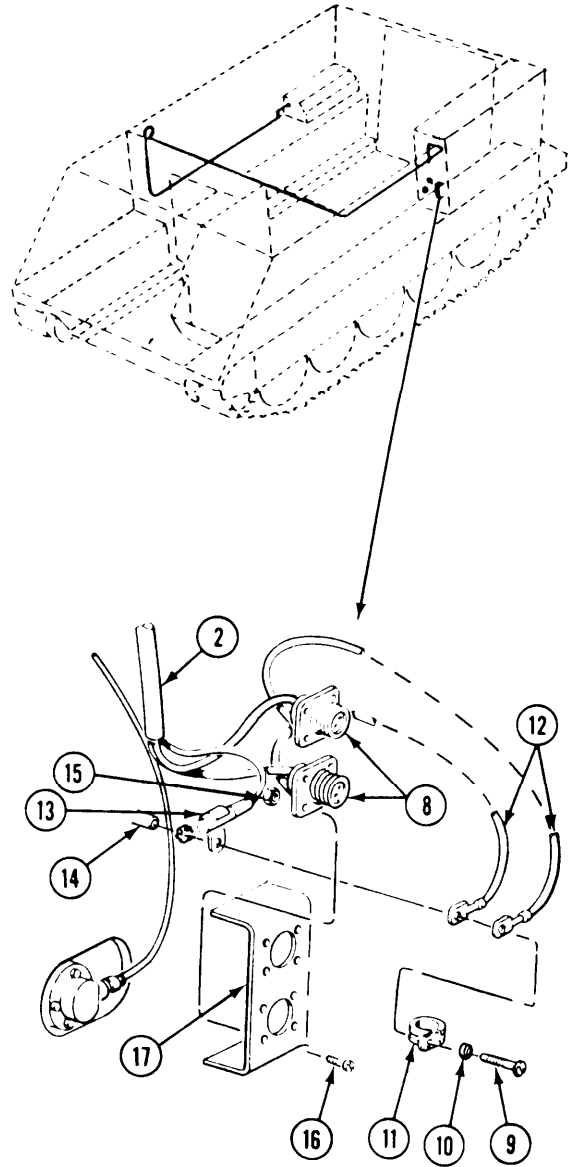
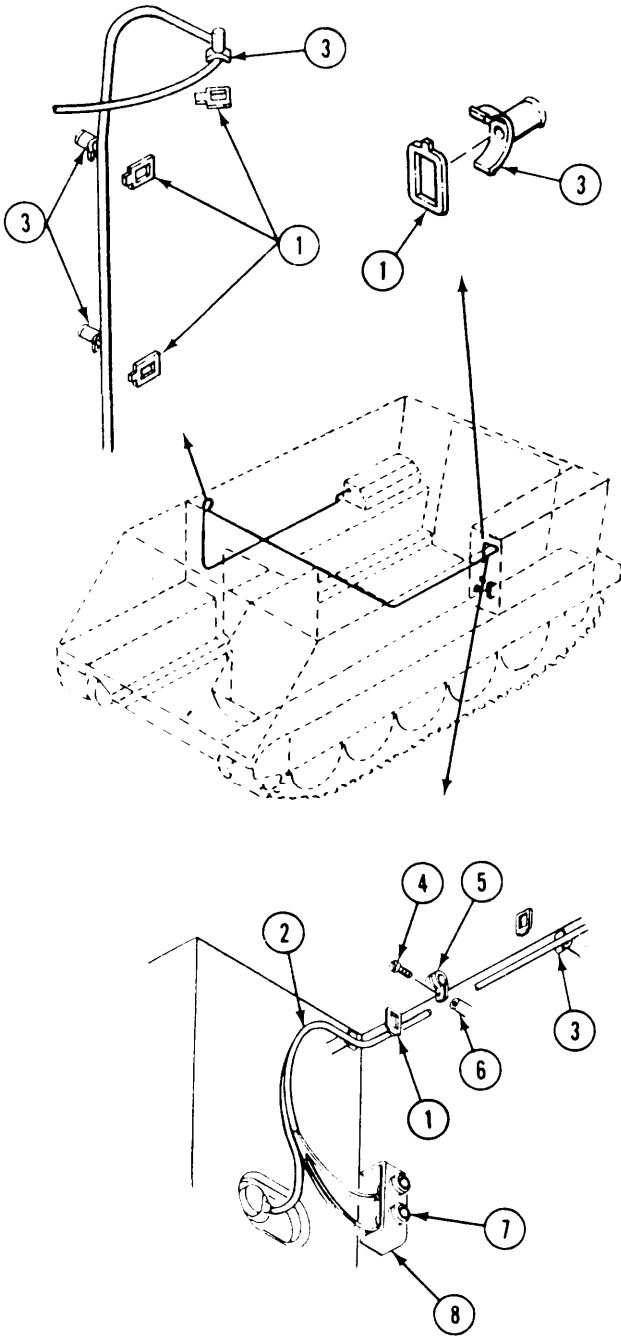

7. Attach a 12 foot (3.7 meter) rope (1) to the battery end of circuit 48 lead (2). Pull harness through the transverse beam from the receptacle end.
8. Do not pull rope out of transverse beam, Leave some rope hanging out of beam at right side of earner. Untie rope from harness (2).

INSTALL

9. Tie rope (1), retained in transverse beam, to circuit 48 harness (2) at battery end.
10. Pull rope (1) and harness (2) through the transverse beam until harness can be grasped at the right side of carrier.
11. Pull harness (2) to the battery box on right side of earner.

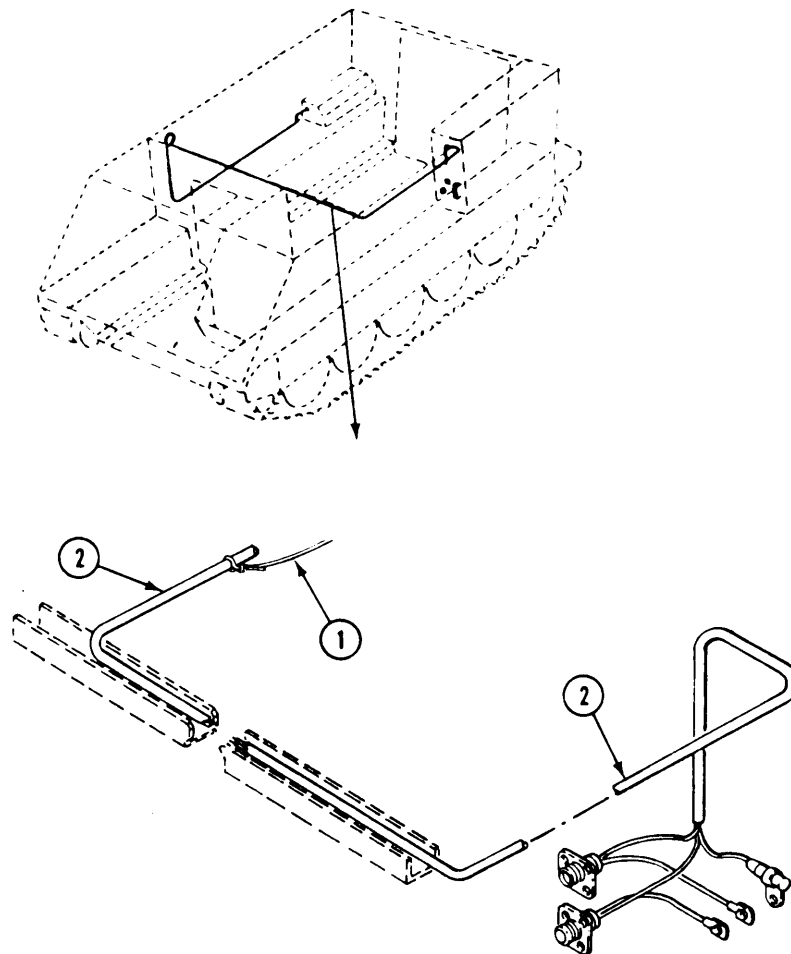

GO TO NEXT PAGE

- 12. Install two receptacles (1) on bracket (2). Secure with eight screws (3) and new locknuts (4).
- 13. Install two ground leads (5), one capacitor (6), and circuit 48 harness (7) on weldnut (8). Secure with screw (9), two new lockwashers (10), and one clamp (11).

- 14. Install cap assembly (12) on receptacle (1).
- 15. Secure clamp (13) and harness (7) to weldnut (14) with screw (15).
- 16. Secure circuit 48 harness (7) to 10 cradles (16) with 10 clips (17).

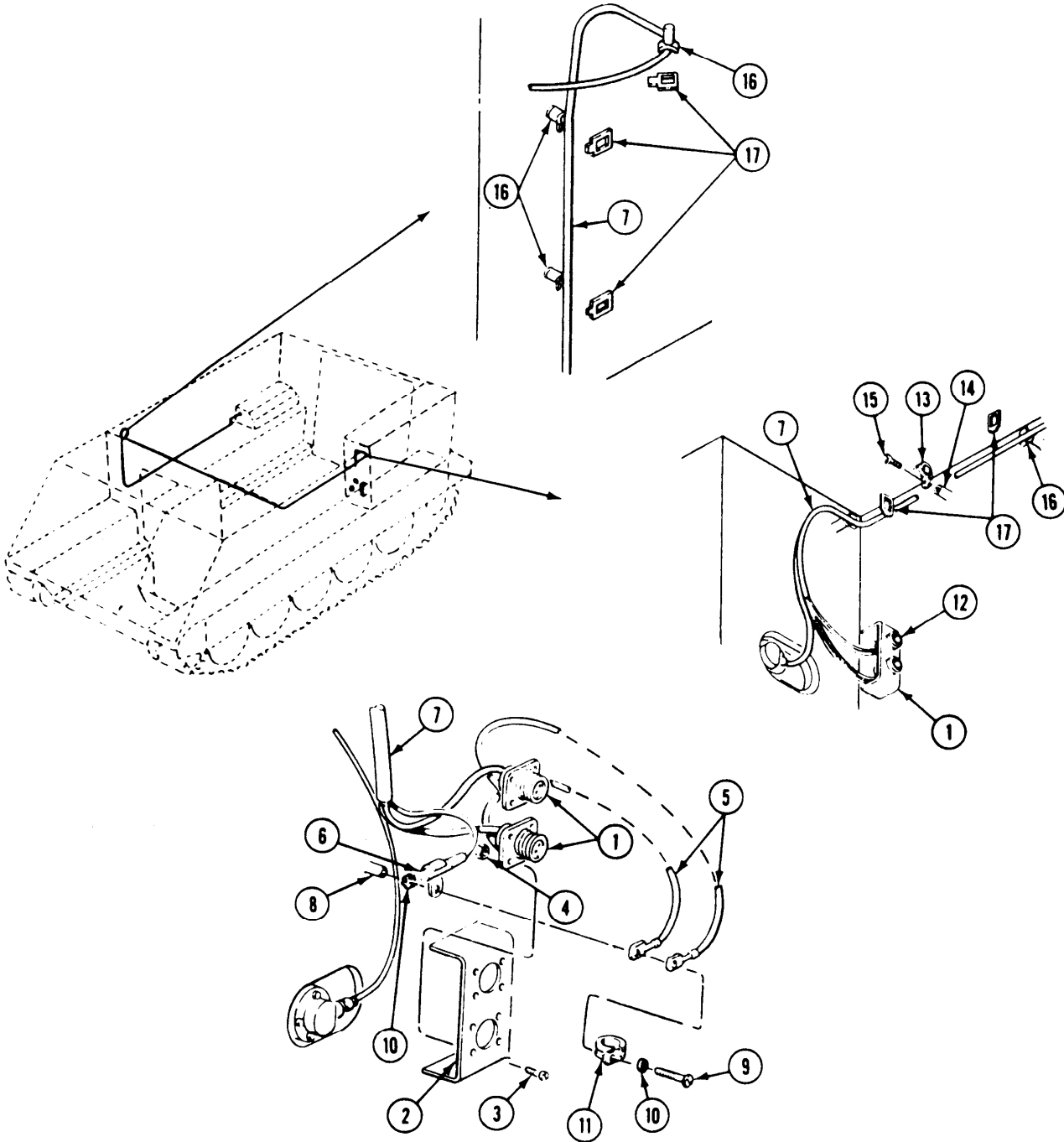

17. Install harness (1) and circuit 6 harness (2) on battery terminal (3). Secure with screw (4) and nut (5).

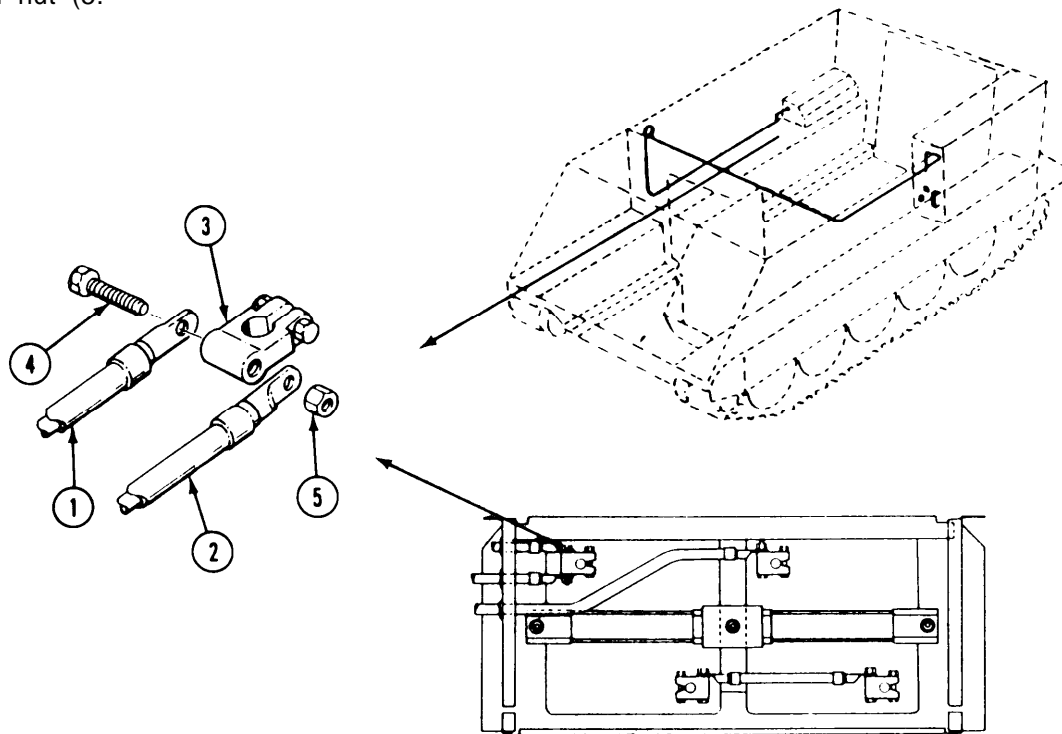

FOLLOW-THROUGH STEPS

1. Connect battery ground lead (page 13-2). 2. Install personnel heater (page 29-51).
-

END OF TASK

REPLACE BATTERY DRAWER INSULATION AND HEAT EXCHANGER (M106A2, M125A2, AND M1064 ONLY)

DESCRIPTION

This task covers: Remove (page 13-32). Clean, Inspect, and Repair (page 13-33).
Install (page 13-33).

INITIAL SETUP

Tools:

General Mechanics Tool Kit (Item 30, App D)

Materials/Parts:

Sealing compound (Item 52, App C)
Sodium bicarbonate (Item 55, App C)

Personnel Required:

Unit Mechanic

References:

See your -10

Equipment Conditions:

Engine stopped/shutdown (see your -10)
Carrier blocked (see your -10)
Ramp lowered (see your -10)
Batteries removed (page 13-18)
Carrier cooling system drained (page 8-3)
Coolant heater system drained (page 32-10)

REMOVE

1. Remove four nuts (1), washers (2), screws (3), and two brackets (4) from battery drawer (5).
2. Loosen four clamps (6). Remove two hoses (7) from heat exchanger (8) and two elbows (9). Remove clamps from hoses.
3. Remove battery drawer (page 13-24).
4. Remove heat exchanger (8) from battery drawer (5).
5. If damaged, remove top insulation sheet (10), bottom insulation sheet (11), rear insulation sheet (12), right insulation sheet (13), and left insulation sheet (14) from battery drawer shield (15).

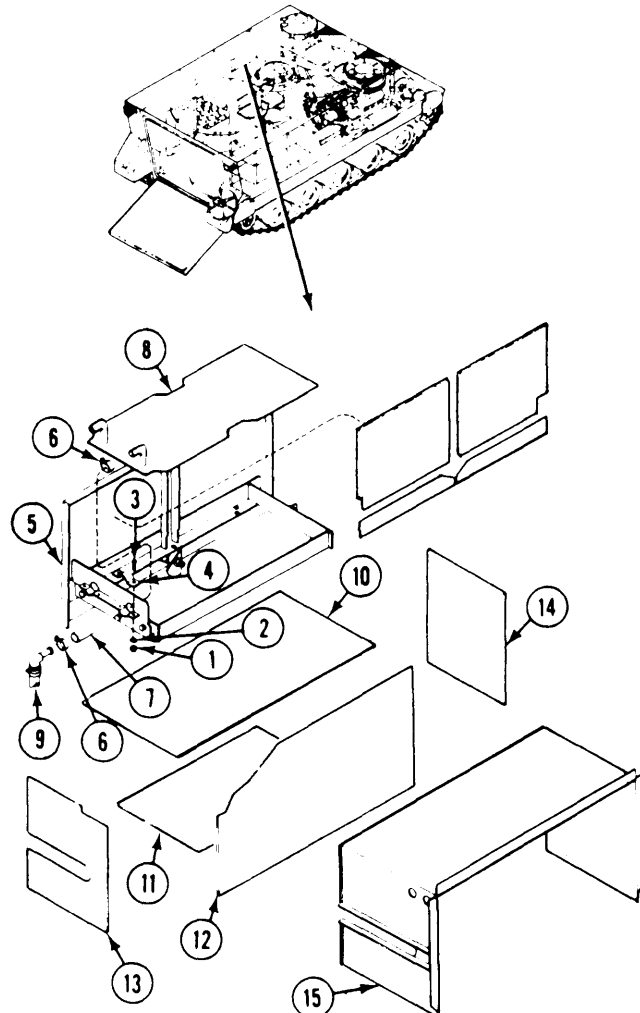

6. If damaged, remove two insulation sheets (1) and two insulation strips (2) from battery drawer (3).

CLEAN, INSPECT, AND REPAIR

7. Clean heat exchanger plate with brush dipped in mixture of sodium bicarbonate. After foaming stops, flush with clean water and dry.
8. Check heat exchanger. Replace bent or cracked heat exchanger.
9. Check insulation. Replace loose, missing, or damaged strip or sheets.

INSTALL

10. Apply adhesive on insulation sheets. Wait 10-20 seconds until adhesive becomes tacky.
11. If removed, install two insulation strips (2) and two insulation sheets (1) on battery drawer (3).
12. If removed, install left insulation sheet (4), right insulation sheet (5), rear insulation sheet (6), bottom insulation sheet (7), and top insulation sheet (8) in battery drawer shield (9).
13. Place two clamps (10) on heat exchanger (11). Install heat exchanger in battery drawer (3).

14. Install battery drawer (page 13-23).
15. Place two clamps (10) on two elbows (12). Install two hoses (13) on two elbows (12) and heat exchanger (11). Secure with four clamps.
16. Place two brackets (14) on battery drawer (3). Secure with four screws (15), washers (1), and nuts (2).

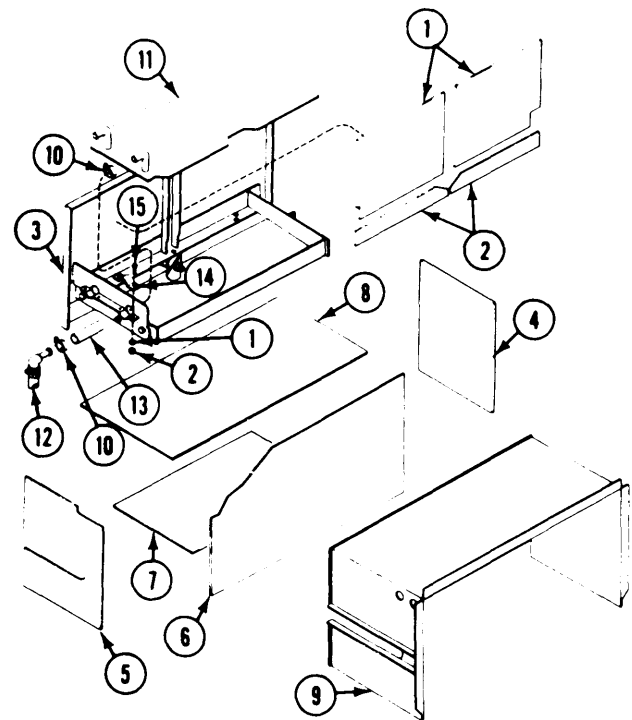

GO TO NEXT PAGE

FOLLOW-THROUGH STEPS

1. Install batteries (page 13-18).
 2. Fill carrier cooling system (page 8-5).
 3. Fill coolant heater system (page 32-10).
 4. Start coolant heater (see your -10). Check heat exchanger for leaks. Turn heater off.
 5. Raise and lock ramp (see your -10).
 6. Stop/shutdown engine (see your -10).
-

END OF TASK

REPLACE BATTERY BOX INSULATION AND HEAT EXCHANGER (M577A2 AND M1068 ONLY)

DESCRIPTION

This task covers: Remove (page 13-35). Clean, Inspect, and Repair (page 13-36).
Install (page 13-36).

INITIAL SETUP

Tools:

General Mechanics Tool Kit (Item 30, App D)

References:

See your -10

Materials/Parts:

Sealing Compound (Item 52, App C)
Sodium bicarbonate (Item 55, App C)
Grommet (2)

Equipment Conditions:

Engine stopped/shutdown (see your -10)
Carrier blocked (see your -10)
Ramp lowered (see your -10)
Carrier cooling system drained (page 8-3)
Coolant heater system drained (page 32-10)
Batteries removed (page 13-16)

Personnel Required:

Unit Mechanic

REMOVE

1. Loosen four clamps (1). Remove two hoses (2) from two elbows (3). Remove two elbows from two short hoses (4). Remove clamps.
2. Loosen two clamps (5) on heat exchanger (6). Remove hoses (4) from heat exchanger.
3. Remove heat exchanger (6) and two grommets (7) from battery box (8). Discard grommets.
4. If damaged, remove insulation sheet (9) from battery box cover (10).

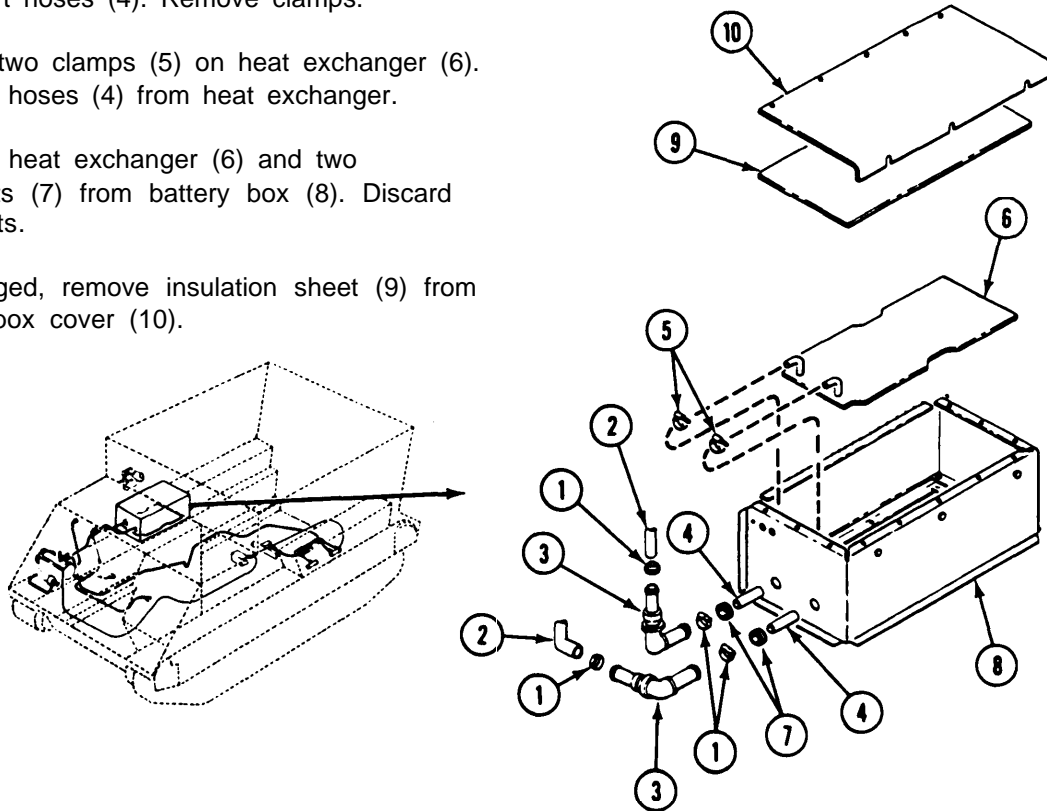

GO TO NEXT PAGE

5. If damaged, remove front insulation sheet (1), rear insulation sheet (2), right insulation sheet (3), left insulation sheet (4), and bottom insulation sheet (5) from battery box (6).

CLEAN, INSPECT, AND REPAIR

6. Clean heat exchanger plate with brush dipped in mixture of sodium bicarbonate and water. After foaming stops, flush with clean water and dry.
7. Check heat exchanger. Replace bent or cracked heat exchanger.
8. Check insulation. Replace loose, missing, or damaged strip or sheets.

INSTALL

9. Apply adhesive on insulation sheets. Wait 10-20 seconds until adhesive becomes tacky.
10. If removed, install bottom insulation sheet (5), left insulation sheet (4), right insulation sheet (3), rear insulation sheet (2), and front insulation sheet (1) in battery box (6).
11. If removed, install insulation sheet (7) on battery box cover (8).
12. Install two new grommets (9) in battery box (6).

13. Place two clamps (10) on heat exchanger (11). Install heat exchanger in battery box (6).
14. Install two short hoses (12) on heat exchanger (11). Secure with two clamps (10).
15. Place four clamps (13) on two elbows (14). Install elbows in hoses (12). Install hoses (15) on elbows. Secure all hoses with clamps (13).

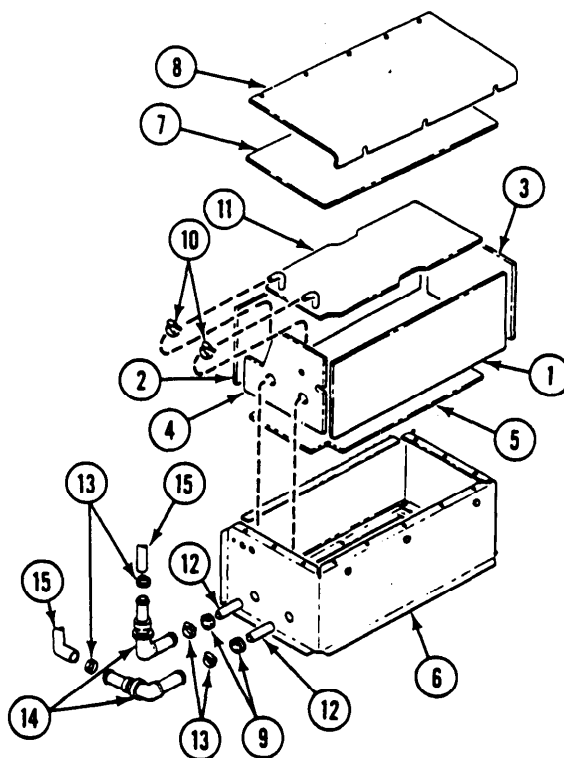

FOLLOW-THROUGH STEPS

1. Fill carrier cooling system (page 8-5).
2. Fill coolant heater system (page 32-10).
3. Start coolant heater (see your -10). Check for leaks.
4. Raise and lock ramp (see your -10).
5. Turn MASTER SWITCH OFF (see your -10).
6. Install batteries (page 13-16)

END OF TASK

REPLACE BATTERY BOX INSULATION AND HEAT EXCHANGER (M113A2, M741A1, M901A1, AND M1059 ONLY)

DESCRIPTION

This task covers: Remove (page 13-37). Clean, Inspect, and Repair (page 13-38).
Install (page 13-38).

INITIAL SETUP

Tools:

General Mechanics Tool Kit (Item 30, App D)

References:

See your -10

Materials/Parts:

Sealing compound (Item 52, App C)
Sodium Bicarbonate (Item 55, App C)
Grommet (2)

Equipment Conditions:

Engine stopped/shutdown (see your -10)
Carrier blocked (see your -10)
Ramp lowered (see your -10)
Batteries removed (page 13-18)
Carrier cooling system drained (page 8-3)
Coolant heater system drained (page 32-10)

Personnel Required:

Unit Mechanic

REMOVE

- Loosen two clamps (1) on two hoses (2). Remove hoses from heat exchanger (3). Remove clamps from hoses.
- On M741A1 carriers, loosen six clamps (1). Remove two hoses (2) from two elbows (4). Remove two elbows from two short hoses (5). Remove short hoses and clamps from heat exchanger (3).
- Remove heat exchanger (3) from battery box (6). Remove clamps from heat exchanger.
- Remove two grommets (7) from battery box (6). Discard grommets.

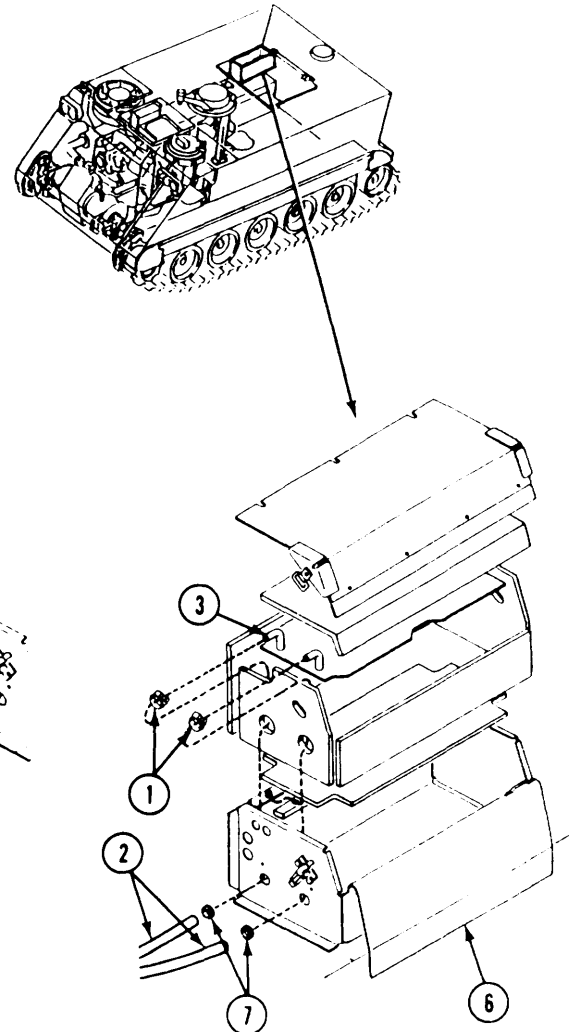
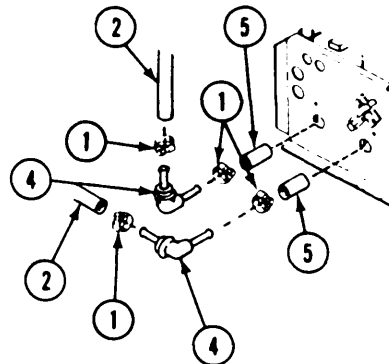

GO TO NEXT PAGE

5. If damaged, remove insulation sheet (1) from battery box cover (2).
6. If damaged, remove insulation strip (3), front insulation sheet (4), rear insulation sheet (5), right insulation sheet (6), left insulation sheet (7), and bottom insulation sheet (8) from battery box (9).

12. If removed, install insulation sheet (1) on battery box cover (2).
13. Install two new grommets (10) in battery box (9).
14. Install two clamps (11) on heat exchanger (12). Install heat exchanger in battery box (9).

CLEAN, INSPECT, AND REPAIR

7. Clean heat exchanger plate with brush dipped in mixture of sodium bicarbonate. After foaming stops, flush with clean water and dry.
8. Check heat exchanger. Replace bent or cracked heat exchanger.
9. Check insulation. Replace loose, missing, or damaged strip or sheets.

15. Install two hoses (13) on heat exchanger (12). Secure with two clamps (11).
16. On M741A1 carriers, install two short hoses (14) on heat exchanger (12). Secure with two clamps (11). Install two elbows (15) in hoses. Secure with two clamps (11). Place two clamps (11) on two hoses (13). Install hoses on elbows (15). Secure with clamps (11).

INSTALL

10. Apply sealing compound on insulation sheets. Wait 10–20 seconds until sealing compound becomes tacky.
11. If removed, install bottom insulation sheet (8), left insulation sheet (7), right insulation sheet (6), rear insulation sheet (5), front insulation sheet (4), and insulation strip (3) in battery box (9).

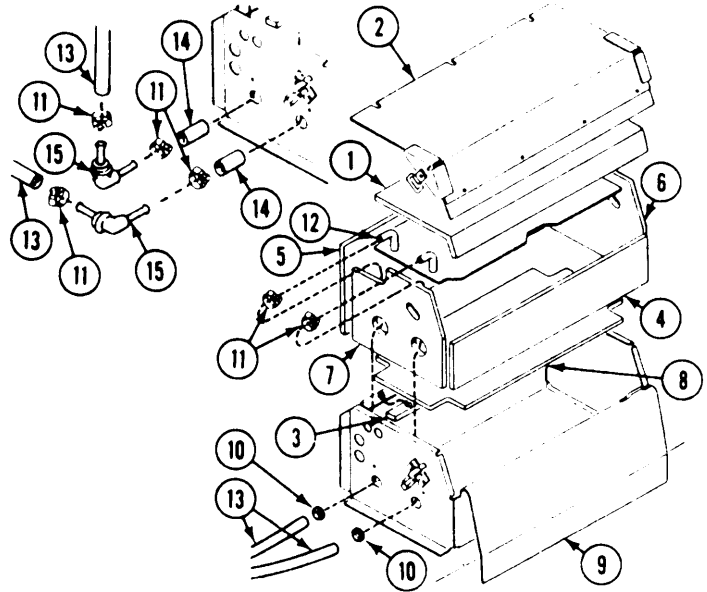

FOLLOW-THROUGH STEPS

1. Fill carrier cooling system (page 8–5).
2. Fill coolant heater system (page 32-10).
3. Start coolant heater (see your -10). Check heat exchanger for leaks. Turn heater off.
4. Raise and lock ramp (see your -10).
5. Stop/shutdown engine (see your -10).

END OF TASK

CHAPTER 14
**ELECTRICAL SYSTEM MAINTENANCE - WIRING HARNESS,
 RECEPTACLE, AND CABLE REPAIR**

TASK INDEX

<u>Task</u>	<u>Page</u>	<u>Task</u>	<u>Page</u>
Multiple Pin and Socket Identification	14-2	Repair Cable Assembly	14-9
Repair Wiring Harness	14-3	Repair Intervehicle Power Cable (M577A2 and M1068 Only)	14-11
Repair Receptacle	14-7		

MULTIPLE PIN AND SOCKET IDENTIFICATION

1. It is important to identify the correct pins and sockets for repair when troubleshooting electrical connectors and receptacles.
2. Letters or other markings are stamped next to each pin and corresponding socket to ensure proper identification.
3. Following are examples of typical connectors found in carriers.

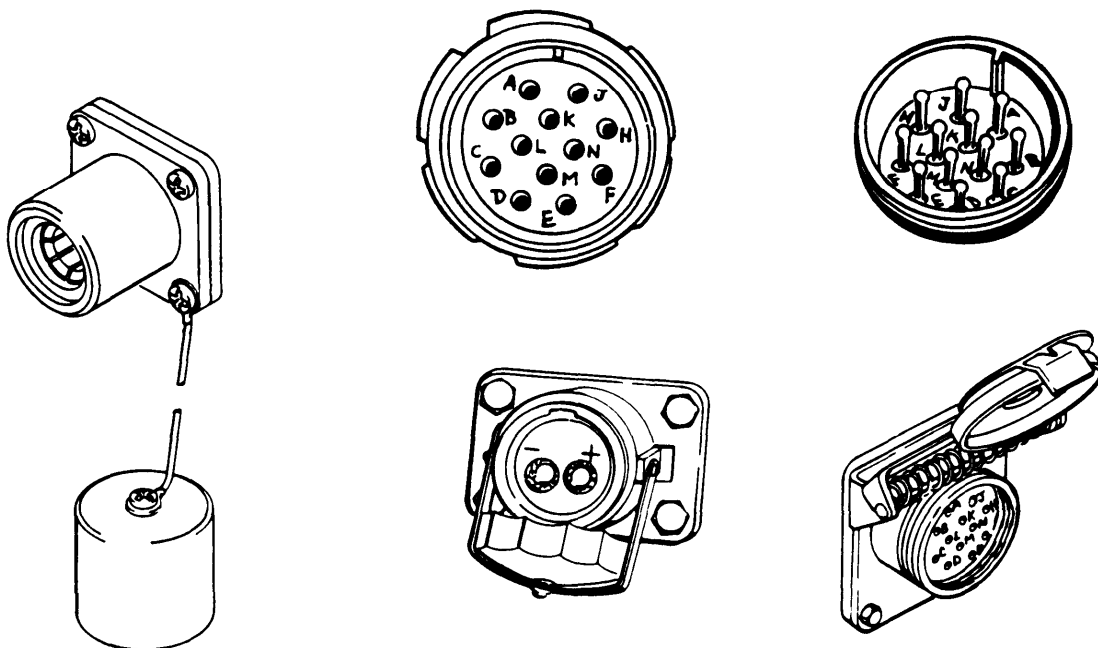

END OF TASK

REPAIR WIRING HARNESS

DESCRIPTION

This task covers: Remove (page 14-3). Install (page 14-5).

INITIAL SETUP

Tools:

General Mechanics Tool Kit (Item 30, App D)
 Hacksaw Blade (Item 14, App D)
 Hacksaw Frame (Item 27, App D)
 Soldering Gun (Item 34, App D)
 Heater Gun (Item 35, App D)
 Digital Multimeter (Item 43, App D)
 Electrical Tool Kit (Item 75, App D)

Materials/Parts:

Insulation sleeving (Item 21 thru 25, App C)
 Solder (Item 57, App C)

Personnel Required:

Unit Mechanic

References:

See your -10
 See your -24P

Equipment Conditions:

Engine stopped/shutdown (see your -10)
 Carrier blocked (see your -10)
 Battery ground lead disconnected (page 13-2)

REMOVE

1. Remove male connector from harness lead.

- a. Slide shell (1) back on lead (2).
- b. Clip contact pin (3) from lead (2). Discard pin.
- c. Remove washer (4) or slotted washer (5) and shell (1) from lead (2).

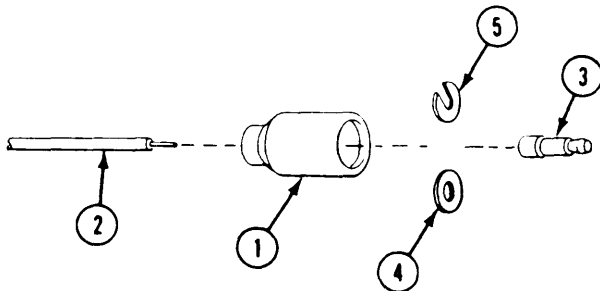

2. Remove female connector from harness lead,

- a. Slide shell (6) back on lead (7).
- b. Slide sleeve (8) back from contact socket (9).
- c. Clip socket (9) from lead (7). Discard socket.

d. Remove sleeve (8) and shell (6) from lead (7).

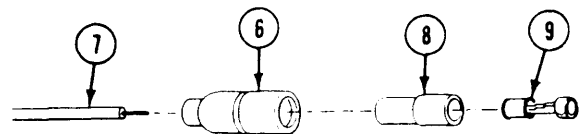

3. Remove terminal connector from harness lead.

- a. If lead (10) has nipple (11), slide nipple back on lead.

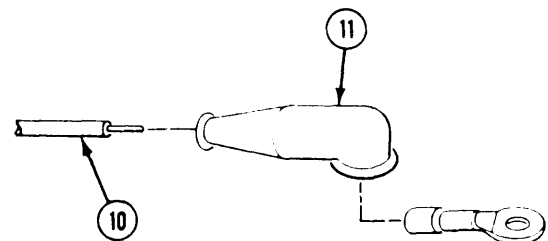

GO TO NEXT PAGE

- b. If lead (1) has insulated sleeving (2), cut and discard sleeving from lead.

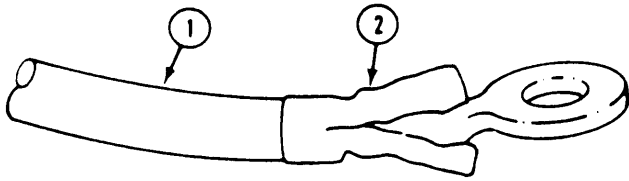

- c. If lead (3) is of large diameter, place in vise (4). Cut lead as close as possible to terminal (5). Use hacksaw frame and blade. Discard terminal.

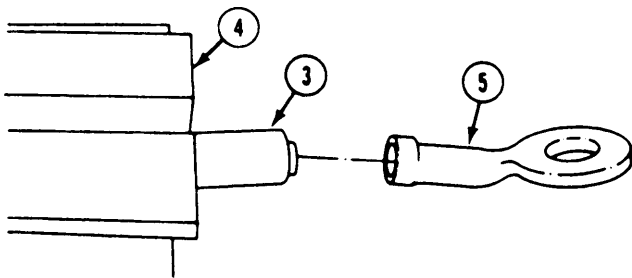

- d. If lead (6) is of small diameter, cut lead as close as possible to terminal (7). Discard terminal.

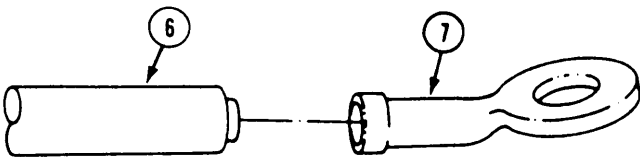

NOTE

Unit Maintenance can only repair multi-pin plugs with up to three sockets. For plugs with more than three sockets, notify your supervisor.

5. Remove multiple connectors the same way as single connectors. Be sure to tag leads to ensure correct installation. See steps 1 and 2 above.

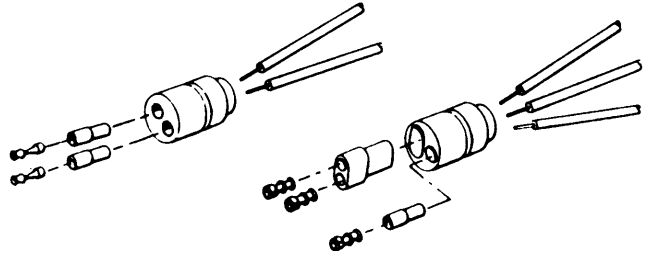

NOTE

For wiring harness repair, it may be necessary to remove Y-type adapters and dummy plugs.

6. Remove Y-type adapter or dummy plug from harness lead,

- a. Pull harness leads (8) from Y-type adapter (9). Remove adapter.

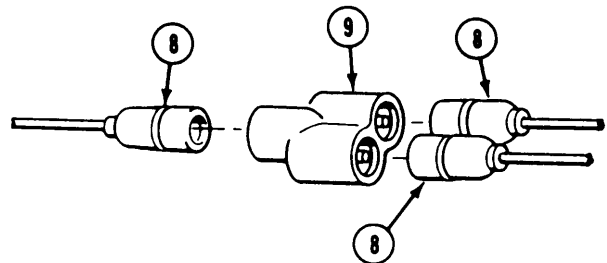

- b. Pull dummy plug (10) from male or female connector (11).

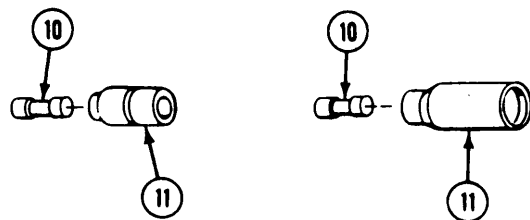

INSTALL

NOTE

If replacing lead, cut new wire from bulk supply. Measure original length, gage, and type of wire.

7. Install male connector on harness lead.

- Strip insulation from lead (1) to uncover just enough wire to fill contact pin well.
- Slide shell (2) and washer (3), if removed, over lead (1).

CAUTION

Crimping lower part of pin may damage pin and it will not hold lead. Crimp only middle part of contact pin with correct size die.

- Insert lead (1) into new pin (4) and crimp.
- If removed, place slotted washer (5) on lead (1) under pin (4) and pull shell (2) over washer (3 or 5) and pin.

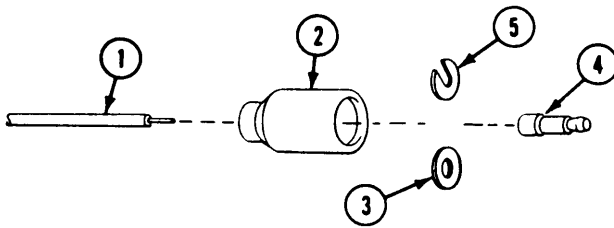

8. Install female connector on harness lead.

- Strip insulation from lead (6) to uncover just enough wire to fill contact socket well.

- Slide shell (7) and sleeve (8) over lead (6).
- Insert lead (6) in new socket (9) and crimp or solder.
- Slide sleeve (8) and shell (7) over socket (9).

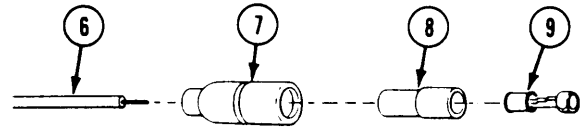

9. Install terminal connector on harness lead,

- If nipple (10) was removed from lead (11), strip insulation from lead to uncover just enough wire to fill terminal well. Slide nipple over lead.

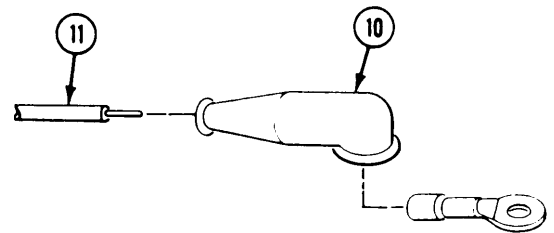

- If insulated sleeving (12) was removed from lead (13), slide new insulated sleeving on lead. Strip insulation from lead to same length as crimp (14) on terminal (15).

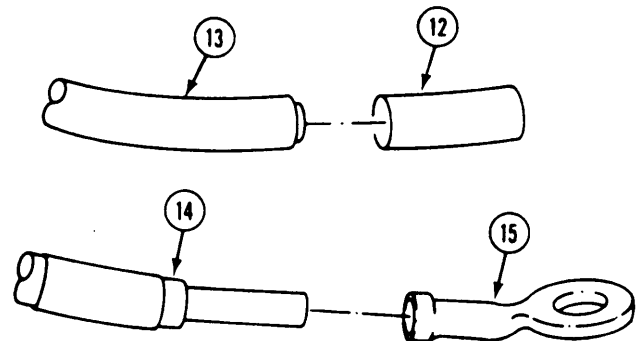

GO TO NEXT PAGE

- c. If large diameter lead (1), fill crimp (2) on terminal (3) with solder. Use soldering gun. Insert lead into melted solder in crimp. Allow to cool.

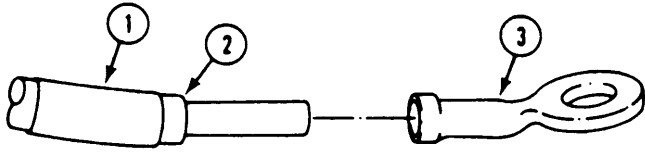

- d. If small diameter lead (4), position terminal (5) on lead. Crimp terminal on lead. Use crimping tool from electrical tool kit.

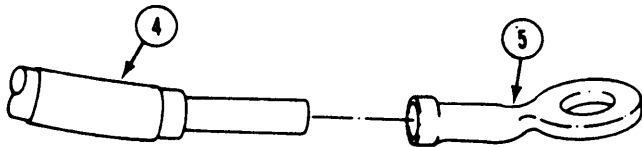

- e. Heat shrink those leads with insulated sleeving (6) on terminal (7). Use heat gun.

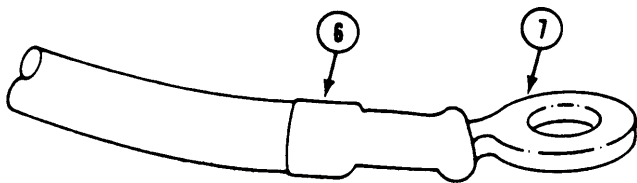

10. Install multiple connectors the same way as single connectors. See steps 7 and 8 above.

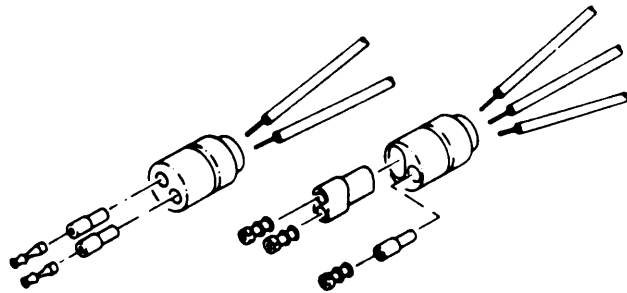

11. If removed, install Y-type adapters and dummy plugs.

- a. Install Y-type adapter (8) on harness leads (9).

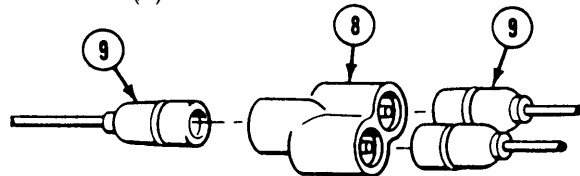

- b. Install dummy plugs (10) in male or female connector (11).

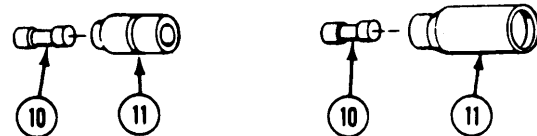

FOLLOW-THROUGH STEPS

1. Use multimeter to perform continuity check before connecting batteries.
2. Connect battery ground lead (page 13-2).
3. Turn MASTER SWITCH ON (see your -10).
4. Turn MASTER SWITCH OFF (see your -10).

END OF TASK

REPAIR RECEPTACLE

DESCRIPTION

This task covers: Remove (page 14-7). Install (page 14-8).

INITIAL SETUP

Tools:

General Mechanics Tool Kit (Item 30, App D)
Soldering Gun (Item 34, App D)
Digital Multimeter (Item 43, App D)
Electrical Tool Kit (Item 75, App D)

Materials/Parts:

Insulation sleeving (Item 21 thru 25, App C)
Solder (Item 57, App C)

Personnel Required:

Unit Mechanic

References:

See your -10
See your -24P

Equipment Conditions:

Engine stopped/shutdown (see your -10)
Battery ground lead disconnected (page 13-2)
Carrier blocked (see your -10)

REMOVE

NOTE

Use same procedure for repairing single or multiple lead, and male or female receptacle.

- Loosen nut (1) from receptacle (2). Slide nut back on leads (3).
- Remove grommet (4) with contacts (5) from rear of receptacle (2).
- Push leads (3) into grommet (4) until contacts (5) are fully exposed on other side of grommet. Remove grommet (4) and nut (1) from leads (3).
- Clip or desolder leads from contacts. Use soldering gun. Discard contacts.

CLEAN, INSPECT, AND REPAIR

- Check wire leads. Look for damaged insulation or broken wires. If wire leads have been taped together, remove tape. Scrape wire lead covering with your thumbnail to see if covering peels off. Replace bad leads.
- Check contact pins, contact sockets, and terminals. Replace burned, bent, or broken parts.
- Check shells, sleeves, and nipples. Replace cut, torn, or damaged parts.

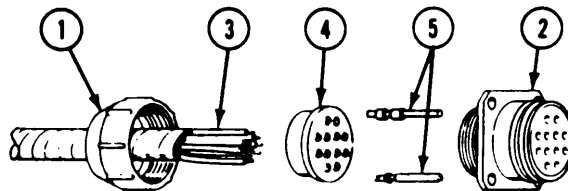

GO TO NEXT PAGE

INSTALL

NOTE

If replacing lead, cut new wire from bulk supply. Measure original length, gage, and type of wire.

8. Slide nut (1) over leads (2).
9. Strip insulation from leads (2) to expose just enough wire to fill holes in contacts (3).
10. Push leads (2) through grommet (4) and insert in new contacts (3). Solder leads (2) in contacts (3). Use soldering gun.

NOTE

Make sure leads pass through proper lettered holes in grommet.

11. Align and install grommet (4) in receptacle (5). Secure with nut (1).

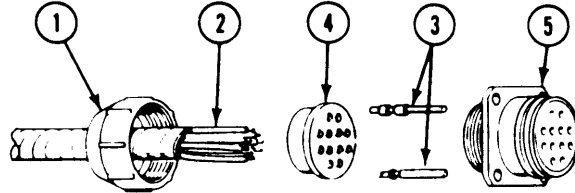

FOLLOW-THROUGH STEPS

- | | |
|--|---|
| 1. Use multimeter to perform continuity check before connecting batteries. | 3. Turn MASTER SWITCH ON to check for proper receptacle repair. |
| 2. Connect battery ground lead (page 13-2). | 4. Turn MASTER SWITCH OFF (see your -10). |

END OF TASK

REPAIR CABLE ASSEMBLY

DESCRIPTION

This task covers: Remove (page 14-9). Install (page 14-10).

INITIAL SETUP

Tools:

General Mechanics Tool Kit (Item 30, App D)
Soldering Gun (Item 34, App D)
Digital Multimeter (Item 43, App D)
Electrical Tool Kit (Item 75, App D)

Materials/Parts:

Insulation sleeving (Item 21 thru 25, App C)
Solder (Item 57, App C)

Personnel Required:

Unit Mechanic

References:

see your -10
see your -24P

Equipment Conditions:

Engine stopped/shutdown (see your -10)
Battery ground lead disconnected (page 13-2)
Carrier blocked (see your -10)

REMOVE

NOTE

Use same procedure for repairing single or multiple lead, and male or female receptacle.

1. Loosen retaining nut (1) from plug (2). Slide nut back on cable (3).
2. Remove grommet (4) with contacts (5) from rear of plug (2).
3. Remove plug (2) and coupling nut (6) from cable (3).
4. Push leads of cable (3) into grommet (4) until contacts (5) are fully exposed on other side of grommet. Clip or desolder leads from contacts. Use soldering gun. Discard contacts.
5. Remove grommet (4) and retaining nut (1) from cable (3).

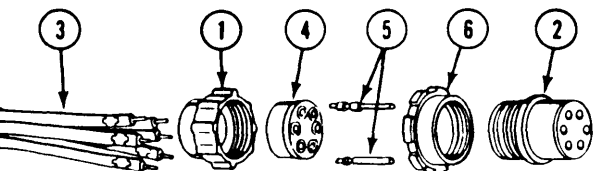

CLEAN, INSPECT, AND REPAIR

6. Check wire leads. Look for damaged insulation or broken wires. If wire leads have been taped together, remove tape. Scrape wire lead covering with your thumbnail to see if covering peels off. Replace bad leads.
7. Check contact pins, contact sockets, and terminals. Replace burned, bent, or broken parts.
8. Check shells, sleeves, and nipples. Replace cut, torn, or damaged parts.

GO TO NEXT PAGE

INSTALL

NOTE

If replacing lead, cut new wire from bulk supply. Measure original length, gage, and type of wire.

9. Strip insulation from leads of cable (1) to expose just enough wire to fill holes in contacts (2).
10. Slide retaining nut (3) and coupling nut (4) on cable (1).
11. Push leads of cable (1) through grommet (5) and insert in new contacts (2).

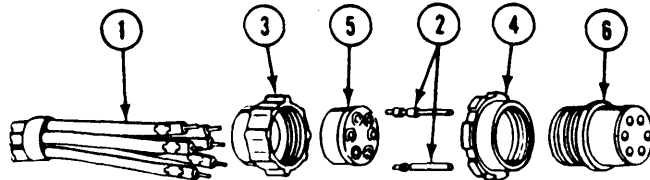

NOTE

Make sure leads pass through proper lettered holes in grommet.

12. Solder leads of cable (1) in contacts (2) and press contacts into grommet (5). Use soldering gun.
13. Align and install grommet (5) in plug (6). Secure with retaining nut (3).

FOLLOW-THROUGH STEPS

1. Use multimeter to perform continuity check before connecting batteries.
2. Connect battery ground lead (page 13-2).
3. Turn MASTER SWITCH ON to check for proper cable repair.
4. Turn MASTER SWITCH OFF (see your -10).

END OF TASK

REPAIR INTERVEHICLE POWER CABLE (M577A2 AND M1068 ONLY)

INITIAL SETUP

Tools:

General Mechanics Tool Kit (Item 30, App D)
Soldering Torch Kit (Item 68, App D)

References:

See your -10
See your -24P

Personnel Required:

Unit Mechanic

Equipment Conditions:

Power cable removed from earner
(see your -10)

REMOVE

1. Remove twelve screws (1), washers (2), and cover (3) from connector (4).

NOTE

Note cable polarity position before removing from connector.

2. Remove four screws (5), washers (6), and two cables (7) from two connectors (4).
3. Remove four terminals two (-), and two (+), from cables (7). Use soldering torch (page 14-3).

INSTALL

4. Install four terminals two (-), and two (+), on cables (7). Use soldering torch (page 14-3).

CAUTION

Do not switch cable polarity when securing cables to connectors.

5. Secure two cables (7) to two connectors (4) with four screws (5) and washers (6).
6. Secure two covers (3) to two connectors (4) with twelve screws (1) and washers (2).

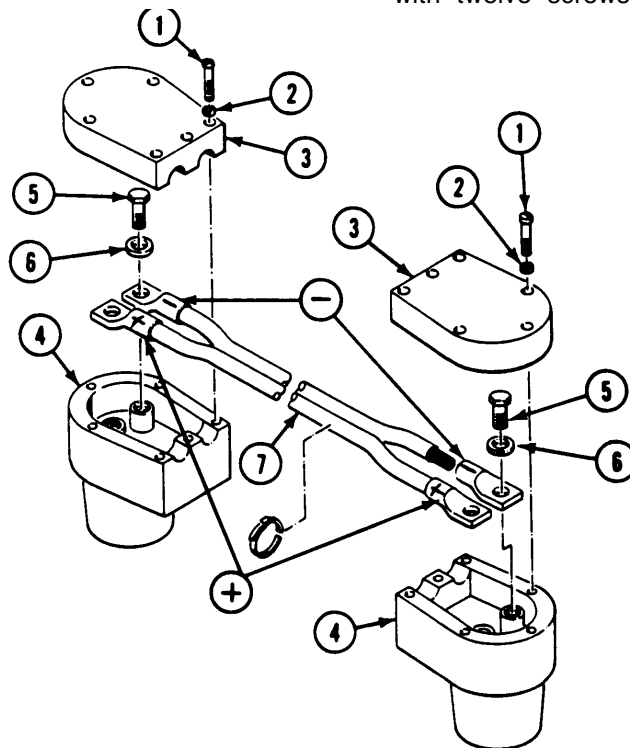

END OF TASK

CHAPTER 15
ELECTRICAL SYSTEM MAINTENANCE-POWER PLANT WIRING
HARNES AND RELATED COMPONENTS

TASK INDEX

<u>Task</u>	<u>Page</u>	<u>Task</u>	<u>Page</u>
Replace Engine Low Oil Pressure Switch	15-2	Replace Differential Switch Lead	15-5
Replace Engine Coolant Temperature Switch	15-3	Replace Transmission High Oil Temperature Switch	15-6
Replace Differential High Oil Temperature Switch	15-4	Replace Power Plant Wiring Harness . .	15-7 ■

REPLACE ENGINE LOW OIL PRESSURE SWITCH

INITIAL SETUP

Tools:

General Mechanics Tool Kit (Item 30, App D)

Materials/Parts:

Sealing compound (Item 46, App C)

Personnel Required:

Unit Mechanic

References:

See your -10

Equipment Conditions:

Engine stopped/shutdown (see your -10)
Carrier blocked (see your -10)
Battery ground lead disconnected (13-2)
Trim vane lowered and power plant front access door open (see your -10)

REMOVE

1. Disconnect circuit 34 lead (1) from oil pressure switch (2).
2. Remove switch (2) from bushing (3).
3. If needed, remove bushing (3) from engine block (4).

INSTALL

4. If removed, coat threads of bushing (3) with sealing compound.
5. Install bushing (3) in engine block (4).
6. Install switch (2) in bushing (3).
7. Connect circuit 34 lead (1) to switch (2).

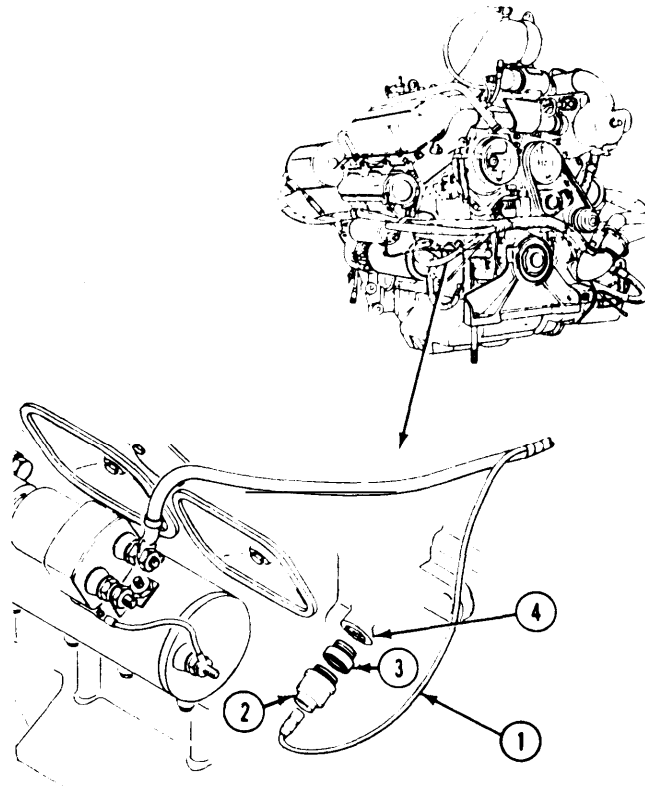

FOLLOW-THROUGH STEPS

1. Connect battery ground lead (page 13-2).
2. Turn MASTER SWITCH ON and observe low oil pressure warning light. Light should go ON (see your -10).
3. Start engine and check for oil leaks at engine low oil pressure switch. Low oil pressure warning light should go out after engine is started. Stop engine (see your -10).
4. Turn MASTER SWITCH OFF (see your -10).
5. Close power plant front access door, and raise trim vane (see your -10).

END OF TASK

REPLACE ENGINE COOLANT TEMPERATURE SWITCH

INITIAL SETUP

Tools:

General Mechanics Tool Kit (Item 28, App D)

Materials/Parts:

Sealing compound (Item 54, App C)

Personnel Require:

Unit Mechanic

References:

See your -10

Equipment Conditions:

Engine stopped/shutdown (see your -10)
 Carrier blocked (see your -10)
 Trim vane lowered and power plant front access door open (see your -10)
 Coolant level drained to below thermostat housing (page 8-3)

REMOVE

1. Disconnect circuit 33 lead (1) from engine coolant temperature switch (2).
2. Remove switch (2) from thermostat housing (3).

INSTALL

3. Coat threads of switch (2) with sealing compound.
4. Install switch (2) in thermostat housing (3).
5. Connect circuit 33 lead (1) to switch (2).

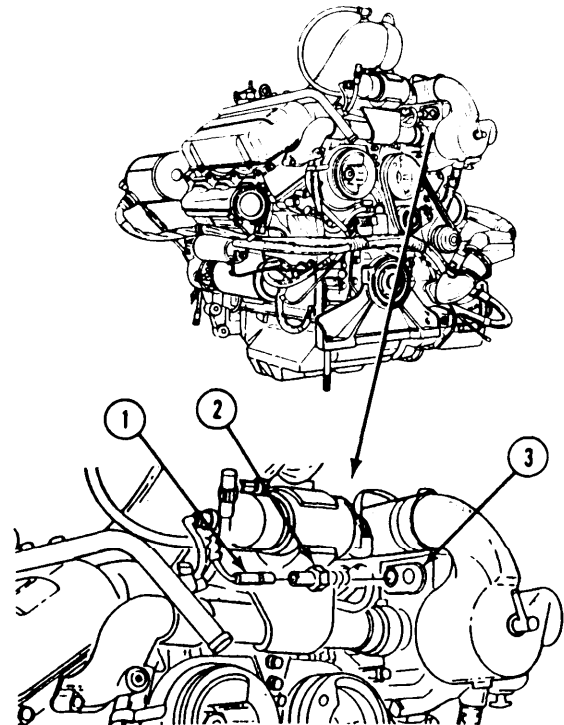

FOLLOW-THROUGH STEPS

1. Refill cooling system (page 8-5).
 2. Start engine (see your -10). Check for coolant leaks at engine coolant temperature switch (page 3-144).
 3. Stop/shutdown engine (see your -10).
 4. Close power plant front access door, and raise trim vane (see your -10).
-

END OF TASK

REPLACE DIFFERENTIAL HIGH OIL TEMPERATURE SWITCH

INITIAL SETUP

Tools:

General Mechanics Tool Kit (Item 30, App D)

References:

See your -10

Materials/Parts:

Sealing compound (Item 46, App C)

Personnel Required:

Unit Mechanic

Equipment Conditions:

Engine stopped/shutdown (see your -10)
Carrier blocked (see your -10)
Differential drained (see your -LO)
Trim vane lowered and power plant front access door open (see your -10)

REMOVE

1. Disconnect circuit 328 lead (1) from differential high oil temperature switch (2).
2. Remove switch (2) from tee (3).

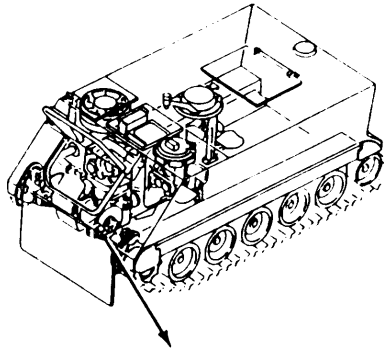

INSTALL

3. Coat threads of switch (2) with sealing compound.
4. Install switch (2) in tee (3). Tighten switch.
5. Connect circuit 328 lead (1) to switch (2).

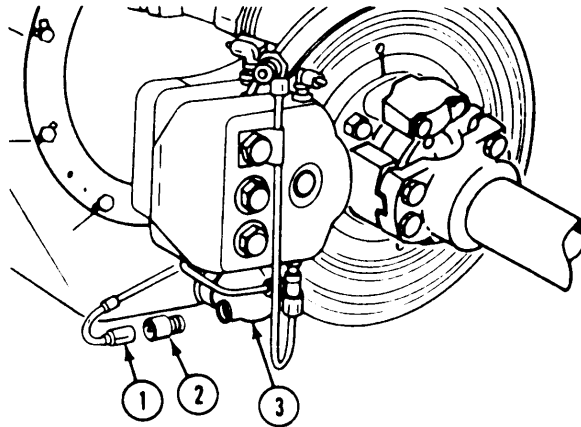

FOLLOW-THROUGH STEPS

1. Refill differential (see your -LO).
 2. Start engine (see your -10). Check for oil leaks at differential high oil temperature switch.
 3. Stop/shutdown engine (see your -10).
 4. Close power plant front access door, and raise trim vane (see your -10).
-

END OF TASK

REPLACE DIFFERENTIAL SWITCH LEAD

INITIAL SETUP

Tools:

General Mechanics Tool Kit (Item 30, App D)

Materials/Parts:

Self-locking nut

Personnel Required:

Unit Mechanic

References:

See your -10

Equipment Conditions:

Engine stopped/shutdown (see your -10)
Trim vane lowered and power plant front access door open (see your -10)

REMOVE

1. Remove locknut (1), clamp (2), and screw (3) from clamp (4). Discard locknut.
2. Disconnect circuit 328 lead (5) from differential high oil temperature switch (6) and power plant wiring harness (7). Remove lead.
3. If replacing lead (5), remove clamp (2) from lead.

INSTALL

4. If removed, install clamp (2) on lead (5).
5. Route lead (5) along differential and connect lead to power plant wiring harness (7) and switch (6).
6. Place clamp (2) on clamp (4). Secure with screw (3) and new locknut (1).

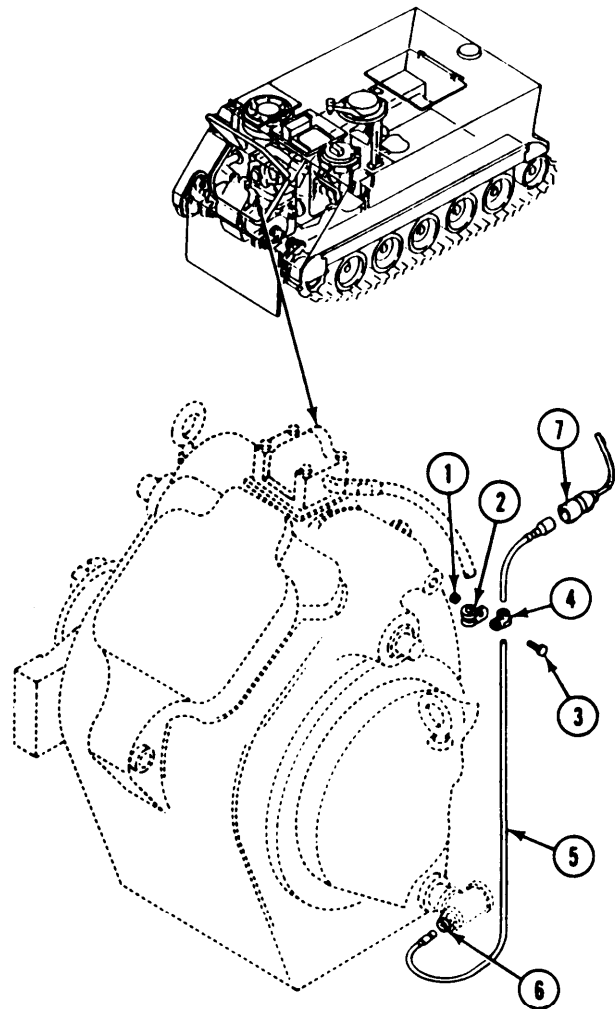

FOLLOW-THROUGH STEPS

1. Close power plant front access door and raise trim vane (see your -10).
-

END OF TASK

REPLACE TRANSMISSION HIGH OIL TEMPERATURE SWITCH

INITIAL SETUP

Tools:

- General Mechanics Tool Kit (Item 30, App D)
- Socket Wrench Set (Item 89, App D)
- Torque Wrench (Item 95, App D)

Materials/Parts:

- Sealing compound (Item 50, App C)

Personnel Required:

- Unit Mechanic

References:

- see your -10

Equipment Conditions:

- Engine stopped/shutdown (see your -10)
-

REMOVE

1. Disconnect circuit 327 lead (1) from transmission high oil temperature switch (2).
2. Remove switch (2) from tee (3).

CLEAN, INSPECT, AND REPAIR

3. Check threads on switch. Remove burrs. Replace switch that has stripped threads.

INSTALL

4. Coat threads of switch (2) with sealing compound.
5. Install switch (2) in tee (3). Tighten switch to 240-264 lb-in (27-34 N•m) torque. Use torque wrench.
6. Connect circuit 327 lead (1) to switch (2).

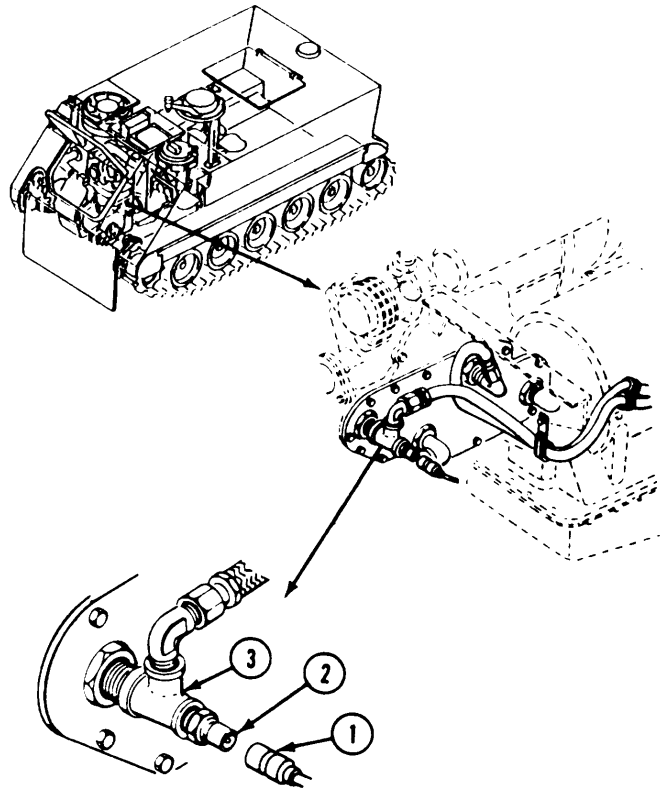

FOLLOW-THROUGH STEPS

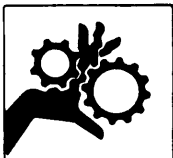

WARNING
Loose clothing is dangerous around moving belts and pulleys. You could get badly hurt if your clothes get caught in moving parts.

1. Start engine to check for oil leaks at transmission high oil temperature switch. Stop/shutdown engine (see your -10).
2. Close power plant front access door and raise trim vane (see your -10).

END OF TASK

REPLACE POWER PLANT WIRING HARNESS

DESCRIPTION

This task covers: Remove (page 15-7). Install (page 15-10).

INITIAL SETUP**Tools:**

General Mechanics Tool Kit (Item 30, App D)

Materials/Parts:

Lockwasher (4)

Personnel Required:

Unit Mechanic

References:

see your -10
see your -20

Equipment Conditions:

Ramp lowered (see your -10)
Engine stopped/shutdown (see your -10)
Carrier blocked (see your -10)
Battery ground rear lead disconnected (page 13-2)
Power plant rear access panel removed
(page 24-27, 24-29)
Power plant bottom access cover removed
(page 24-32)
Trim vane lowered and power plant front
access door open (see your -10)

REMOVE

1. Disconnect circuit 1B lead (1) from generator field switch (2) on secondary fuel filter.

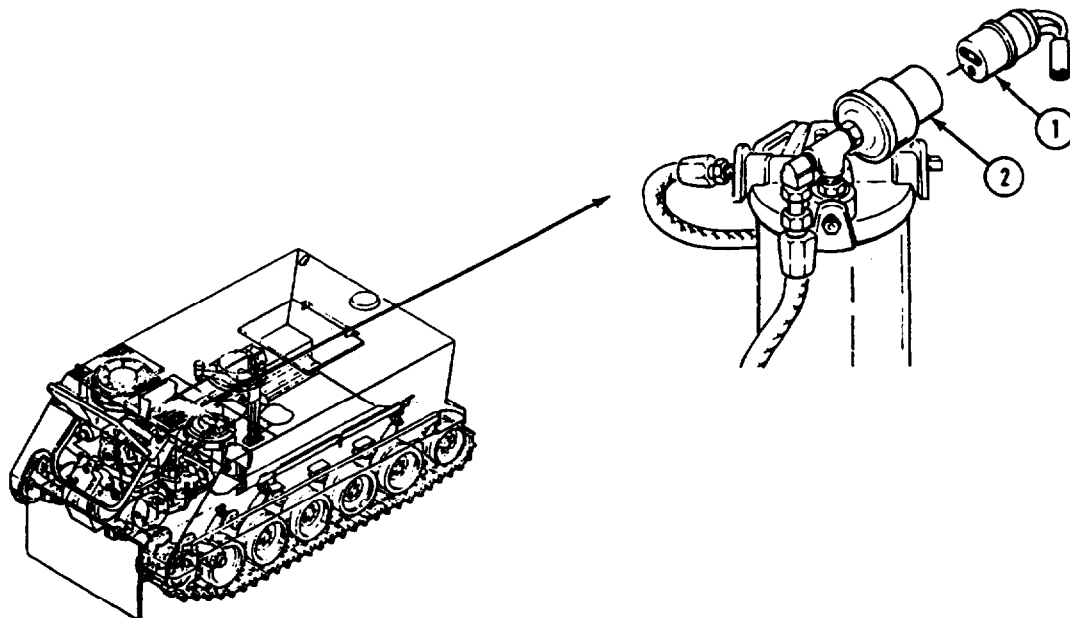

GO TO NEXT PAGE

2. Disconnect circuit 34 lead (1) from engine low oil pressure switch (2).
3. Removal nut (3), two lockwashers (4), and circuit 6 lead (5) from starter solenoid (6). Discard lockwashers.
4. Remove nut (7), two lockwasher (8), and circuit 74A lead (9) from solenoid (6). Discard lockwasher.
5. Disconnect circuit 327 lead (10) from transmission high oil temperature switch (11).
6. Disconnect circuit 33 lead (12) from engine coolant temperature switch (13).
7. Disconnect three power plant wiring harness connectors (14) from main wiring harness at driver's compartment bulkhead.

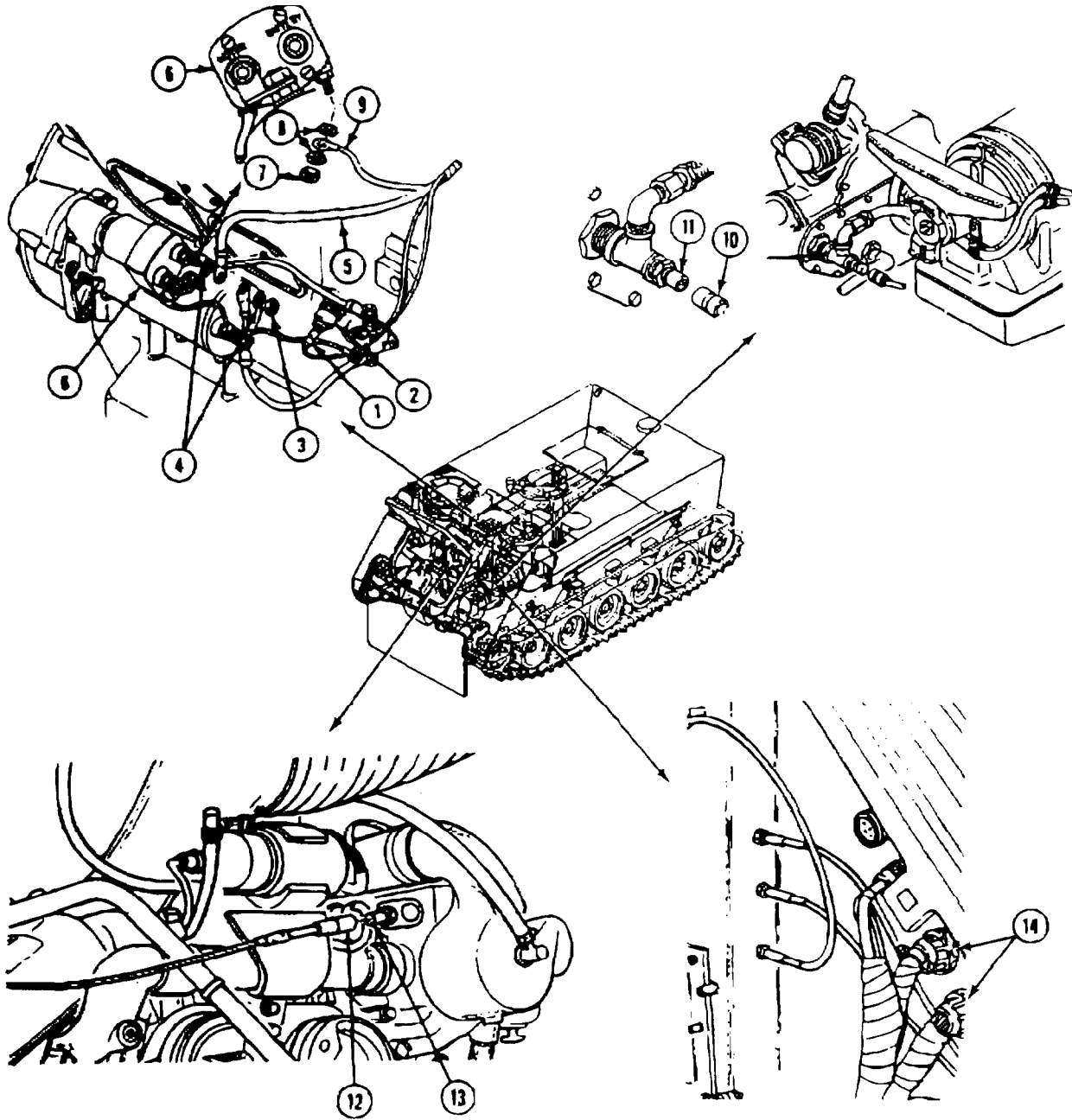

8. Disconnect circuit 328 lead (1) from differential high oil temperature switch (2).
9. Disconnect circuit 406-406A lead (3) from air box heater wiring harness.
10. Disconnect connector (4) from generator (5).

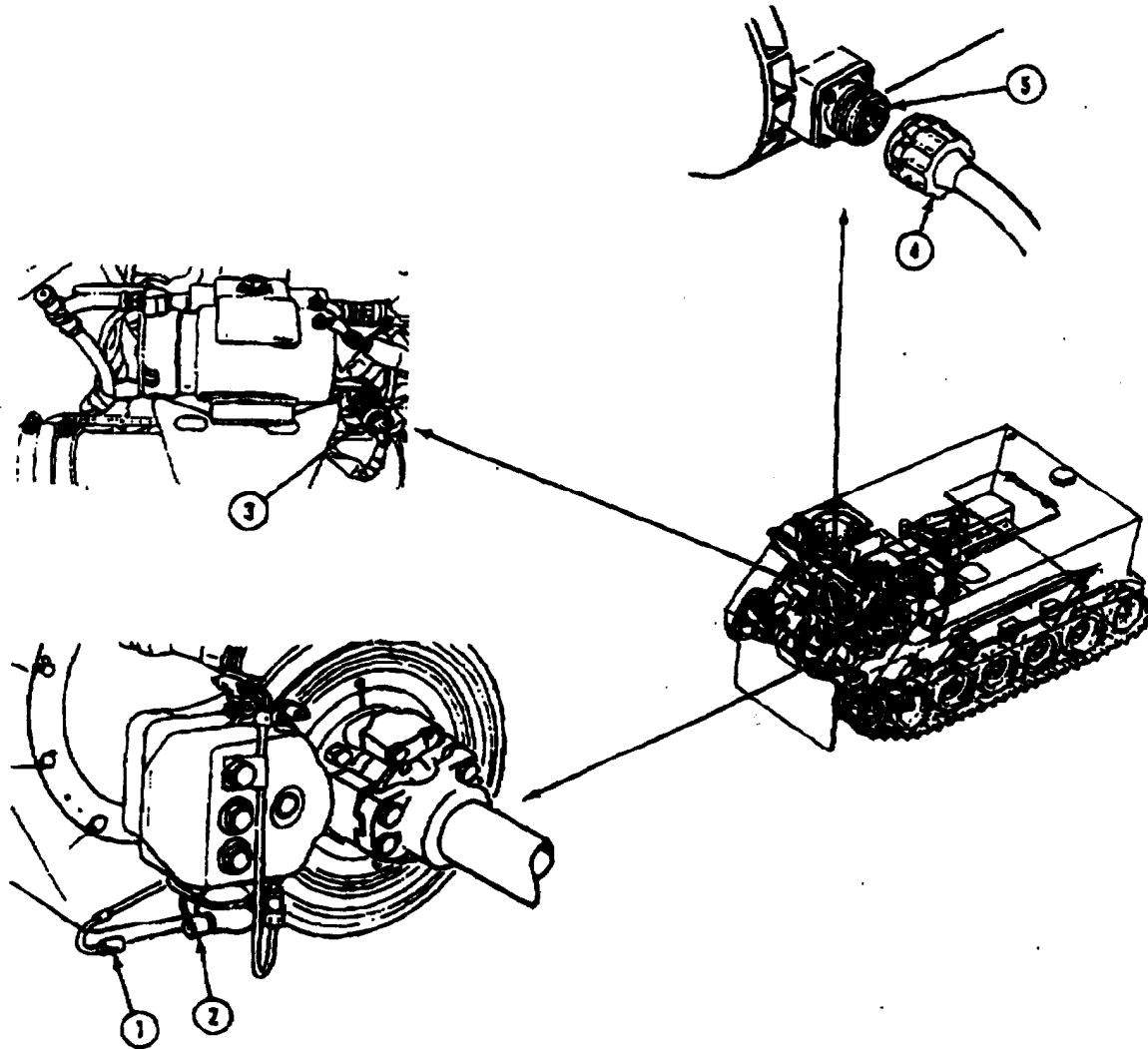

GO TO NEXT PAGE

- 1 1. Disconnect circuit 641E and 641F leads (1 and 2) from suspension lockout solenoid (3) (M741A1 only).
- 1 2. Remove 11 screws (4), 8 clamps (5), 8 nuts (6), 3 straps (7), and power plant wiring harness (8) from power plant.

INSTALL

13. Install power plant wiring harness (8) on power plant. Secure with 3 straps (7), 8 nuts (6), 8 clamps (5), and 11 screws (4).
14. Connect circuits 641F and 641E leads (1 and 2) to suspension lockout solenoid (3).

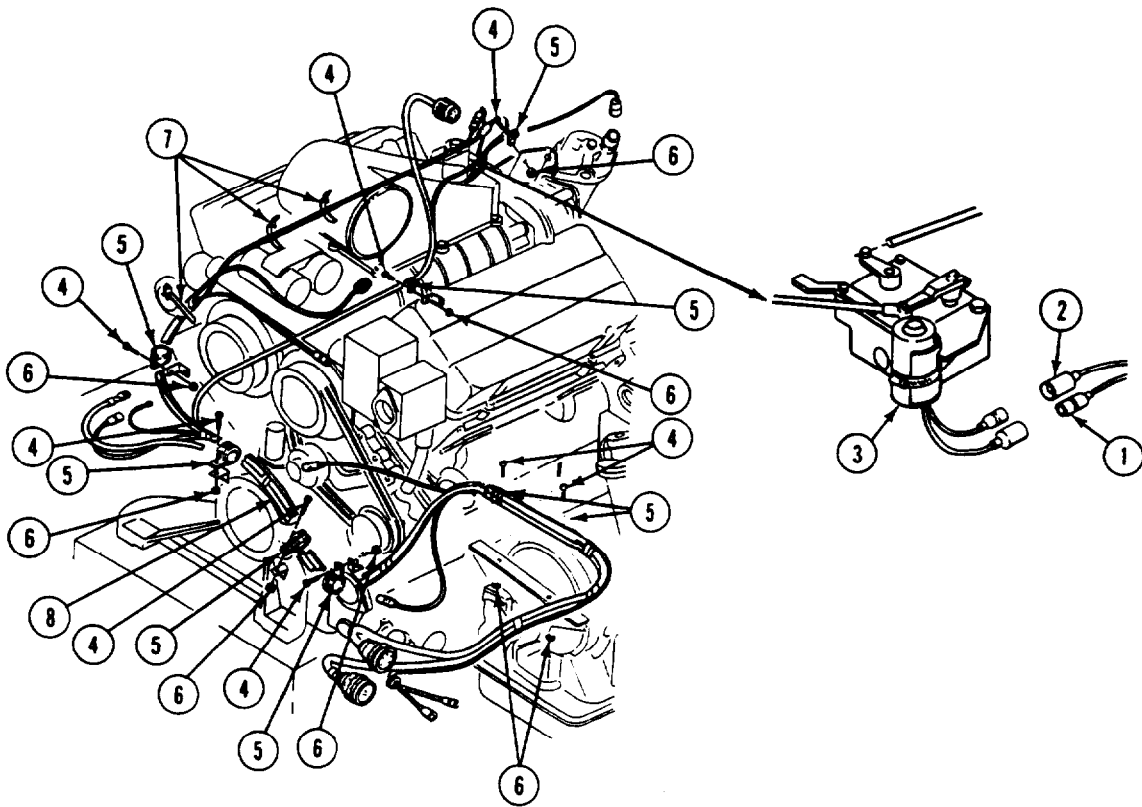

15. Connect circuit 1, 2, 3, and 3A lead (1) to generator (2).
16. Connect circuit 406-406A lead (3) to air box beater wiring harness.
17. Connect circuit 328 lead (4) to differential high oil temperature switch (5).

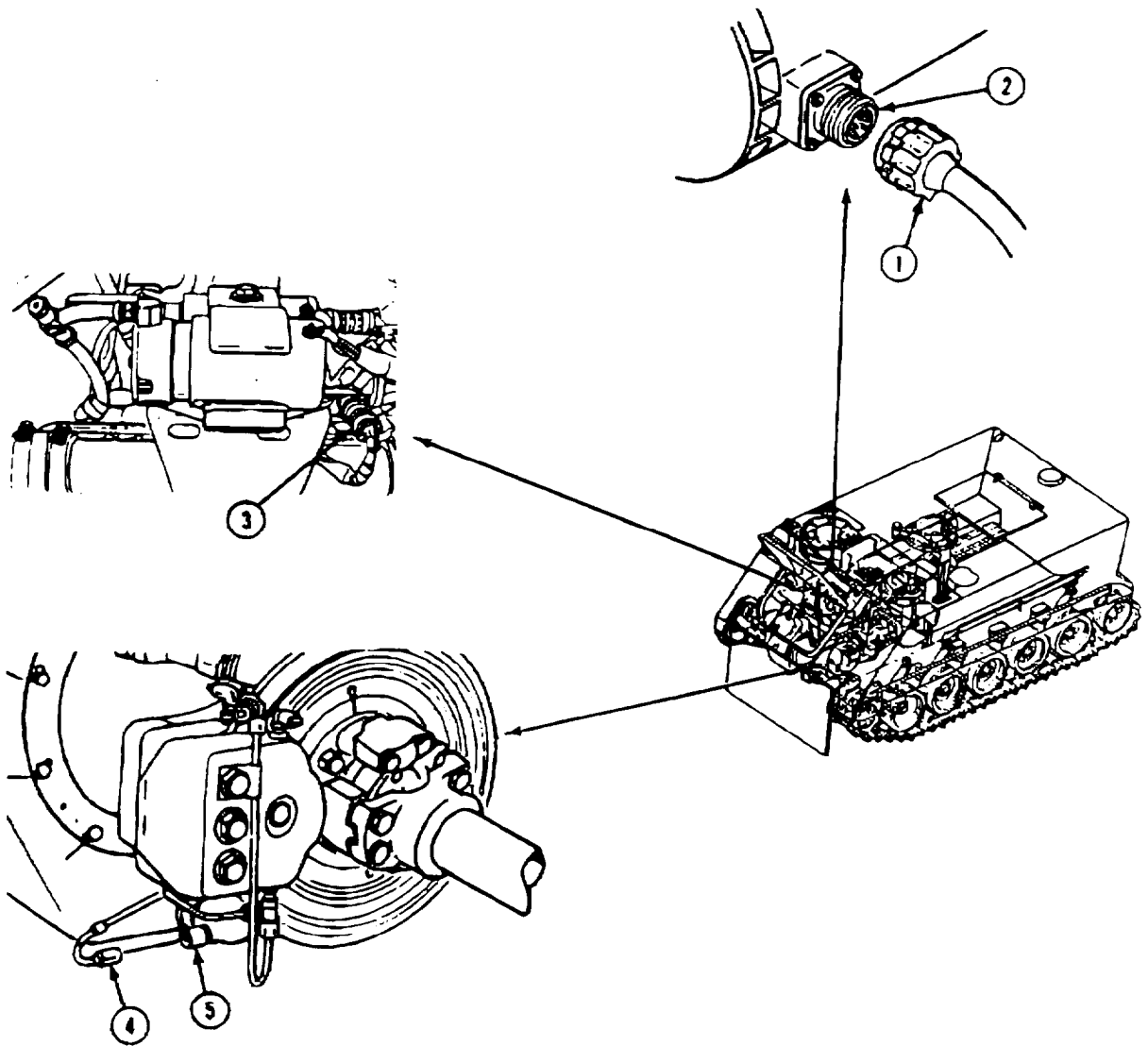

GO TO NEXT PAGE

18. Connect three power plant wiring harness connectors (1) to main wiring harness at driver's compartment bulkhead.

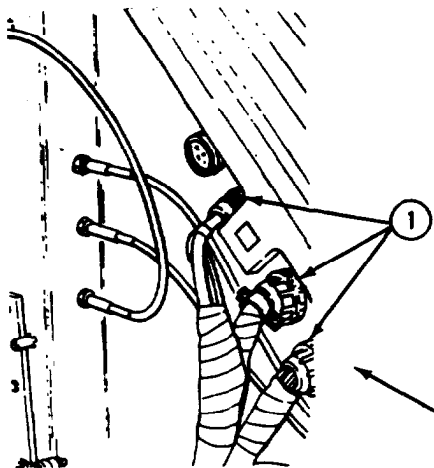

20. Connect circuit 327 lead (4) to transmission high oil temperature switch (5).

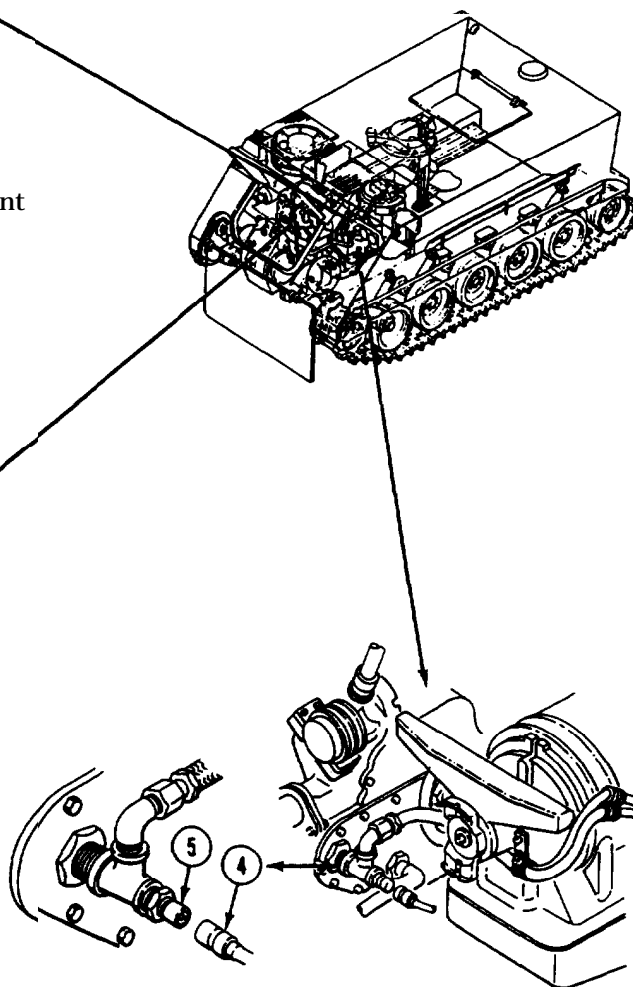

19. Connect circuit 33 lead (2) to engine coolant temperature switch (3).

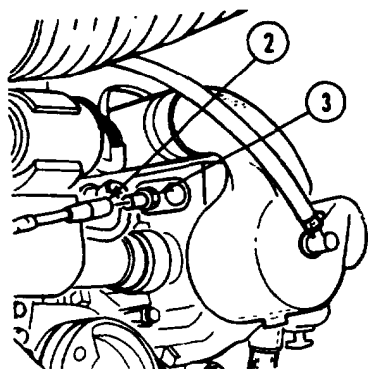

21. Install circuit 74A lead (1) and two new lockwashers (2) on starter solenoid (3). Secure with nut (4).

22. Install circuit 6 lead (5) and two new lockwashers (6) on solenoid (3). Secure with nut (7).

23. Connect circuit 34 lead (8) to engine low oil pressure switch (9).

24. Connect circuit 1B lead (10) to generator field switch (11) on secondary fuel filter.

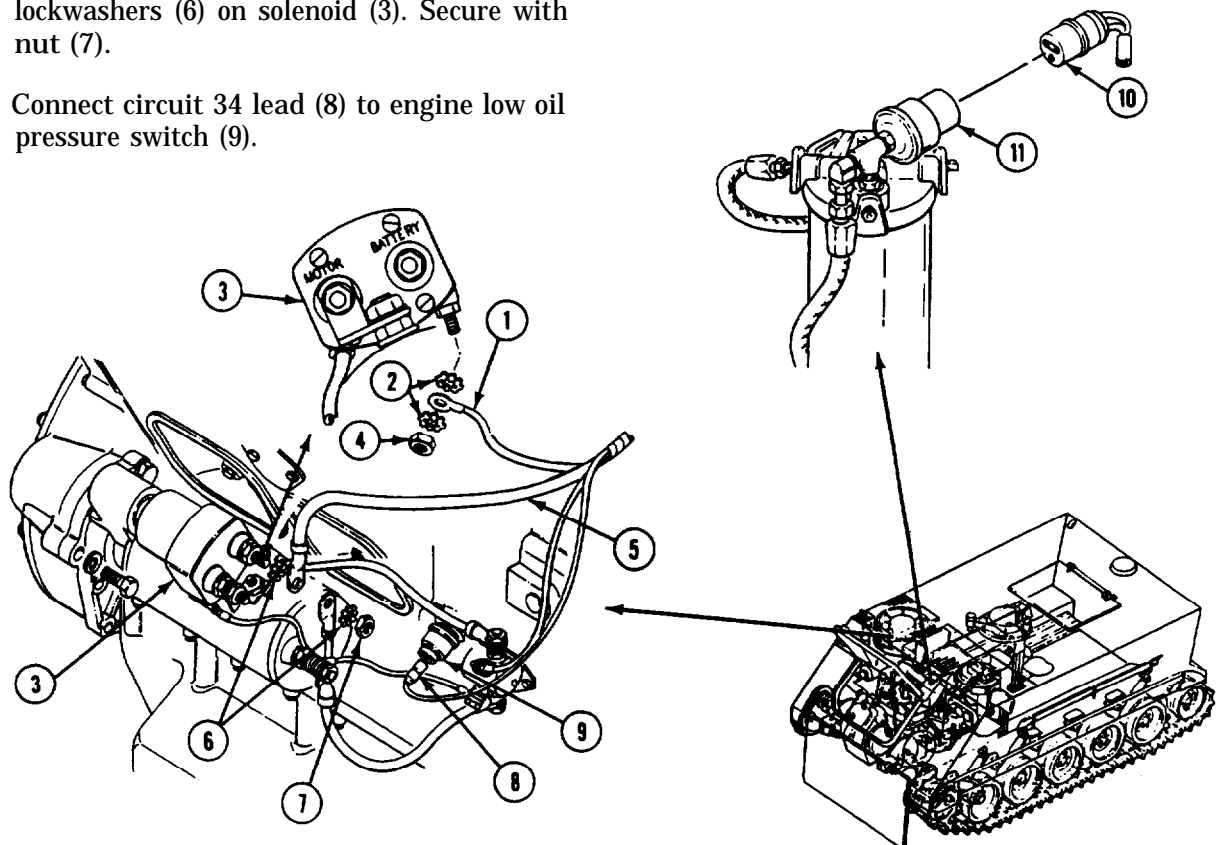

FOLLOW-THROUGH STEPS

- | | |
|---|--|
| <p>1. Connect battery ground lead (page 13-2).</p> <p>2. Install power plant rear access panel (page 24-27, 24-29).</p> <p>3. Start engine (see your -10). Check that power plant wiring harness operates properly.</p> <p>4. Raise and lock ramp (see your -10).</p> | <p>5. Stop/shutdown engine (see your -10).</p> <p>6. Close power plant front access door and raise trim vane (see your -10).</p> <p>7. Install power plant bottom access cover (page 24-32).</p> |
|---|--|

END OF TASK

CHAPTER 16
ELECTRICAL SYSTEM MAINTENANCE-BILGE PUMP, WIRING
AND RELATED COMPONENTS

TASK INDEX

<u>Task</u>	<u>Page</u>	<u>Task</u>	<u>Page</u>
Replace Front Bilge Pump and Strainer	16-2	Replace Rear Bilge Pump and Strainer	16-8
Replace Front Bilge Pump Pipes	16-5	Replace Rear Bilge Pump Pipes	16-11
Replace Front Bilge Valve	16-7	Replace Bilge Pump Circuit Breakers	16-12

REPLACE FRONT BILGE PUMP AND STRAINER

DESCRIPTION

This task covers: Remove (page 16-2). Install (page 16-3).

INITIAL SETUP

Tools:

General Mechanics Tool Kit (Item 30, App D)
Adjustable Wrench (Item 80, App D)
Pipe Wrench (Item 86, App D)

Materials/Parts:

Sealing compound (Item 46, App C)
Adhesive (Item 52, App C)
Cushion (3)
Key washer (3)
Lockwasher (5)
Lockwasher (2)

Personnel Required:

Unit Mechanic

References:

See your -10

Equipment Conditions:

Engine stopped/shutdown (see your -10)
Carrier blocked (see your -10)
Trim vane lowered (see your -10)
Hull front access cover removed (page 24-24)
Battery ground lead disconnected (page 13-2)

REMOVE

NOTE

If only strainer is to be replaced, see steps 1, 2, 15, and 16.

1. Disconnect lead (1) from bilge pump (2).
2. Remove two screws (3), lockwashers (4), and strainer (5) from hull weldnuts. Discard lockwashers.

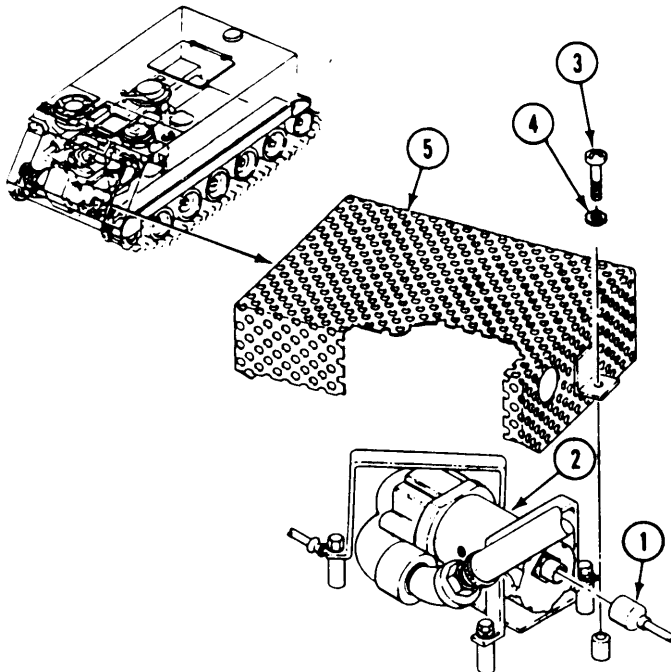

3. Remove screw (6), three lockwashers (7), and ground lead (8) from strap (9). Discard lockwashers.
4. Remove three screws (10), key washers (11), and two straps (9 and 12). Discard key washers.
5. Loosen clamp (13). Remove hose (14) from pump (2).

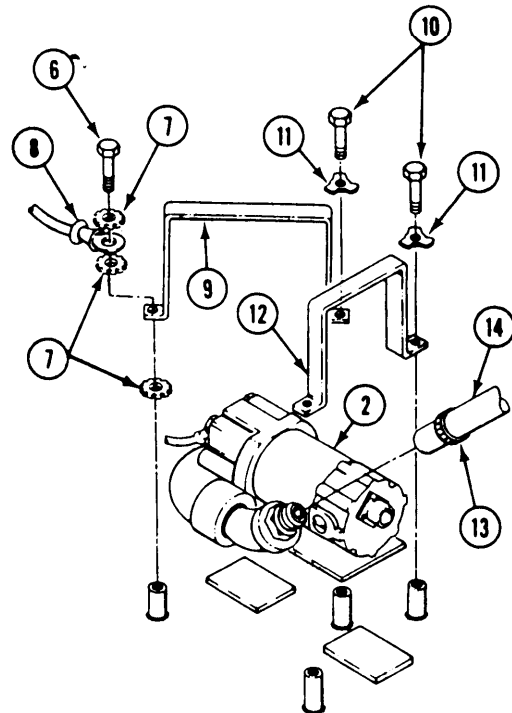

6. Remove adapter (1), elbow (2), screw (3), two lockwashers (4), and ground lead (5) from pump (6). Use adjustable wrench and pipe wrench. Discard lockwashers. Reinstall screw in pump.

INSTALL

7. Remove screw (3) and washer from new pump (6). Discard washer.
8. Install ground lead (5) on pump (6). Secure with two new lockwashers (4) and screw (3).
9. Apply sealing compound to external threads of elbow (2) and adapter (1).
10. Install elbow (2) and adapter (1) on pump (6). Use pipe wrench and adjustable wrench.

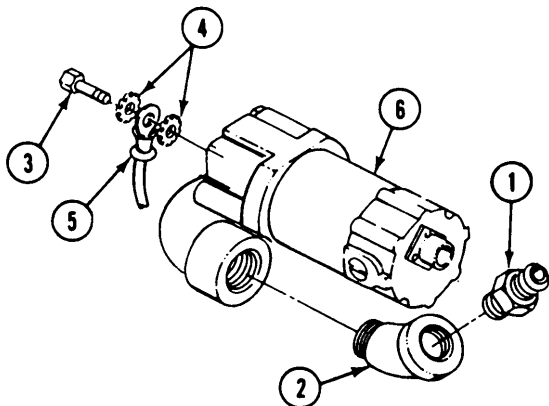

11. Cement new cushion (7) on bottom of pump (6) with adhesive.
12. Install pump (6) in carrier.

NOTE

Do not tighten strap screws until all four are installed.

13. Install strap (8) and ground lead (9) on hull weldnuts. Secure with three new lockwashers (10), screw (11), new key washer (12) and screw (13). Bend tabs on key washer.

14. Install strap (14) on hull weldnuts. Secure with two screws (13) and new key washers (12). Bend tabs on key washers.
15. Slide hose (15) on adapter (16). Secure with clamp (17).

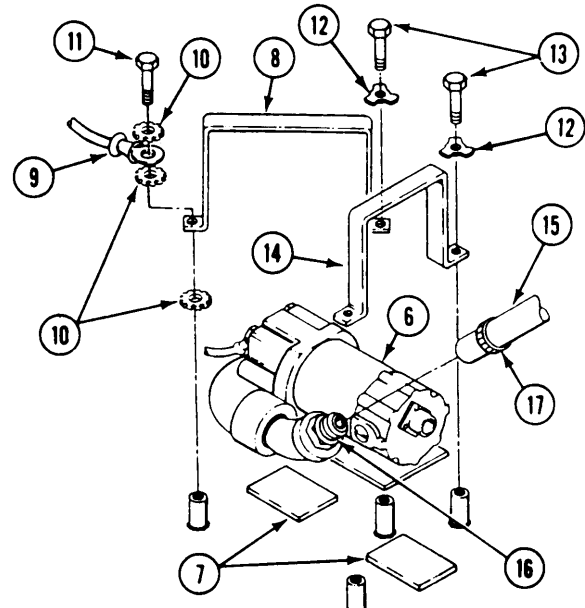

16. Install strainer (18) on hull weldnuts.
17. Connect lead (19) to bilge pump (6).
18. Secure strainer (18) to hull weldnuts with two new lockwashers (20), and screws (21).

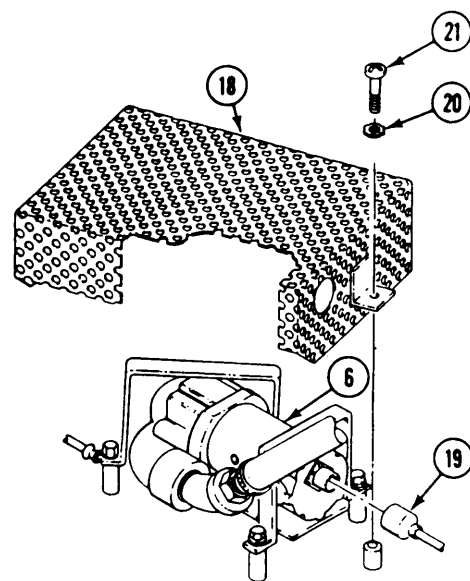

GO TO NEXT PAGE

FOLLOW-THROUGH STEPS

1. Connect battery ground lead (page 13-2).
2. Install hull front access cover (page 24-24).
3. Raise trim vane (see your -10).

END OF TASK

REPLACE FRONT BILGE PUMP PIPES

DESCRIPTION

This task covers: Remove (page 16-5). Install (page 16-6).

INITIAL SETUP

Tools:

General Mechanics Tool Kit (Item 30, App D)
Torque Wrench (Item 99, App D)
Socket Wrench Set (Item 88, App D)

Materials/Parts:

Gasket
Grommet
Self-locking nut (4)

Personnel Required:

Unit Mechanic

References:

See your -10

Equipment Conditions:

Engine stopped/shutdown (see your -10)
Carrier blocked (see your -10)
Trim vane lowered (see your -10)
Power plant front access door open
(see your -10)
Hull front access cover removed (page 24-24)
Front bilge pump strainer removed
(page 16-2, steps 1 and 2)

REMOVE

1. Remove two screws (1), washers (2), and clamps (3) from two bulkhead weldnuts.
2. Loosen four clamps (4). Remove lower pipe (5) from upper pipe (6) and bilge pump. Remove clamp (3), clamps (4), and two hoses (7) from pipe (5).
3. Loosen two clamps (8). Slide pipe (6) from discharge outlet and remove pipe from driver's compartment. Remove clamp (3), clamps (8), and hose (9) from pipe.
4. Remove grommet (10) from driver's compartment bulkhead. Discard grommet.
5. Remove four locknuts (11), washers (12), two U-bolts (13), sight glass (14), and gasket (15) from pipe (6). Discard gasket and locknuts.

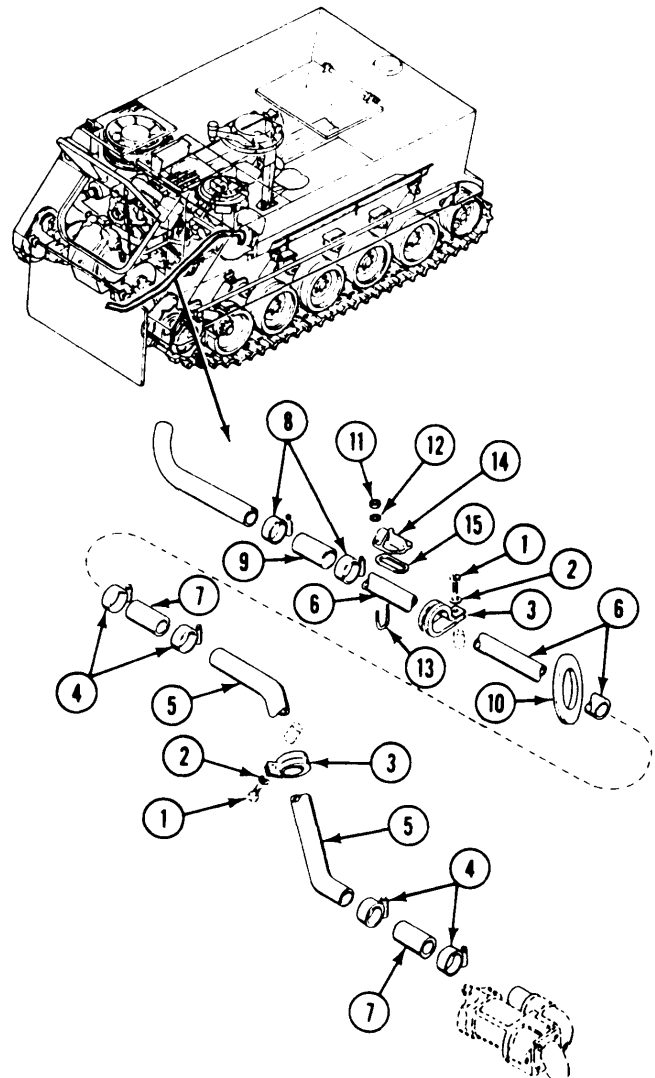

GO TO NEXT PAGE

INSTALL

6. Remove backing from new gasket (1). Install gasket, sticky side down, and sight glass (2) on upper pipe (3). Secure with two U-bolts (4), four washers (5), and new locknuts (6). Tighten nuts to 12 lb-in (1 N•m) torque. Use torque wrench and socket wrench set.
7. Install new grommet (7) in driver's compartment bulkhead.
8. Install clamp (8), hose (9), and two clamps (10) on upper pipe (3).
9. Slide pipe (3) through grommet (7) and install upper end on discharge outlet. Secure with two clamps (10).
10. Install clamp (8), two hoses (11), and four clamps (12) on lower pipe (13).
11. Slide pipe (13) on upper pipe (3) and bilge pump. Secure with four clamps (12).

12. Align two clamps (8) with two bulkhead weldnuts, Secure with two washers (14) and screws (15) .

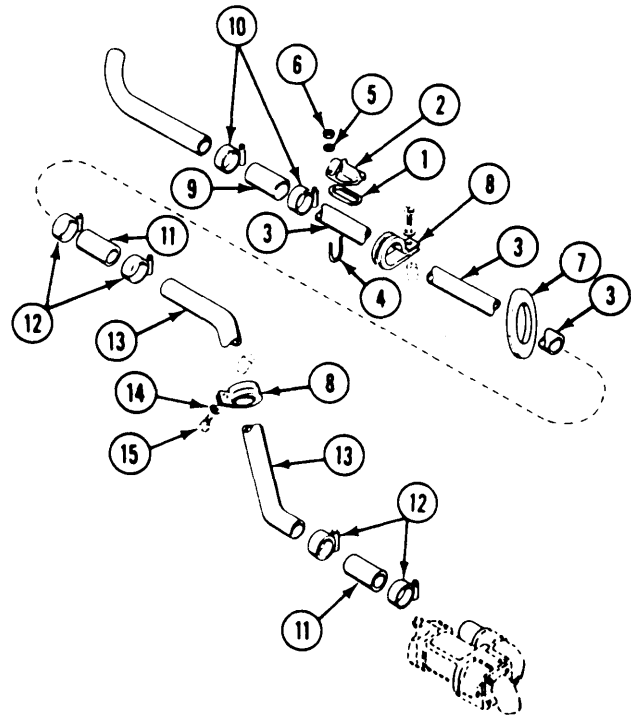

FOLLOW-THROUGH STEPS

- | | |
|---|--|
| <ol style="list-style-type: none"> 1. Install front bilge pump strainer (page 16-3, steps 15 thru 18). 2. Turn MASTER SWITCH ON (see your -10). Operate bilge pump and check for leaks. Turn all switches OFF (see your -10). | <ol style="list-style-type: none"> 3. Install hull front access cover (page 24-24). 4. Close power plant front access door (see your -10). 5. Raise trim vane (see your -10). |
|---|--|

END OF TASK

REPLACE FRONT BILGE VALVE

INITIAL SETUP

Tools:

General Mechanics Tool Kit (Item 30, App D)

Personnel Required:

Unit Mechanic

Materials/Parts:

Self-locking nut (3)

References:

See your -10

Equipment Conditions:

Engine stopped/shutdown (see your -10)

Ramp lowered (see your -10)

Driver's rear floor plate removed (page 24-44)

Personnel heater floor duct removed
(page 29-47 or 29-48)

Left front floor plate removed (page 24-40)

REMOVE

1. Remove three locknuts (1), six washers (2), and three screws (3) from hull cross beam (4). Discard locknuts.
2. Remove valve (5) from beam. Inspect valve,

CLEAN, INSPECT, AND REPLACE

3. Check valve, housing and fittings for cracks, leaks, and wear. Replace if needed.

INSTALL

4. Install valve (5) on hull cross beam (4).
5. Secure with three screws (3), six washers (2), and three new locknuts (1).

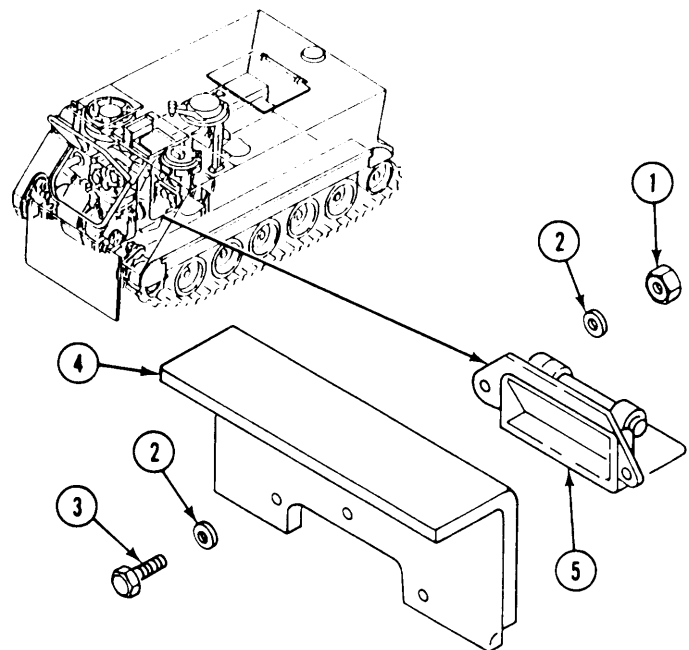

FOLLOW-THROUGH STEPS

1. Check for freedom of movement of valve after installation.
 2. Install left front floor plate (page 24-40).
 3. Install personnel heater floor duct (page 28-47 or 28-48).
 4. Install driver's rear floor plate (page 24-44).
 5. Raise and lock ramp (see your -10).
 6. Stop/shutdown engine (see your -10).
-

END OF TASK

REPLACE REAR BILGE PUMP AND STRAINER

DESCRIPTION

This task covers: Remove (page 16-8). Clean, Inspect and Replace (page 16-9).
Install (page 16-9).

INITIAL SETUP

Tools:

General Mechanics Tool Kit (Item 30, App D)
Adjustable Wrench (Item 80, App D)

Materials/Parts:

Dry cleaning solvent (Item 13, App C)
Sealing compound (Adhesive)
(Item 52, App C)
Key washer (3)
Lockwasher (5)
Self-locking nut

Personnel Required:

Unit Mechanic

References:

See your -10

Equipment Conditions:

Engine stopped/shutdown (see your -10)
Ramp lowered (see your -10)
Battery ground lead disconnected (page 13-2)
Rear floor plate removed (page 24-36)

REMOVE

1. Disconnect circuit 451 lead (1) from rear bilge pump (2).
- 2. On M106A2, M125A2, and M1064 only, remove screw (3), washer (4), and strainer (5) from pump (2).
3. Remove two screws (6), key washers (7), and bracket (8) from hull weldnuts. Discard washers.
4. Remove two screws (9), three lockwashers (10), key washer (11), ground lead (12), and bracket (13) from hull weldnuts. Discard lockwashers and key washers.
5. Loosen clamp (14). Remove pump (2) from hose (15) and cushion (16).
- 6. Remove strainer (17) (M106A2, M125A2, or M1064) or strainer (18) (all other carriers) from hull weldnuts.
7. Remove screw (19), two lockwashers (20), ground lead (12), and adapter (21) from pump (2). Use adjustable wrench. Discard lockwashers.
- 8. On M106A2, M125A2, and M1064 only, remove screw (22), locknut (24), and bracket (23) from pump (2). Discard locknut.

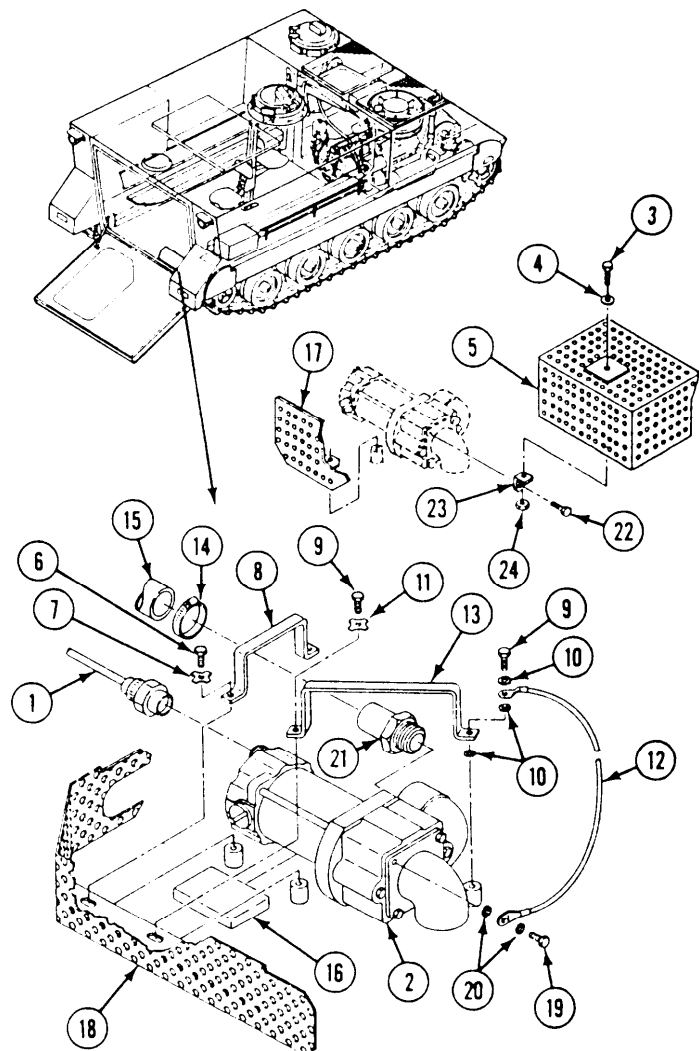

CLEAN, INSPECT AND REPLACE

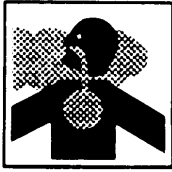

WARNING
 Dry cleaning solvent P-D-680 is toxic and flammable. Wear protective goggles and gloves; use only in well-ventilated area; avoid contact with skin, eyes, and clothes, and do not breathe vapors. Keep away from heat or flame. Never smoke when using solvent; the flash point for type I dry cleaning solvent is 100° F (38°C) and for type II is 138° F (50°C). Failure to do so may result in injury or death to personnel.

9. Clean pump and strainers with dry cleaning solvent.
10. Check cushion (1). Replace cushion that shows loss of resiliency.
11. Check bracket (2) for damage. Replace as needed.

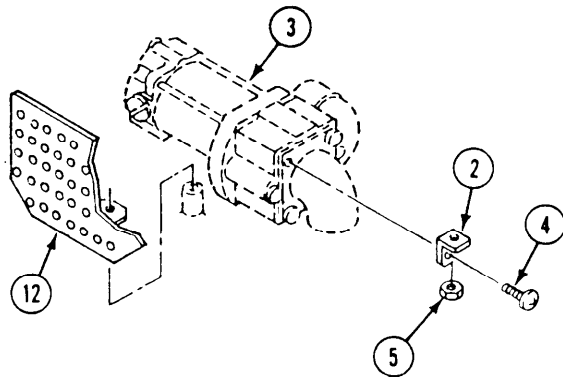

INSTALL

12. On M106A2, M125A2, and M1064 only, place bracket (2) on pump (3). Secure with screw (4) and new locknut (5).
13. Install adapter (6) in pump (3). Use adjustable wrench. Place ground lead (7) on pump. Secure with two new lockwashers (8) and screw (9).
14. Secure cushion (1) to pump (3) with adhesive.
15. Install pump (3) in carrier. Slide hose (10) on adapter (6) and secure with clamp (11).
16. Place strainer (12) (M106A2, M125A2, and M1064 only) or strainer (13) (all other carriers) on hull weldnuts.
17. Install bracket (14) on weldnuts.
18. Secure with three new lockwashers (15), ground lead (7), new key washer (16), and two screws (17).

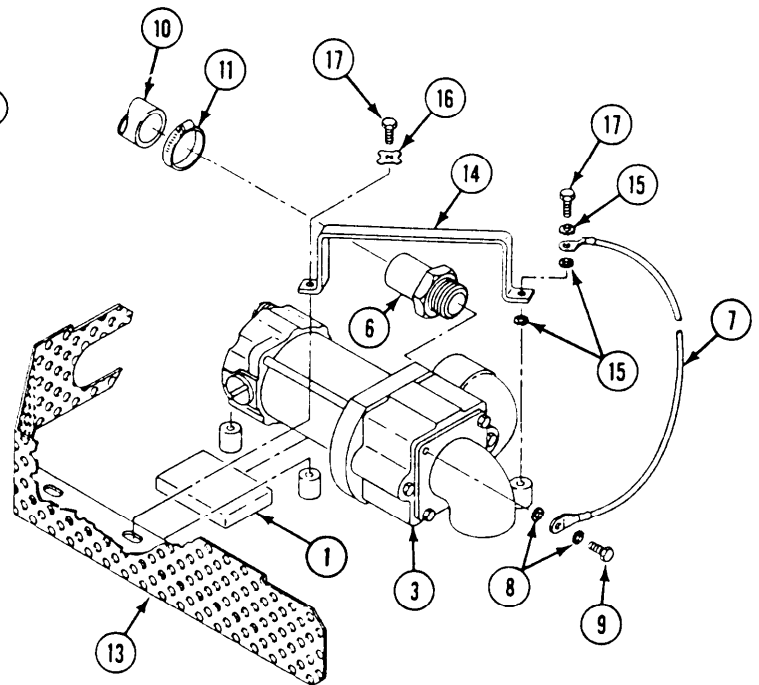

GO TO NEXT PAGE

19. Install bracket (1) on weldnuts. Secure with two new key washers (2) and screws (3).

■ 20. On M106A2, M125A2, and M1064 place strainer (4) on pump (5). Secure with washer (6) and screw (7).

21. Connect circuit 451 lead (8) to bilge pump (5).

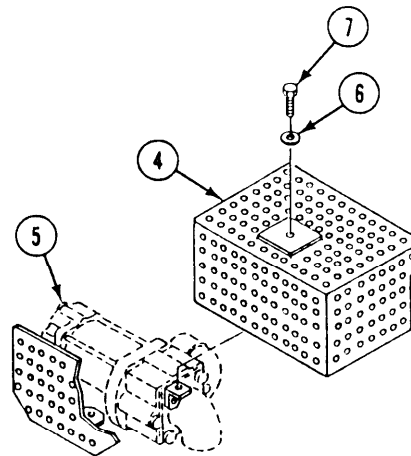
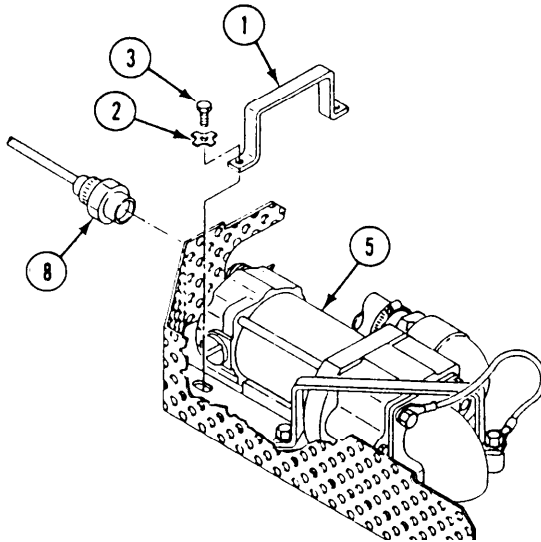

FOLLOW-THROUGH STEPS

1. Connect battery ground lead (page 13-2).
2. Turn MASTER SWITCH ON (see your -10).
3. Turn rear bilge pump switch on (see your -10) and check pump. Put your hand over pump outlet. You should feel air coming out. This means pump is working.
4. Turn rear bilge pump switch off (see your -10).
5. Raise and lock ramp (see your -10).
6. Stop/shutdown engine (see your -10).
7. Install rear floor plates (page 24-40).

END OF TASK

REPLACE REAR BILGE PUMP PIPES

INITIAL SETUP

Tools:

General Mechanics Tool Kit (Item 30, App D)

Materials/Parts:

Lockwasher (2)

Personnel Required:

Unit Mechanic

References:

See your -10

Equipment Conditions:

Engine stopped/shutdown (see your -10)

Ramp lowered (see your -10)

Rear floor plate removed (page 24-37)

REMOVE

1. Remove two screws (1), lockwashers (2), and clamps (3) from two bulkhead weldnuts. Discard lockwashers,
2. Loosen four clamps (4) and slide two hoses (5) back on pipe (6). Remove pipe from carrier.
3. Remove four clamps (4), two hoses (5), and two clamps (3) from pipe (6).

INSTALL

4. Install two clamps (3), hoses (5), and four clamps (4) on pipe (6).
5. Install pipe (6) in carrier and slide hoses (5) onto discharge tube (7) and bilge pump (8). Secure with four clamps (4).
6. Align two clamps (3) with bulkhead weldnuts. Secure with two new lockwashers (2) and screws (1).

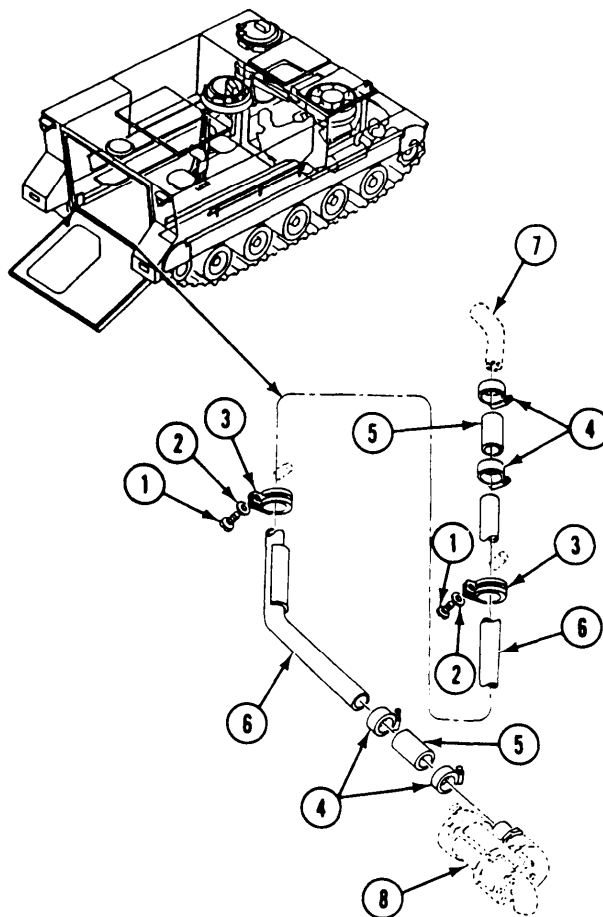

FOLLOW-THROUGH STEPS

1. Turn MASTER SWITCH ON (see your -10).
 2. Turn rear bilge pump switch ON (see your -10). Check pipe for leaks.
 3. Turn bilge pump switch OFF (see your -10).
 4. Turn MASTER SWITCH OFF (see your -10).
 5. Install rear floor plate (page 24-37).
-

END OF TASK

REPLACE BILGE PUMP CIRCUIT BREAKERS

DESCRIPTION

This task covers: Remove (page 16-12). Install (page 16-13).

INITIAL SETUP

Tools:

General Mechanics Tool Kit (Item 30, App D)

Reference:

see your -10

Materials/Parts:

Gasket
 Self-locking nut (8)
 Self-locking nut (4)

Equipment Conditions:

Engine stopped/shutdown (see your -10)
 Carrier blocked (see your -10)
 Battery ground lead disconnected (page 13-2)

Personnel Required:

Unit Mechanic

REMOVE

1. Remove eight screws (1), washers (2), and locknuts (3) from master switch panel (4) and distribution box (5). Pull master switch panel away from distribution box. Discard locknuts.
2. Disconnect circuit 450 lead (6) and circuit 450A lead (7) from front bilge pump circuit breaker (8).
3. Disconnect circuit 450B lead (9) and circuit 450C lead (10) from rear bilge pump circuit breaker (11).
4. Remove four locknuts (12), screws (13), and two circuit breakers (8 and 11) from distribution box (5). Discard locknuts,

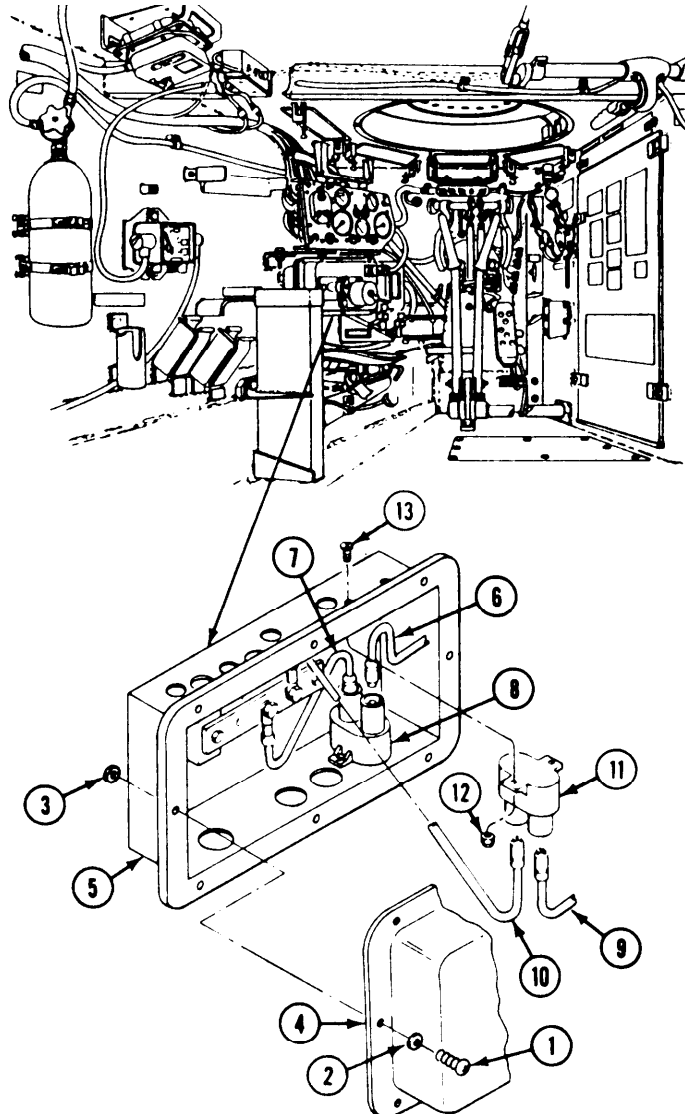

INSTALL

5. Place two circuit breakers (1 and 2) in distribution box (3). Secure with four screws (4) and new locknuts (5).
6. Connect circuit 450C lead (6) and circuit 450B lead (7) to top bilge pump circuit breaker (2).
7. Connect circuit 450A lead (8) and circuit 450 lead (9) to bottom bilge pump circuit breaker (1).
8. Inspect gasket (10). Replace if damaged.
9. Place master switch panel (11) on distribution box (3). Secure with eight screws (12), washers (13), and new locknuts (14).

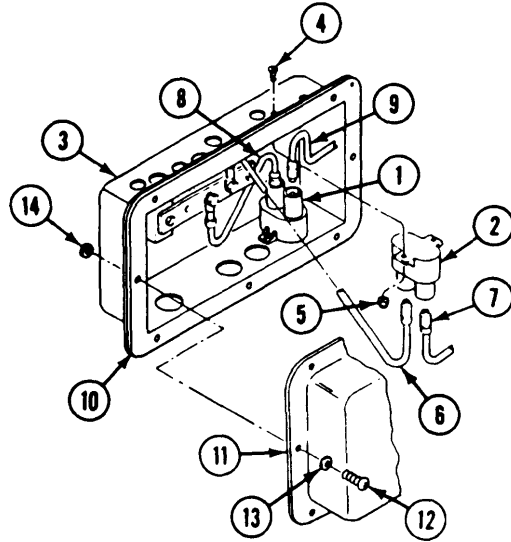
**FOLLOW-THROUGH STEPS**

1. Connect battery ground lead (page 13-2).
2. Turn MASTER SWITCH ON (see your -10).
3. Turn on bilge pump switches to check that bilge pump circuit breaker works properly (see your -10). Bilge pump lights should come on.
4. Turn all switches OFF (see your -10).

END OF TASK

CHAPTER 17
TRAILER HARNESS, RECEPTACLES, BLOWER, SWITCHES, AND
VENTILATION SYSTEM MAINTENANCE

Section I. TRAILER HARNESS

TASK INDEX

<u>Task</u>	<u>Page</u>	<u>Task</u>	<u>Page</u>
Replace Trailer Harness	17-2		

REPLACE TRAILER HARNESS

DESCRIPTION

This task covers: Remove (page 17-2). Clean, Inspect, and Repair (page 17-2).
Install (page 17-3).

INITIAL SETUP

Tools:

General Mechanics Tool Kit (Item 30, App D)
Digital Multimeter (Item 43, App D)

Materials/Parts:

Gasket
Lockwasher (2)

Personnel Required:

Unit Mechanic

References:

See your -10

Equipment Conditions:

Engine stopped/shutdown (see your -10)
Carrier blocked (see your -10)
Ramp raised (see your -10)
Rear floor plates removed (page 24-37)
Battery ground leads disconnected (page 13-2)

REMOVE

1. Disconnect rear wiring harness circuit 21, 22, 23, and 24 leads (1) from trailer wiring harness circuit 21, 22, 23, and 24 leads (2).
2. Remove shell connectors from leads (2) (page 14-9).
3. Remove screw (3), clamp (4), two lockwashers (5), circuit 90 lead (6) from hull weldnut. Discard lockwashers.
4. Remove four screws (7) and receptacle cover (8) from ramp. Carefully remove receptacle (9) with attached leads (2) and gasket (10) from ramp. Discard gasket.
5. If needed, remove connector (11) from rear bulkhead.
6. If needed, remove spring (12) and elbow (13) from ramp.

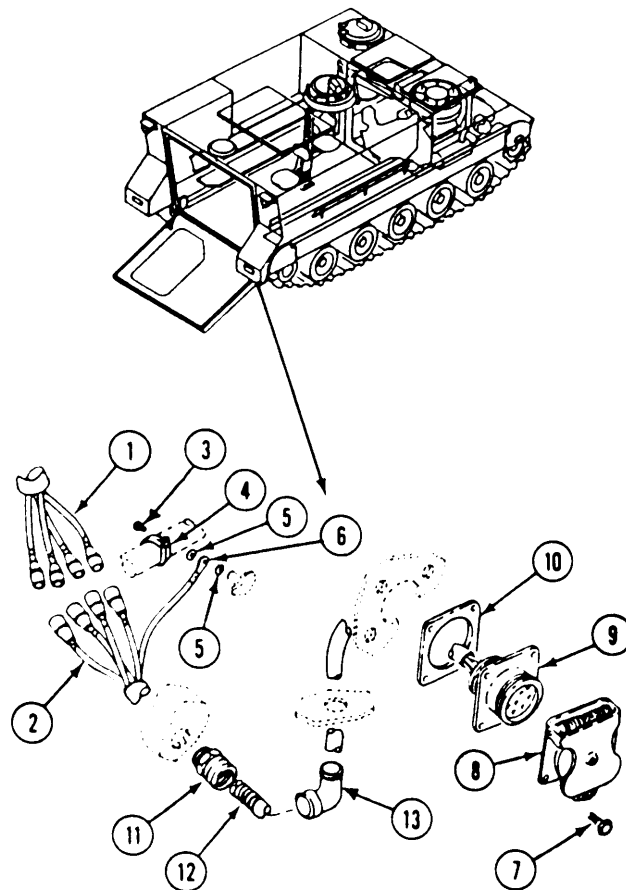

CLEAN, INSPECT, AND REPAIR

7. Check receptacle. Repair or replace cracked or broken receptacle (page 14-7).

INSTALL

8. If removed, install spring (1) and elbow (2) in ramp.
9. If removed, install connector (3) in rear bulkhead.
10. Route leads (4) through new gasket (5), and out through elbow (2).
11. Install gasket (5), receptacle (6), and cover (7) on ramp. Secure with four screws (8).
12. Route lead (4) through spring (1) and connector (3).
13. Install circuit 90 lead (9) between clamp (10) and weldnut on hull. Secure with two new lockwashers (11) and screw (12).
14. Install shell connectors on leads (4) (page 14-9).
15. Connect leads (4) to leads (13).

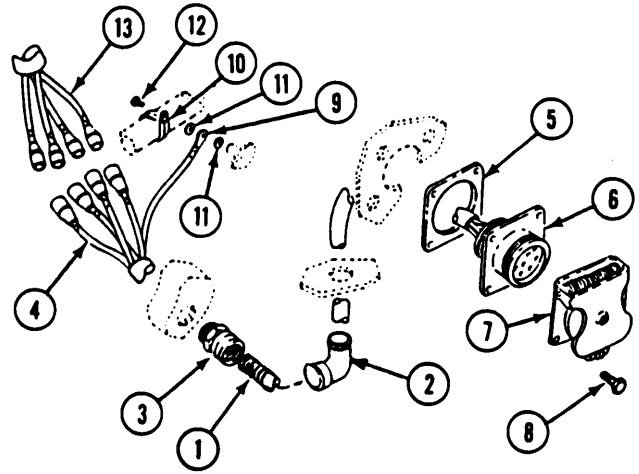

FOLLOW-THROUGH STEPS

1. Install rear floor plates (page 24-37).
2. Connect battery ground leads (page 13-2).
3. Turn MASTER SWITCH/BATTERY SWITCH ON (see your -10). Check with multimeter to make sure harness is installed properly.
4. Turn MASTER SWITCH/BATTERY SWITCH OFF (see your -10).

END OF TASK

Section II. COMMUNICATION AND UTILITY RECEPTACLES

TASK INDEX

<u>Task</u>	<u>Page</u>	<u>Task</u>	<u>Page</u>
■ Replace Utility Outlet Receptacle (All Except M577A2 and M1068)	17-5	Replace Rear Utility Receptacle Circuit Breakers (M577A2 and M1068 Only) 1.000....	17-11 ■
■ Replace Lead Assembly, Utility Outlet (M577A2 and M1068 only).. .	17-7	Replace Radiac Wire Harness (M113A2, M577A2, M1068, and M741A1 Only)	17-13 ■
Replace Telepost and Cover	17-8		
■ Replace Rear Utility Outlet Receptacles (M577A2 and M1068 Only).	17-9		

REPLACE UTILITY OUTLET RECEPTACLE (ALL EXCEPT M577A2 AND M1068)

DESCRIPTION

This task covers: Remove (page 17-5). Clean, Inspect, and Replace (page 17-5).
Install (page 17-6).

INITIAL SETUP

Tools:

General Mechanics Tool Kit (Item 30, App D)
Digital Multimeter (Item 43, App D)

Materials/Parts:

Lockwasher (2)
Self-locking nut (8)

Personnel Required:

Unit Mechanic

Reference:

See your -10

Equipment Conditions:

Engine stopped/shutdown (see your -10)
Carrier blocked (see your -10)
Battery ground lead disconnected (page 13-2)
Warning light panel assembly removed (page 11-25)

REMOVE

1. Disconnect circuit 37 lead (1) from utility outlet receptacle lead (2).
2. Slide shell connector (3) down lead (2). Remove slotted washer (4) from lead. Remove shell connector from lead.
3. Remove eight locknuts (5), washers (6), screws (7), and master switch panel (8) from distribution box (9). Discard locknuts.

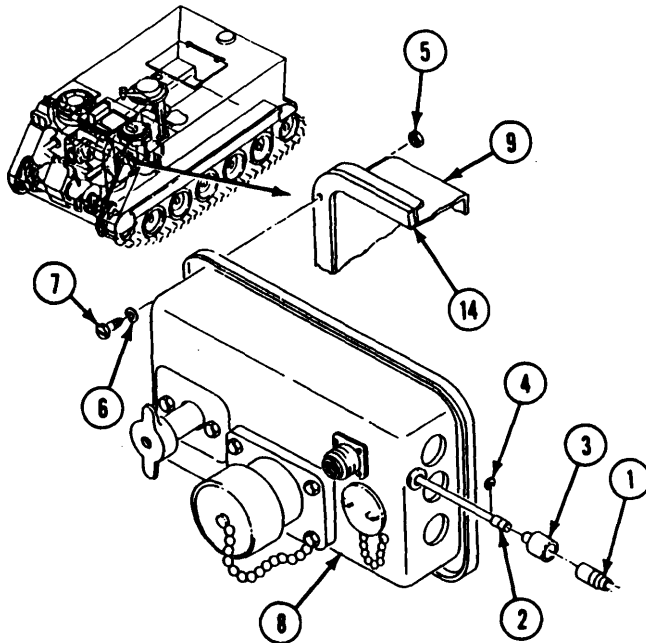

4. Remove two screws (10), lockwashers (11), and receptacle (12) from master switch panel (8). Discard lockwashers.
5. If needed, remove grommet (13) from master switch panel (8).

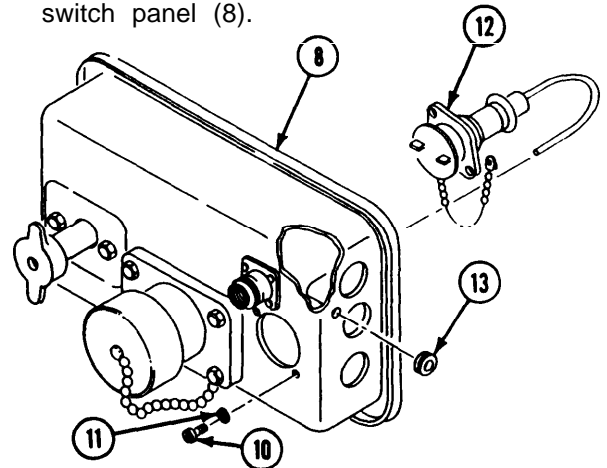

CLEAN, INSPECT, AND REPLACE

6. Check connectors. Replace cracked or broken connector (page 14-3).
7. Inspect gasket (14). Replace if damaged.

GO TO NEXT PAGE

INSTALL

8. If removed, install new grommet (1) in master switch panel (2).

NOTE

Make sure receptacle cover retainer chain is installed on lower screw.

- 9 Place utility outlet receptacle (3) on rear of master switch panel (2). Secure with two new lockwashers (4) and screws (5).
10. Route utility outlet receptacle lead (6) through grommet (1). Install shell connector (7) and slotted washer (8).

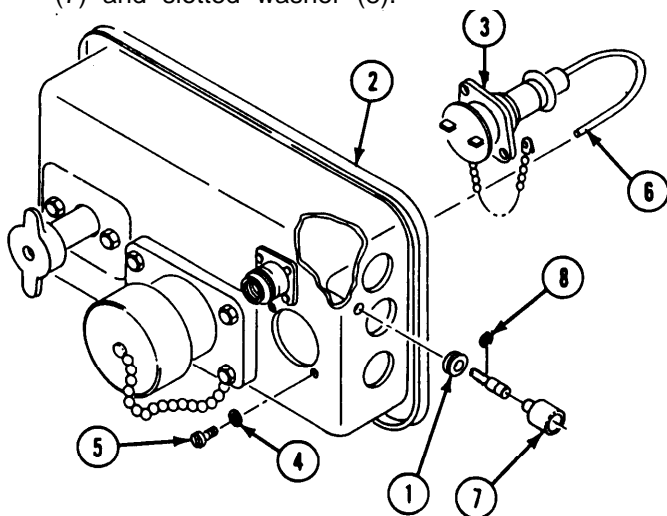

11. Install master switch panel (2) on distribution box (9). Secure with eight screws (10), washers (11), and new locknuts (12).
12. Connect circuit 37 lead (13) to utility receptacle lead (14).

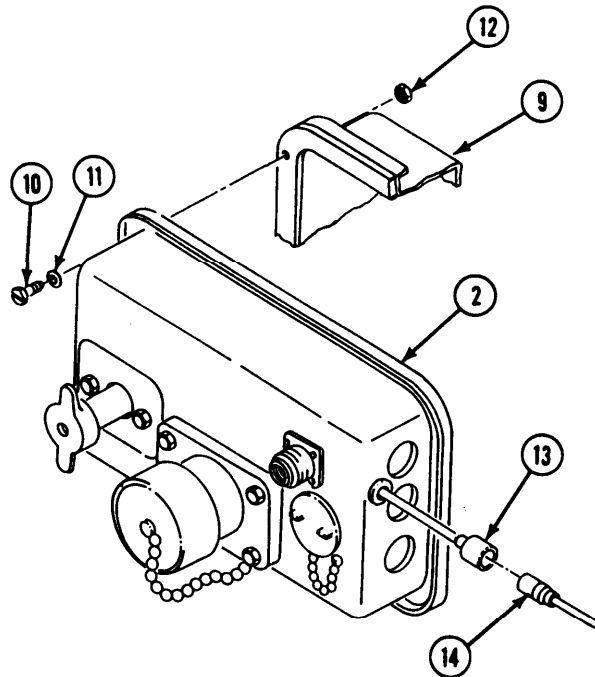

FOLLOW-THROUGH STEPS

1. Install warning light panel assembly (page 11-25).
2. Connect battery ground lead (page 13-2).
3. Turn MASTER SWITCH ON (see your -10) to check that receptacle is installed properly. Use multimeter.
4. Turn MASTER SWITCH OFF see your -10).

END OF TASK

REPLACE LEAD ASSEMBLY, UTILITY OUTLET (M577A2 AND M1068 ONLY)

INITIAL SETUP

Tools:

- General Mechanics Tool Kit (Item 30, App D)
- Digital Multimeter (Item 43, App D)

Personnel Required:

Unit Mechanic

References:

see your -10

Equipment Conditions:

Engine stopped/shutdown (see your -10)
Battery ground leads disconnected (page 13-2)

REMOVE

1. Disconnect lead assembly (1) from circuit 37 lead (2) at master switch panel (3).
2. Disconnect lead assembly (1) from circuit 38 lead (4) at instrument panel (5). Remove lead assembly.

CLEAN, INSPECT, AND REPLACE

3. Check lead continuity Use digital multimeter. Replace bad lead.
4. Check connectors. Replace cracked or broken connectors (page 14-1).

INSTALL

NOTE

Lead assembly (1) is banded as circuit 37 at master switch panel and circuit 38 at instrument panel. Make sure it is installed properly.

5. Connect lead assembly (1) to circuit 38 lead (4) at instrument panel (5).
6. Connect lead assembly (1) to circuit 37 lead (2) at master switch panel (3).

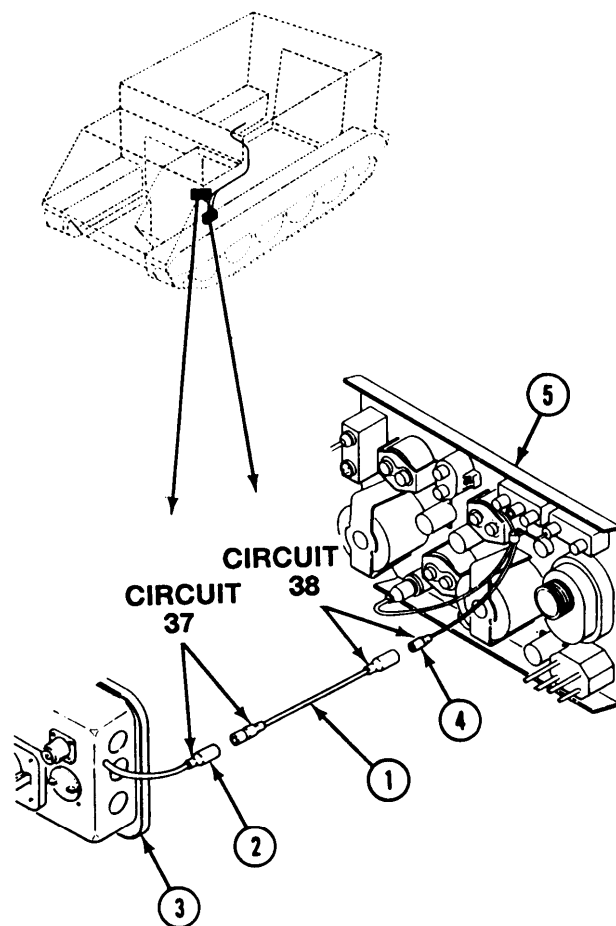

FOLLOW-THROUGH STEPS

1. Connect battery ground leads (page 13-2).
2. Turn MASTER SWITCH ON to check that lead assembly is installed properly. Turn MASTER SWITCH OFF (see your -10).

END OF TASK

REPLACE TELEPOST AND COVER

INITIAL SETUP

Tools:

General Mechanics Tool Kit (Item 30, App D)

References:

see your -10

Materials/Parts:

Gasket (8)

Equipment Conditions:

Engine stopped (see your -10)

Carrier blocked (see your -10)

Ramp lowered (see your -10)

Personnel Required:

Unit Mechanic

REMOVE

1. Remove two screws (1), retainer strip (2), and rubber shield (3) from hull mount.
2. Remove eight teleposts (4), washers (5), and gaskets (6) from four posts (7). Discard gaskets.
3. Remove four posts (7) and insulators (8) from hull.

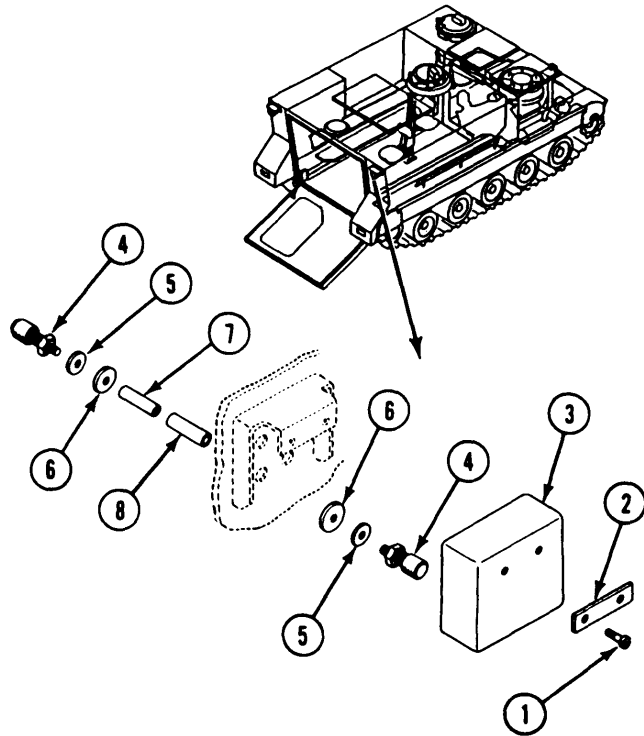

INSTALL

4. Install four insulators (8) and posts (7) in hull.
5. Install eight new gaskets (6), washers (5), and teleposts (4) on each end of four posts (7).
6. Install rubber shield (3) on hull mount. Secure with retainer strip (2) and two Screws (1).

FOLLOW-THROUGH STEPS

1. Start engine. Raise and lock ramp (see your -10).
2. Stop engine (see your -10).

END OF TASK

REPLACE REAR UTILITY OUTLET RECEPTACLES (M577A2 AND M1068 ONLY)

DESCRIPTION

This task covers: Remove (page 17-9). Clean, Inspect, and Replace (page 17-9).
Install (page 17-10).

INITIAL SETUP

Tools:

General Mechanics Tool Kit (Item 30, App D)

References:

See your -10

Materials/Parts:

Lockwasher (5)
Receptacle gasket

Equipment Conditions:

Engine stopped/shutdown (see your -10)
Ramp lowered (see your -10)
Carrier blocked (see your -10)
Battery ground lead disconnected (page 13-2)

Personnel Required:

Unit Mechanic

REMOVE

1. Remove two screws (1) retainer strip (2) and rubber shield (3) from hull mount (4).
2. Disconnect circuit 37A lead (5) (right receptacle) or circuit 37B lead (5) (left receptacle) from receptacle lead (6).
3. Remove clip (7) and rear main wiring harness (8) from cradle (9).
4. Remove screw (10), cradle (9), ground lead (11), and lockwasher (12) from hull weldnut. Discard lockwasher.
5. Remove four screws (13), lockwashers (14), chain (15), receptacle (16), and gasket (17) from rear bulkhead. Discard gasket and lockwashers.
6. Remove cap (18) from receptacle (16).

CLEAN, INSPECT, AND REPLACE

7. Check leads. Replace frayed, cracked, or broken leads (page 14-3).
8. Check connectors. Replace cracked or broken connectors (page 14-3).

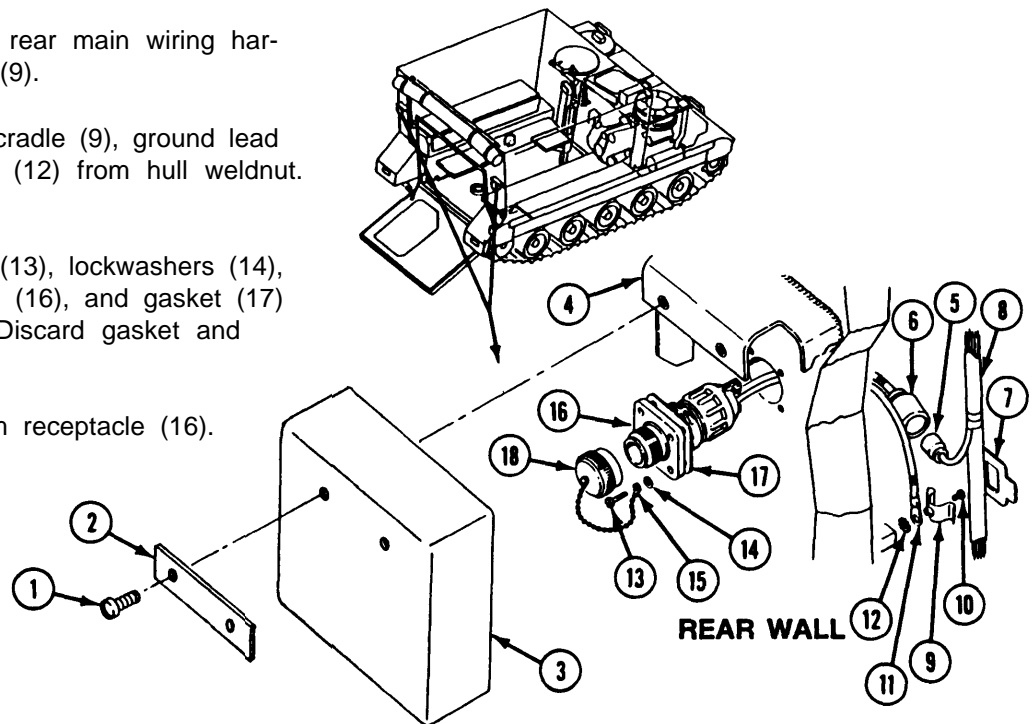

GO TO NEXT PAGE

INSTALL

9. Install cap (1) on receptacle (2).
10. Place new gasket (3) and receptacle (2) on rear bulkhead. Secure with four new lockwashers (4) and screws (5) with chain (6) under head of one screw.
11. Install ground lead (7) and cradle (8) on hull weldnut. Secure with new lockwasher (9) and screw (10).
12. Place rear main wiring harness (11) in cradle (8). Secure with clip (12).
13. Connect receptacle lead (13) to circuit 37A lead (14) (right receptacle) or circuit 37B lead (14) (left receptacle).
14. Install rubber shield (15) on hull mount (16). Secure with retainer strip (17) and two screws (18).

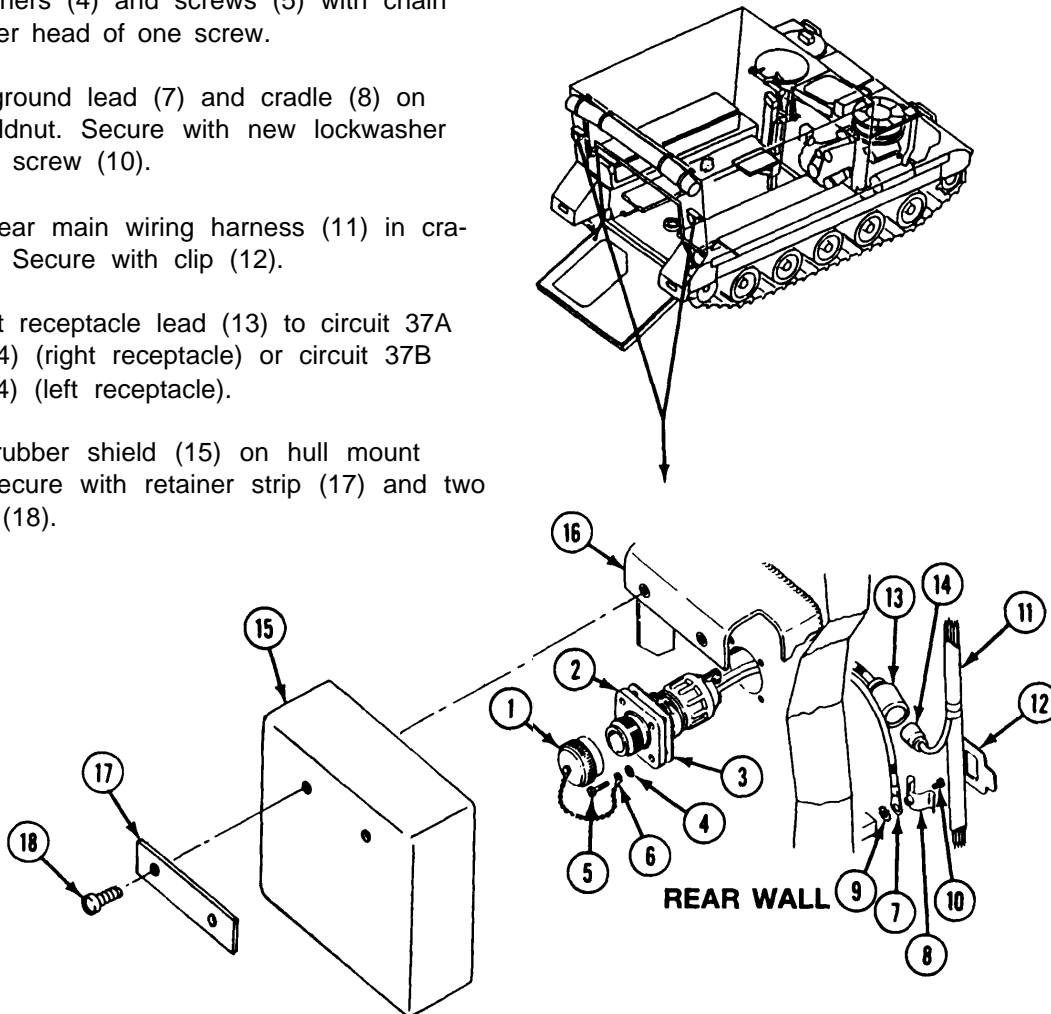

FOLLOW-THROUGH STEPS

- | | |
|--|--|
| <ol style="list-style-type: none"> 1. Connect battery ground leads (page 13-2). 2. Turn MASTER SWITCH ON to check that receptacle is installed properly. | <ol style="list-style-type: none"> 3. Start engine. Raise and lock ramp (see your -10). 4. Stop engine (see your -10). |
|--|--|

END OF TASK

REPLACE REAR UTILITY RECEPTACLE CIRCUIT BREAKERS (M577A2 AND M1068 ONLY)

DESCRIPTION

This task covers: Remove (page 17-11). Clean, Inspect, and Replace (page 17-12).
Install (page 17-12).

INITIAL SETUP

Tools:

General Mechanics Tool Kit (Item 30, App D)

Materials/Parts:

Self-locking nut (8)

Personnel Required:

Unit Mechanic

References:

See your -10

Equipment Conditions:

Engine stopped (see your -10)

Carrier blocked (see your -10)

Battery ground lead disconnected (page 13-2)

REMOVE

NOTE

If you want to remove only the left circuit breaker, skip Step 3. If you want to remove only the right circuit breaker, skip step 2.

1. Remove eight locknuts (1), washers (2), screws (3), and panel (4) from distribution box (5). Discard locknuts.
- 2* Disconnect circuit 10 lead (6) and circuit 37A lead (7) from left circuit breaker (8).
3. Disconnect circuit 37B lead (9) and circuit 10 lead (10) from right circuit breaker (11).
4. Remove two nuts (12), screws (13), and circuit breakers (8 and 11) from distribution box (5).

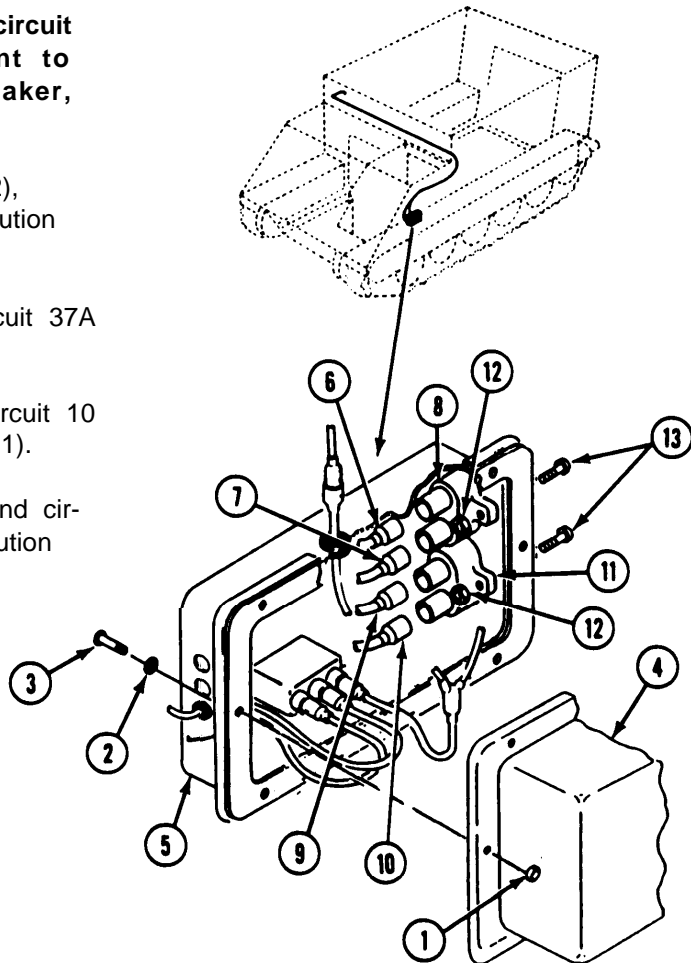

GO TO NEXT PAGE

CLEAN, INSPECT, AND REPLACE

5. Check leads. Replace frayed, cracked, or broken leads (page 14-3).
6. Check connectors. Replace cracked or broken connectors (page 14-3).
7. Inspect gasket on flange of distribution box. Replace if damaged.

10. Connect circuit 10 lead (6) and circuit 37A lead (7) to circuit breaker (1).
11. Connect circuit 37B lead (8) and circuit 10 lead (9) to circuit breaker (5).
12. Place panel (10) on distribution box (2). Secure with eight screws (11), washers (12), and new locknuts (13).

INSTALL

8. Place circuit breaker (1) in distribution box (2). Secure with two screws (3) and nuts (4).
9. Place circuit breaker (5) in distribution box (2). Secure with two screws (3) and nuts (4).

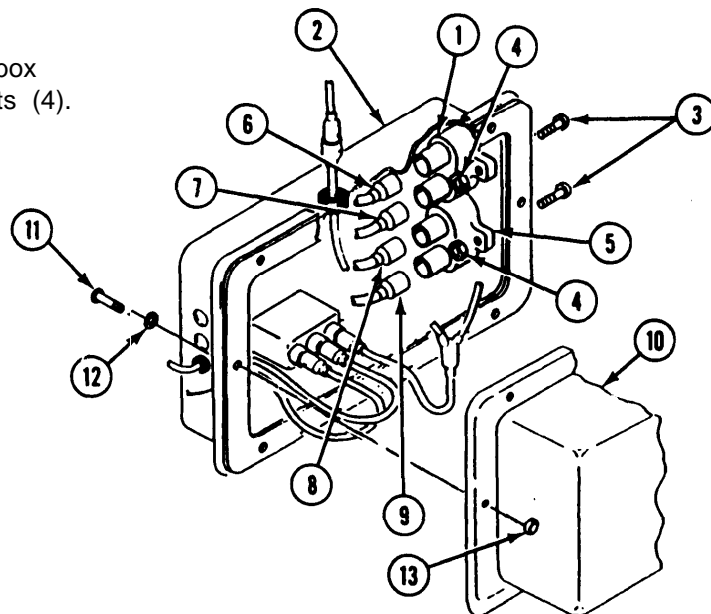

FOLLOW-THROUGH STEPS

1. Connect battery ground lead (page 13-2).
2. Turn MASTER SWITCH ON. Check for power at utility outlet receptacles (page 3-122).
3. Turn MASTER SWITCH OFF (see your -10).

END OF TASK

REPLACE RADIAC WIRE HARNESS (M113A2, M577A2, M1068, AND M741A1 ONLY)

INITIAL SETUP

Tools:

General Mechanics Tool Kit (Item 30, App D)

References:

See your -10

Materials/Parts:

12 ft Cord

Equipment Conditions:

Engine Stopped/shutdown (see your -10)
Battery ground lead disconnected (page 13-2)

Personnel Required:

Unit Mechanic

REMOVE

1. Remove four clips (1) and RADIAC harness (2) from four cradles (3).
2. Remove electrical connector(s) (4) from end of harness (2) (page 14-3).
3. Tie 12-foot (3.7 m) cord to harness (2).
4. Pull harness (2) and cord through channel. Untie cord from harness (2), leaving cord in channel.

8. Place harness (2) on four cradles (3) and secure with four clips (1).

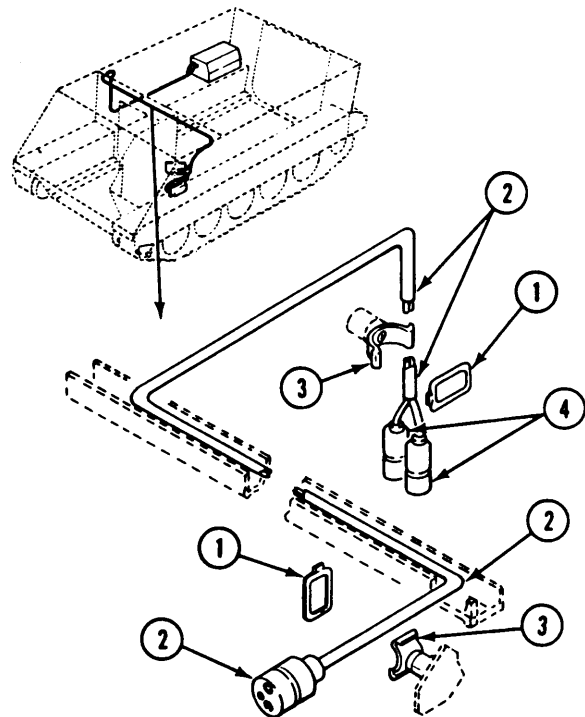

INSTALL

5. Tie cord to end of wiring harness (2).
 6. Pull cord and harness (2) through channel. Remove cord.
 7. Install connector(s) (4) on harness (2) (page 14-3).
-

FOLLOW-THROUGH STEPS

1. Connect battery ground lead (page 13-2).
-

END OF TASK

Section III. REAR COMPARTMENT BLOWER AND FUEL QUANTITY SELECTOR SWITCH (M577A2 AND M1068 ONLY)

TASK INDEX

<u>Task</u>	<u>Page</u>	<u>Task</u>	<u>Page</u>
Replace Compartment Blower (M577A2 and M1068 Only)	17-15	Replace Fuel Quantity Selector Switch (M577A2 and M1068 Only) . . .	17-17
Replace Blower Switch (M577A2 and M1068 Only)	17-16		

REPLACE COMPARTMENT BLOWER (M577A2 AND M1068 ONLY)

INITIAL SETUP**Tools:**

General Mechanics Tool Kit (Item 30, App D)

Materials/Parts:

Self-locking nut (6)
Self-locking nut (3)

Personnel Required:

Unit Mechanic

References:

See your -10

Equipment Conditions:

Engine stopped (see your -10)
Battery ground lead disconnected (page 13-2)
Power plant rear access panel removed
(page 24-29)

REMOVE

1. Disconnect blower lead (1) from circuit 59 lead (2).
2. Remove six locknuts (3), washers (4), screws (5), and adapter (6) with blower (7) attached, from flapper valve (8). Discard locknuts.
3. Remove three locknuts (9), screws (10), and adapter (6) from blower (7). Discard locknuts.

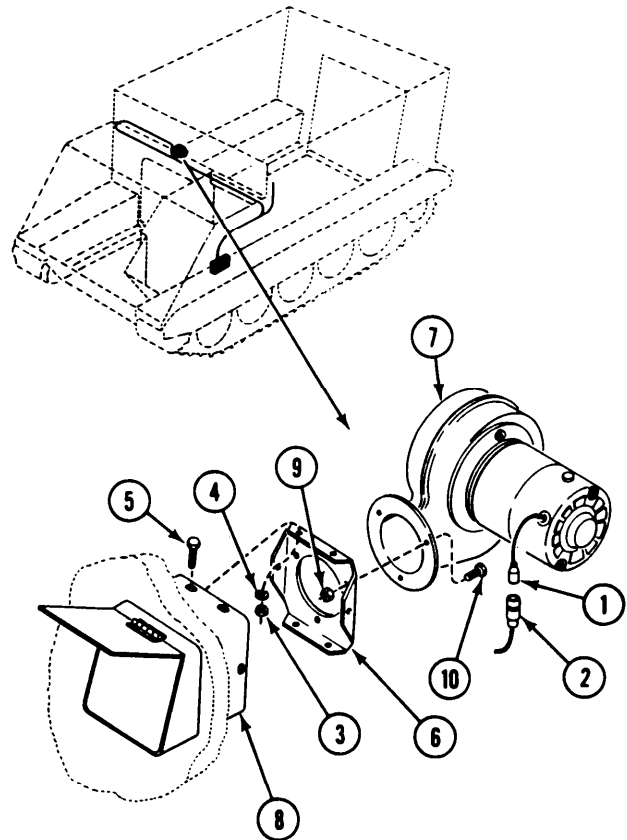
**CLEAN, INSPECT, AND REPLACE**

4. Check adapter (6). Replace cracked adapter.

INSTALL

5. Place adapter (6) on blower (7). Secure with three screws (10) and new locknuts (9).
6. Place adapter (6), with blower (7) attached, on flapper valve (8). Secure with six screws (5), washers (4), and new locknuts (3).
7. Connect circuit 59 lead (2) to blower lead (1).

FOLLOW-THROUGH STEPS

1. Connect battery ground lead (page 13-2).
 2. Turn MASTER SWITCH and blower switch ON to check that blower operates properly (see your -10).
 3. Turn all switches OFF (see your -10).
 4. Install power plant rear access panel (page 24-29).
-

END OF TASK

REPLACE BLOWER SWITCH (M577A2 AND M1068 ONLY)

INITIAL SETUP

Tools:

General Mechanics Tool Kit (Item 30, App D)

References:

See your -10

Materials/Parts:

Self-locking nut (8)

Equipment Conditions:

Engine stopped (see your -10)

Battery ground lead disconnected (page 13-2)

Personnel Required:

Unit Mechanic

REMOVE

1. Remove eight locknuts (1), washers (2), screws (3), and master switch panel (4) from distribution box (5). Discard locknuts.
2. Disconnect two circuit 59 leads (6) from rear of blower switch (7).
3. Remove two screws (8) and switch (7) from panel (4).
4. Inspect gasket (9). Replace if damaged.

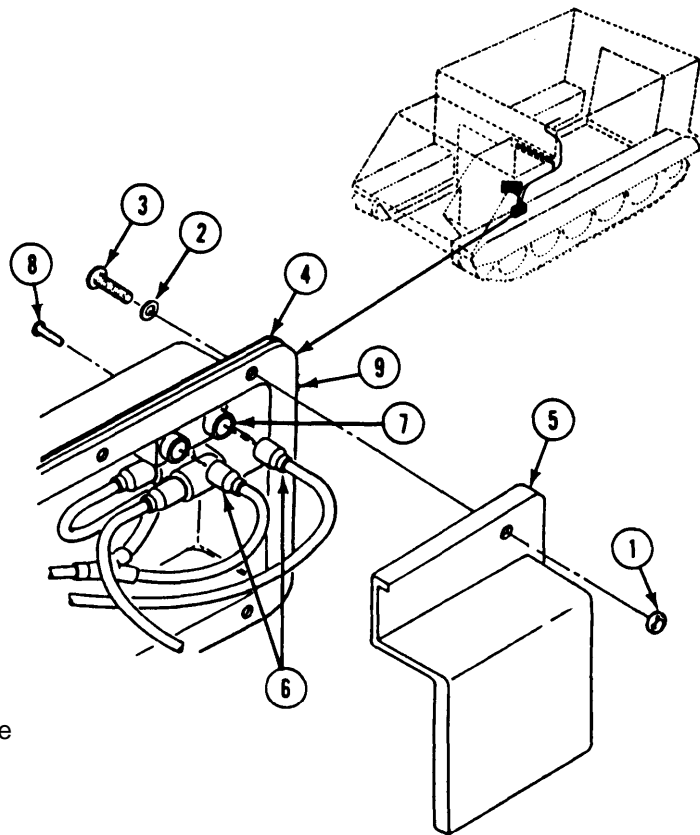

INSTALL

5. Place switch (7) on rear of master switch panel (4). Secure with two screws (8).
6. Connect two circuit 59 leads (6) to rear of switch (7).
7. Place panel (4) on distribution box (5). Secure with eight screws (3), washers (2), and new locknuts (1).

FOLLOW-THROUGH STEPS

1. Connect battery ground lead (page 13-2).
2. Turn MASTER SWITCH ON. Turn blower switch ON. Blower should run. Turn all switches OFF' (see your -10).

END OF TASK

REPLACE FUEL QUANTITY SELECTOR SWITCH (M577A2) AND M1068 ONLY

INITIAL SETUP

Tools:

General Mechanics Tool Kit (Item 30, App D)

Materials/Parts

Self-locking nut (8)

Personnel Required:

Unit Mechanic

References:

See your -10

Equipment Conditions:

Engine stopped (see your -10)

Battery ground lead disconnected (page 13-2)

REMOVE

1. Remove eight locknuts (1), washers (2), screws (3), and master switch panel (4) from distribution box (5). Discard locknuts.
2. Disconnect circuit 28 (6), circuit 29 (7), and circuit 30 (8) leads from rear of fuel quantity selector switch (9).
3. Remove two screws (10) and switch (9) from panel (4).
4. Inspect gasket (11). Replace if damaged.

INSTALL

5. Place switch (9) on rear of master switch panel (4). Secure with two screws (10).
6. Connect circuit 30 (8), circuit 29 (7), and circuit 28 (6) leads to rear of switch (9).
7. Place panel (4) on distribution box (5). Secure with eight screws (3), washers (2), and new locknuts (1).

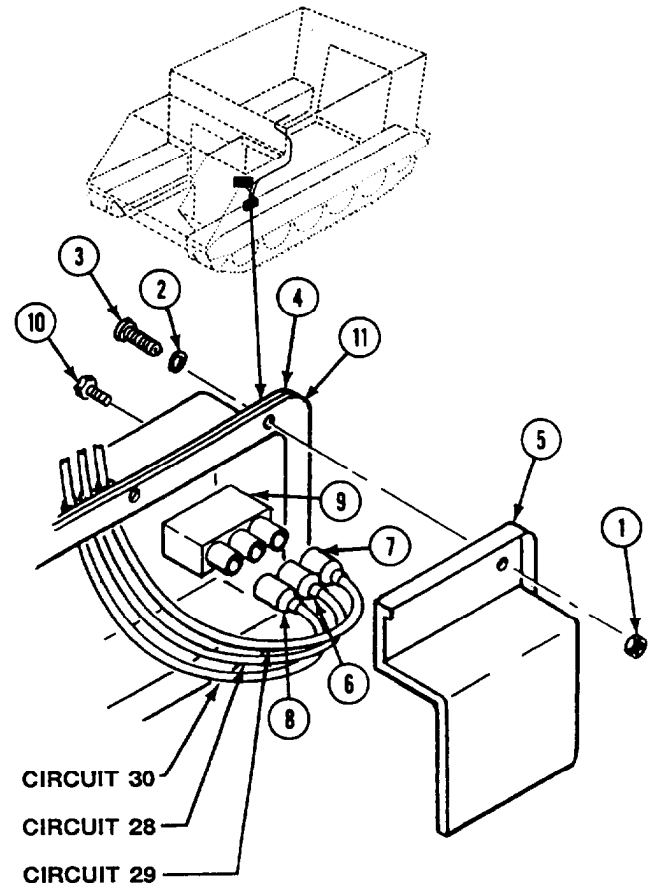

FOLLOW-THROUGH STEPS

1. Connect battery ground leads (page 13-2).
2. Turn MASTER SWITCH ON. Check for fuel quantity readings on both tanks. Turn all switches OFF (see your -10).

END OF TASK

CHAPTER 18
TRANSMISSION RELATED COMPONENTS MAINTENANCE

TASK INDEX

<u>Task</u>	<u>Page</u>	<u>Task</u>	<u>Page</u>
Replace Transmission To Oil Cooler Hose And Fittings	18-2	Replace Transmission Vent And Filler Tube	18-6
Replace Oil Cooler To Transmission Hose And Fittings	18-4	Replace Transmission Oil Filter And Drain	18-8

REPLACE TRANSMISSION TO OIL COOLER HOSE AND FITTINGS

DESCRIPTION

This task covers: Remove (page 18-2). Clean, Inspect, and Replace (page 18-3).
Install (page 18-3).

INITIAL SETUP

Tools:

General Mechanics Tool Kit (Item 30, App D)
Adjustable Wrench (Item 80, App D)
Pipe Wrench (Item 86, App D)

Materials/Parts:

Dry cleaning solvent (Item 13, App C)
Sealing compound (Item 51, App C)
Key washer (2)
Preformed packing
Self-locking nut
Suitable container

Personnel Required:

Unit Mechanic

References:

See your -10
See your LO

Equipment Conditions:

Power plant removed (page 5-11)

REMOVE

1. Remove screw (1), key washer (2), two clamps (3), and two hoses (4 and 5) from transmission (6). Discard key washer.
2. Remove screw (7), locknut (8), clamp (9), and two hoses (4 and 5) from bracket (10). Discard locknut.
3. Disconnect hose (4) from elbow (11). Place hose through hull access opening. Drain oil from cooler and hose into container.
4. Disconnect hose (4) from elbow (12).
5. Remove elbow (12) from tee (13).
6. Disconnect circuit 327 lead (14) from transmission high oil temperature switch (15).
7. Remove switch (15) from tee (13).
8. Remove tee (13) from bushing (16).
9. Remove bushing (16) from oil cooler (17). Use pipe wrench.
10. Remove elbow (11) from transmission (6).

11. Remove preformed packing (18) from elbow (11). Discard packing.

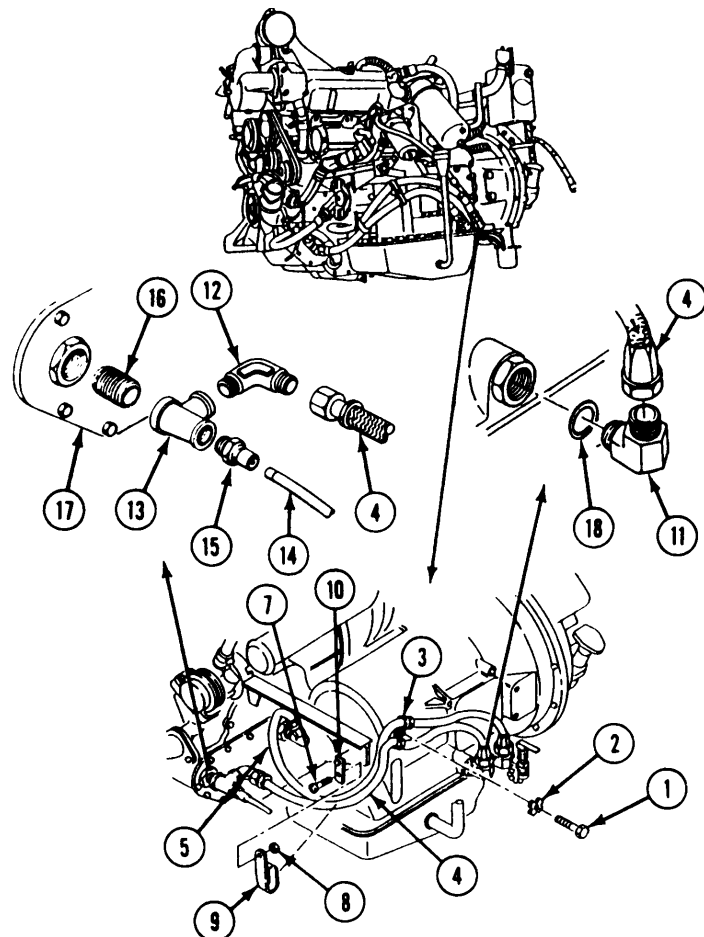

CLEAN, INSPECT, AND REPLACE



WARNING
 Dry cleaning solvent is flammable. Keep it away from heat or open flame. Use in well ventilated area. Do not let it get on your skin.

12. Clean hose and fittings with dry cleaning solvent.
13. Check hose. Replace broken, twisted, or worn hose.
14. Check fittings. Replace fittings that are cracked or have stripped threads.

INSTALL

15. Apply a thin even coat of sealing compound to cleaned external threads of fittings before installation.
16. Install new preformed packing (1) on elbow (2). Tighten jamnut (3). Use adjustable wrench.
17. Install elbow (2) in transmission (4).
18. Install bushing (5) in oil cooler (6). Use pipe wrench.
19. Install tee (7) on bushing (5).
20. Install elbow (8) on tee (7).
21. Install transmission high oil temperature switch (9) in tee (7).
22. Connect circuit 327 lead (10) to switch (9).
23. Connect hose (11) to two elbows (2 and 8).

24. Install two hoses (11 and 12) on bracket (13). Secure with clamp (14), two screws (15), and new locknut (16).
25. Install two hoses (11 and 12) on transmission (4). Secure with two clamps (17), screw (18), and new key washer (19).
26. Check transmission oil level (see your LO).



WARNING
 Carbon monoxide is poisonous and can kill you. Do not idle engine with bottom access cover and power plant access panels off unless there is ADEQUATE VENTILATION.

27. Start engine (see your -10). Check for leaks.

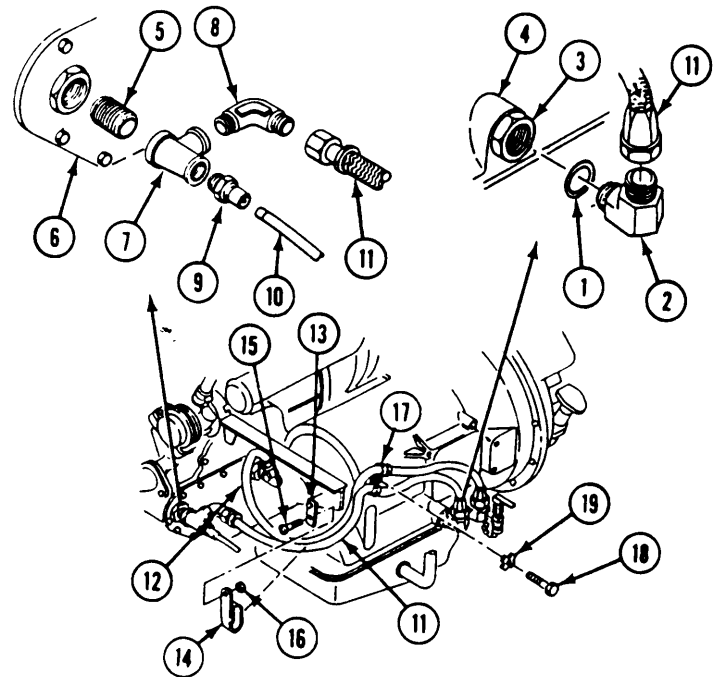

FOLLOW-THROUGH STEPS

1. Power plant installed (page 5-11).

END OF TASK

REPLACE OIL COOLER TO TRANSMISSION HOSE AND FITTINGS

DESCRIPTION

This task covers: Remove (page 18-4). Clean, Inspect, and Replace (page 18-5).
Install (page 18-5).

INITIAL SETUP

Tools:

General Mechanics Tool Kit (Item 30, App D)
Adjustable Wrench (Item 80, App D)

Materials/Parts:

Dry cleaning solvent (Item 13, App C)
Sealing compound (Item 51, App C)
Wiping rag (Item 61, App C)
Key washer
Preformed patting
Self-locking nut
Suitable container

Personnel Required:

Unit Mechanic

References:

See your -10
See your LO

Equipment Conditions:

Power plant removed (page 5-11)

REMOVE

1. Remove screw (1), key washer (2), two clamps (3) and hoses (4 and 5) from transmission (6). Discard key washer.
2. Remove screw (7), locknut (8), clamp (9), and two hoses (4 and 5) from bracket (10). Discard locknut.
3. Disconnect hose (5) from elbow (11). Place hose through hull access opening. Drain oil from cooler into a container.
4. Disconnect hose (5) from elbow (11).
5. Loosen jamnut (13) and remove elbow (12) from transmission (6). Use adjustable wrench.
6. Remove valve (14) from elbow (12).
7. Remove preformed packing (15) from elbow (12). Discard packing.

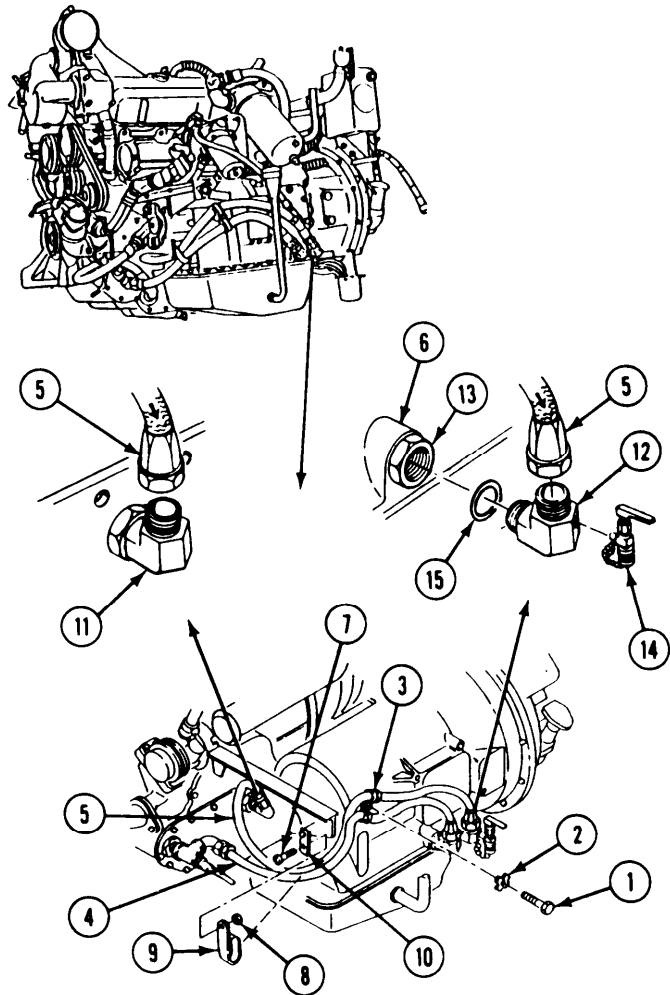

CLEAN, INSPECT, AND REPLACE



WARNING
 Dry cleaning solvent is flammable. Keep it away from heat or open flame. Use in well ventilated area. Do not let it get on your skin.

8. Clean hose and fitting with dry cleaning solvent.
9. Check hose. Replace broken, twisted, or worn hose.
10. Check fitting. Replace fitting that is cracked or has stripped threads.

INSTALL

11. Apply a thin, even coat of sealing compound to cleaned external threads of fittings before installation.
12. Install valve (1) in elbow (2).
13. Install new preformed packing (3) on elbow (2).
14. Install elbow (2) in transmission (4). Tighten jamnut (5) on elbow (2). Use adjustable wrench.
15. Connect hose (6) to two elbows (2 and 7).
16. Install two hoses (6 and 8) on bracket (9). Secure with clamp (10), screw (11), and new locknut (12).

17. Install two hoses (6 and 8) on transmission (4). Secure with two clamps (13), screw (14), and new key washer (15).
18. Check transmission oil level (see your -LO).
19. Install air cleaner element and container (page 7-7).



WARNING
 Carbon monoxide is poisonous and can kill you. Do not idle engine with bottom access cover and power plant access panels off unless there is ADEQUATE VENTILATION.

20. Start engine (see your -10). Check for leaks.

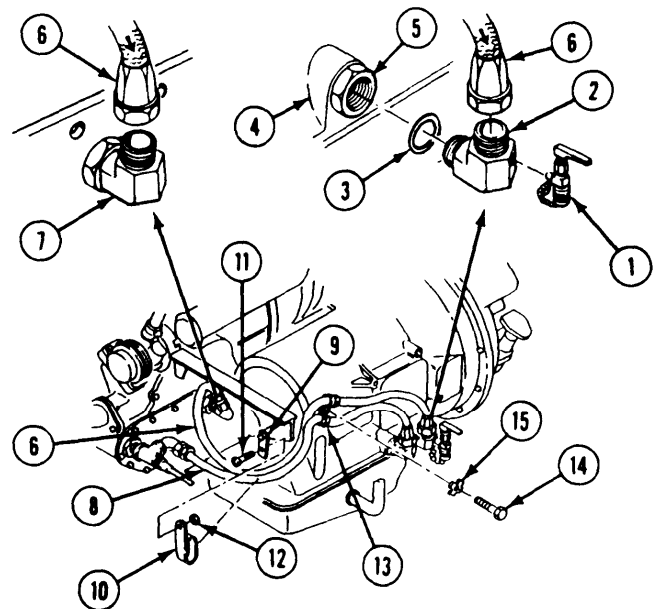

FOLLOW-THROUGH STEPS

1. power plant installed (page 5-11).
-

END OF TASK

REPLACE TRANSMISSION VENT AND FILLER TUBE

DESCRIPTION

This task covers: Remove (page 18-6). Clean, Inspect and Replace (page 18-7).
Install (page 18-7).

INITIAL SETUP

Tools:

General Mechanics Tool Kit (Item 28, App D)

Materials/Parts:

Antiseize compound (Item 4, App C)
Dry cleaning solvent (Item 13, App C)
Sealing compound (Item 51, App C)
Key washer

Personnel Required:

Unit Mechanic

References:

See your -10
See your LO

Equipment Conditions:

Engine stopped/shutdown (see your -10)
Driver's power plant access panel removed
(page 24-27)
Trim vane lowered (see your -10)
Power plant front access door open
(see your -10)
Air cleaner element and container removed
(page 7-7)
Carrier blocked (see your -10)
Hull bottom access cover removed
(page 24-34)

REMOVE

1. Drain transmission (see your LO).
2. Remove dipstick (1) from filler tube
3. Disconnect and remove vent tube (3) from two elbows (4 and 5).
4. Remove elbow (4) from transmission (6).
5. Remove elbow (5) from filler tube (2).
6. Remove screw (7), tab washer (8), and filler tube (2) from engine oil filter bracket (9). Discard tab washer.
7. Loosen filler tube nut (10). Remove filler tube (2) from transmission (6).

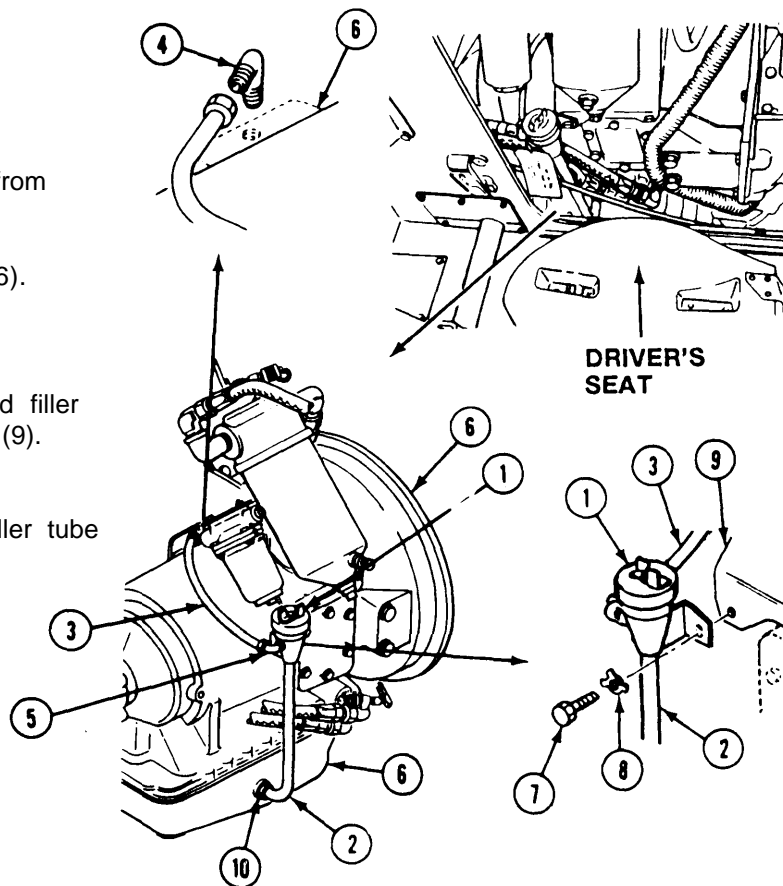

CLEAN, INSPECT, AND REPLACE



WARNING

Dry cleaning solvent P-D-680 is toxic and flammable. Always use in an open area with good air flow, away from sparks, heat, or flames. Wear goggles and gloves. Do not breathe vapors. Avoid contact with skin, eyes, and clothes. If you get dizzy while using solvent, breathe fresh air and get medical help. If solvent gets on hands, wash them. If solvent gets in eyes, flush eyes with fresh water and get medical help immediately. Keep fire extinguisher nearby.

8. Clean parts with dry cleaning solvent.
9. Check vent tube, filler tube, and dipstick. Replace cracked or bent tubes or dipstick.
10. Check fittings. Replace fittings that are cracked or have stripped threads.

INSTALL

11. Apply a light coat of sealing compound to cleaned threads of fittings before installation.
12. Install filler tube (1) in transmission (2). Tighten filler tube nut (3) finger tight.
13. Place filler tube (1) against engine oil filter bracket (4).
14. Apply antiseize compound to threads of screw (5). Secure filler tube (1) to bracket (6) with screw (7) and new tab washer (8).
15. Tighten tube filler nut (3).

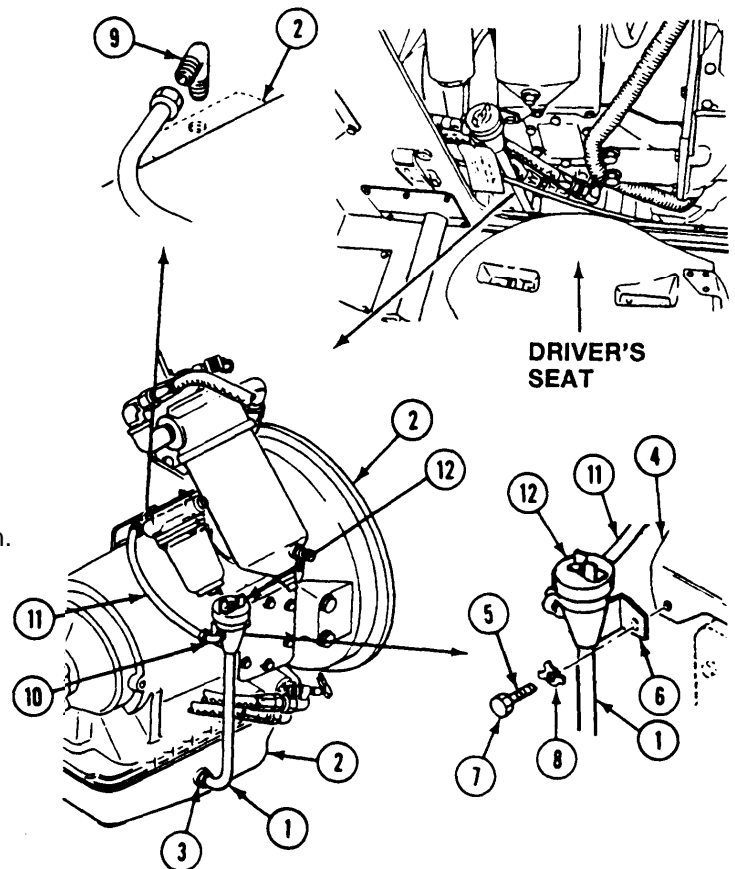

16. Install elbow (9) in transmission (2).
17. Install elbow (10) in filler tube (1).
18. Connect vent tube (11) in filler tube (1).
19. Install dipstick (12) in filler tube (1).
20. Fill transmission with oil (see your LO).
21. Start engine (see your -10). Check for leaks.

FOLLOW-THROUGH STEPS

1. Stop/shutdown engine (see your -10).
2. Install driver's power plant access panel (page 24-25).
3. Install air cleaner element and container (page 7-7)
4. Close power plant front access door (see your -10).
5. Raise trim vane (see your -10).
6. Install hull bottom access cover (page 24-32).

END OF TASK

REPLACE TRANSMISSION OIL FILTER AND DRAIN

DESCRIPTION

This task covers: Remove (page 18-8). Clean, Inspect, and Repair (page 18-8).
Install (page 18-9).

INITIAL SETUP

Tools:

General Mechanics Tool Kit (Item 30, App D)

Materials/Parts:

Dry cleaning solvent (Item 13, App C)
Gasket
Oil filter parts kit
Suitable container

Personnel Required:

Unit Mechanic

References:

see your -10
See your LO

Equipment Conditions:

Engine stopped/shutdown (see your -10)
Carrier blocked (see your -10)
Driver's power plant access panel removed (page 24-25)
Hull bottom access cover removed (page 24-32)
Differential oil pump hose disconnected (page 21-2)

REMOVE

1. Drain transmission (see your LO).
2. Remove drain plug (1) and gasket (2) from transmission (3). Discard gasket.
3. Remove nut (4), screw (5), strap (6), and cover (7) from transmission (3).
4. Remove spring (8), retainer (9), two preformed packings (10 and 11), and element (12) from transmission (3). Discard packings and element.

7. Check plug and screw. Replace plug or screw that has stripped threads.

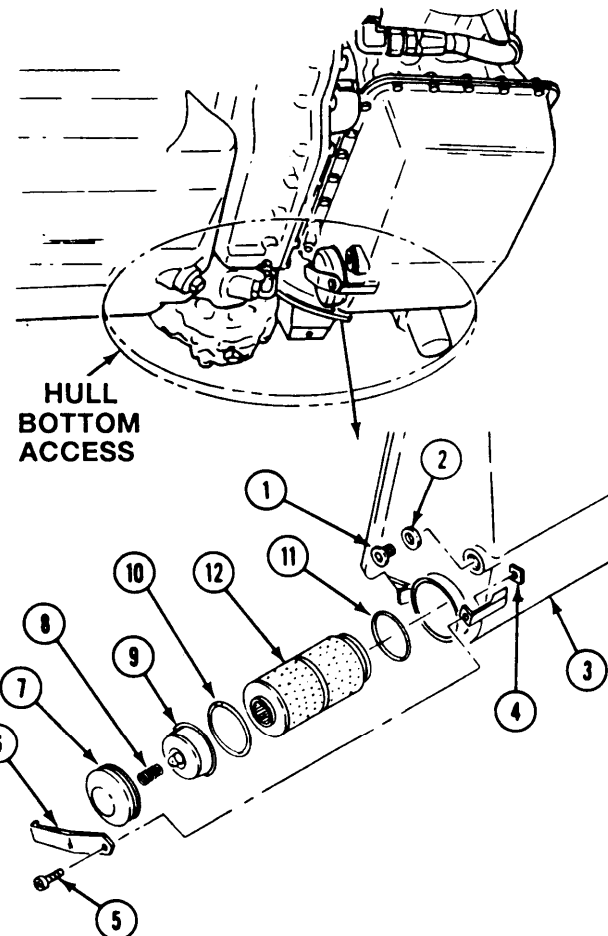

CLEAN, INSPECT, AND REPAIR

WARNING

Dry cleaning solvent is flammable. Keep it away from heat or open flame. Use in well ventilated area. Do not let it get on your skin.

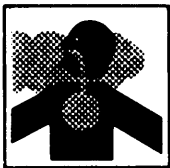

5. Clean transmission oil filter element cavity with dry cleaning solvent.
6. Check cover and strap. Replace or repair cover or strap that is cracked or bent.

INSTALL

8. Install new preformed packing (1), new element (2), and new preformed packing (3) in transmission (4).
9. Install retainer (5), spring (6), cover (7), and strap (8), on transmission (4). Secure with screw (9) and nut (10).
10. Install new gasket (11) and drain plug (12) in transmission (4).
11. Fill transmission with oil (see your LO).

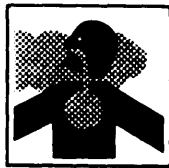

WARNING

Carbon monoxide is poisonous and can kill you. Do not idle engine with bottom access cover and power plant access panels off unless there is VERY GOOD

AIR FLOW.

12. Connect differential oil pump hose (page 21-2).
13. Start engine (see your -10). Check for leaks.

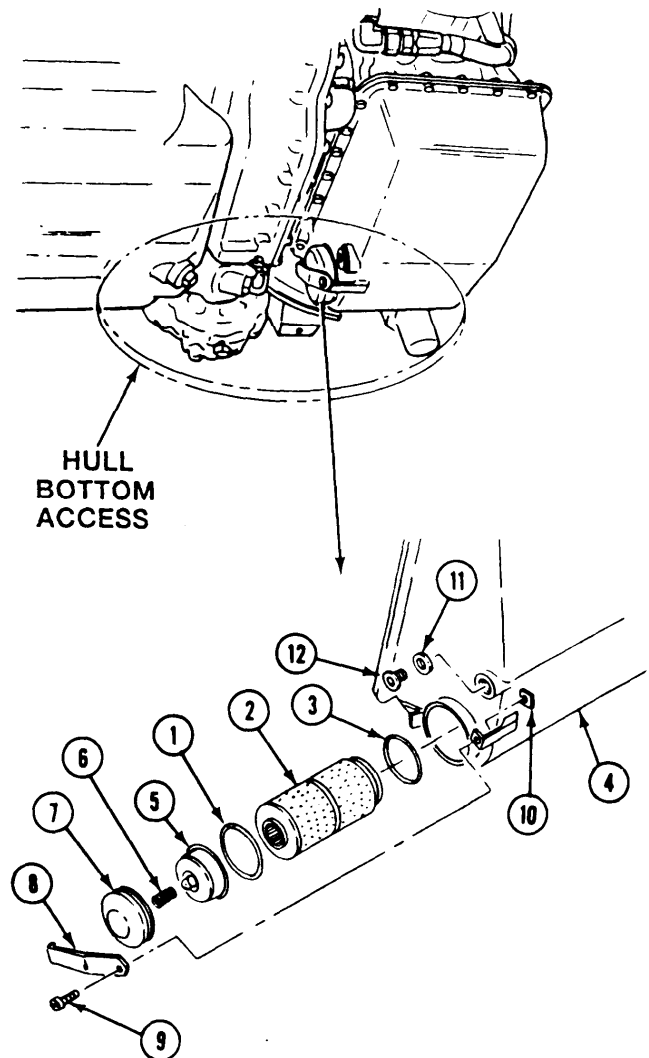

FOLLOW-THROUGH STEPS

1. Stop/shutdown engine (see your -10).
2. Install hull bottom access cover (page 24-32).
3. Install driver's power plant access panel (page 24-25).

END OF TASK

CHAPTER 19
TRANSFER GEARCASE-RELATED COMPONENTS

TASK INDEX

<u>Task</u>	<u>Page</u>	<u>Task</u>	<u>Page</u>
Replace Transfer Gearcase Resilient Mount	19-2	Disassemble/Assemble Transfer Gearcase Oil Filler	19-5
Replace Transfer Gearcase Oil Level Dipstick, Tube, And Guide	19-3	Replace Transfer Gearcase Lifting Eyebolt, Cover, And Plug	19-6
Replace Transfer Gearcase Oil Filler ..	19-4		

REPLACE TRANSFER GEARCASE RESILIENT MOUNT

INITIAL SETUP

Tools:

General Mechanics Tool Kit (Item 30, App D)
Remover and Replacer (Item 55, App D)

Materials/Parts:

Dry cleaning solvent (Item 13, App C)

Personnel Required:

Unit Mechanic

References:

See your -10

Equipment Conditions:

Power plant removed (page 5-11)

REMOVE

1. Remove mount (1) from transfer gearcase (2) using remover and replacer tool (3).

CLEAN, INSPECT, AND REPLACE



WARNING

Dry cleaning solvent P-D-680 is toxic and flammable. Always use in an open area with good air flow, away from sparks, heat, or flames. Wear

goggles and gloves. Do not breathe vapors. Avoid contact with skin, eyes, and clothes. If you get dizzy while using solvent, breathe fresh air and get medical help. If solvent gets on hands, wash them. If solvent gets in eyes, flush eyes with fresh water and get medical help immediately. Keep fire extinguisher nearby.

2. Clean mount with dry cleaning solvent.
3. Check mounts. Replace mount that is cracked, bent, or worn.

INSTALL

4. Use remover and replacer tool to install mount (1) in transfer gearcase (2).

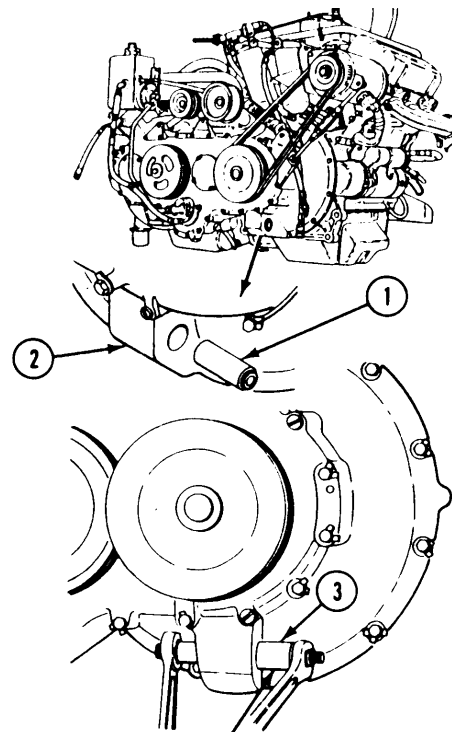

**REMOVER AND REPLACER
(5120-00-740-3346)**

FOLLOW-THROUGH STEPS

1. Install power plant in carrier (page 5-11).
-

END OF TASK

REPLACE TRANSFER GEARCASE OIL LEVEL DIPSTICK, TUBE, AND GUIDE

INITIAL SETUP

Tools:

General Mechanics Tool Kit (Item 30, App D)

References:

see your -10

Materials/Parts:

Dipstick tube
Preformed packing

Equipment Conditions:

Engine stopped/shutdown (see your -10)
Carrier blocked (see your -10)
Power plant rear access panels removed
(page 24-27 or 24-29)

Personnel Required:

Unit Mechanic

REMOVE

1. Remove dipstick (1) from dipstick tube (2).
2. Remove dipstick tube (2) and guide (3) from transfer gearcase (4).
3. Remove preformed packing (5) from dipstick tube (2). Discard packing.

CLEAN, INSPECT, AND REPLACE

4. Check dipstick. Replace dipstick that is bent or worn.
5. Check dipstick tube. Replace tube that is cracked or has stripped threads.
6. Check dipstick guide. Replace guide that is cracked or worn.

INSTALL

7. Position new preformed packing (5) on dipstick tube (2).
8. Install dipstick tube (2) and guide (3) in transfer gearcase (4).
9. Install dipstick (1) in dipstick tube (2).

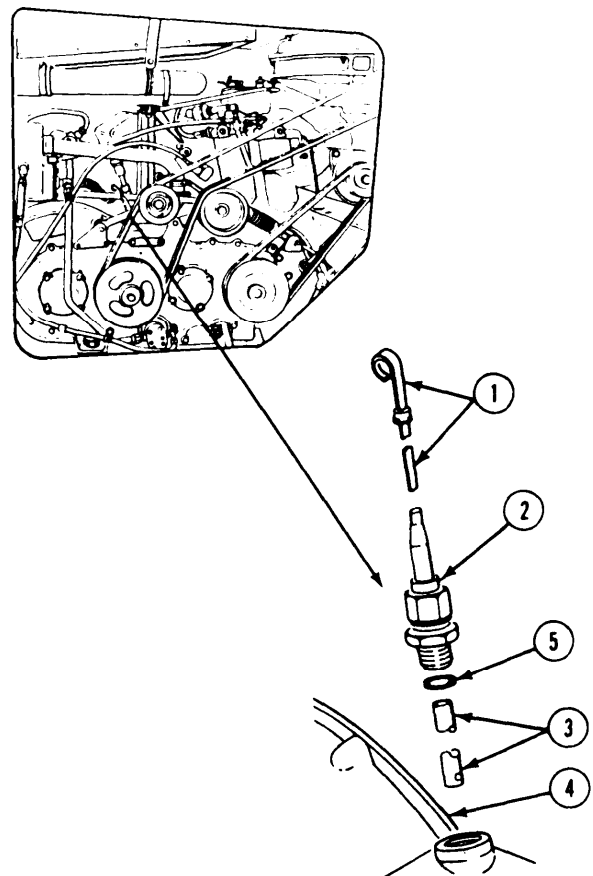

FOLLOW-THROUGH STEPS

1. Install power plant rear access panels
(page 24-27 or 24-29).
-

END OF TASK

REPLACE TRANSFER GEARCASE OIL FILLER

INITIAL SETUP

Tools:

General Mechanics Tool Kit (Item 30, App D)

Materials/Parts:

Dry cleaning solvent (Item 13, App C)
Sealing compound (Item 50, App C)
Oil filler rivet

Personnel Required:

Unit Mechanic

References:

see your -10

Equipment Conditions:

Engine stopped/shutdown (see your -10)
Driver's power plant access panel removed (page 24-25)
Power plant rear access panel removed (page 24-27 or 24-29)
Carrier blocked (see your -10)

REMOVE

1. Remove rivet (1) and oil filler (2) from transfer gearcase (3). Discard rivet.

CLEAN, INSPECT, AND REPAIR



WARNING
Dry cleaning solvent is flammable. Keep it away from heat or open flame. Use in well ventilated area. Do not let it get on your skin.

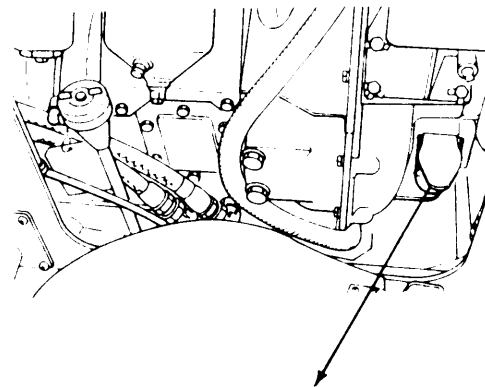

2. Clean oil filler with dry cleaning solvent.
3. Check oil filler. Replace oil filler that has a cracked body. See page 19-5 for disassembly/assembly.

INSTALL

4. Apply a thin, even coat of sealing compound to cleaned base of oil filler (2).
5. Install oil filler (2) in transfer gearcase (3) and secure with new rivet (1).

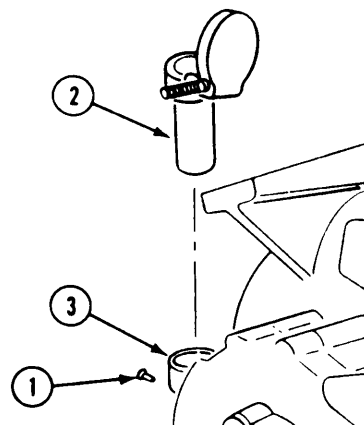

FOLLOW-THROUGH STEPS

1. Install power plant rear access panels (page 24-27 or 24-29).
 2. Install driver's power plant access panel (page 24-25).
-

END OF TASK

DISASSEMBLE/ASSEMBLE TRANSFER GEARCASE OIL FILLER

INITIAL SETUP

Tools:

General Mechanics Tool Kit (Item 30, App D)

Materials/Parts:

Preformed packing

Personnel Required:

Unit Mechanic

References:

see your -10

Equipment Conditions:

Filler assembly removed from carrier
(page 19-4)

REMOVE

1. Remove spring (1) from two posts (2).
2. Remove pin (3) from cap (4).
3. Remove cap (4) from body (5).
4. Remove preformed packing (6) from cap (4).
Discard packing.

CLEAN, INSPECT, AND REPLACE

5. Check fittings and mounting for cracks and wear. Replace as needed.

INSTALL

6. Install new preformed packing (6) in cap (4).
7. Install cap (4) on body (5).
8. Install pin (3) on cap (4).
9. Install spring (1) on two posts (2).

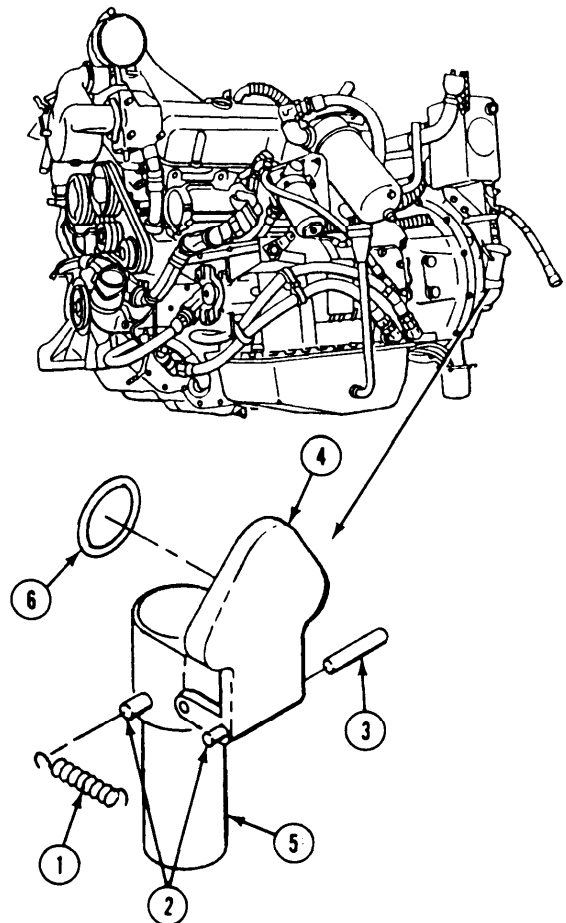

FOLLOW-THROUGH STEPS

1. Install filler assembly in transfer gearcase
(page 19-4).
-

END OF TASK

REPLACE TRANSFER GEARCASE LIFTING EYEBOLT, COVER, AND PLUG

INITIAL SETUP

Tools:

General Mechanics Tool Kit (Item 30, App D)

Materials/Parts:

Preformed packing

Personnel Required:

Unit Mechanic

References:

See your -10
See your LO

Equipment Conditions:

Engine stopped/shutdown (see your -10)
Ramp lowered (see your -10)
Power plant rear access panels removed
(page 24-27 or 24-29)
Carrier blocked (see your -10)
Power plant bottom access cover removed
(page 24-32)
Suitable container placed under hull opening
to catch oil
Transfer gearcase drained into container
(see your LO)

REMOVE

1. Remove eyebolt (1) from transfer gearcase (2).
2. Remove two screws (3) and cover (4) from gearcase (2).
3. Remove plug (5) and preformed packing (6) from bottom of gearcase (2). Discard packing.

INSPECT, CLEAN, AND REPLACE

4. Check fittings and housing for cracks and damage. Replace as needed.

INSTALL

5. Install new preformed packing (6) and plug (5) in gearcase (2).
6. Install cover (4) and two screws (3) in gearcase (2).
7. Install eyebolt (1) on gearcase (2).

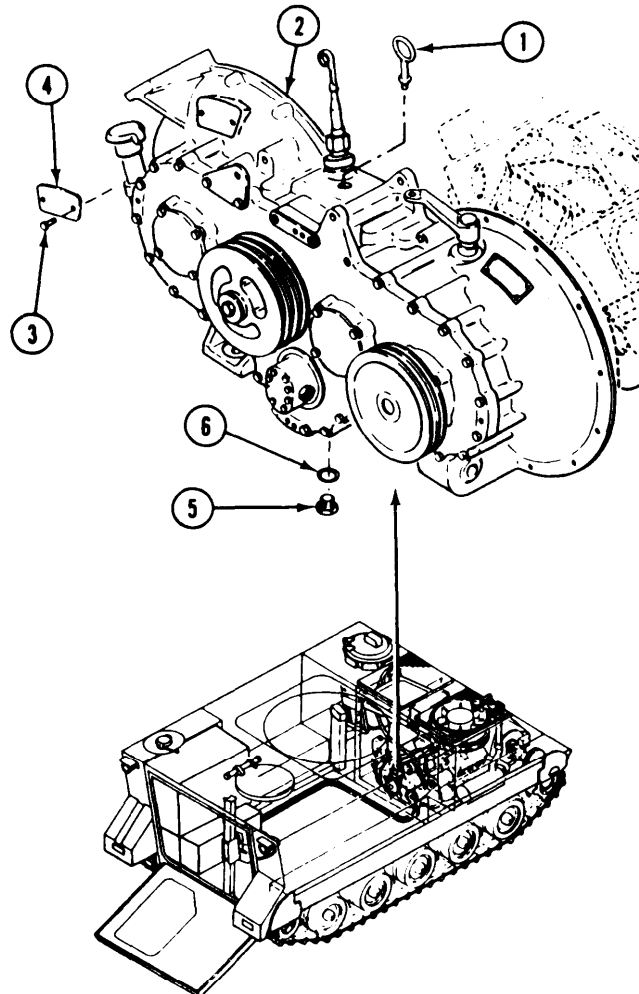

FOLLOW-THROUGH STEPS

1. Make sure transfer gearcase drain plug is secure. Remove container from under hull opening.
2. Install power plant bottom access cover (page 24-32).
3. Fill transfer gearcase with oil (see your LO).
4. Start engine (see your -10). Check for leaks.
5. Stop/shutdown engine (see your -10).
6. Install power plant rear access panels (page 24-27 or 24-29).
7. Raise and lock ramp (see your -10).

**WARNING**

Loose clothing is dangerous around moving belts and pulleys. You could get badly hurt if your clothes get caught in moving parts.

END OF TASK

**CHAPTER 20
DRIVE SHAFTS, UNIVERSAL JOINTS, AND FINAL DRIVE
MAINTENANCE**

TASK INDEX

<u>Task</u>	<u>Page</u>	<u>Task</u>	<u>Page</u>
Replace Transmission To Differential Shaft	20-2	Replace Final Drive	20-9
Replace Left Final Drive Shaft	20-5	Replace Final Drive Pinion Oil Seal .	20-11
Replace Right Final Drive Shaft	20-7	Replace Final Drive Filler Tube And Dipstick	20-12

REPLACE TRANSMISSION TO DIFFERENTIAL SHAFT

DESCRIPTION

This task covers: Remove (page 20-2). Clean, Inspect, and Repair (page 20-3).
Install (page 20-4).

INITIAL SETUP

Tools:

- General Mechanics Tool Kit (Item 30, App D)
- Torque Wrench Adapter, 7C U-Joint (Item 7, App D)
- Torque Wrench Adapter, 6C U-Joint (Item 8, App D)
- Torque Wrench (Item 96, App D)

Materials/Parts:

- Dry cleaning solvent (Item 13, App C)
- Screw (16)

Personnel Required:

Unit Mechanic

References:

See your -10

Equipment Conditions:

- Engine stopped/shutdown (see your -10)
- Carrier blocked (see your -10)
- Trim vane lowered (see your -10)
- Power plant front access door open (see your -10)

REMOVE

NOTE

Place gear range selector in neutral position. Set or release differential steering brakes as required to rotate or lock shaft during removal or installation (see your -10).

1. Remove eight screws (1), flat washers (2), and shaft (3) from two universal joints (4). Discard screws.
2. Remove eight screws (5), flat washers (6), and two universal joints (4) from differential yoke (7) and transmission yoke (8). Discard screws.
3. Remove yoke (7) from differential (9).
4. Deleted.

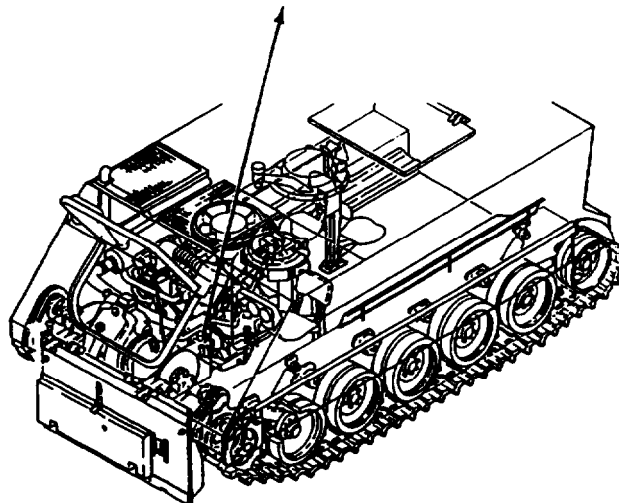
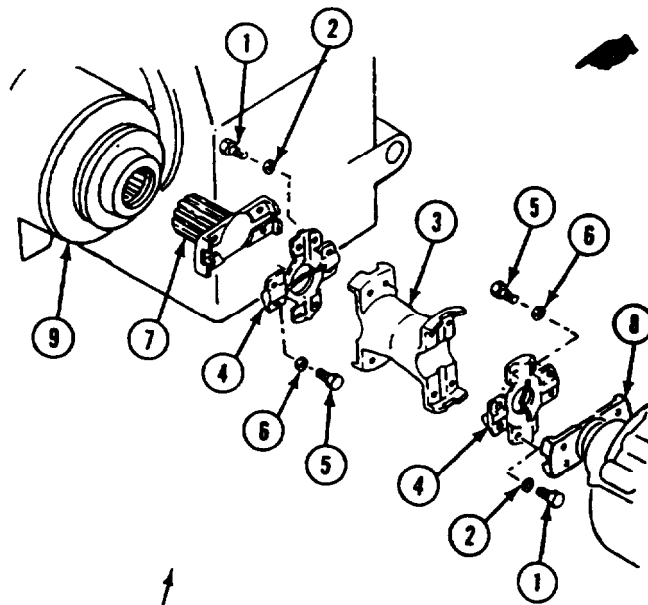

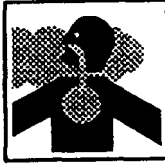
CLEAN, INSPECT, AND REPAIR**WARNING**

Dry cleaning solvent P-D-680 is toxic and flammable. Always use in an open area with good air flow, away from sparks, heat, or flames. Wear goggles and gloves. Do not breathe vapors. Avoid contact with skin, eyes, and clothes. If you get dizzy while using solvent, breathe fresh air and get medical help. If solvent gets on hands, wash them. If solvent gets in eyes, flush eyes with fresh water and get medical help immediately. Keep fire extinguisher nearby.

5. Clean shaft, universal joints, yoke, screw mounting holes and attaching hardware with dry cleaning solvent.

CAUTION

Early failure due to wear will occur if you wash lubricant out of universal joint bearings.

6. Inspect shaft and universal joints for wear, deep scratches, grooves, and cracks. Remove minor scratches and grooves. Replace part if damage cannot be repaired.
7. Inspect yoke for chipped, worn, and burred splines. Remove minor scratches and burs. Replace yoke if damage cannot be repaired.
8. Clean mounting surfaces of shaft to ensure correct torque.

GO TO NEXT PAGE

INSTALL

9. Deleted.

CAUTION

Transmission or differential damage could result if universal joint and shaft are not aligned properly.

10. Install yoke (1) in differential (2).

NOTE

New style universal joints are permanently lubricated.

11. Install eight new screws (3) with washers (4) to secure universal joints (5) on transmission yoke (6) and differential yoke (1).

NOTE

Screws and washers must be clean, dry, and free of lubricants and paint.

12. Install eight new screws (7) with washers (8) to secure shaft (9) to two universal joints (5).

13. Use torque wrench and adapter to tighten screws to 86 to 94 lb-ft (117-128 N·m) torque. Loosen and retighten to correct torque. See page 2-30 for torque wrench reading with adapter.

14. Deleted.

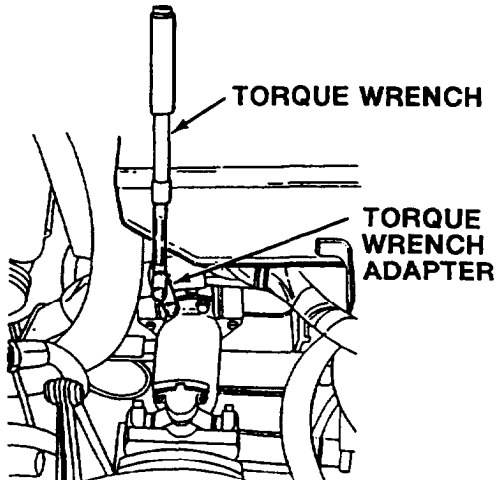
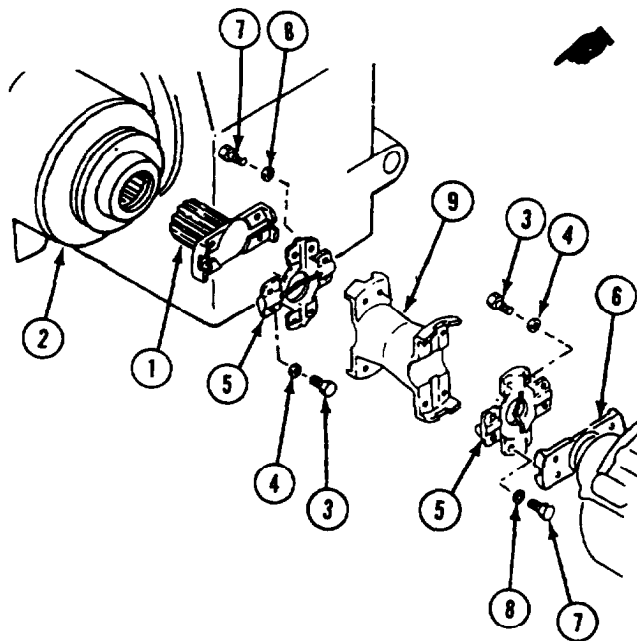

FOLLOW-THROUGH STEPS

1. Close power plant front access door (see your -10).

2. Raise trim vane (see your -10).

3. Road test carrier (page 2-45) to check transmission-to-differential shaft.

4. Engine stopped/shutdown (see your -10).

END OF TASK

REPLACE LEFT FINAL DRIVE SHAFT

DESCRIPTION

This task covers: Remove (page 20-5). Install (page 20-6).

INITIAL SETUP

Tools

General Mechanics Tool Kit (Item 30, App D)
 Vim (Item 76, App D)
 Torque Wrench (Item 96, App D)
 Torque Wrench Adapter (Item 9, App D)

Materials/Parts:

Screw (16)
 Self-locking nut (4)
 Washer (16)

Personnel Required:

Unit Mechanic
 Helper (H)

References:

See your -10
 See your LO

Equipment Conditions:

Engine stopped/shutdown (see your -10)
 Carrier blocked (see your -10)
 Trim vane lowered by your -10)
 Power plant front access door open
 (see your -10)
 Hull front access cover removed (page 24-24)

REMOVE

NOTE

Loosen accessible screws only enough to relieve torque. Move carrier to gain access to remaining screws.

1. Remove eight screws (1) and washers (2) from universal joints (3) and slide yoke (4) into final drive (5). Discard screws and washers.
2. Remove propeller shaft (6) with universal joints from carrier.
3. Position propeller shaft (6) in vise. Remove eight screws (7) and washers (8) from universal joints (3) and shaft. Discard screws and washers.
4. Remove yoke (4) from final drive (5).
5. Remove four locknuts (9) and adapter (10) from differential (11). Discard locknuts.
6. Remove four lube fittings (12) from two universal joints (3), if required.

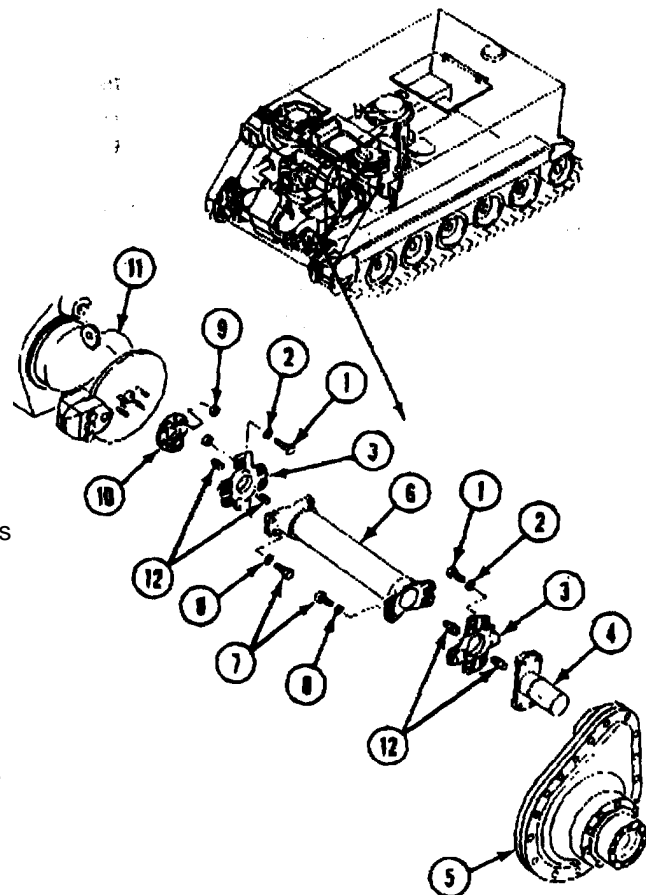

GO TO NEXT PAGE

INSTALL

- 7. Deleted.
- 8. Secure adapter (1) to differential (2) with four new locknuts (3). Tighten nuts to 75-80 lb-ft (102-108 N•m) torque. Use torque wrench.
- 9. Install yoke (4) in final drive (5).

NOTE

When using torque wrench with torque wrench adapter, torque value must be corrected. Procedure for converting torque value is on page 2-32.

- 10. Position propeller shaft (6) in vise and install universal joints (7) with eight new screws (8) and washers (9). Tighten screws to 35-40 lb-ft (47-54 N•m) torque. Use torque wrench and torque wrench adapter. Loosen screws, then tighten again to 35-40 lb-ft (47-54 N•m) torque.

- 11. Position propeller shaft (6) with universal joints (7) and secure to differential (2) and final drive (6) with eight new screws (8) and washers (9). Tighten screws to 35-40 lb-ft (47-54 N•m) torque. Use torque wrench and adapter. Loosen screws, then tighten again to 35-40 lb-ft (47-54 N•m) torque.
- 12. Deleted.

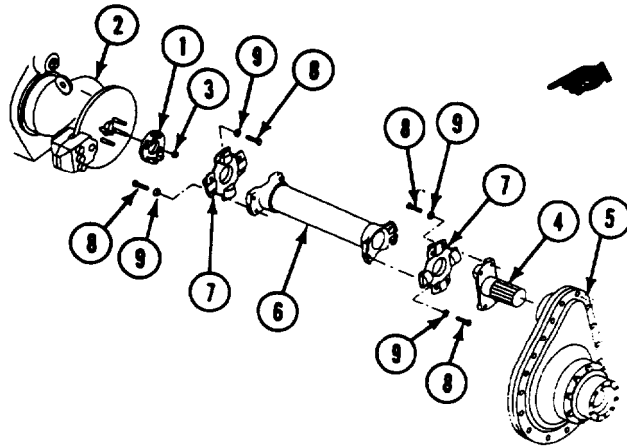

FOLLOW-THROUGH STEPS

- 1. Install hull front access cover (page 24-24).
- 2. Close power plant front access door (see your -10).
- 3. Raise trim vane (see your -10).

END OF TASK

REPLACE RIGHT FINAL DRIVE SHAFT

INITIAL SETUP

Tools:

- General Mechanics Tool Kit (Item 30, App D)
- Torque Wrench Adapter (Item 9, App D)
- Vise (Item 76, App D)
- Torque Wrench (Item 96, App D)

Materials/Parts:

- Screw (16)
- Self-locking nut (4)

Personnel Required:

Unit Mechanic

References:

See your -10

Equipment Conditions:

- Engine stopped/shutdown (see your -10)
- Carrier blocked (see your -10)
- Trim vane lowered and power plant front access door open (see your -10)

REMOVE

NOTE

Place gear range selector in neutral position. Set or release differential steering brakes as required to rotate or lock drive shaft during removal and installation.

1. Remove eight screws (1) and washers (2) from universal joints (3). Pry universal joints loose and slide yoke (4) into final drive (5). Discard screws.
2. Remove propeller shaft (6) with universal joints (3) from carrier.
3. Position propeller shaft (6) in vise. Remove eight screws (7) and washers (8) from universal joints and shaft. Discard screws.

4. Remove yoke (4) from final drive (5).

5. Remove four locknuts (9) and adapter (10) from differential (11). Discard locknuts.

6. Deleted.

INSTALL

7. Deleted.

8. Install yoke (4) in final drive (5).

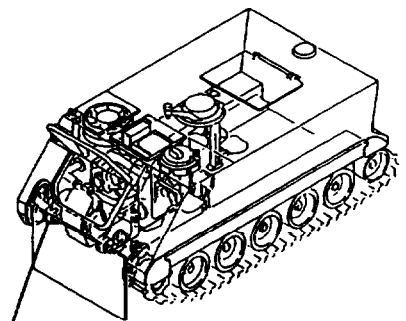
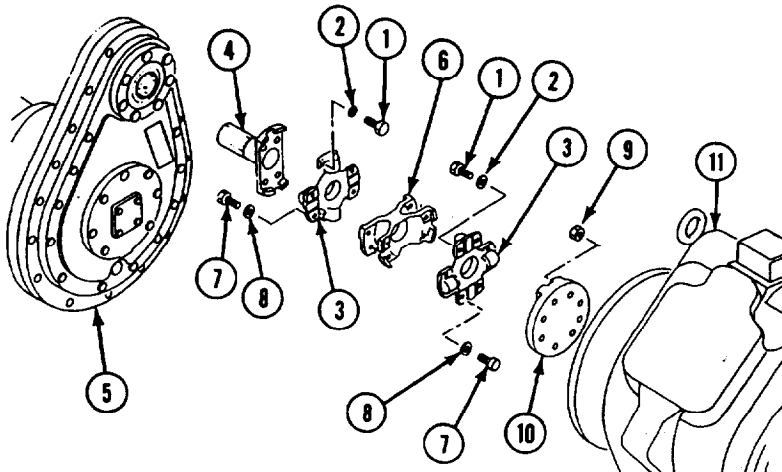

GO TO NEXT PAGE

9. Secure adapter (1) to differential (2) with four new locknuts (3). Tighten nuts to 75-80 lb-ft (102-108 NŹm) torque. Use torque wrench.

CAUTION

Final drive or differential damage could result if universal joints and shaft are not aligned right. Align and tighten all screws to correct torque.

NOTE

Screws and washers must be clean, dry and free of lubricants and paint. Washers must be 5/32-inch (4 mm) hardened flat steel only.

10. Position propeller shaft (4) in vise and install universal joints (5) with eight new screws (6) and washers (7). Tighten screws to 35-40 lb-ft torque. Use torque wrench and adapter. Loosen screws and tighten again to 35-40 lb-ft torque.

11. Position propeller shaft (4) with universal joints (5) and secure to differential adapter (1) and final drive yoke (8) with eight new screws (9) and washers (10). Tighten screws to 35-40 lb-ft torque. Use torque wrench and adapter. Loosen screws and tighten again to 35-40 lb-ft.

12. Deleted.

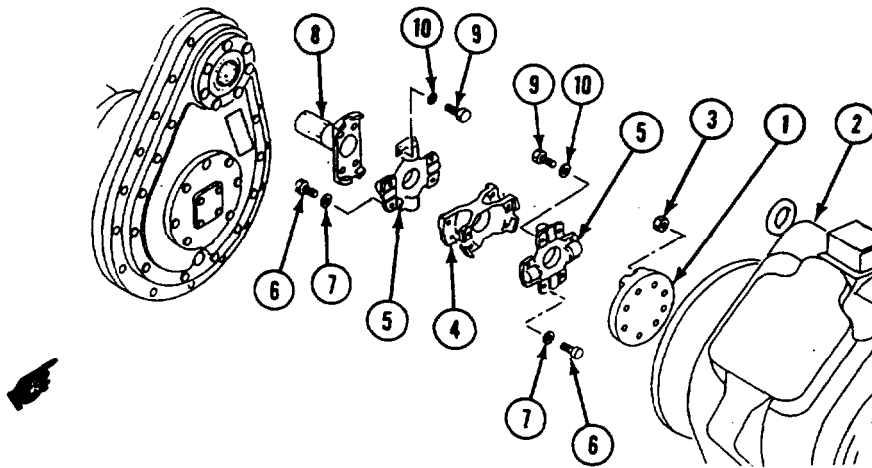

FOLLOW-THROUGH STEPS

1. Close power plant front access door and raise trim vane (see your -10).
2. Road test carrier (page 2-45) to check right final drive shaft.
3. Stop/shutdown engine (see your -10).

END OF TASK

REPLACE FINAL DRIVE

DESCRIPTION

This task covers: Remove (page 20-9). Clean, Inspect, and Repair (page 20-10).
Install (page 20-10).

INITIAL SETUP

Tools:

General Mechanics Tool Kit (Item 30, App D)
Lifting Bar (Item 12, App D)
Torque Wrench (Item 96, App D)

Materials/Parts:

Antiseize compound (Item 4, App C)

Personnel Required:

Unit Mechanic
Helper

References:

See your -10
See your LO

Equipment Conditions:

Engine stopped/shutdown (see your -10)
Carrier blocked (see your -10)
Power plant front access door opened
(see your -10)
Final drive yoke removed (page 20-5)
Track shroud removed (page 22-2)
Track removed from drive sprocket
(page 22-4)
Trim vane lowered (see your -10)
Track drive sprocket removed from final drive
(page 22-30)

REMOVE

1. If left final drive is to be removed, remove hull front access cover (page 24-24). Remove left final drive speedometer cable and adapter (page 11-17).
2. Drain final drive (see your LO).



WARNING

The final drive is heavy and can cause back injury if handled improperly. Be sure to use a hoist or a helper to remove final drive.

3. Secure lifting bar (1) to final drive (2) with two sprocket mounting screws (3).
4. Attach suitable lifting device of at least 165 lb (75 kg) capacity to lifting bar (1).

5. Remove 17 screws (4), washers (5), and final drive (2) from hull (6).

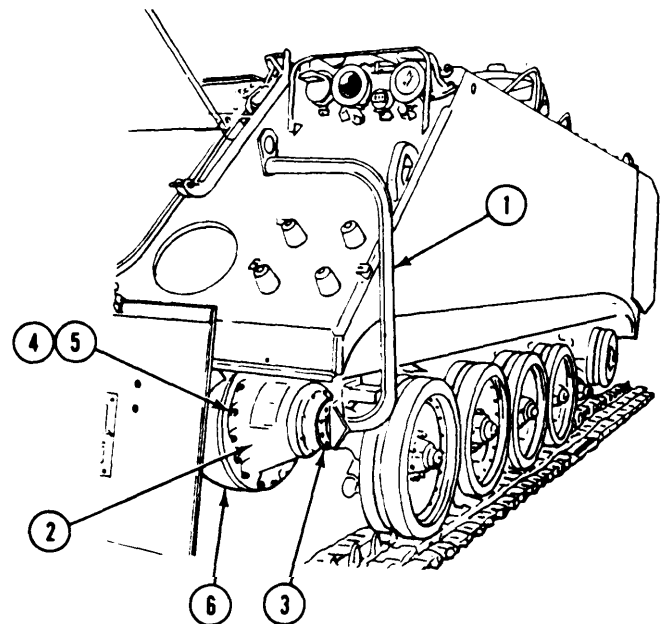

GO TO NEXT PAGE

CLEAN, INSPECT, AND REPAIR

6. Replace final drive that shows cracks or leaks other than differential oil seal leak. Leaking pinion oil seal can be replaced (page 20-11).
7. Check mounting surfaces and internal spline for breaks, nicks, deep scratches and burs. Repair minor damage. Replace final drive if damage cannot be repaired.

INSTALL

8. Check final drive drain plug for tightness.
9. If left final drive is to be replaced, remove speedometer shaft adapter from old final drive and install it in new final drive (page 20-2).
10. Fill final drive with oil (see your LO).



WARNING

The final drive is heavy and can cause back injury if handled improperly. Be sure to use a hoist or a helper to remove final drive.

11. Secure lifting bar (1) to final drive (2) with two sprocket mounting screws (3).
12. Attach lifting device of at least 165 lb (75 kg) capacity to lifting bar (1) and position final drive (2) on hull (4).
13. Apply antiseize compound to threads of 17 screws (5).
14. Secure final drive (2) to hull (4) with 17 screws (5) and washers (6). Tighten screws to 75-85 lb-ft (102-115 N•m) torque. Use torque wrench.
15. Remove two screws (3) and lifting bar (1) from final drive (2).

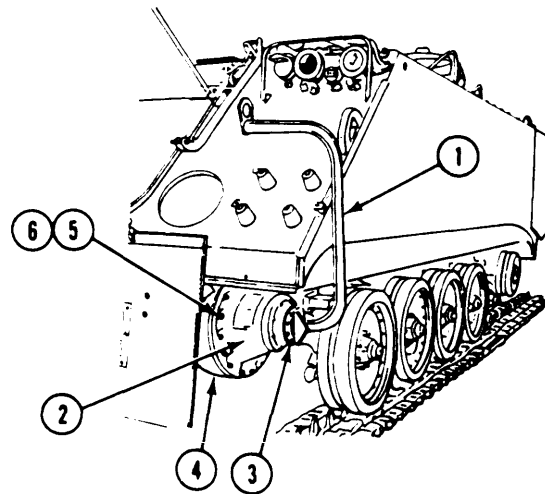

FOLLOW-THROUGH STEPS

1. Install final drive yoke (page 20-5).
2. Install drive sprocket on final drive (page 22-30).
3. Install track on drive sprocket (page 22-4).
4. Install track shroud (page 22-2).
5. Install speedometer cable on adapter (page 11-17) (left final drive only).
6. Install hull tint access cover (page 24-24) (left final drive only).
7. Close power plant tint access door (see your -10).
8. Raise trim vane (see your -10).
9. Road test carrier (page 2-45) to check final drive.
10. Stop/shutdown engine (see your -10).

END OF TASK

REPLACE FINAL DRIVE PINION OIL SEAL

INITIAL SETUP

Tools:

General Mechanics Tool Kit (Item 30, App D)
 Socket Wrench Set (Item 89, App D)
 Torque Wrench (Item 95, App D)

Material/Parts:

Antiseize compound (Item 4, App C)
 Sealing compound (Item 48, App C)
 Gasket
 seal
 Self-locking bolt (4)
 Self-locking bolt (3)

Personnel Required:

Unit Mechanic

References:

See your -10

Equipment Conditions:

Engine stopped/shutdown (see your -10)
 Carrier blocked (see your -10)
 Trim vane lowered (see your -10)
 Power plant front access door opened
 (see your -10)
 Drive shaft removed (page 20-7)
 Final drive yoke removed (page 20-5)
 Hull front access cover removed (left final
 drive only) (page 24-24)

REMOVE

1. Remove seven lockbolts (1), washers (2), cover (3), and gasket (4) from final drive (5). Discard gasket and bolts.
2. Remove seal (6) from cover (3). Discard seal.

CLEAN, INSPECT AND REPLACE

3. Check fittings and housing for cracks, leaks, damage or wear. Replace as needed.

INSTALL

4. Apply sealing compound to new seal (6). Install in cover (3) flush with surface of cover.
5. Apply a light coat of antiseize compound to threads of seven new lockbolts (1).

6. Install new gasket (4) and cover (3) on final drive (5). Secure with seven new lockbolts (1) and washers (2). Tighten screws to 252-300 lb-in (28-34 N•m) torque. Use torque wrench.

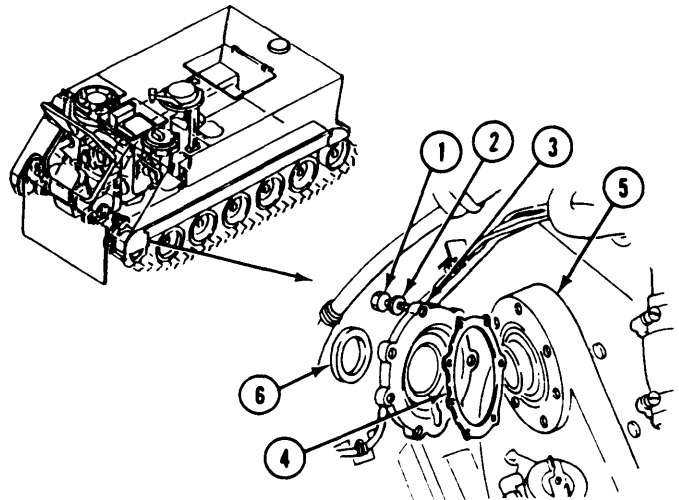

FOLLOW-THROUGH STEPS

1. Install final drive yoke (page 20-5).
2. Install drive shaft (page 20-7).
3. Install hull front access cover (left final drive only) (page 24-24).
4. Close power plant front access door (see your -10).
5. Raise trim vane (see your -10).
6. Remove blocks used to keep carrier from moving (see your -10).
7. Road test earner (page 2-45) to check final drive. Check for leaks around seal.
8. Stop/shutdown engine (see your -10).

END OF TASK

REPLACE FINAL DRIVE FILLER TUBE AND DIPSTICK

DESCRIPTION

This task covers: Remove (page 20-12). Clean, Inspect, and Replace (page 20-12).
Install (page 20-13).

INITIAL SETUP

Tools:

General Mechanics Tool Kit (Item 30, App D)

Materials/Parts:

Antiseize compound (Item 4, App C)
Sealing compound (Item 46, App C)
Key washer
Preformed packing

Personnel Required:

Unit Mechanic

References:

See your -10

Equipment Conditions:

Trim vane lowered (see your -10)
Power plant front access door open
(see your -10)
Final drive removed (page 20-9)

REMOVE

1. Turn dipstick (1) to the left and remove from oil filler tube (2).
2. Remove screw (3), key washer (4), and clamp (5) from final drive (6). Discard key washer.

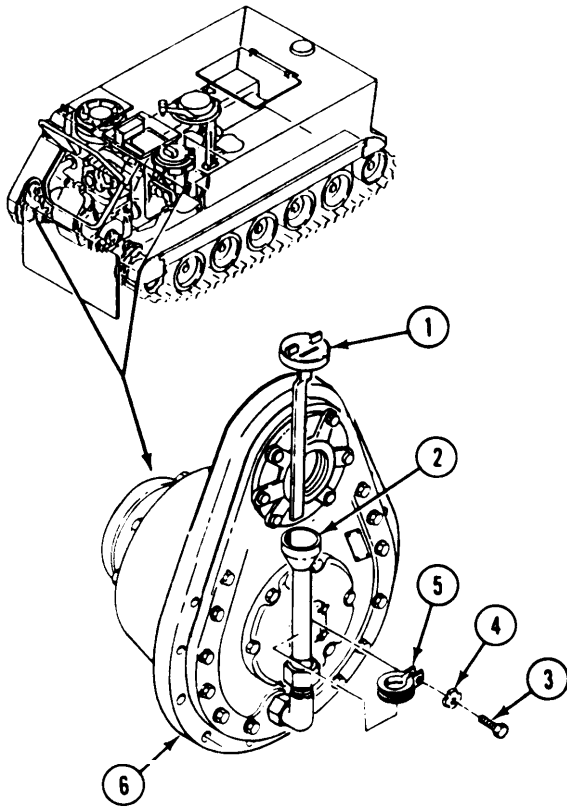

3. Remove nut (7) from elbow (8).
4. Remove vent tube (9) from elbow (10).
5. Remove filler tube (2) and vent tube (9) from final drive (6).
6. Remove elbow (10) from final drive (6).
7. Loosen nut (11). Remove elbow (8) and preformed packing (12) from final drive (6). Discard packing.

CLEAN, INSPECT, AND REPLACE

8. Check parts and housing for cracks, damage, and wear. Replace as needed.

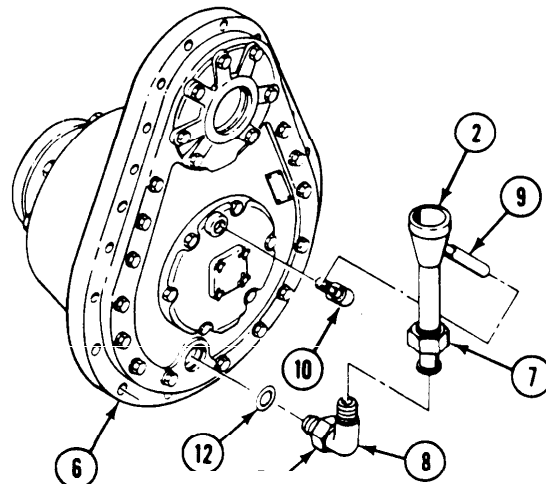

INSTALL

9. Install new preformed packing (1) and elbow (2) in final drive (3). Secure with nut (4).
10. Apply a light coat of sealing compound to threads of elbow (5).
11. Install elbow (5) in final drive (3).
12. Install vent tube (6) on elbow (5).
13. Connect filler tube (7) to vent tube (6) and elbow (2). Do not tighten nut (8).

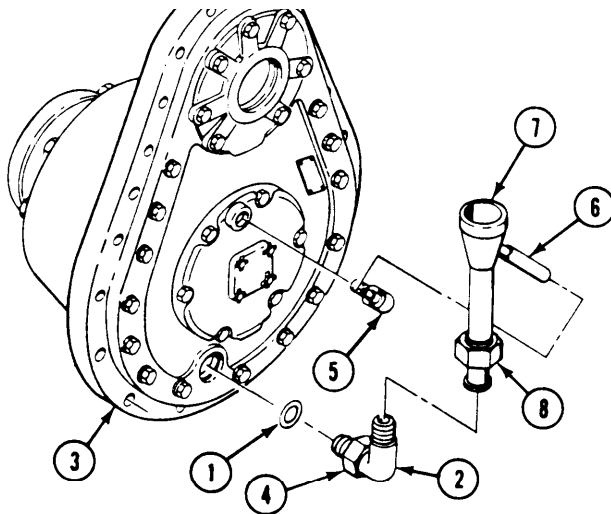
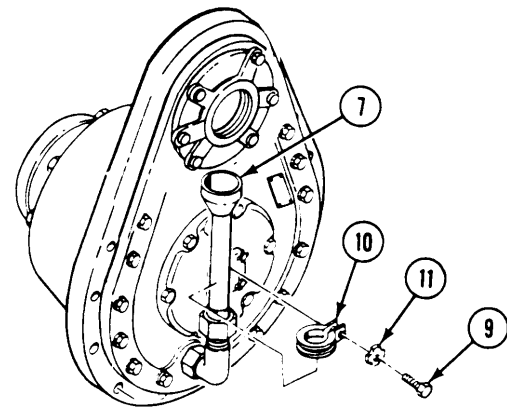

14. Apply a light coat of antiseize compound to threads of screw (9).
15. Secure filler tube (7) to final drive (3) with clamp (10), new key washer (11), and screw (9).
16. Tighten nut (8) to secure filler tube (7) to elbow (2).
17. Install dipstick (12) in filler tube (7) and turn to the right to lock.

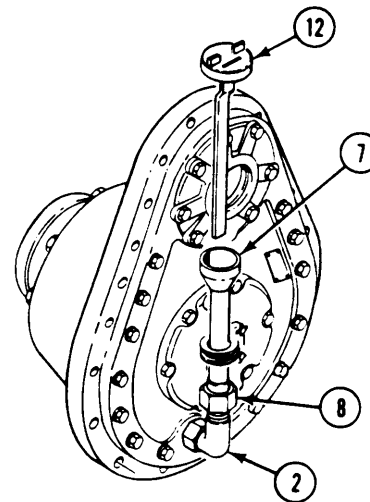

FOLLOW-THROUGH STEPS

1. Install final drive (page 20-9).
2. Close power plant front access door (see your -10).
3. Raise trim vane (see your -10).

END OF TASK

CHAPTER 21 DIFFERENTIAL RELATED COMPONENTS MAINTENANCE

TASK INDEX

<u>Task</u>	<u>Page</u>	<u>Task</u>	<u>Page</u>
Differential Oil Flow Diagram	21-1	Replace Differential Gearbox To Differential Hose And Fittings..	21-12
Replace Differential Oil Pump	21-2	Replace Differential To Oil Cooler Hose And Fittings	21-14
Replace Differential Oil Filter And Fittings	21-6	Replace Differential Oil Filter To Pump Hose And Fittings	21-16
Replace Differential Oil Filter Element	21-8	Differential Brake Adjustment	21-18
Replace Differential Oil Level Dipstick And Breather	21-9	Replace Differential And Mounts	21-20
Replace Differential Oil Pump To Differential Hose And Fittings.	21-10	Replace Differential Gasket	21-23

DIFFERENTIAL OIL FLOW DIAGRAM

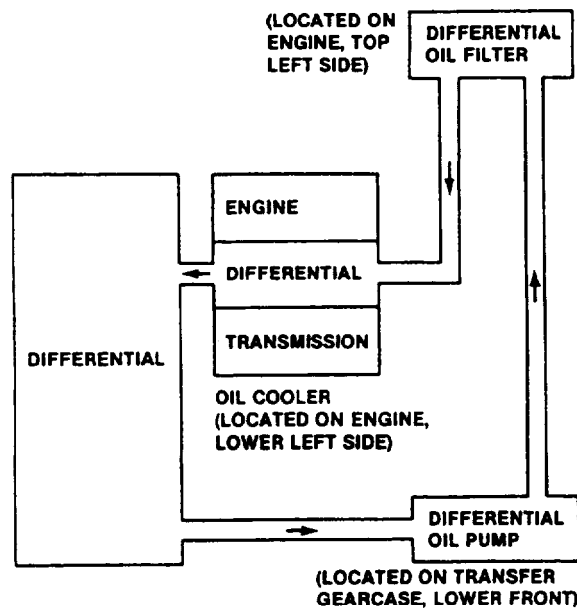

Differential oil is picked up from bottom of the differential by the differential oil pump. The pump forces the oil through the differential oil filter to the differential oil cooler and back to the differential.

GO TO NEXT PAGE

REPLACE DIFFERENTIAL OIL PUMP

DESCRIPTION

This task covers: Remove (page 21-2). Clean, Inspect and Replace (page 21-4)
Install (page 21-4).

INITIAL SETUP

Tools:

General Mechanics Tool Kit (Item 30, App D)
Torque Wrench (Item 96, App D)

References

see your -10
See your LO

Materials/Parts:

Antiseize compound (Item 4, App C)
Oil (Item 14, App C)
Cotter pin
Gasket
Key washers (2)
Packings (3)
Suitable container

Equipment Conditions

Engine stopped/shutdown (see your -10)
Ramp lowered (see your -10)
Carrier blocked (see your -10)
Power plant bottom access cover removed (page 24-32)
Ramp hydraulic pump removed (page 28-81)
Power plant rear access panel removed (page 24-27)

Personnel Required:

Unit Mechanic
Helper (H)

REMOVE

1. Position container under transfer gearcase and drain oil (see your LO).
2. Disconnect oil outlet hose (1) from elbow (2).
3. Disconnect oil inlet hose (3) from quick disconnect coupling half (4).

BOTTOM ACCESS OPENING

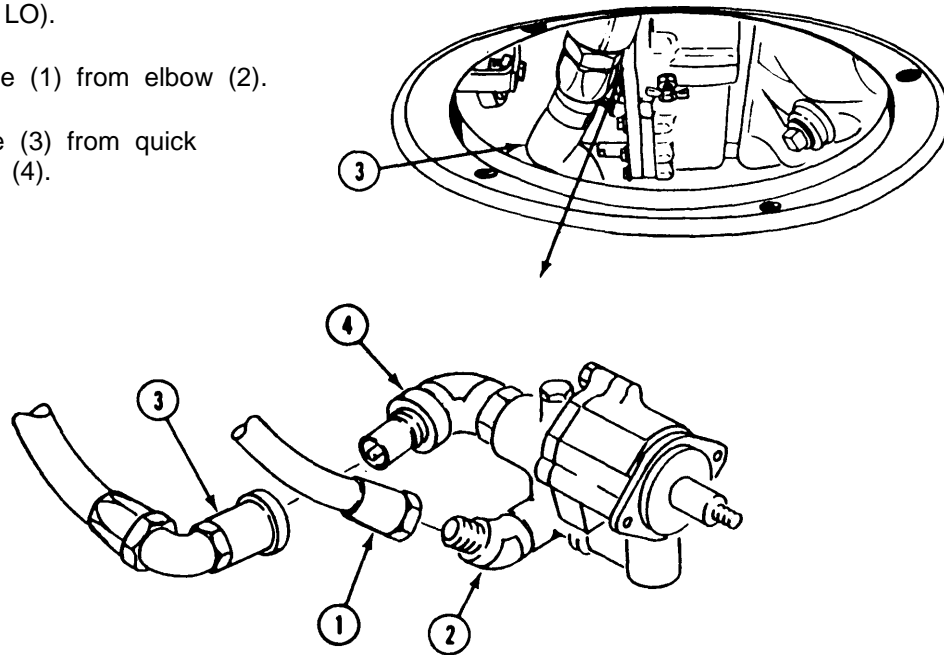

NOTE

Two washers (1) are the maximum used. If two washers are removed, two will be installed.

4. Remove cotter pin (2), nut (3), and washer(s) (1), from differential oil pump (4). Discard cotter pin.
5. Remove two screws (5), key washers (6), and oil pump (4) from transfer gearcase (7). Discard key washers.
6. Remove gasket (8) from oil pump (4). Discard gasket.
7. Remove key (9) and retainer (10) from oil pump (4).
8. Remove elbow (11) and packing (12) from oil pump (4). Discard packing.
9. Remove quick disconnect coupling half (13) and packing (14) from elbow (15). Discard packing.
10. Remove elbow (15), nut (16), retainer (17), and packing (18) from oil pump (4). Discard packing.

REAR COMPARTMENT ACCESS OPENING

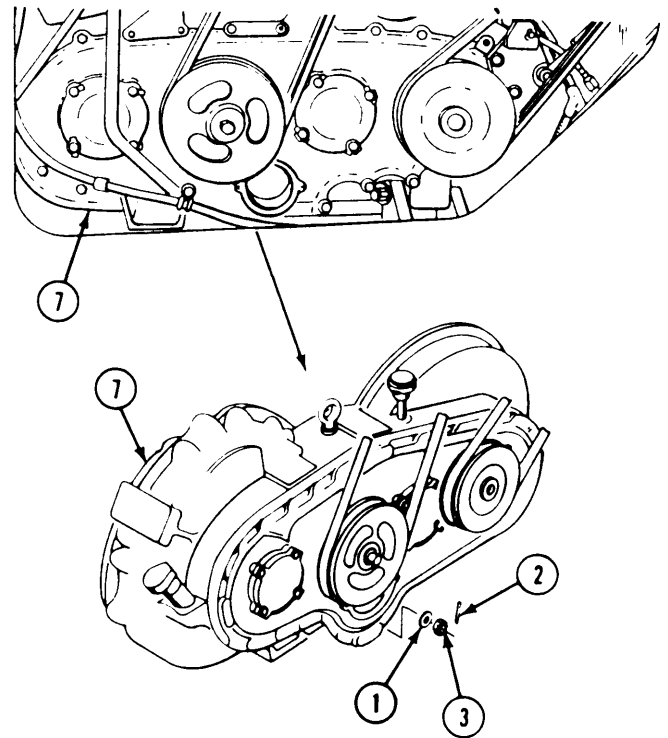

BOTTOM ACCESS OPENING

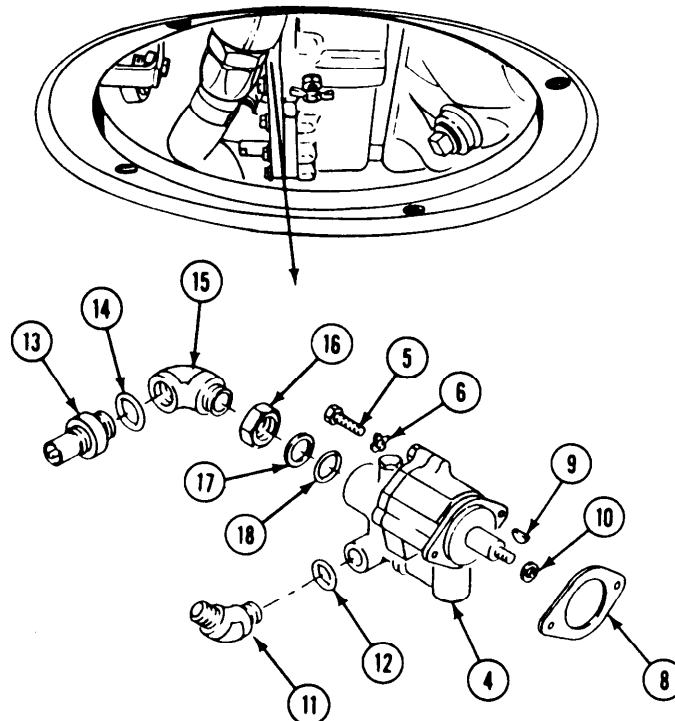

GO TO NEXT PAGE

CLEAN, INSPECT AND REPLACE

11. Check fittings, hardware, hoses and housing for leaks, cracks, damage and wear. Replace if needed.

INSTALL

NOTE

If a new oil pump is being installed, use fittings from old pump.

12. Install new packing (1) and elbow (2) in lump (3).
13. Install new packing (4), retainer (5), nut (6), and elbow (7) in pump (3). Tighten nut (6).
14. Install new packing (8) and quick disconnect coupling half (9) in elbow (7).
15. Apply a thin even coat of antiseize compound to cleaned external threads of two screws (10) before installation.
16. Fill pump (3) with oil.
17. Install retainer (11) and key (12) on pump (3).
18. Install new gasket (13) on pump (3).
19. Align key (12) in keyway of secondary drive gear. Secure pump (3) to transfer gearcase (14) with two new key washers (15) and screws (10).
20. Tighten two screws (10) to 35-40 lb-ft (47-54 N•m) torque. Use torque wrench.
21. Secure pump (3) to secondary drive gear with washer (16), nut (17), and new cotter pin (18).

NOTE

Two washers (16) are the maximum used. If two washers were removed, two will be installed.

22. Install washer(s) (16), to secure pump to drive gear.

23. Connect oil inlet hose (19) to quick disconnect coupling (9).
24. Connect oil outlet hose (20) to elbow (2).

BOTTOM ACCESS OPENING

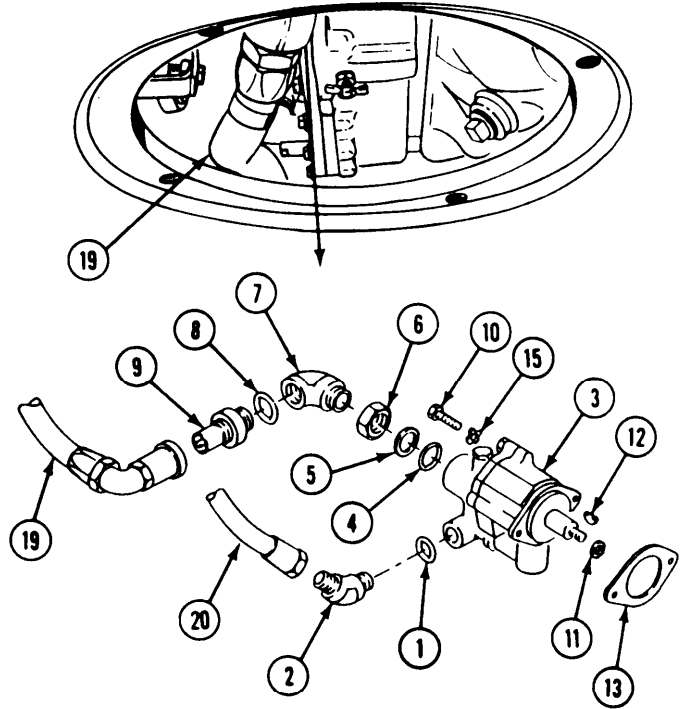

REAR COMPARTMENT ACCESS OPENING

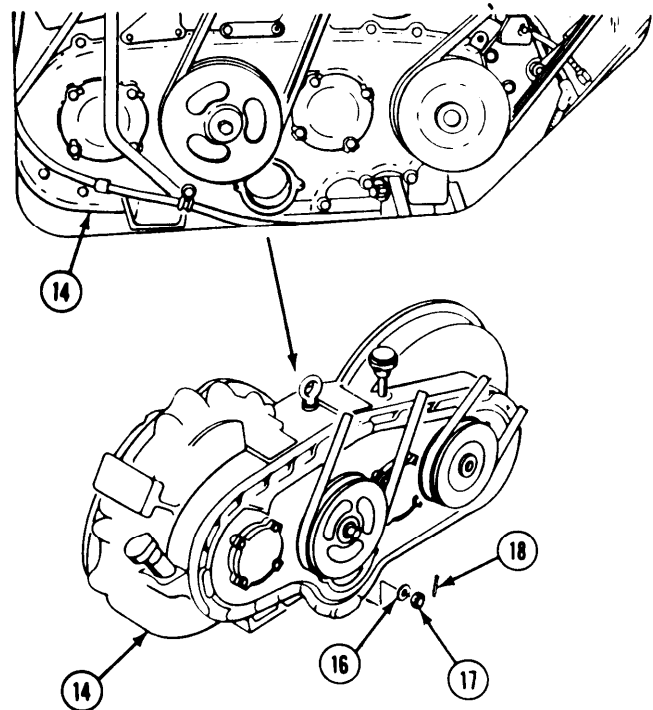

FOLLOW-THROUGH STEPS

1. Install ramp hydraulic pump (page 28-81).
2. Fill transfer gearcase (see your LO).

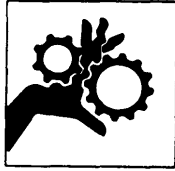

WARNING
Loose clothing is dangerous around moving belts and pulleys. You could get badly hurt if your clothes get caught in moving parts.

4. Stop/shutdown engine (see your -10).
 5. Install power plant rear access panel (page 24-27).
 6. Install power plant bottom access cover (page 24-32).
3. Start engine and raise ramp. Check that pump operates properly. Check for oil leaks (see your-10).

END OF TASK

REPLACE DIFFERENTIAL OIL FILTER AND FITTINGS

DESCRIPTION

This task covers: Remove (page 21-6). Clean, Inspect and Replace (page 21-6)
 Install (page 21-7).

INITIAL SETUP

Tools:

General Mechanics Tool Kit (Item 30, App D)
 Adjustable Wrench (Item 80, App D)

References:

see your -10
 See your LO

Material/Parts:

sealing compound (Item 51, App C)
 Lockwasher (2)
 Self-locking nut (2)
 Suitable Container

Equipment Conditions:

Engine stopped (see your -10)
 Carrier blocked (see your -10)
 Driver's power plant access panel removed
 (page 24-25)

Personnel Required:

Unit Mechanic

REMOVE

1. Place container under differential oil falter (1). Remove dram plug (2) to drain oil.
2. Disconnect inlet oil hose (3) from adapter (4).
3. Disconnect outlet hose (5) from elbow (6). Use adjustable wrench.
4. Remove two screws (7), locknuts (8), and washers (9). Remove falter (1) with oil falter head (10) and bracket (11) from engine. Discard locknuts.
5. Remove two screws (12), lockwashers (13), and bracket (11) from filter head (10). Discard lockwashers.
6. Remove adapter (4) from bushing (14).
7. Remove bushing (14) from oil filter head (10)
8. Remove elbow (6) from head (10).

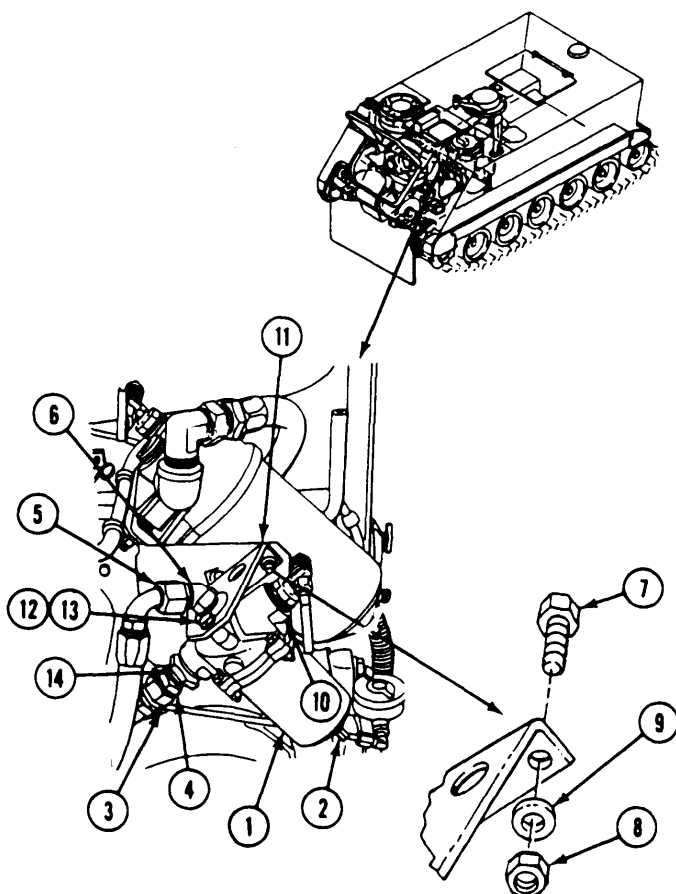

CLEAN, INSPECT AND REPLACE

9. Check fittings, hardware and hoses for cracks, damage and wear. Replace if needed.

INSTALL

10. Apply a thin even coat of sealing compound to cleaned external threads of all fittings before installation.
11. Install elbow (1) in oil filter head (2).
12. Install bushing (3) in head (2).
13. Install adapter (4) in bushing (3).
14. Install bracket (5) on head (2). Secure with two screws (6) and new lockwashers (7).
15. Install filter head (2) with bracket (5) on engine. Secure with two screws (8), washers (9), and new locknuts (10).
16. Connect outlet hose (11) to elbow (1). Use adjustable wrench.
17. Connect inlet hose (12) to adapter (4).
18. Install drain plug (13) in oil filter (14).

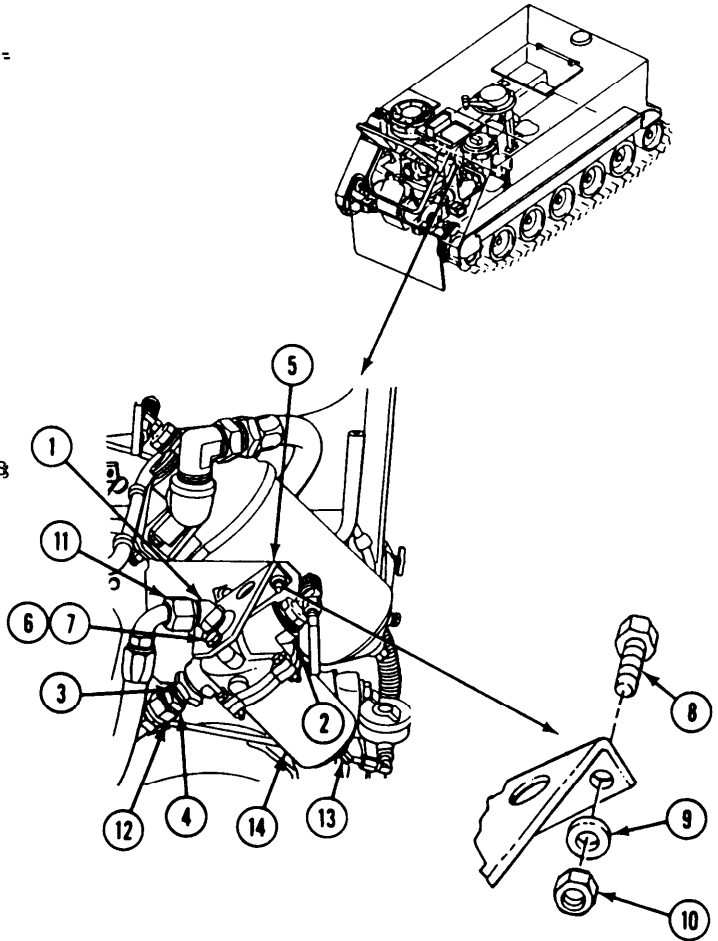

WARNING

Carbon monoxide is poisonous and can kill you. DO NOT idle engine with power plant panel off unless there is VERY GOOD AIR FLOW.



19. Check differential oil level (see your LO). Add oil as needed.
20. Start engine (see your -10). Check for leaks.

FOLLOW-THROUGH STEPS

1. Engine stopped/shutdown (see your -10).
2. Install driver's power plant access panel (page 24-25).

END OF TASK

REPLACE DIFFERENTIAL OIL FILTER ELEMENT

INITIAL SETUP

Tools:

General Mechanics Tool Kit (Item 30, App D)

Materials/Part:

Preformed packing
Self-locking nut (4)

Personnel Required:

Unit Mechanic

References:

See your -lo
See your LO

Equipment Conditions:

Engine stopped (see your -10)
Carrier blocked (see your -10)
Driver's power plant access panel removed
(page 24-25)

REMOVE

1. Remove four screws (1), locknuts (2), washers (3), and container (4) from filter head (5). Discard locknuts.
2. Remove preformed packing (6) from filter head (5). Discard packing.
3. Remove filter element (7) from container (4).

7. Start engine (see your -10). Check for oil leaks.
8. Check differential oil level (see your LO). Add oil if needed.

INSTALL

4. Install new filter element (7) in container (4).
5. Install new packing (6) in filter head (5).
6. Install container (4) on filter head (5). Secure with four screws (1), washers (3), and new locknuts (2).

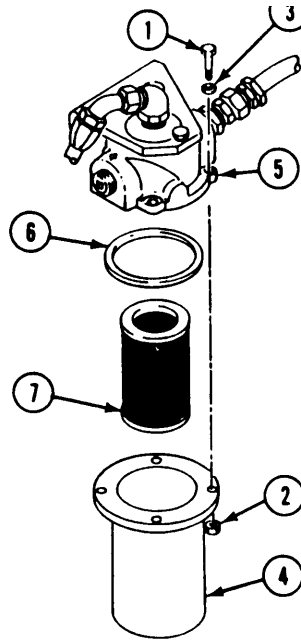

WARNING
Carbon monoxide is poisonous and can kill you. Do not idle engine with power plant panel off unless there is VERY GOOD AIR FLOW.

FOLLOW-THROUGH STEPS

1. Install driver's power plant access panel (page 24-25).
2. Engine stopped (see your -10).

END OF TASK

REPLACE DIFFERENTIAL OIL LEVEL DIPSTICK AND BREATHER

INITIAL SETUP

Tools:

General Mechanics Tool Kit (Item 30, App D)

Materials/parts:

Antiseize compound (Item 4, App D)

Personnel Required:

Unit Mechanic

References:

See your -10
See your LO

Equipment Conditions:

Engine stopped/shutdown (see your -10)
Carrier blocked (see your -10)
Trim vane lowered (see your -10)
Power plant front access door open
(see your -10)

REMOVE

1. Remove dipstick (1) from differential (2).
2. Remove breather (3) from differential (2).

CLEAN, INSPECT, AND REPLACE

3. Check parts and housing for cracks, wear, and damage. Replace if needed.

INSTALL

4. Apply a thin, even coat of antiseize compound to cleaned external threads of breather before installation.
5. Install breather (3) and dipstick (1) in differential (2).

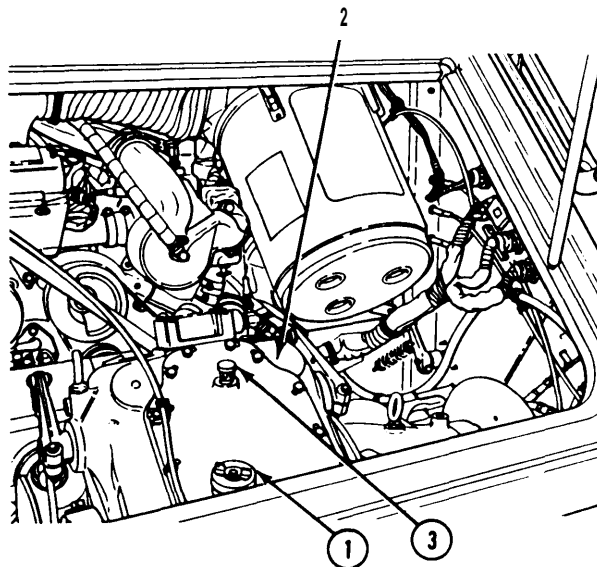

FOLLOW-THROUGH STEPS

1. Close power plant front access door (see your -10).
 2. Raise trim vane (see your -10).
-

END OF TASK

REPLACE DIFFERENTIAL OIL PUMP TO DIFFERENTIAL HOSE AND FITTINGS

DESCRIPTION

This task covers: Remove (page 21-11). Clean, Inspect, and Replace (page 21-12)
Install (page 21-12).

INITIAL SETUP

Tools:

- General Mechanics Tool Kit (Item 30, App D)
- Pipe wrench (item 86, App D)
- Suitable container

References:

- See your -10
- See your LO

Materials/Parts:

- Sealing compound (Item 59, App C)
- Preformed packing
- Self-locking nut

Equipment Conditions:

- Engine stopped/shutdown (see your -10)
- Carrier blocked (see your -10)
- Trim vane lowered (see your -10)
- Power plant front access door open (see your -10)
- Hull bottom access cover removed (page 24-32)

Personnel Required:

- Unit Mechanic

REMOVE

1. Drain differential oil into suitable container (see your LO).
2. Remove differential high oil temperature switch (page 15-4).
3. Disconnect differential oil hose quick disconnect coupling (1).
4. Disconnect differential oil hose (2) from elbow (3).
5. Remove elbow (3) from quick disconnect coupling half (4).
6. Remove quick disconnect coupling half (5) and preformed packing (6) from elbow (7). Discard packing.
7. Remove elbow (7), nut (8), retainer (9), and preformed packing (10) from differential oil pump (11). Discard packing.
8. Remove locknut (12), screw (13), washer (14), clamp (15), and differential oil hose (2) from hull crossbeam. Discard locknut.

9. Disconnect hose (2) from tee (16).
10. Remove tee (16) from bushing (17).
11. Remove bushing (17) from differential (18).

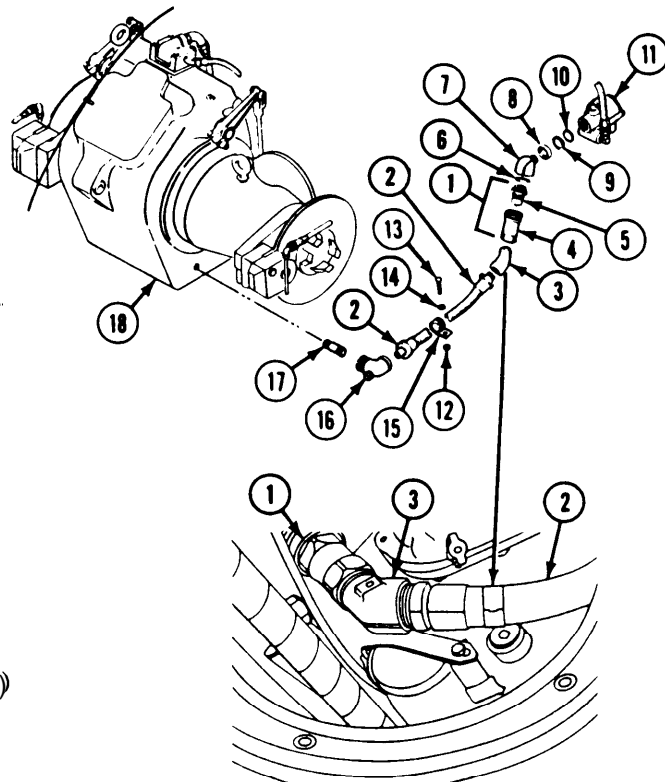

CLEAN, INSPECT, AND REPLACE

12. Check fittings, hardware, hoses and pump housing for leaks, cracks, damage and wear. Replace as needed.

INSTALL

13. Apply a thin even coat of sealing compound to cleaned threads of fittings before installation.
14. Install bushing (1) in differential (2).
15. Install tee (3) on bushing (1).
16. Connect differential oil hose (4) to tee (3).
17. Secure hose (4) to hull crossbeam with clamp (5), washer (6), screw (7), and new locknut (8).
18. Install new preformed packing (9), retainer (10), and elbow (11), in differential oil pump (12). Secure with nut (13).
19. Install quick disconnect half (14) and new packing (15) in elbow (11).
20. Install elbow (16) in quick disconnect half (17).
21. Connect hose (4) to elbow (16).
22. Connect oil hose quick disconnect coupling (18).

23. Install differential high oil temperature switch (page 15-4).
24. Fill differential with oil (see your LO).

WARNING

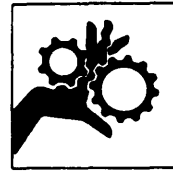

Loose clothing is dangerous around moving belts and pulleys. You could get badly hurt if your clothes get caught in moving parts.

25. Start engine (see your -10). Check for oil leaks.

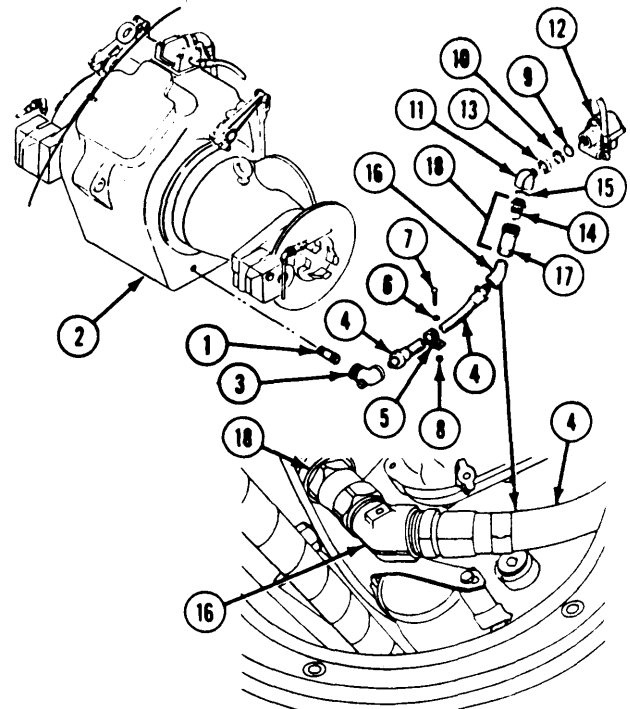

FOLLOW-THROUGH STEPS

1. Engine stopped/shutdown (see your -10).
2. Install hull bottom access cover (page 24-32).
3. Close power plant front access door (see your -10).
4. Raise trim vane (see your -10).

END OF TASK

REPLACE DIFFERENTIAL GEARBOX TO DIFFERENTIAL HOSE AND FITTINGS

DESCRIPTION

This task covers: Remove (page 21-12), Clean, Inspect and Replace (page 21-12).
Install (page 21-13)

INITIAL SETUP

Tools

General Mechanics Tool Kit (Item 30, App D)
Torque Wrench (Item 95, App D)

References:

See your -10
See your LO

Materials/Part:

Antiseize compound (Item 4, App C)
Sealing compound (Item 51, App C)
Self-locking nut

Equipment Conditions:

Engine stopped (see your -10)
Carrier blocked (see your -10)
Trim vane lowered (see your -10)
Power plant front access door open
(see your -10)

Personnel Required:

Unit Mechanic

REMOVE

1. Remove locknut (1), screw (2), and two clamps (3 and 4). Separate differential oil hose (5) from circuit 328 lead (6). Discard locknut.
2. Remove screw (7), washer (8), clamp (9), and oil hose (5) from differential (10).
3. Disconnect oil hose (5) from two elbows (11 and 12).
4. Remove elbow (11) from differential (10).
5. Remove elbow (12) from differential gearbox (13).

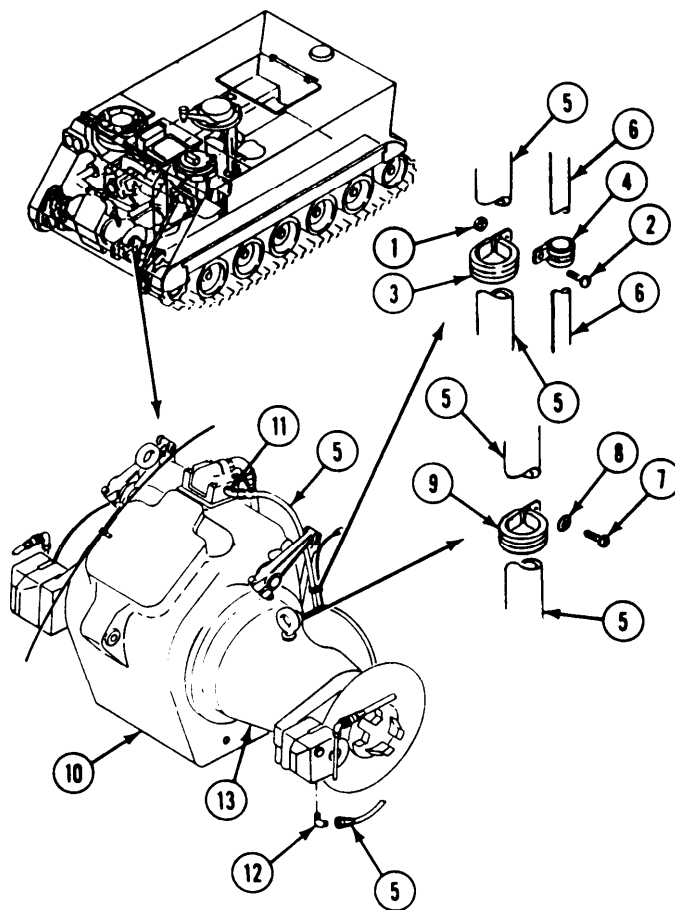

CLEAN, INSPECT AND REPLACE

6. Check fittings, hardware, hoses and differential housing for leaks, cracks, wear and damage. Replace as needed.

INSTALL

7. Apply a thin even coat of sealing compound to cleaned external threads of elbows (1 and 2).
8. Install elbow (2) in differential gearbox (3).
9. Install elbow (1) in differential (4).
10. Connect differential oil hose (5) to elbows (1 and 2).
11. Apply antiseize compound to external threads of screw (6).
12. Install oil hose (5) on differential (3) with clamp (7) and washer (8) secure with screw (6). Tighten screw (6) to 252–300 lb-in (28–34 N•m) torque, Use torque wrench.
13. Install circuit 328 lead (9) and oil hose (5) together with two clamps (10 and 11), and secure with screw (12) and new locknut (13).
14. Check differential oil level (see your LO). Add oil if needed.

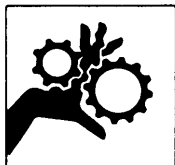
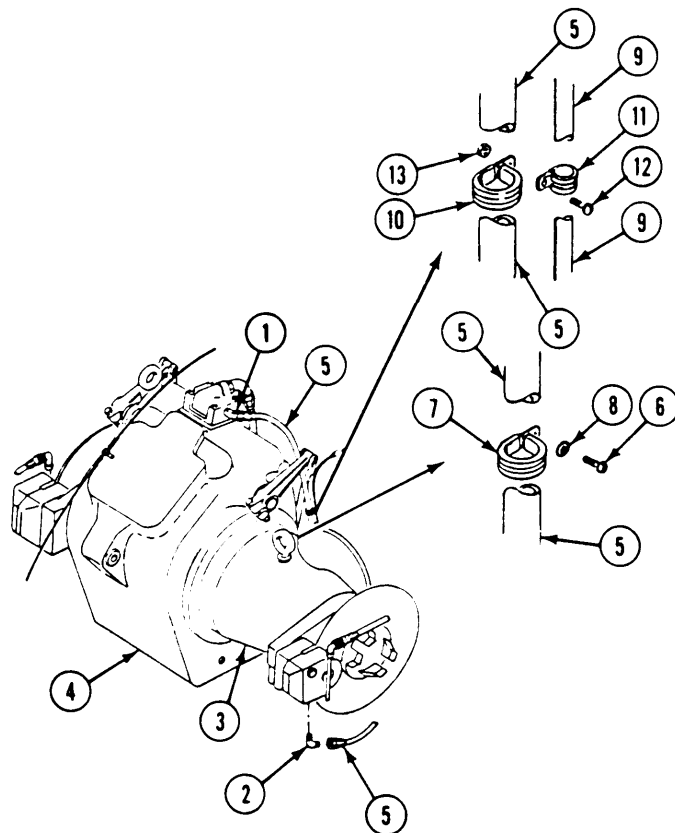

WARNING

Loose clothing is dangerous around moving belts and pulleys. You could get badly hurt if your clothes get caught in moving parts.

15. Start engine (see your -10). Check for leaks.

FOLLOW-THROUGH STEPS

1. Engine stopped (see your -10).
2. Close power plant front access door (see your -10).
3. Raise trim vane (see your -10).

END OF TASK

REPLACE DIFFERENTIAL TO OIL COOLER HOSE AND FITTINGS

DESCRIPTION

This task covers: Remove (page 21-14). Clean, Inspect, and Replace (page 21-15)
Install (page 21-15).

INITIAL SETUP

Tools:

General Mechanics Tool Kit (Item 30, App D)
Adjustable Wrench (Item 80, App D)

References:

see your -lo
See your LO

Material/Parts:

Primer N (Item 43, App C)
Sealing Compound (Item 46, App C)
Suitable Container

Equipment Conditions:

Engine stopped/shutdown (see your -10)
Carrier blocked (see your -10)
Hull bottom access cover removed
(page 24-32)
Trim vane lowered and power plant front
access door open (see your -10)
Driver's power plant access panel removed
(page 24-25)

Personnel Required:

Unit Mechanic

REMOVE

1. Drain oil from differential
(see your LO). Use suitable container.
2. Disconnect oil hose (1) from elbow (2) at differential.
3. Remove elbow (2) and adapter (3) from elbow (4).
4. If needed, remove elbow (4) from differential.
5. Disconnect oil hose (1) from elbow (5) at oil cooler (6).
6. Remove elbow (5) from oil cooler (6).
7. Remove screw (7) and clamp (8) from oil cooler (6).
8. Remove oil hose (1) from carrier.
9. Disconnect oil filter hose (9) from elbow (10).
10. Remove elbow (10) from oil cooler (6).
11. Disconnect filter hose (9) from elbow (11) on filter (12). Use adjustable wrench.

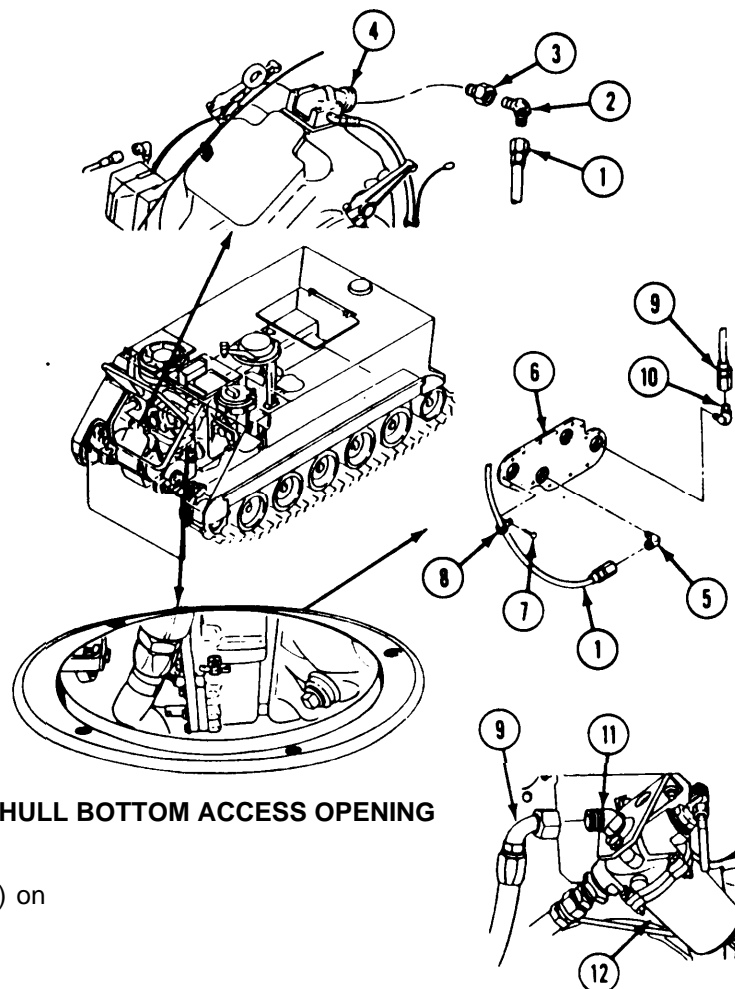

CLEAN, INSPECT, AND REPLACE

12. Check hoses, fittings, hardware, and differential housing for leaks, cracks, and wear. Replace as needed.

INSTALL

13. Install oil filter hose (1) in earner.
14. Connect filter hose (1) to elbow (2) on filter (3'). Use adjustable wrench.
15. Apply a thin coat of primer N and sealing compound only to threads of elbow (4) that are being installed into cooler (5).
16. Install elbow (4) in oil cooler (5).
17. Connect filter hose (1) to elbow (4).
18. Install hose (6) in carrier.
19. Install clamp (7) on hose (6). Secure clamp (7) to oil cooler (5) with screw (8).
20. Apply a thin coat of primer N and sealing compound only to threads of elbow (9) that are being installed into cooler (5).

21. Install elbow (9) at oil cooler (5).
22. Connect oil hose (6) to elbow (9) at oil cooler (5).
23. If removed, install elbow (10) in differential.
24. Apply a thin coat of primer N and sealing compound to external threads of adapter (11).
25. Install adapter (11) in elbow (10).
26. Apply a thin coat of primer N and sealing compound only to threads of elbow (12) that are being installed into adapter (11).
27. Install elbow (12) in adapter (11).
28. Connect oil hose (6) to elbow (12) at differential.
29. Fill differential (see your LO).
30. Start engine (see your -10). Check for oil leaks.

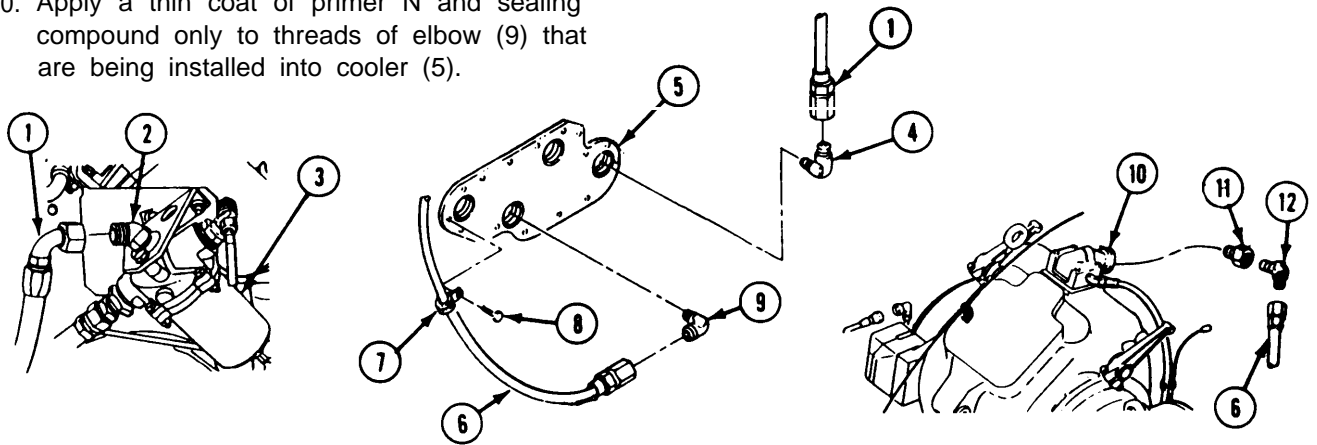

FOLLOW-THROUGH STEPS

1. Stop/shutdown engine (see your-10).
2. Install driver's power plant access panel (page 24-25).
3. Install hull bottom access cover (page 24-32).
4. Close power plant front access door and raise trim vane (see your -10).

END OF TASK

REPLACE DIFFERENTIAL OIL FILTER TO PUMP HOSE AND FITTINGS

DESCRIPTION

This task covers: Remove (page 21-16). Clean, Inspect; and Replace (page 21-17).
Install (page 21-17).

INITIAL SETUP

Tools:

General Mechanics Tool Kit (Item 30, App D)

Materials/Parts:

Sealing compound (Item 51, App C)
Preformed packing

Personnel Required:

Unit Mechanic

References:

see your -lo
See your LO

Equipment Conditions:

Engine stopped/shutdown (see your -10)
Carrier blocked (see your -10)
Driver's power plant access panel removed
(page 24-25)
Hull bottom access cover removed
(page 24-32)

REMOVE

1. Disconnect differential oil filter hose (1) from adapter (2).
2. Remove adapter (2) from bushing (3).

3. Remove bushing (3) from differential oil filter (4).
4. Disconnect differential oil filter hose (1) from elbow (5).
5. Remove elbow (5) and preformed packing (6) from differential oil pump (7). Discard packing.

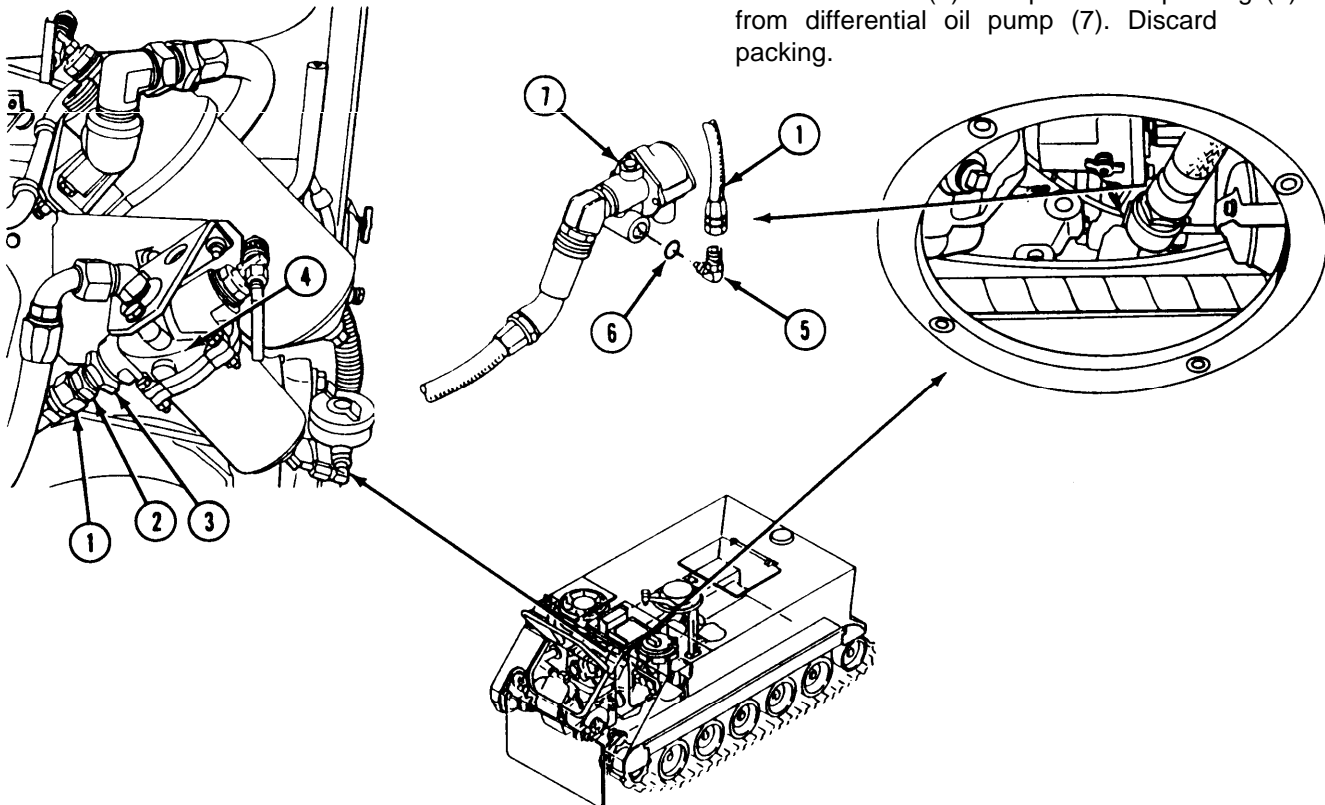

CLEAN, INSPECT, AND REPLACE

6. Check fittings, hardware, housing and hoses for leaks, cracks, damage and wear. Replace as needed.

INSTALL

7. Apply a thin, even coat of sealing compound to cleaned external threads of fittings before installation.
8. Install new preformed packing (1) and elbow (2) in differential oil pump (3).
9. Connect differential oil filter hose (4) to elbow (2).
10. Install bushing (5) in differential oil filter (6).
11. Install adapter (7) in bushing (5).
12. Connect filter hose (4) to adapter (7).
13. Check differential oil level (see your LO). Add oil if needed.

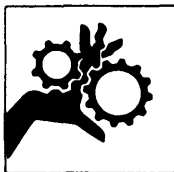
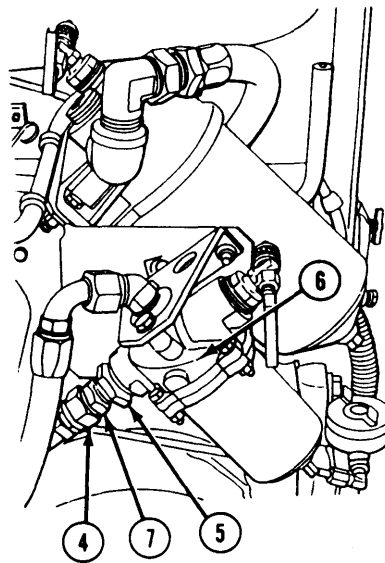
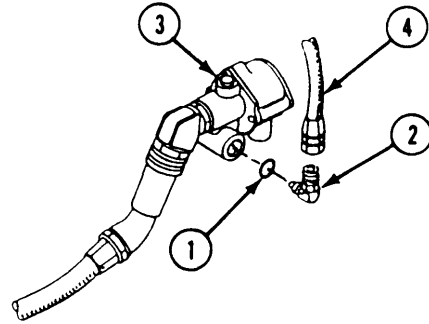

WARNING
Loose clothing is dangerous around moving belts and pulleys. You could get badly hurt if your clothes get caught in moving part.

14. Start engine (see your -10). Check for leaks.

FOLLOW-THROUGH STEPS

1. Engine stopped/shutdown (see your -10).
2. Install driver's power plant access panel (page 24-25).
3. Install hull bottom access cover (page 24-32).

END OF TASK

DIFFERENTIAL BRAKE ADJUSTMENT

INITIAL SETUP

Tools:

General Mechanics Tool Kit (Item 30, App D)
Weighing Scale (Item 61, App D)

References:

See your -10
See your Lo

Materials/Parts:

Antiseize compound (Item 4, App C)

Equipment Conditions:

Engine stopped/shutdown (see your -10)
Carrier blocked (see your -10)
Trim vane lowered and power plant front access door open (see your -10)

Personnel Required:

Unit Mechanic
Helper (H)

ADJUST

NOTE

Do not try to adjust steering linkage to compensate for brake lining wear. Uneven steering lever pull will result.

Adjust differential brakes only when differential is cool. You cannot get a good adjustment if differential is hot.

Check steering lever pawl adjustment (page 23-5) and steering brake linkage adjustment (page 23-3) before making differential brake adjustment.

1. Place two differential steering levers (1) in full forward released position.
2. Remove two access plugs (2) from differential housing.

CAUTION

Make sure socket is taped to extension to prevent socket from falling into the differential.

3. Insert socket (3) through differential access holes. Turn each differential brake band adjusting nut (4) one detent at a time. Turn left to tighten band or right to loosen.
4. Place steering levers (1) in second notch from front of quadrants (5).
5. Using a strap or rope, attach dial scale (6) to center of steering lever hand grip.

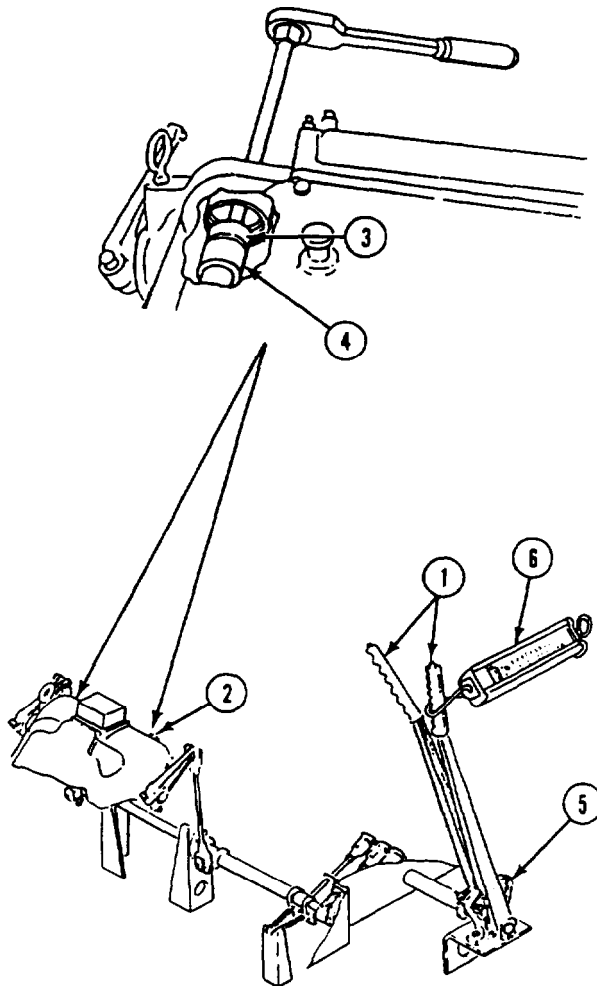

- 5.1. Pull back on both steering levers (1) very hard to ensure brake adjusting nut is on the bottom of cam.
6. Pull dial scale rearward.
7. A pull of 10-30 pounds (4.5-14 kg) on dial scale (2) should cause steering lever handle button to pop up. Steering lever (1) will then move forward to release position.
8. Repeat adjusting procedure until you get correct release pressure.
9. If adjustment cannot be obtained, notify direct support maintenance.
10. If you cannot get correct release pressure, notify direct support maintenance.
11. Remove socket (3) through differential access hole.
12. Apply a thin even coat of antiseize compound to threads of two access plugs (4).
13. Install two access plugs (4) in differential housing.

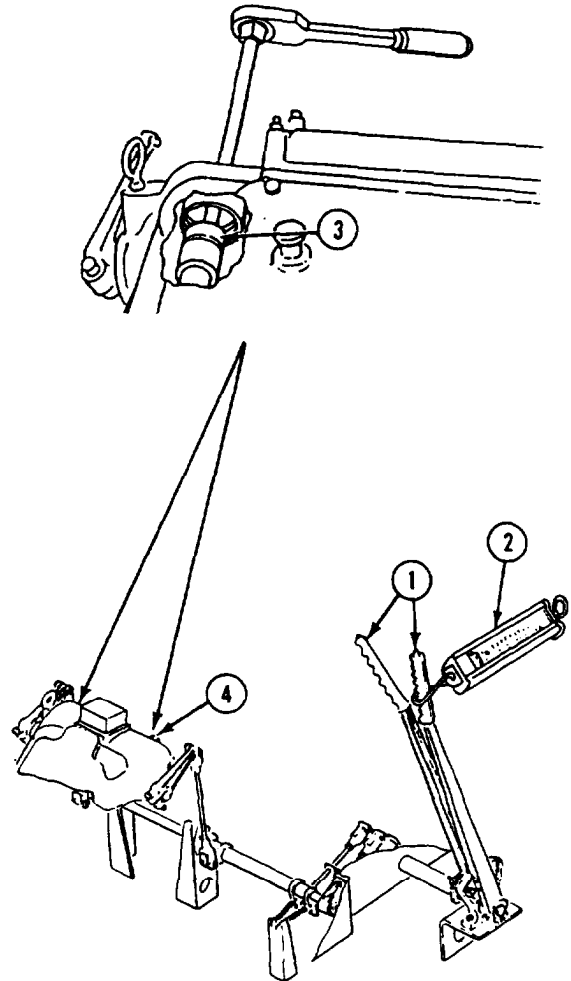

FOLLOW-THROUGH STEPS

1. Close power plant front access door and raise trim vane (see your -10).
 2. Operate carrier (see your -10). Check that steering brakes are operable.
-

END OF TASK

REPLACE DIFFERENTIAL AND MOUNTS

DESCRIPTION

This task covers: Remove (page 21-20). Install (page 21-21).

INITIAL SETUP

Tools:

General Mechanics Tool Kit (Item 30, App D)
 Remover and Replacer (Item 55, App D)
 Sling (Item 66, App D)

Materials/Parts:

Self-locking nut

Personnel Required:

Unit Mechanic
 Helper

References:

See your -10
 See your LO

Equipment Conditions:

Engine stopped/shutdown (see your -10)
 Power plant access door open (see your -10)
 Carrier blocked (see your -10)

Equipment Conditions: (cont):

Battery ground leads disconnected (page 13-2)
 Air cleaner housing removed (page 7-7)
 Radiator outlet coolant tube removed
 (page 8-14)
 Exhaust pipe removed (page 7-16)
 Deaeration elbow removed (page 8-15)
 Transmission to differential shaft removed
 (page 20-2)
 Left final drive shaft removed (page 20-5)
 Right final drive shaft removed (page 20-7)
 Differential oil pump hose disconnected at
 differential (page 21-10)
 Differential oil cooler hose disconnected at
 differential (page 21-14)
 Differential brake linkage removed
 (page 23-19)
 Differential steering brake levers removed
 (page 23-20)
 Fuel shutoff cable disconnected from engine
 (page 23-44)

REMOVE

1. Remove screw (1), locknut (2), clamp (3), and fuel shutoff cable (4) from bracket (5). Discard locknut.
2. Disconnect two pivot steer hydraulic hoses at two quick disconnect couplings (6).
3. Disconnect differential high oil temperature switch lead (7) from main wiring harness.

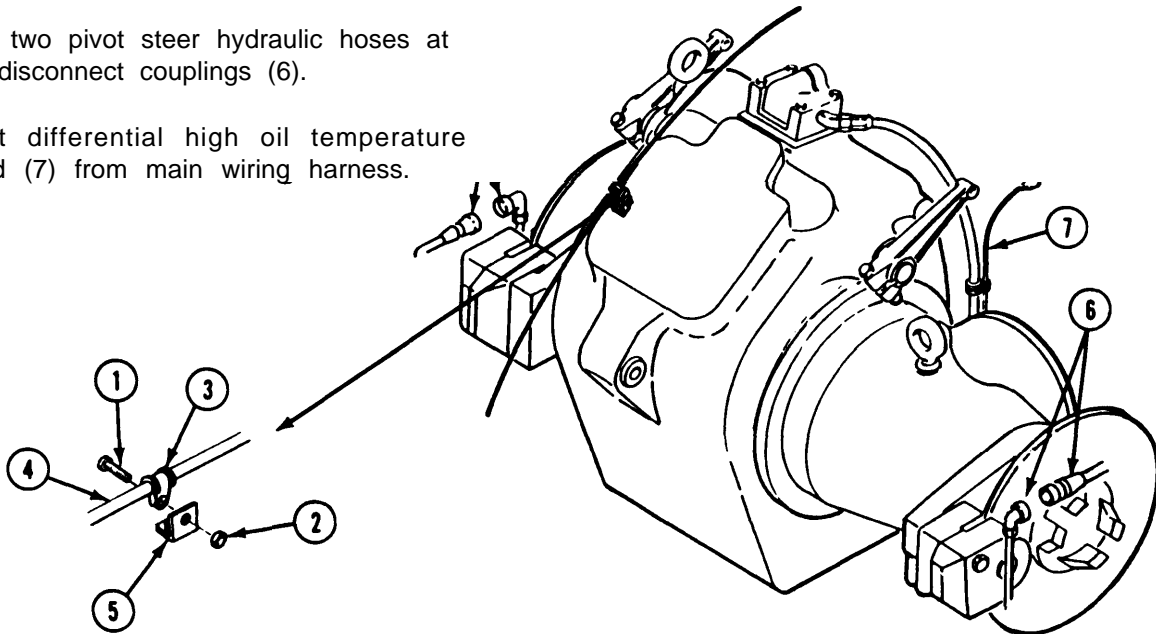

4. Disconnect three power plant wiring harness connectors (1) from driver's compartment bulkhead.



w a r n i n g
The differential is heavy.
Have helper help you or use
a lifting device.

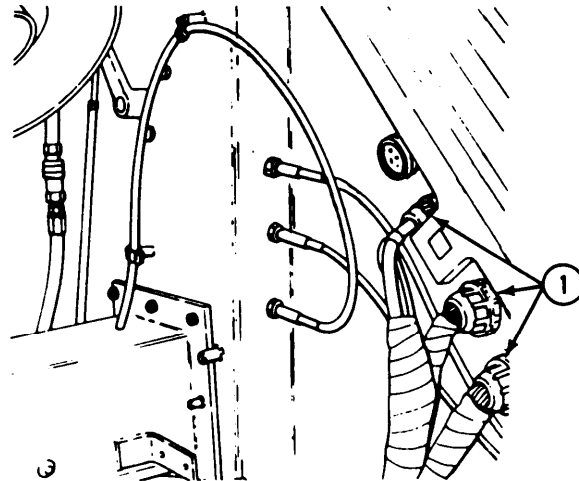

5. Attach a suitable lifting device of at least 600 lb. (227 kg) capacity and lifting sling (2) to two differential lifting eyes.
6. Remove three retaining clips (3) and three pins (4) from differential hull mounts.
7. Remove differential (5) from carrier.
8. Remove three mounts (6) from differential (5), using remover and replacer (7).

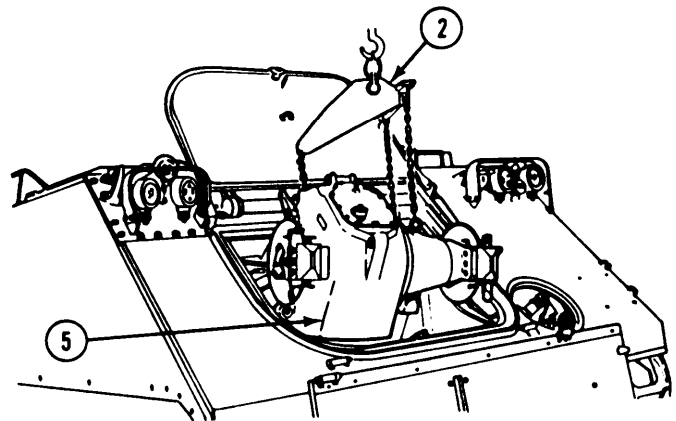

INSTALL

9. Install three mounts (6) in differential (5). Use remover and replacer (7).
10. Attach a suitable lifting device of at least 500 lb. (227 kg) capacity and lifting sling (2) to two differential lifting eyes.
11. Lower differential into carrier.
12. Install three pins (4) through differential and hull mounts. Secure with three retaining clips (3)
13. Remove lifting sling (2) from differential (5).
14. connect three power plant wiring harness connectors (1) at driver's compartment bulkhead.

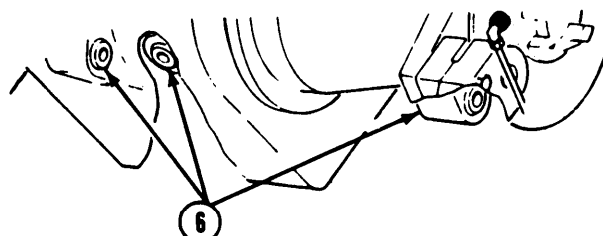
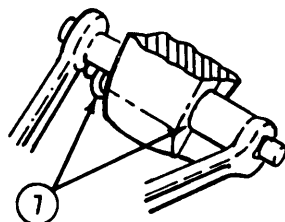
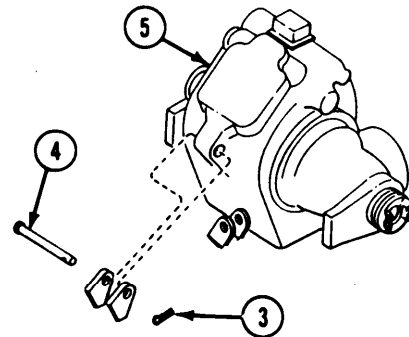

15. Connect differential high oil temperature switch lead (1) to main wiring harness.
16. Connect two pivot steer hydraulic hoses to two quick disconnect couplings (2).
17. Install fuel shutoff cable (3) on bracket (4). Secure with clamp (5), new locknut (6), and screw (7) .

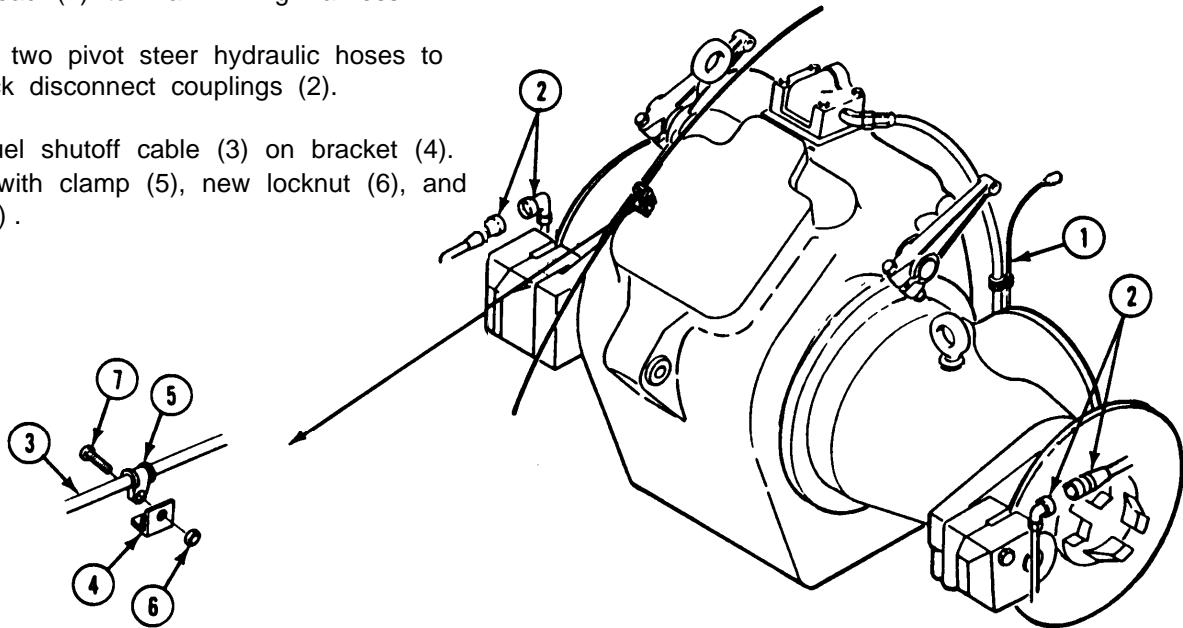

FOLLOW-THROUGH STEPS

- | | |
|---|---|
| <ol style="list-style-type: none"> 1. Install differential steering brake levers (page 23-20). 2. Connect differential oil cooler hose (page 21-14). 3. Connect differential oil pump hose (page 21-10). 4. Fill differential with oil (see your LO). 5. Install right final drive shaft (page 20-7). 6. Install left final drive shaft (page 20-5). 7. Install differential brake linkage (page 23-19). 8. Install transmission to differential shaft (page 20-2). 9. Install deaeration elbow (page 8-15). | <ol style="list-style-type: none"> 10. Install exhaust pipe (page 7-16). 11. Install radiator outlet coolant tube (page 8-14). 12. Fill cooling system (page 8-5). 13. Install air cleaner housing (page 7-7). 14. Connect fuel shutoff cable to engine and adjust cable (page 23-44). 15. Close power plant front access door (see your -10). 16. Raise trim vane (see your -10). 17. Connect battery ground cable (page 13-2). 18. Operate carrier (see your -10). Check that differential is operable. 19. Engine stopped/shutdown (see your -10). |
|---|---|

END OF TASK

REPLACE DIFFERENTIAL GASKET

DESCRIPTION

This task covers: Remove (page 21-23). Install (page 21-24).

INITIAL SETUP

Tools:

General Mechanics Tool Kit (Item 30, App D)
Socket (Item 89, App D)
Torque Wrench (Item 95, App D)

Materials/Parts:

Antiseize compound (Item 4, App C)
Dry cleaning solvent (Item 13, App C)
Key washer (14)
Wiping rag (Item 61, App C)
Gasket

Personnel Required:

Unit Mechanic

References

See your -10
See your LO

Equipment Conditions:

Engine Stopped. See your -10.
Carrier Blocked. See your -10.
Front Power Plant Engine Access Door Open:
See your -10.

REMOVE

1. Remove dipstick (1) from differential cover (2).

NOTE

Damage to differential may occur if dirt or debris falls into it while cover is off. Before differential cover is removed, all dirt and debris must be removed from around it and power plant door.

2. Remove all dirt and debris from around and above differential cover (2).
3. Straighten tabs on 14 key washers (3).
4. Remove 14 screws (4) key washers (3), differential cover (2), and gasket (5) from differential gearbox (6) Discard gasket and key washers.

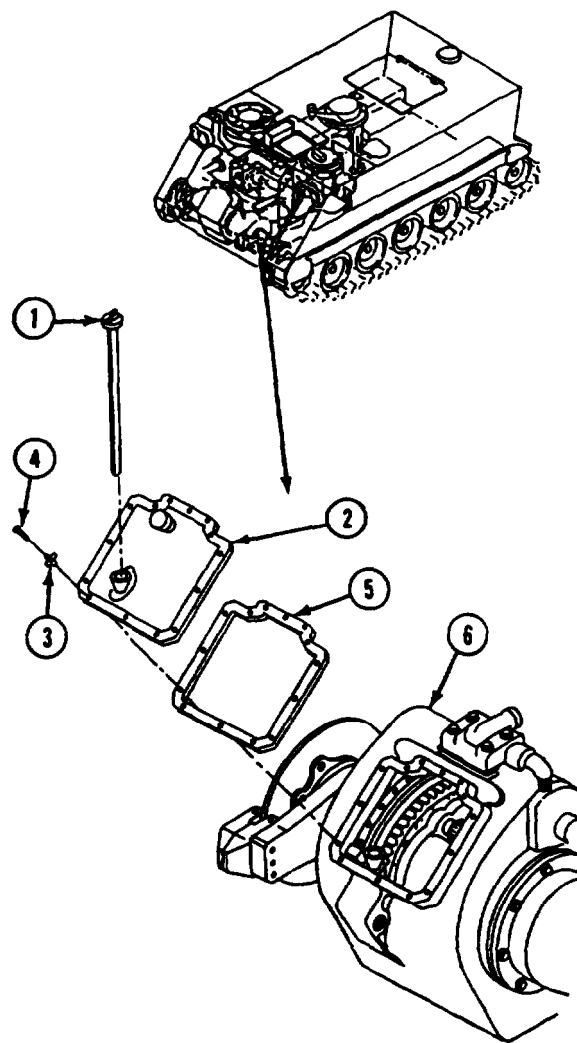

GO TO NEXT PAGE

INSTALL

5. Clean threads of 14 screws (1) with dry cleaning solvent.
6. Apply light coat of antiseize compound to threads of 14 screws (1).
7. Place new gasket (2) and new differential cover (3) on differential gearbox (4).
8. Secure differential cover (3) in place with 14 new key washers (5) and screws (1). Tighten screws to 252-300 lb-in (29-34 N-m) torque. Bend tabs on key washers.
9. Install dipstick (6) through differential cover (3).

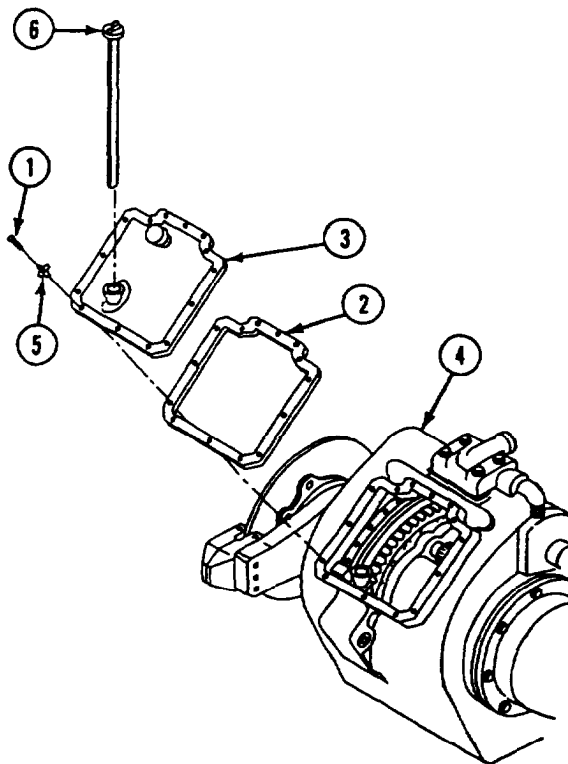

FOLLOW-THROUGH STEPS

1. Check oil level in differential gearbox. See your LO.
2. Close front power plant engine access door. See your -10.

END OF TASK

CHAPTER 22
TRACKS AND SUSPENSION MAINTENANCE

TASK INDEX

<u>Task</u>	<u>Page</u>	<u>Task</u>	<u>Page</u>
Replace 12 Inch (30 CM) Track Shroud and Covers.	22-2	Replace Idler Wheel Arm Assembly (All Except M741A1).	22-20
Replace Track.	22-4	Replace Idler Wheel Arm (M741A1 Only).	22-22
Replace Track Shoe and Pad Assembly.	22-6	Replace Track Tension Adjuster and Mount.	22-24
Replace Road Wheel.	22-7	Replace Shock Absorber.	22-26
Replace Road Wheel Hub.	22-9	Replace Shock Absorber Pin.	22-28
Replace Road Wheel Support h-m. Bearings, and Seals.	22-12	Replace Shock Absorber Mount.	22-29
Replace Road Wheel Support Arm Bumper Stop (M741A1 Only).	22-15	Replace Drive Sprockets, Cushions, and Carrier Assembly.	22-30
Replace Idler Wheel.	22-16	Replace Torsion Bar.	22-32
Replace Idler Wheel Arm Bearings and Seals.	22-17	Replace Torsion Bar Anchor.	22-36

REPLACE 12 INCH (30 CM) TRACK SHROUD AND COVERS

DESCRIPTION

This task covers: Remove (page 22-2). Clean, Inspect, and Replace. (page 22-3)
Install (page 22-3).

INITIAL SETUP

Tools:

- General Mechanics Tool Kit (Item 30, App D)
- Track fixture (Item 26, App D)

Personnel Required:

- Unit Mechanic

References:

- see your -10

Equipment Conditions:

- Engine stopped/shutdown (see your -10)
- Carrier blocked (see your -10)

REMOVE

NOTE

Left side of shroud is shown in this task. Perform the same steps for the right shroud.

1. Connect track fixture between fender and rear shroud cover (1).
2. Tighten fixture to relieve tension on four screws (2). Remove four screws (2) and washers (3) from rear shroud cover (1).
3. Remove track fixture.

4. Remove four screws (4) and washers (5) from front shroud cover (6).
5. Remove eight screws (7), washers (8), two clamps (9) and two shroud covers (1 and 6) from shroud (10).
6. Remove eight screws (11), washers (12), two clamps (13) and shroud (10) from hull.

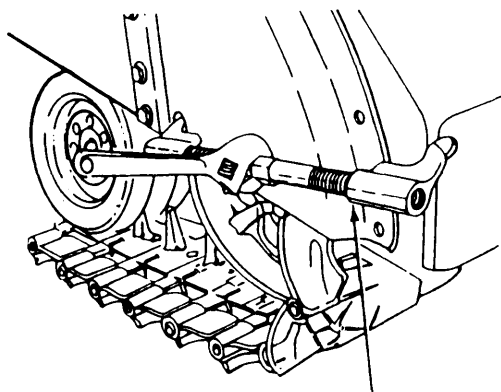

FIXTURE
5120-01-041-4624

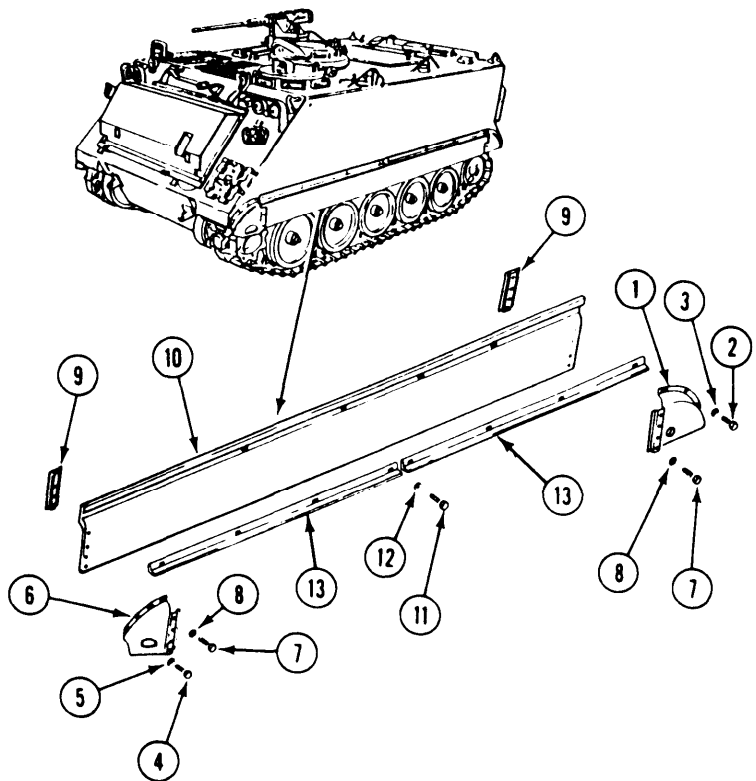

CLEAN, INSPECT, AND REPLACE

7. Check clamps for cracks, wear, and damage. Replace if needed.
8. Inspect rubber for cracks, wear, and dry rotting. Replace if needed (see page 22-4).
9. Inspect tapped holes in hull for dirt or foreign material. Clean all tapped holes if dirty to prevent damage to screw threads.

INSTALL

10. Place shroud (1) on hull. Secure with two clamps (2), eight washers (3) and screws (4),

11. Place two shroud covers (5 and 6) on shroud (1). Secure with two clamps (7), eight washers (8) and screws (9).
12. Place front shroud cover (6) on hull. Secure with four washers (10) and screws (11).
13. Connect track fixture between rear shroud cover (5) and fender. Tighten fixture to align holes in shroud cover with holes in fender.
14. Secure rear shroud cover (5) to fender with four washers (12) and screws (13). Remove track fixture.

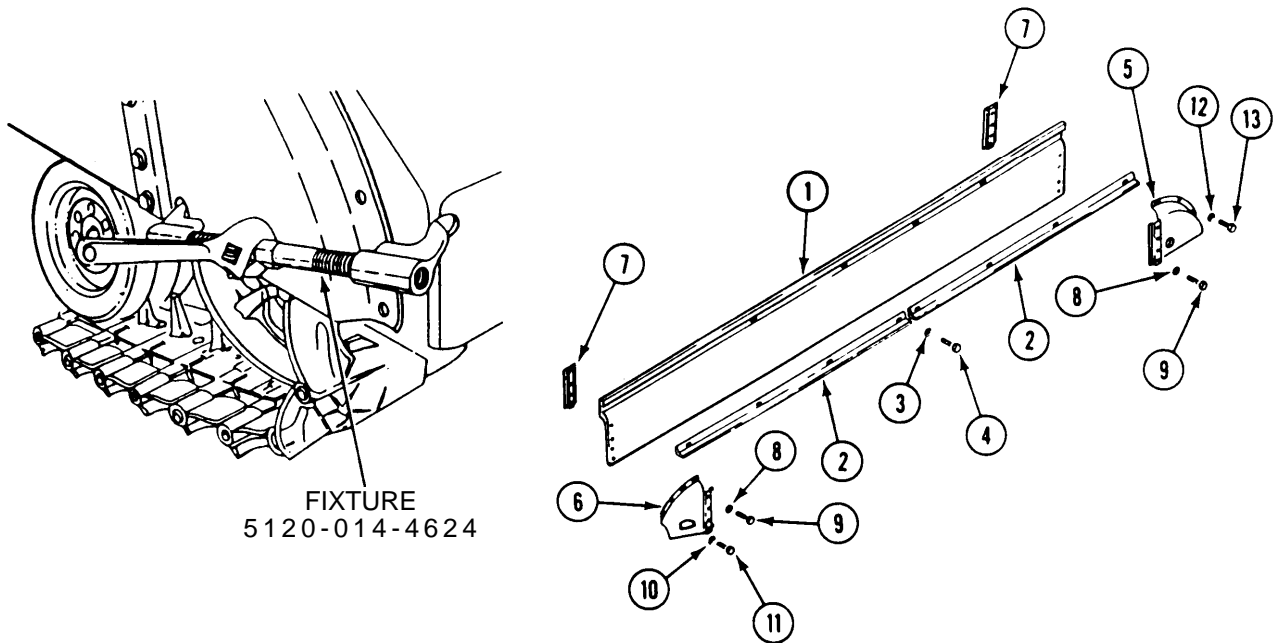

FOLLOW-THROUGH STEPS

1. Carrier unblockd (see your -10).
2. Start engine. Road test earner (page 2-45) to ensure track shroud and cover are installed properly.
3. Stop/shutdown engine (see your -10).

END OF TASK

REPLACE TRACK

DESCRIPTION

This task covers: Remove (page 22-4). Clean, Inspect, And Replace. (page 22-5)
Install (page 22-5).

INITIAL SETUP

Tools:

General Mechanics Tool Kit (Item 30, App D)
Track Fixture (2) (Item 26, App D)
Track and Sprocket Gage (Item 29, App D)
Drive Pin Punch (Item 50, App D)
Torque Wrench (Item 96, App D)

Personnel Required:

Unit Mechanic
Helper (H)

References:

see your -10

Equipment Conditions:

Engine stopped/shutdown (see your -10)
Carrier blocked (see your -10)
Track shroud and covers removed (page 22-2)

REMOVE

1. Relieve tension and break track (see your -10).
2. Remove blocks used to keep carrier from moving (see your -10).
3. Start engine (see your -10). Place range selector in R position. Slowly back carrier (see your -10).
4. (H) Guide track (1) over drive sprockets (2), road wheels (3), and idler wheel (4).
5. After carrier clears track (1), lock steering lever (see your -10). Place range selector in N position. Stop engine (see your -10).

WARNING



Failure to lock steering laterals and block the road wheels can allow the carrier to move and could result in injury or death. Always lock steering laterals and block road wheels before working on the earner.

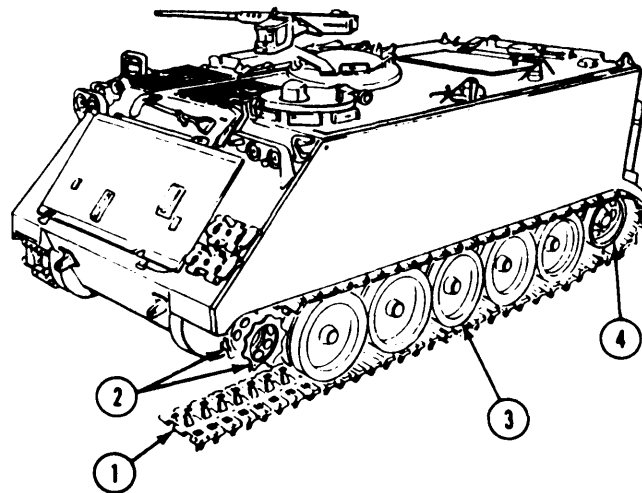

6. Block earner (see your -10).

NOTE

Make sure track pads point toward vehicle.

CLEAN, INSPECT, AND REPLACE

7. Check for damage, wear, and cracks. Replace as needed.
8. (H) Lay track (1) out flat in front of earner so that track guides are aligned between first pair of road wheels (3).
9. Remove blocks used to keep carrier from moving (see your -10).
10. Start engine (see your -10). Place range selector in 1 DRIVE. Slowly drive carrier forward (see your -10).
11. (H) Pull track (1) up and over idler wheel (4), road wheels (3), and drive sprocket (2).
12. Stop carrier when hub of first road wheel is directly over third track shoe from the end of the track.
13. Place range selector in N. Stop engine (see your -10).

**WARNING**

Failure to lock steering laterals and block the road wheels can allow the carrier to move and could result in injury or death. Always lock steering laterals and block road wheels before working on the carrier.

14. Block carrier (see your -10).
15. Connect track and torque track pin nut to 115-135 lb-ft (156-183 N•m). Use torque wrench.
16. Adjust tension (see your -10).

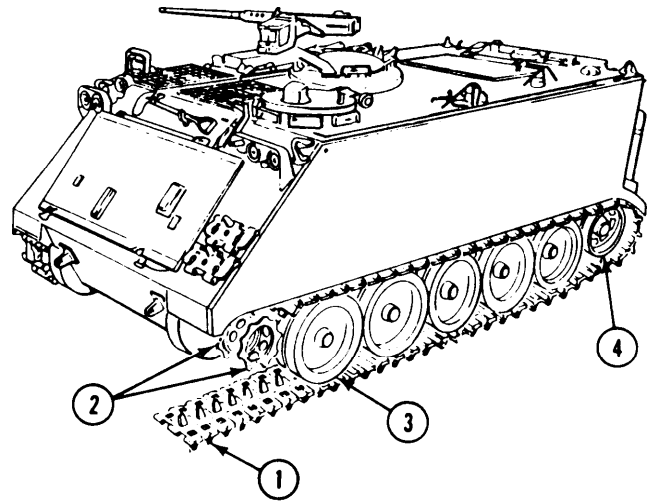
**FOLLOW-THROUGH STEPS**

1. Install track shroud and cover (page 22-2).
2. Road test earner (page 2-45) to check that track is installed properly.
3. Stop/shutdown engine (see your -10).

END OF TASK

REPLACE TRACK SHOE AND PAD ASSEMBLY

INITIAL SETUP

Tools:

- General Mechanics Tool Kit (Item 30, App D)
- Torque Wrench (Item 96, App D)

References:

see your -10

Materials/Parts:

- Self-locking nut

Equipment Conditions:

- Carrier on level ground
- Carrier positioned with track pad accessible
- Engine stopped/shutdown (see your -10)
- Carrier blocked (see your -10)
- Track shroud and covers removed (page 22-2)

Personnel Required:

- Unit Mechanic

REPLACE

1. See your -10 for instructions on replacing the track shoe.

NOTE

Track shoe pin should not be extending outside of shoe.

2. Tighten either locknut (1) on track shoe pin (z) until approximately 1-2 threads extend through locknut. Tighten opposite locknut (1) to 115-135 lb-ft (155-183 N•m). Use torque wrench.

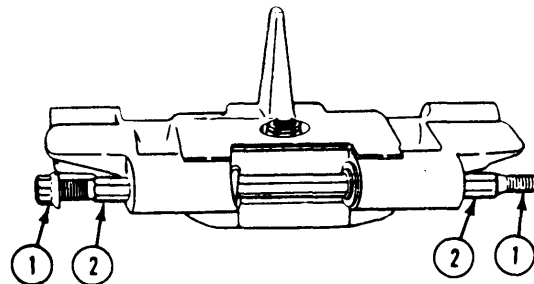

REMOVE

3. Remove locknut (3) and pad (4) from track shoe (5). Discard locknut.

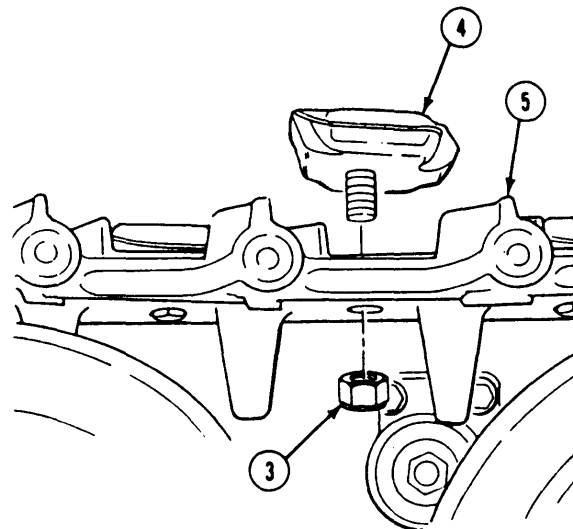

INSTALL

NOTE

Your carrier might have either T130 or T130E1 track, or a mixture of both. A T130E1 track pad is about 4-3/4 inches (12 cm) long. A T130 track pad is about 6-3/4 inches (14.6 cm) long.

4. Install track shoe pad (4) in track shoe (5). Secure with new locknut (3). Tighten locknut to 135-155 lb-ft (183-210 N•m torque). Use torque wrench.

FOLLOW-THROUGH STEPS

1. Install track shroud and covers (page 22-2).

END OF TASK

REPLACE ROAD WHEEL

DESCRIPTION

This task covers: Remove (page 22-7). Install (page 22-8).

INITIAL SETUP

Tools:

- General Mechanics Tool Kit (Item 30, App D)
- Road Wheel Lifter (Item 39, App D)
- Torque Wrench (Item 96, App D)
- Lifting Bar (Item 12, App D)

References:

- See your -10
- TM 9-2530-200-24

Material/parts:

- Self-locking nut, per wheel (8)

Equipment Conditions:

- Carrier on level surface
- Engine stopped/shutdown (see your -10)
- Carrier blocked (see your -10)
- Track shroud and covers removed (page 22-2)
- Release track tension (see your -10)

Personnel Required:

- Unit Mechanic
- Helper (H)

REMOVE

1. (H) Place lifter (1) under road wheel arm (2). Keep lower tips of lifter in track link just rearward of wheel being removed.
2. Loosen eight locknuts (3) on road wheel (4). Do not remove locknuts.
3. Remove blocks used to keep earner from moving (see your -10).



WARNING

Failure to lock steering laterals and block the road wheels can allow the carrier to move and could result in injury or death. Always lock steering laterals and block road wheels before working on the earner.

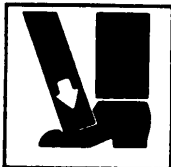

WARNING

If road wheel lifter slips while lowering road arm, it could injure you. Stand clear before you lower road arm.

7. Remove eight locknuts (3) and washers (5) from road wheel (4). Discard locknuts.
8. Lift track with bar until track clears road wheel (4). Remove two road wheels.

4. Start engine (see your -10). Place gear selector in R position. Slowly back carrier until lifter (1) is vertical and road wheel (4) clears ground.
5. Stop engine and lock steering laterals (see your -10).
6. Block carrier (see your -10),

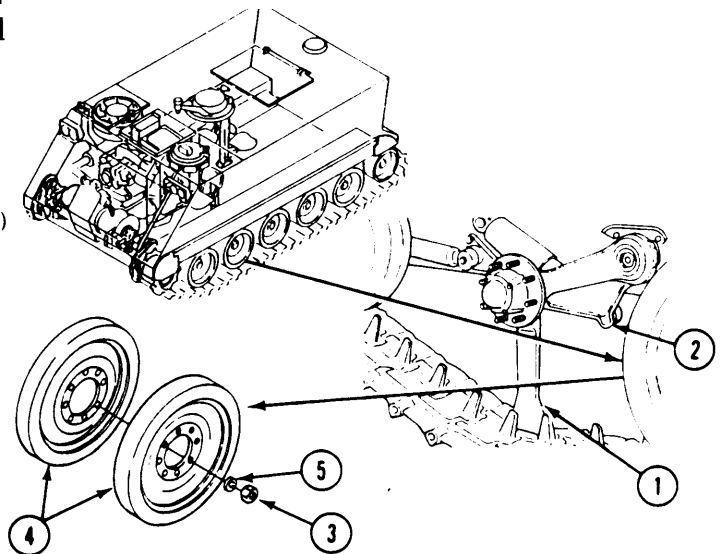

GO TO NEXT PAGE

INSTALL

9. Lift track assembly with bar. Place two road wheels (1) on road wheel arm (2). Secure loosely with eight washers (3) and new locknuts (4).
10. Remove blocks used to keep earner from moving (see your -10).



WARNING
You can be hurt if road wheel lifter slips while road arm is being lowered. Stand clear.



WARNING
Failure to lock steering laterals and block the road wheels can allow the carrier to move and could result in injury or death. Always lock steering laterals and

block road wheels before working on the earner.

12. Block carrier (see your -10).
13. Tighten eight locknuts (4) to 150-170 lb-ft (203-230 N•m) torque. Use torque wrench.

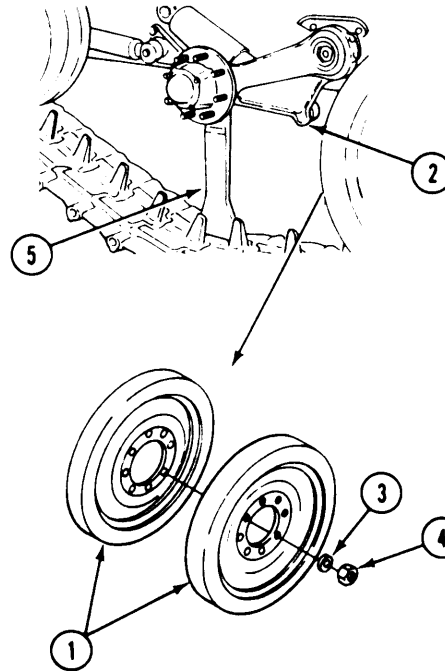

FOLLOW-THROUGH STEPS

1. Adjust track tension (see your -10).
2. Install track shroud and covers (page 22-2).
3. Road test earner (page 2-45) to check that road wheel is installed properly.

END OF TASK

REPLACE ROAD WHEEL HUB

DESCRIPTION

This task covers: Remove (page 22-9). Clean, Inspect, and Replace (page 22-10).
Install (page 22-10).

INITIAL SETUP**Tools:**

General Mechanics Tool Kit (Item 30, App D)
 Replacer (Item 56, App D)
 Ring Spacer (Item 70, App D)
 Torque Wrench (Item 96, App D)

Materials/Parts:

Grease (Item 18, App C)
 Sealing compound (Item 47, App C)
 Cotter pin
 Hub cap gasket
 HuD-to-arm seal
 Inner bearing (as needed)
 Inner bearing cup (as needed)
 Outer bearing (as needed)
 Outer bearing cup (as needed)
 Ribbed shoulder bolt (as needed)

Personnel Required:

Unit Mechanic

References:

See your -10
 See your LO
 TM 9-214

Equipment Conditions:

Carrier on level surface
 Engine stopped/shutdown (see your -10)
 Carrier blocked (see your -10)
 Track shroud and covers removed (page 22-2)
 Road wheel removed (page 22-7)

REMOVE

1. Remove four screws (1), hub cap (2), and gasket (3) from road wheel hub (4). Discard gasket.
2. Remove cotter pin (5), nut (6), and washer (7) from road wheel support arm (8). Discard cotter pin.
3. Remove outer bearing (9) and hub (4) from road wheel support arm (8). Remove seal (10) and inner bearing (11) from hub (4). Discard seal.
4. Remove grease fitting (12) and relief valve (13) from hub (4).
5. If damaged, remove bolt(s) (14) from hub (4). Discard bolt(s).
6. If damaged, remove bearing cups (15 and 16) from hub (4). Discard cups.

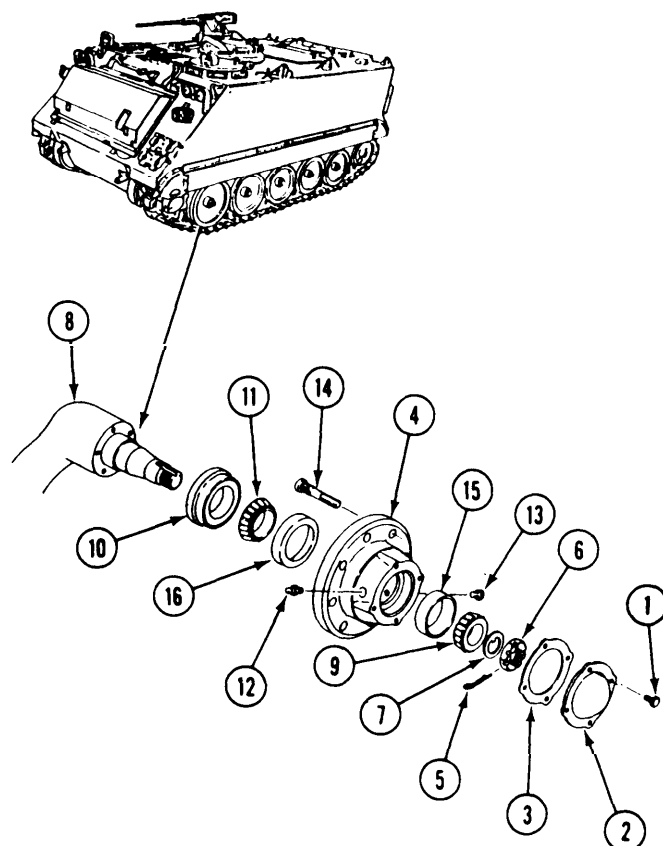

GO TO NEXT PAGE

CLEAN, INSPECT, AND REPLACE

- 7 .Check fittings and relief valve for wear and damage. Replace if needed.

Inspect bearings LAW TM 9-214. Replace if needed.

CAUTION

Bearings must be replaced as assemblies. Do not mix cups and bearings.

INSTALL

9. If removed, install new bearing cups (1 and 2) in hub (3). Use replacer.
10. If removed, install new bolts (4) in road wheel hub (3).
11. Apply a light coat of sealing compound to threads of relief valve (5) and lubrication fitting (6). Install valve and fitting in hub (3).

12. Pack inner bearing (7) with grease. Install bearing in rear of hub (3).
13. Apply a light coat of sealing compound to external surface of new seal (8).
14. Install new seal (8) in hub (3) using spacer.

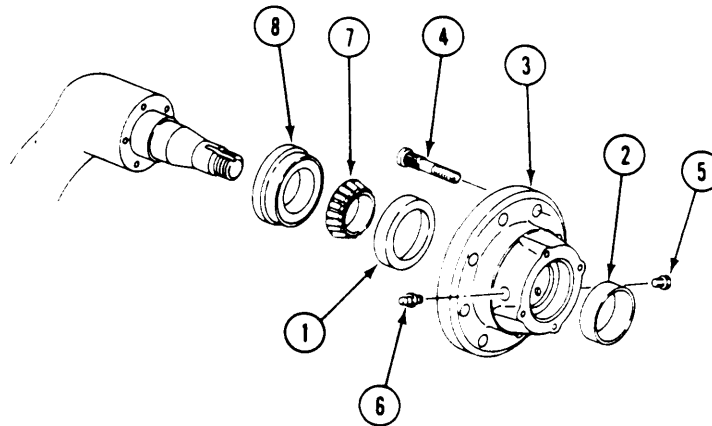
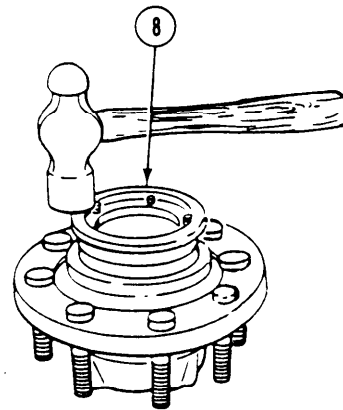
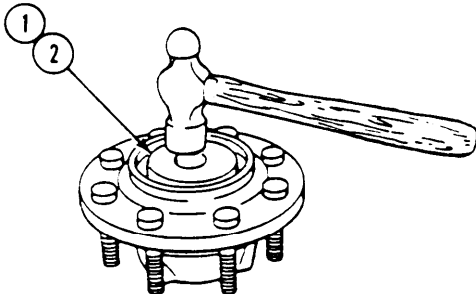

15. Place hub (1) on road wheel support arm (2). Completely pack cavity in hub with grease.
16. Pack outer bearing (3) with grease. Install in hub (1).
17. Install washer (4) and nut (5) on support arm (2). Tighten nut to adjust bearing as follows:
 - a. Tighten nut (5) to 140-150 lb-ft (190-203 N•m) torque. Use torque wrench.
 - b. Back off nut (5) until there is no torque.
 - c. Tighten nut (5) to 70-75 lb-ft (95-102 N•m) torque. Use torque wrench.
 - d. Back off nut to align nearest cotter pin hole in nut with cotter pin hole in support arm (2).
18. Install new cotter pin (6) in support arm (2).
19. Install new gasket (7), hub cap (8), and four screws (9) in hub (1).
20. Fill hub (1) with grease (see your LO).

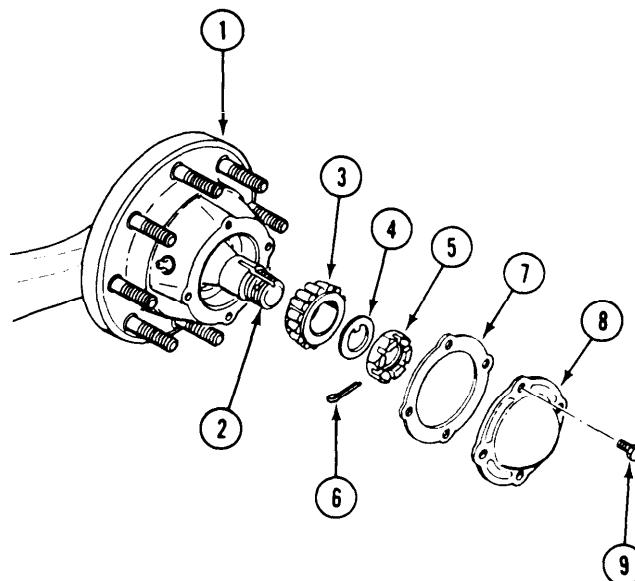

FOLLOW-THROUGH STEPS

1. Install road wheel (page 22-7).
 2. Install track shroud and covers (page 22-2).
 3. Road test carrier (page 2-45) to check that hub is installed properly.
 4. Check track tension (see your -10).
-

END OF TASK

REPLACE ROAD WHEEL SUPPORT ARM, BEARINGS, AND SEALS

DESCRIPTION

This task covers: Remove (page 22-12). Clean, Inspect, And Replace (page 22-13).
Install (page 22-13).

INITIAL SETUP

Tools:

General Mechanics Tool Kit (Item 30, App D)
Replacer (Item 56, App D)
Socket Wrench Set (Item 89, App D)
Torque Wrench (Item 95, App D)
Torque Wrench (Item 96, App D)

Materials/Parts:

Grease (Item 18, App C)
Sealing compound (Item 47, App C)
Bearing (2)
Inner seal
Outer seal
Packing
Retainer gasket
Key washer (3)

Personnel Required:

Unit Mechanic

References:

See your -10
See your -12

Equipment Conditions:

Carrier on level surface
Engine stopped/shutdown (see your -10)
Carrier blocked (see your -10)
Track shroud and covers removed (page 22-2)
Road wheel removed (page 22-7)
Road wheel hub removed (page 22-9)
Shock absorber removed from first, second, or fifth road wheel (page 22-26)
Torsion bar removed (page 22-32)

REMOVE

1. Remove six screws (1), road wheel arm assembly (2) (number one and two positions) and packing (3) (All except M741A1).
2. Remove two screws (1), four screws (4), road wheel support arm assembly (2), packing (3), and guard (5) from hull (number three position) (All except M741A1).

NOTE

Guard (5) used as support arm position three, is different from guard (6), used at support arm positions four and five. Do not interchange guards.

3. Remove two screws (1), four screws (4), road wheel support arm assembly (2), packing (3), and guard (5) from hull (number four and five positions) (All except M741A1). Discard packing.

4. Remove six screws (1) (number one position), five screws (number two, three, four, and five positions), road wheel support arm assembly, (2) and packing (3) from hull (M741A1 only).

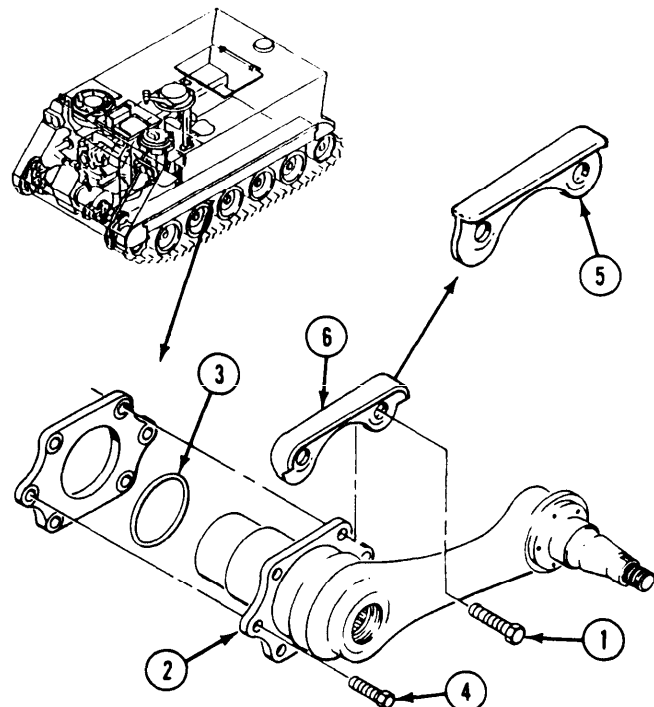

5. Remove six screws (1), three washers (2), seal (3), retainer (4), and gasket (5) from housing (6). Discard washers, seal and gasket.
6. Remove support arm (7), seal (8), and spacer (9) from housing (6). Discard seal.
7. If needed, remove two bearings (10) from housing (6).
8. Remove lubrication fitting (11) and relief valve (12) from support arm (7).

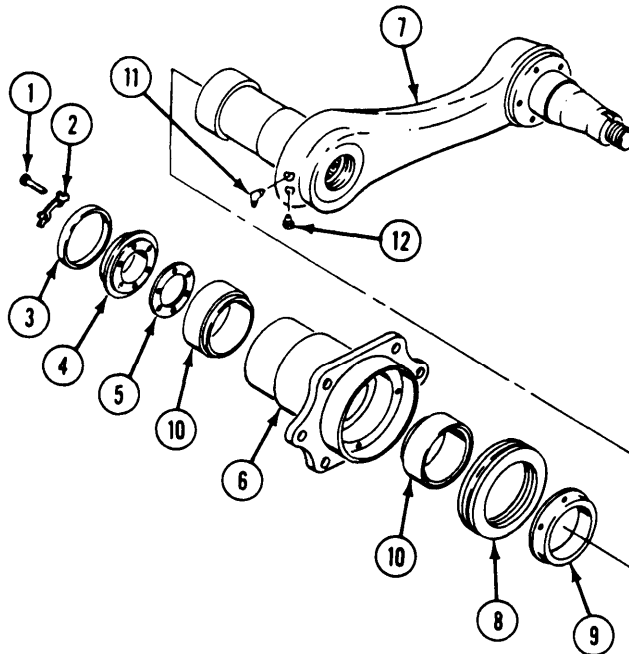

CLEAN, INSPECT, AND REPLACE

9. Check fittings and relief valve for wear and damage. Replace if needed.
10. Inspect bearings IAW TM 9-214. Replace if needed.

INSTALL

11. If removed, install two bearings (10) in housing (6) Use replacer.

NOTE

Make sure shoulders on bearings point toward center of housing.

12. Coat threads of relief valve (12) and lubrication fitting (11) with sealing compound. Install valve and fitting in support arm (7).
13. Put light coat of grease on bearing surface of support arm (7) and cork-rubber face of new seal (8). Place spacer (9) and seal, with pins facing housing, on shaft of support arm.
14. Install support arm (7) in housing (6). Align pins on seal (8) with holes in housing (6).
15. Put light coat of sealing compound on outer surface of new seal (3).
16. Install new gasket (5), retainer (4), and seal (3) in rear of housing (6). Use replacer. Secure with three new washers (2) and six screws (1). Do not tighten screws at this time.
17. Fill support arm housing (6) with grease until grease appears around retainer (4).
18. Tighten six screws (1) to 168–228 lb-in (19-26 N•m) torque. Use torque wrench (Item 95, App D) . Bend tabs on new washers (2).

19. Install new packing (1) on assembly (2).
20. Secure guard (3), packing (1), and assembled road wheel support arm assembly (4) to hull (number four and five positions) with four screws (5) and two screws (6). Tighten six screws to 130–140 lb-ft (176-190 N•m) torque. Use torque wrench (Item 96) (All except M741A1.)
21. Secure guard (7), packing (1) and assembled road wheel support arm assembly (4) to hull (number three position) with four screws (5) and two screws (6). Tighten six screws to 130-140 lb-ft (176–190 N•m) torque. Use torque wrench (Item 96) (All except M741A1.)
22. Secure assembled road wheel support arm (4) to hull (number one positions) with six screws (6). Tighten screws to 130-140 lb-ft (176-190 N•m) torque. Use torque wrench. (Item 96) All except M741A1.)
23. Secure assembled road wheel support arm (4) to hull (number two, three, four, and **five** positions) with five screws (5). Use six screws (number one position). Tighten screws to 130-140 lb-ft (176-190 N•m) torque. Use torque wrench (Item 96) (M741A1 only.)

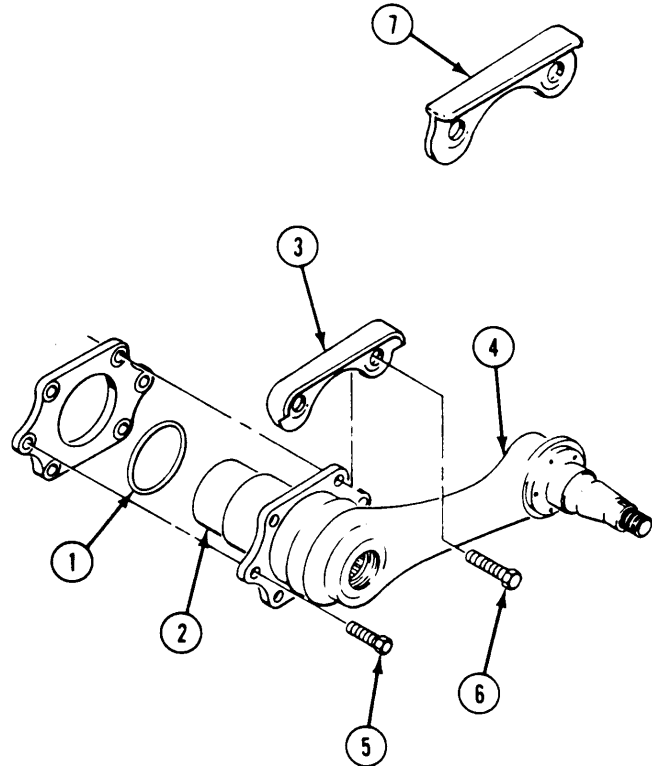

FOLLOW-THROUGH STEPS

- | | |
|---|---|
| <ol style="list-style-type: none"> 1. Install torsion bar (page 22-32). 2. If removed, install shock absorber (page 22-26). 3. Install road wheel hub (page 22-9). 4. Install road wheel (page 22-7). | <ol style="list-style-type: none"> 5. Lube road wheel supports (see your LO). 6. Install track shroud and covers (page 22-2). 7. Remove blocks used to keep carrier from moving (see your -10). 8. Road test carrier (page 2-91) to check that arm is installed properly. |
|---|---|

END OF TASK

REPLACE ROAD WHEEL SUPPORT ARM BUMPER STOP (M741A1 ONLY)

INITIAL SETUP**Tools:**

General Mechanics Tool Kit (Item 30, App D)

References:

See your - 10

Materials/Parts:

Self-locking nut (2)

Equipment Conditions:

Carrier on level surface

Carrier blocked (see your -10)

Engine stopped (see your -10)

Personnel Required:

Unit Mechanic

REMOVE

1. Reach between drive sprocket and first road wheel to locate bumper stop (1).
2. Remove two locknuts (2), washers (3) and bumper stop (1) from hull support. Discard locknuts.

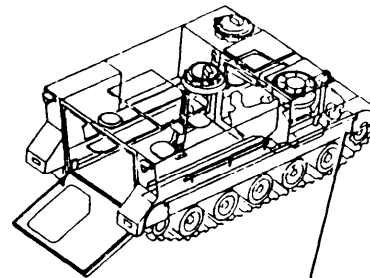
**INSTALL**

3. Place bumper stop (1) on hull support.
4. Secure bumper stop (1) with two washers (3) and new locknuts (2).

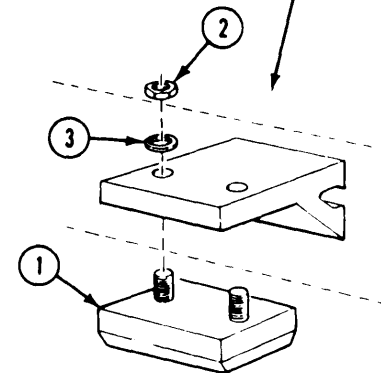

END OF TASK

REPLACE IDLER WHEEL

INITIAL SETUP

TOOLS:

General Mechanics Tool Kit (Item 30, App D)
Torque Wrench (Item 96, App D)

Materials/Parts:

Self-locking nut, per wheel (8)

Personnel Required:

Unit Mechanic

References:

See your -10

Equipment Conditions:

Carrier on level surface
Engine stopped/shutdown (see your -10)
Carrier blocked (see your -10)
Track shroud and covers removed (page 22-2)

REMOVE

1. Loosen idler wheel locknuts (1).
2. Disconnect track (see your -10).
3. Remove track from idler wheels (2).
4. Remove eight locknuts (1) and two idler wheels (2) from idler wheel hub (3). Discard locknuts.

NOTE

Inboard and outboard idler wheels are different ON ALL EXCEPT M741A1. Do not mix them up. Inboard wheel (marked 11669373) is 3-1/4 inches (83 mm) wide. Outboard wheel (marked 10907799) is 3-1/8 inches (79 mm) wide. Both M741A1 wheels (marked 10907799) are same width.

NOTE

Install inboard and outboard idler wheel in the right order. Make sure spokes do not line up.

6. Secure two wheels (2) to hub (3) with eight new locknuts (1). Tighten locknuts to 150-170 lb-ft (203-230 N•m) torque. Use torque wrench.
7. Install track over idler wheels.
8. Connect track and adjust tension (see your -10).

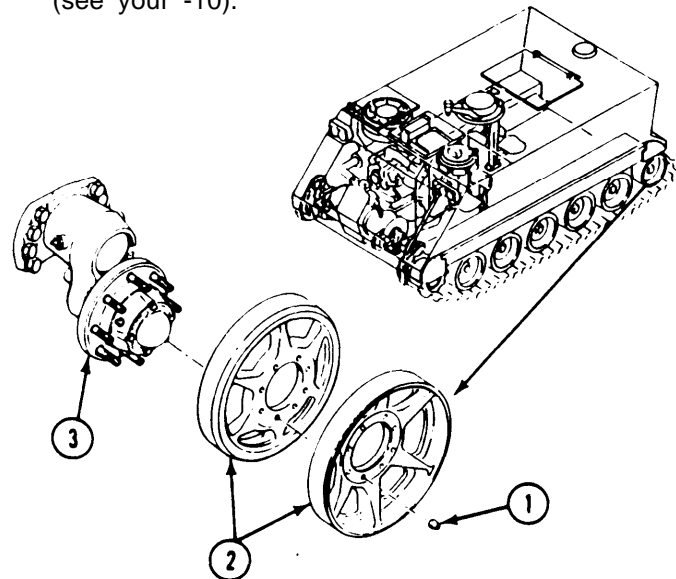

INSTALL

5. Place two idler wheels (2) on idler wheel hub (3).

FOLLOW-THROUGH STEPS

1. Install track shroud and covers (page 22-2).
2. Remove blocks used to keep earner from moving (see your -10).
3. Road test carrier (page 2-45) to check that idler wheel is installed properly.
4. Stop/shutdown engine (see your -10).

END OF TASK

REPLACE IDLER WHEEL ARM BEARINGS AND SEALS

DESCRIPTION

This task covers: Remove (page 22-17). Clean, Inspect. and Replace (page 22-18).
Install (page 22-18).

INITIAL SETUP**Tools:**

General Mechanics Tool Kit (Item 30, App D)
Replacer (Item 56, App D)
Spacer Ring (Item 70, App D)
Torque Wrench (Item 96, App D)

Materials/Parts:

Sealing compound (Item 46, App C)
Bolt, as needed
Cotter pin
Gasket
Key washer
Seal

Personnel Required:

Unit Mechanic

References:

see your -lo
See your LO
TM 9-214

Equipment Conditions:

Carrier on level surface
Engine stopped (see your -10)
Carrier blocked (see your -10)
Track shroud and covers removed (page 22-2)
Track disconnected (see your -10)
Idler wheel removed (page 22-16)

REMOVE

1. Remove four screws (1), hub cap (2), and gasket (3) from idler wheel hub (4). Discard gasket.
2. Remove cotter pin (5), nut (6), key washer (7), and hub (2) from idler wheel arm (8). Discard cotter pin.

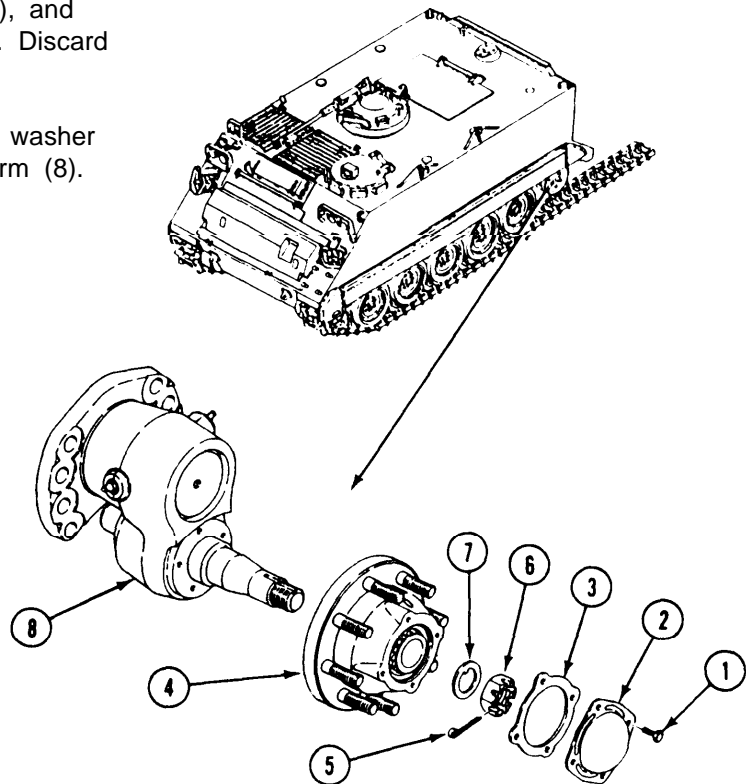

GO TO NEXT PAGE

3. Remove seal (1), inner bearing (2), and outer bearing (3) from hub (4). Discard seal.
4. Remove grease fitting (5) and relief valve (6) from hub (4).
5. If damaged, remove bolt(s) (7) from hub (4). Discard damaged bolt(s).
6. If damaged, remove bearing cups (8 and 9) from hub (4).

NOTE

Bearings and cups are replaced as a set.

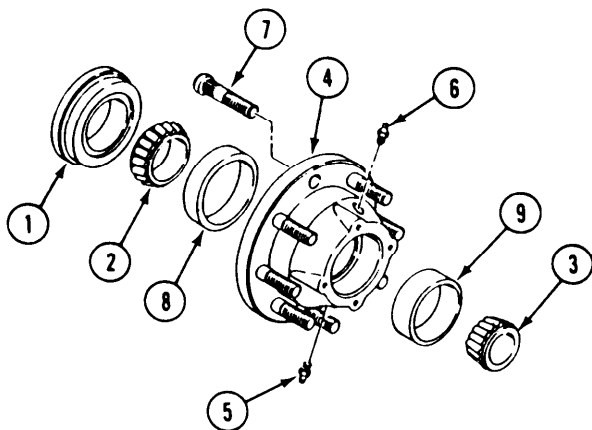

9. If removed, install new bolt(s) (13) in hub (12).
10. Apply light coat of sealing compound to threads of relief valve (14) and grease fitting (15). Install valve and fitting in hub (12).
11. Pack inner bearing (16) with grease. Install bearing in rear of hub (12).
12. Apply light coat of sealing compound to outer surface of new seal (17).

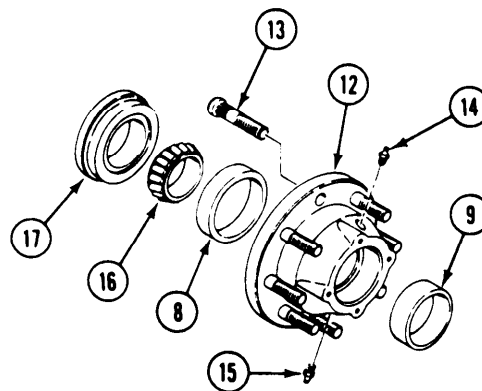

CLEAN, INSPECT, AND REPLACE

7. Clean and check bearings (TM 9-214). Replace bad bearings and cups.

INSTALL

8. If removed, install bearing cups (10 and 11) in hub (12). Use replacer.

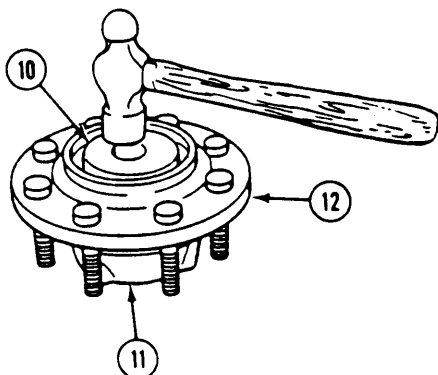

13. Install seal (17) in hub (12). Use spacer ring.

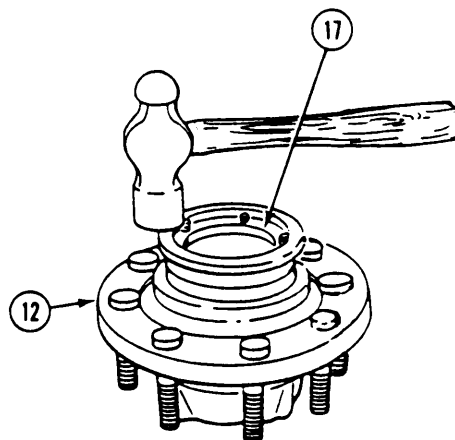

14. Place hub (1) on idler wheel arm (2). Completely pack cavity in hub with grease.
15. Pack outer bearing (3) with grease. Install bearing in hub (1).
16. Install keywasher (4) and nut (5) on arm (2). Tighten nut to adjust bearings as follows:
 - a. Tighten nut (5) to 140-150 lb-ft (190-203 N•m) torque. Use torque wrench.
 - b. Back off nut (5) until there is no torque.
 - c. Tighten nut (5) to 70-75 lb-ft (95-102 N•m) torque. Use torque wrench.
 - d. Back off nut (5) to align nearest cotter pin hole in nut with cotter pin hole in arm (2).
17. Install new cotter pin (6) in arm (7).
18. Install new gasket (8), hub cap (9), and four screws (10) in hub (1).
19. Fill hub (1) with grease (see your LO).

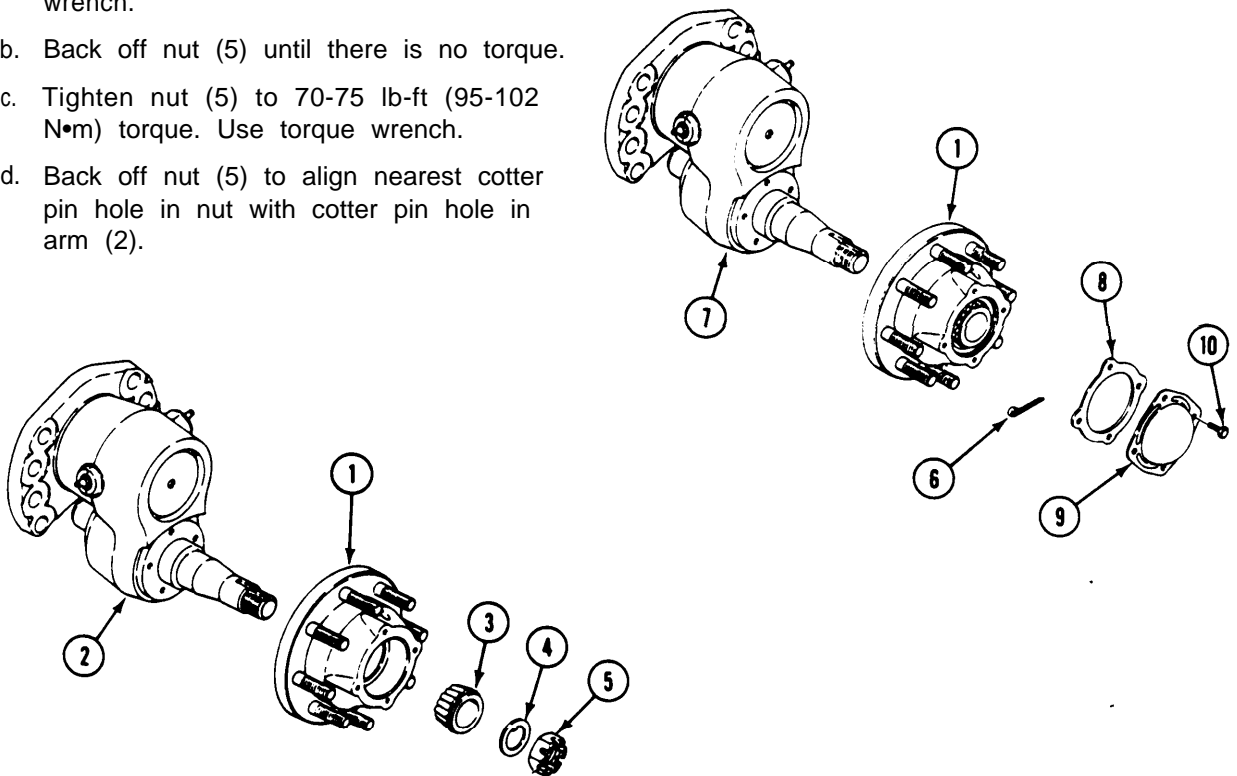

FOLLOW-THROUGH STEPS

1. Install idler wheel (page 22-16).
 2. Connect track and adjust tension (see your -10).
 3. Install track shroud and covers (page 22-2).
 4. Road test carrier (page 2-45) to check that idler wheel hub is installed properly.
-

END OF TASK

REPLACE IDLER WHEEL ARM ASSEMBLY (ALL EXCEPT M741A1)

DESCRIPTION

This task covers: Remove (page 22-20). Clean, Inspect, and Replace (page 22-21).
Install (page 22-21).

INITIAL SETUP

Tools:

General Mechanics Tool Kit (Item 30, App D)
Torque Wrench (Item 96, App D)

References:

see your -10
See your LO

Materials/Parts:

Grease (Item 18, App C)
Sealing compound (Item 54, App C)
Preformed packing
Seal

Equipment Conditions:

Carrier on level surface
Engine stopped/shutdown (see your -10)
Carrier blocked (see your -10)
Track shroud and covers removed (page 22-2)
Track disconnected (see your -10)
Idler wheel removed (page 22-16)
Road wheel hub removed (page 22-9)
Track tension adjuster disconnected from idler wheel arm (page 22-24)

Personnel Required:

Unit Mechanic
Helper (H)

REMOVE

1. Remove eight screws (1) and idler wheel assembly (2) from hull.
2. Remove retaining ring (3) and access cover (4) from idler wheel assembly (2).
3. Remove preformed packing (5), retaining ring (6), and spacer (7) from idler wheel assembly (2). Discard preformed packing.

4. Remove idler arm (8) and seal (9) from idler wheel assembly (2). Discard seal.
5. Remove safety relief valve (10) and fitting (11) from idler arm (8).

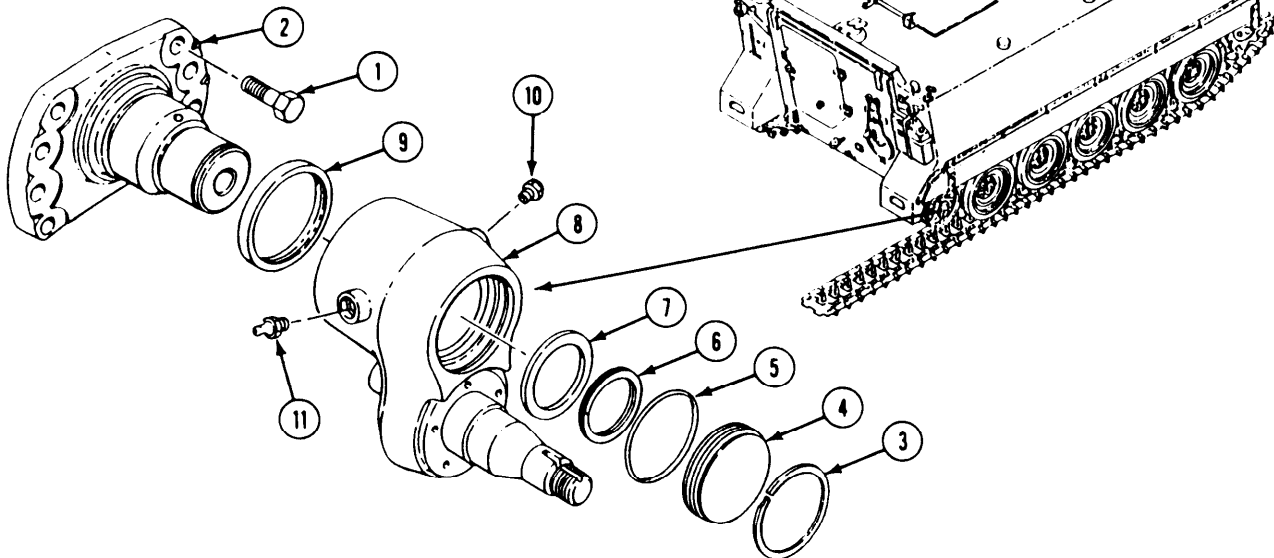

CLEAN, INSPECT, AND REPLACE

6. Check fittings and safety relief valve for wear and damage. Replace if needed.
7. Clean and check retaining rings and spacer for damage. Replace if needed.

INSTALL

8. Apply light coat of sealing compound on threads of safety relief valve (1) and fitting (2) .

NOTE

Install fitting on the forward side of idler arm (see your LO).

9. Install safety relief valve (1) and fitting (2) in idler arm (3).

10. Install new seal (4) and idler arm (3) on idler wheel assembly (5).
11. Install spacer (6), retaining ring (7), and new preformed packing (8) in idler arm (3).
12. Install access cover (9) and retaining ring (10) in idler arm (3).
13. Place track tension adjuster on shaft (11) at rear of idler arm (3). Align idler wheel assembly (5) with holes on hull. Secure with eight screws (12). Tighten screws to 315-325 lb-ft (427-441 N·m) torque. Use torque wrench.
14. Fill idler arm (3) with grease (see your LO).

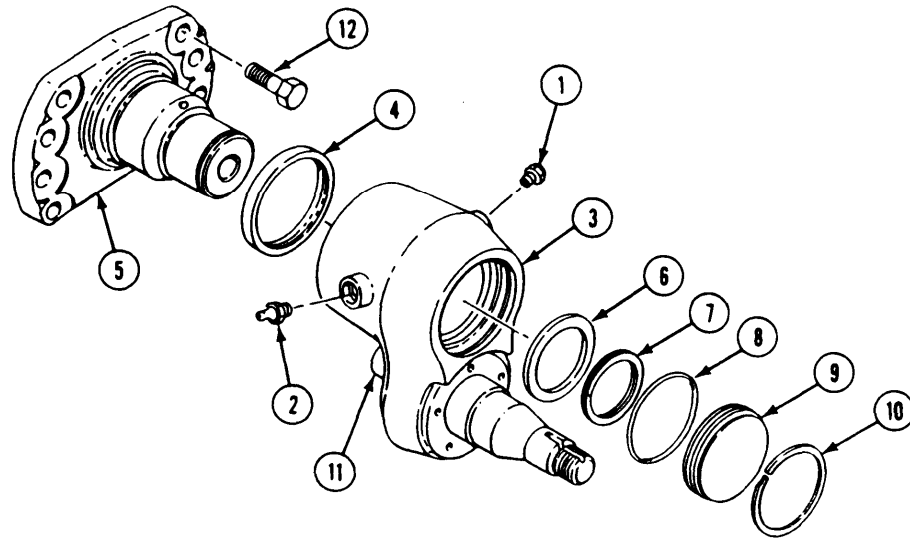

FOLLOW-THROUGH STEPS

1. Connect track tension adjuster to idler arm (page 22-24).
2. Install road wheel hub (page 22-9).
3. Install idler wheel (page 22-16).
4. Connect track and adjust tension (See your -10),
5. Install track shroud and covers (page 22-2).
6. Road test carrier (page 2-45) to check that idler wheel arm is installed properly.
7. Stop/shutdown engine (see your -10).

END OF TASK

REPLACE IDLER WHEEL ARM (M741A1 ONLY)

DESCRIPTION

This task covers: Remove (page 22-22). Clean, Inspect, and Replace (page 22-23).
Install (page 22-23).

INITIAL SETUP

Tools:

General Mechanics Tool Kit (Item 30, App D)
Socket Wrench Set (Item 90, App D)
Torque Wrench (Item 98, App D)

References:

see your -lo
See your -13
See your LO

Materials/Parts:

Grease (Item 18, App C)
Sealing compound (Item 47, App C)
Inner packing
Outer packing

Equipment Conditions:

Carrier on level surface
Carrier blocked (see your -10)
Engine stopped (see your -10)
Track shroud and covers removed (page 22-2)
Track disconnected (see your -10)
Idler wheel removed (page 22-16)
Road wheel hub removed (page 22-9)
Track tension adjuster disconnected from idler wheel arm (page 22-24)

Personnel Required:

Unit Mechanic
Helper

REMOVE

1. Remove three screws (1), retainer (2), and idler arm (3) from spindle (4).
2. Remove outer packing (5) and inner packing (6) from idler arm (3). Discard packing.

3. Remove grease fitting (7) and relief valve (8) from idler arm (3).
4. Remove eight screws (9) and spindle (4).

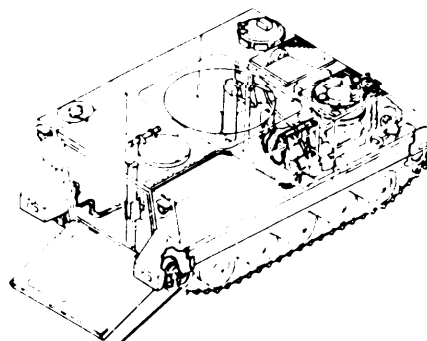
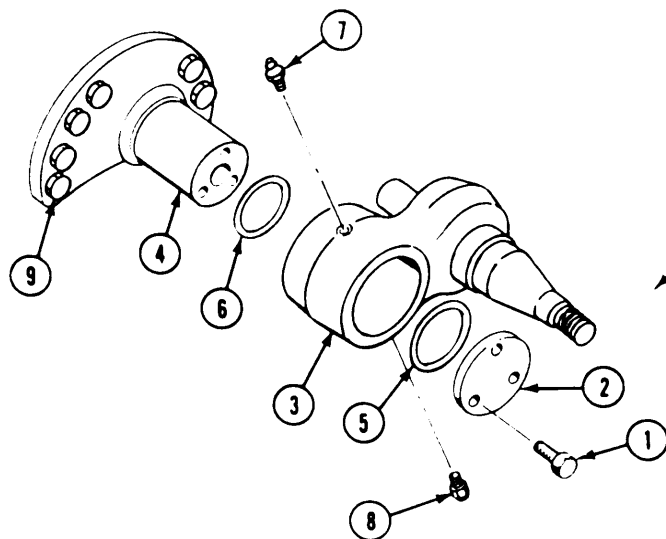

CLEAN, INSPECT, AND REPLACE

5. Check fittings and relief valve for wear and damage. Replace if needed,
6. Clean and check bearings (TM 9-214). Replace bad bearings and cups.

INSTALL

7. Place spindle (1) on hull. Secure with eight screws (2). Tighten screws to 315-325 lb-ft (427-441 N-m) torque. Use torque wrench.
8. Apply light coat of sealing compound to threads of relief valve (3) and grease fitting (4). Install valve and fitting in idler arm (5) with fitting (4) facing forward.
9. Apply continuous coat of grease on shaft of spindle (1) and bearing surface inside arm (5).
10. Install new inner packing (6) and new outer packing (7) in arm (5).
11. Place track tension adjuster (page 22-24) on shaft at rear of arm (5). Install arm on spindle (1).
12. Install retainer (9) on spindle (1) with cutout portion at bottom of groove in arm. Secure with three screws (8). Tighten screws to 75–80 lb-ft (102–108 N-m) torque. Use torque wrench.
13. Fill idler arm with grease (see your LO).

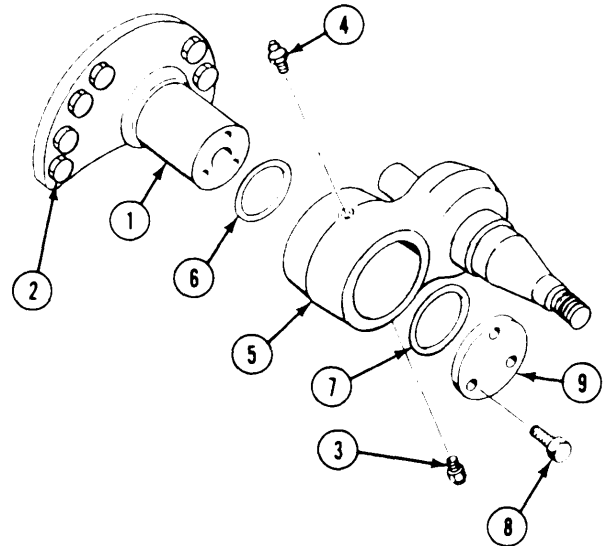

FOLLOW-THROUGH STEPS

1. Connect track tension adjuster to idler arm (page 22-24).
2. Install road wheel hub (page 22-9).
3. Install idler wheel (page 22-16).
4. Connect track and adjust tension (see your –10).
5. Install track shroud and covers (page 22–2).
6. Road test earner (page 2-45) to check that idler wheel arm is installed properly.
7. Stop engine (see your –10).

END OF TASK

REPLACE TRACK TENSION ADJUSTER AND MOUNT.

DESCRIPTION

This task covers: Remove (page 22-24). Clean, Inspect, and Replace (page 22-24).
Install (page 22-25).

INITIAL SETUP

Tools:

General Mechanics Tool Kit (Item 30, App D)
Torque Wrench Adapter (Item 8, App D)
Torque Wrench (Item 96, App D)

Personnel Required:

Unit Mechanic

References

See your -10

Equipment conditions

Carrier on level surface
Engine stopped/shutdown (see your -10)
Carrier blocked (see your -10)
Track shroud and covers removed (page 22-2)
Track disconnected (see your -10)

REMOVE

1. Remove screw (1) end washer (2) from mount (3).
2. Remove screw (4) and washer (5) from shaft on idler arm.
3. Remove two screws (6) from mount (3). Loosen screw (7). Rotate mount and remove screw (7).
4. Pull track adjuster (8) down. Remove mount (3) from adjuster.
5. Remove adjuster (8) from shaft on idler arm.
6. Remove grease fitting (9) and relief valve (10) from adjuster (8).

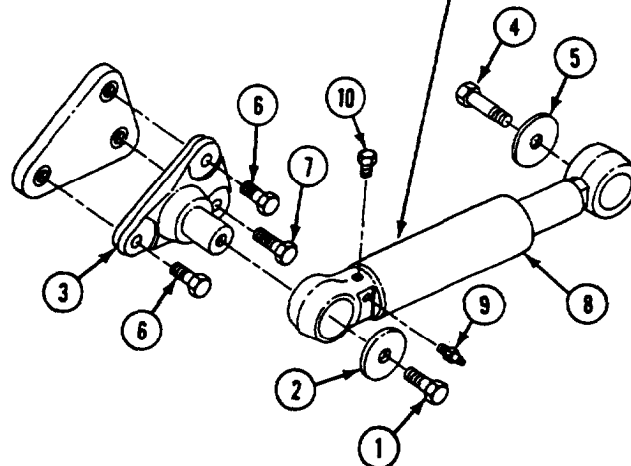
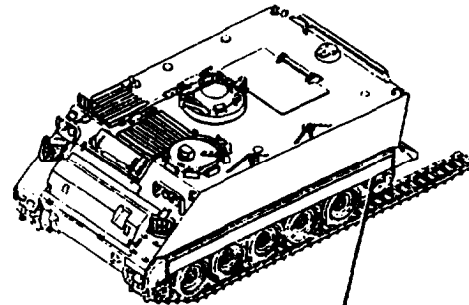

CLEAN, INSPECT, AND REPLACE

7. Check fittings end relief valve for wear and damage. Replace if needed.

INSTALL

8. Install relief valve (1) and grease fitting (2) in track tension adjuster (3).

NOTE

Grease fitting and relief valve of track tension adjuster should be toward front of earner. Make sure grease fitting is pointing out.

9. Place track adjuster (3) on shaft of idler arm.
10. Install mount (4) in front of adjuster (3). Raise adjuster and mount. Align hole in mount with hole in hull for screw (5).
11. Install screw (5) in mount (4). Tighten until snug.

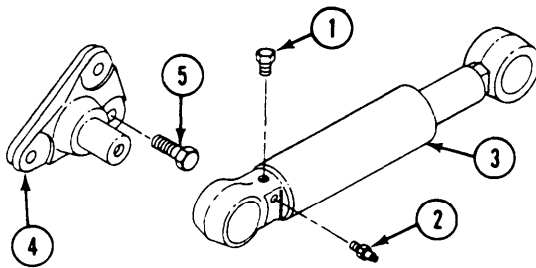

12. Rotate mount (4). Install two screws (6).

NOTE

When using torque wrench with torque wrench adapter, torque value must be corrected. Procedure for converting torque value is on page 2-30.

13. Tighten screw (5) and two screws (6) to 130-140 lb-ft (176-190 N-m) torque. Use torque wrench and adapter.
14. Install washer (7) and screw (8) in shaft idler arm. Tighten screw to 130-140 lb-ft (176-190 N-m) torque. Use torque wrench.
15. Install washer (9) and screw (10) on mount (4). Tighten screw to 130-140 lb-ft (176-190 N-m) torque. Use torque wrench.

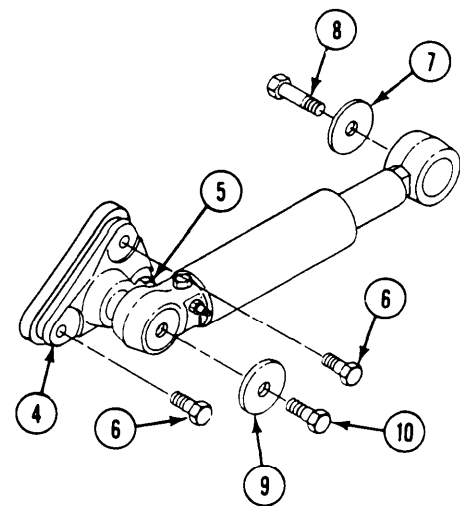
**FOLLOW-THROUGH STEPS**

1. Connect and adjust track (see your -10).
2. Install track shroud and covers (page 22-2).
3. Road test earner (page 2-45) to check that adjuster is installed properly.

END OF TASK

REPLACE SHOCK ABSORBER

DESCRIPTION

This task covers: Remove (page 22-26). Install (page 22-27).

INITIAL SETUP

Tools:

General Mechanics Tool Kit (Item 30, App D)
 Shock Remover (Item 53, App D)
 Torque Wrench (Item 97, App D)

References:

See your -10

Equipment Conditions:

Engine stopped/shutdown (see your -10)
 Carrier blocked (see your -10)
 Track shroud and covers removed (page 22-2)
 Remove road wheel for respective shock absorber (page 22-7)

Materials/Parts:

Cotter pin (2)
 Inner seal (2)
 Outer seal (2)

Personnel Required:

Unit Mechanic

REMOVE

1. Remove two cotter pins (1) and nuts (2) securing shock absorber (3) to hull mount and road arm. Discard cotter pins.
2. Remove two shoulder washers (4) and outer seals (6) from both ends of shock absorber (3). Discard outer seals.

NOTE

M741A1 does not have Items (1), (4) and (5) at top of shock absorber. Remove washer (6) and bearing (7) from shock absorber (3).

3. Position remover on hull mounting bracket (8). Hit remover with heavy hammer to loosen upper end of shock absorber (3). Remove remover. Remove shock absorber and inner seal (9) from hull mounting bracket. Discard seal.
4. Position remover on support arm pin (10). Hit remover with heavy hammer to loosen lower end of shock absorber (3). Remove shock absorber and inner seal (9) from support arm pin. Discard seal.

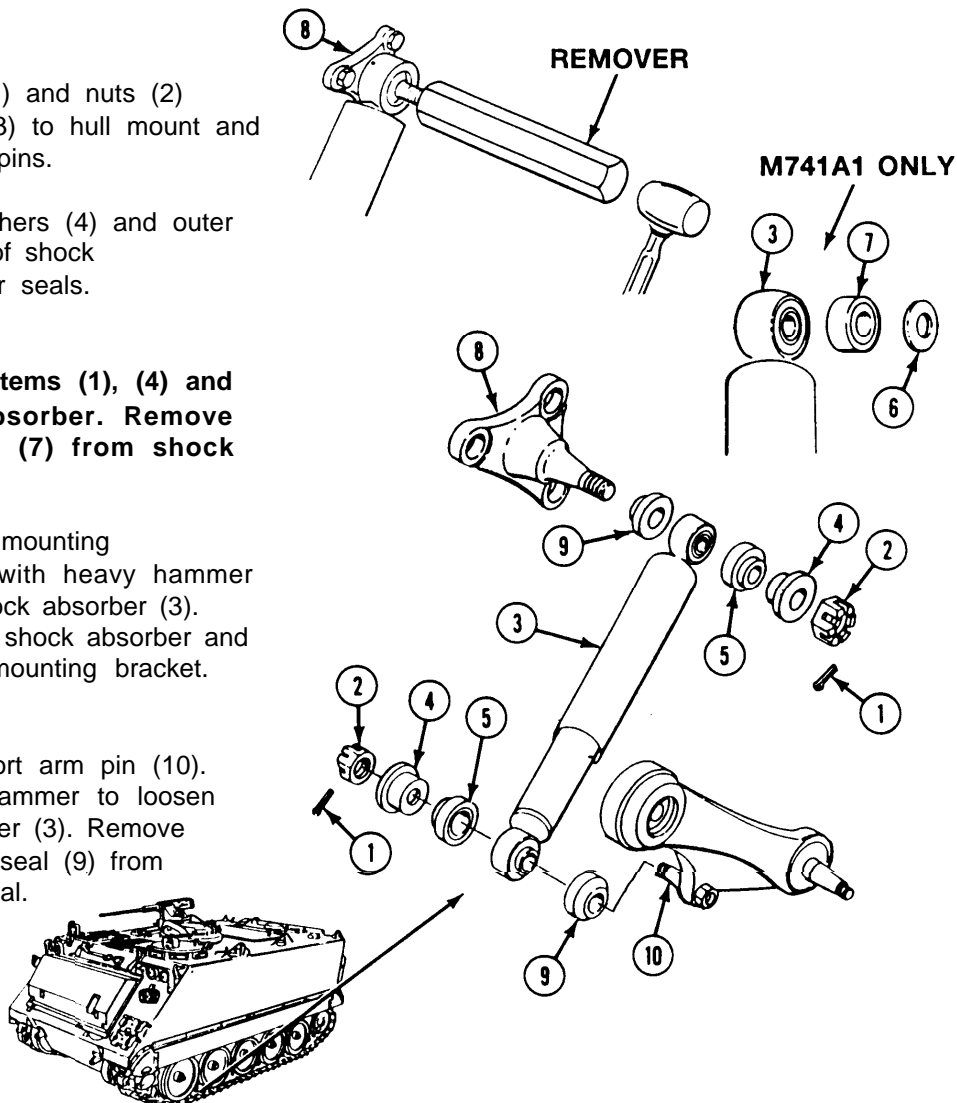

INSTALL

5. Install new inner seal (1) on support arm pin (2).

NOTE

Exercise new shock absorber to the fully extended position and move shock absorber back and forth several times until resistance can be felt throughout the entire length of the stroke.

Make sure shock absorber is installed with large end of bearing installed first.

6. Install shock absorber (3), new outer seal (4), and shoulder washer (5) on support arm pin (2).
7. Install new inner seal (1), shock absorber (3), new outer seal (4), and shoulder washer (5) on hull bracket (6).

NOTE

M741A1 does not have items (1), (4), and (5) at top of shock absorber. Install shock absorber (3), bearing (7), and washer (8) on hull bracket (6).

8. Secure shock absorber (3) with two nuts (9).
9. Tighten two nuts (9) to 60-80 lb-ft (8-11 N·m) torque. Use torque wrench. Secure with new cotter pins (10).

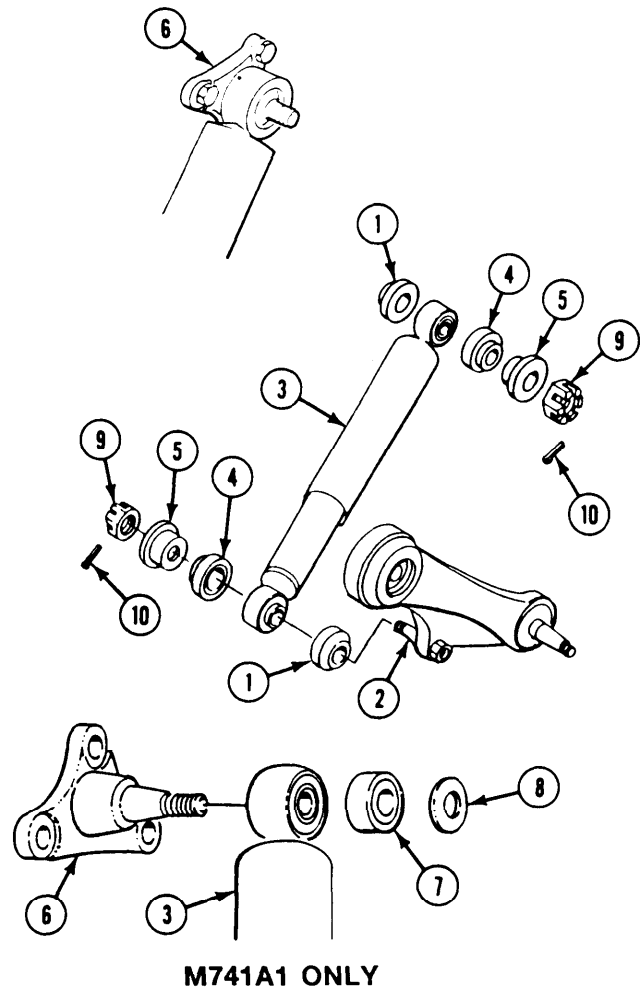

FOLLOW-THROUGH STEPS

1. Install road wheel (page 22-7).
2. Install track shroud and covers (page 22-2).
3. Road test carrier (page 2-91) to check that shock absorber is installed properly.

END OF TASK

REPLACE SHOCK ABSORBER PIN

INITIAL SETUP

Tools:

General Mechanics Tool Kit (Item 30, App D)
Socket Wrench Set (Item 90, App D)
Torque Wrench (Item 98, App D)

Materials/Parts:

Self-locking nut
Wood blocks

Personnel Required:

Unit Mechanic

References:

See your -10

Equipment Conditions:

Carrier on level surface
Engine stopped/shutdown (see your -10)
Carrier blocked (see your -10)
Track shroud and covers removed (page 22-2)
Respective road wheel removed (page 22-7)
Respective road wheel support arm removed
(page 22-12)

REMOVE

1. Remove locknut (1) from pin (2). Discard locknut.
2. Place road wheel support arm (3) on wood blocks. Drive out pin (2) with a wood block and hammer.

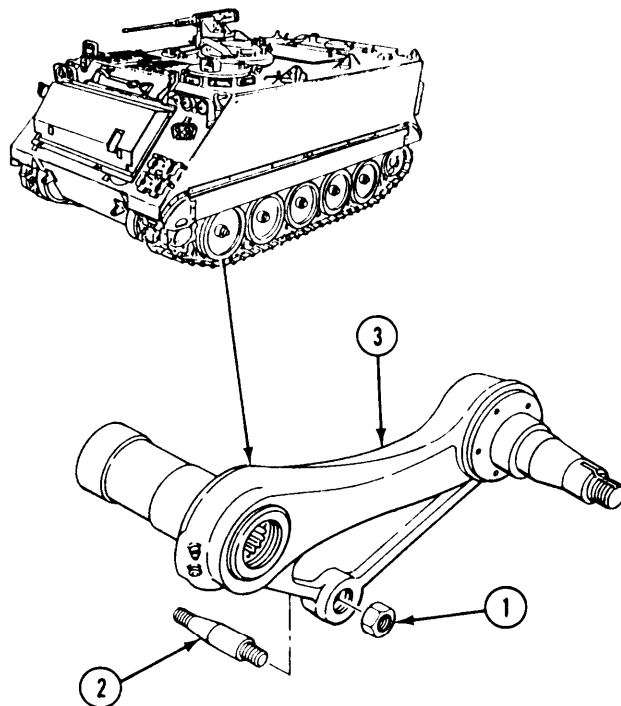

INSTALL

3. Install pin (2) in road wheel support arm (3). Secure with new locknut (1). Tighten locknut to 210–230 lb ft (283-310 N-m). Use torque wrench.

FOLLOW-THROUGH STEPS

1. Install road wheel support arm (page 22-12).
 2. Install road wheel (page 22-7).
 3. Install track shroud and covers (page 22-2).
 4. Road test earner (page 2-45) to check that shock absorber pin is installed properly.
-

END OF TASK

REPLACE SHOCK ABSORBER MOUNT

INITIAL SETUP

Tools:

General Mechanics Tool Kit (Item 30, App D)
Torque Wrench (Item 96, App D)

Personnel Required:

Unit Mechanic

References:

See your -10

Equipment Conditions:

Carrier on level surface
Engine stopped/shutdown (see your -10)
Carrier blocked (see your -10)
Track shroud and covers removed (page 22-2)
Respective road wheel removed (page 22-7)
Respective shock absorber removed
(page 22-26)

REMOVE

1. Remove three screws (1) from shock absorber mount (2).
2. Remove mount (2) from hull.

INSTALL

3. Place mount (2) on hull.
4. Install three screws (1). Tighten screws to 130-140 lb-ft (176-190 N·m) torque. Use torque wrench.

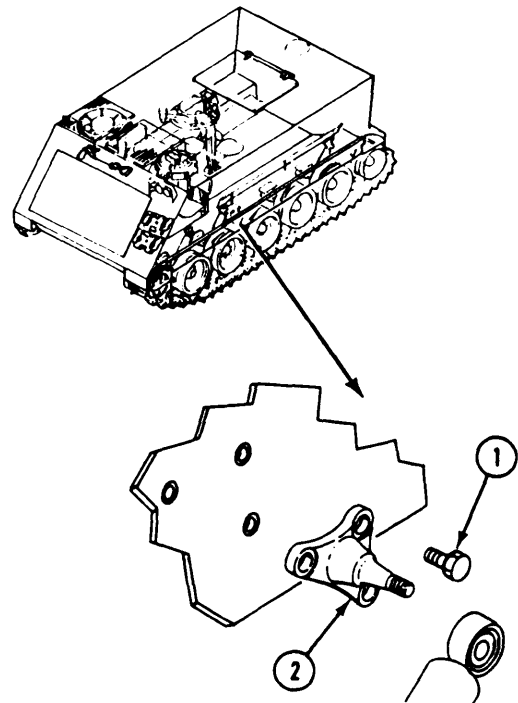

FOLLOW-THROUGH STEPS

1. Install shock absorber (page 22-26).
2. Install road wheel (page 22-7).
3. Install track shroud and covers (page 22-2).

END OF TASK

REPLACE DRIVE SPROCKETS, CUSHIONS, AND CARRIER ASSY

DESCRIPTION

This task covers: Remove (page 2230). Clean, Inspect, and Replace (page 22-31).
Install (page 22-31).

INITIAL SETUP

Tools:

- General Mechanics Tool Kit (Item 30, App D)
- Socket Wrench Set (Item 90, App D)
- Torque Wrench (Item 98, App D)

Materials/Parts:

- Self-locking bolts (20)
- Self-locking bolts (10)

Personnel Required:

Unit Mechanic

References:

See your -10

Equipment Conditions:

- Carrier on level surface
- Engine stopped/shutdown (see your -10)
- Carrier blocked (see your -10)
- Track shroud and covers removed (page 22-2)
- Track disconnected (see your -10)

REMOVE

NOTE

The following maintenance procedure applies to one sprocket carrier assembly only.

You will have one or two sprocket wheel carrier configurations. The oldest configuration uses a shorter bolt. Refer to TM 9-2350-261-24P for proper replacement part numbers.

1. Remove track (1) from drive sprocket carrier (2).

- 1.1 Remove ten lockbolts (2.1) and drive sprocket carrier (2) from vehicle. Discard lock bolts.
2. Remove twenty lock bolts (3) and two sprockets (4) from sprocket wheel carrier (5). Discard lock bolts.
3. Remove two rubber cushions (6) from sprocket wheel carrier (5).
4. If needed, repeat steps (1), (2), and (3) for other drive sprocket carrier assemblies.

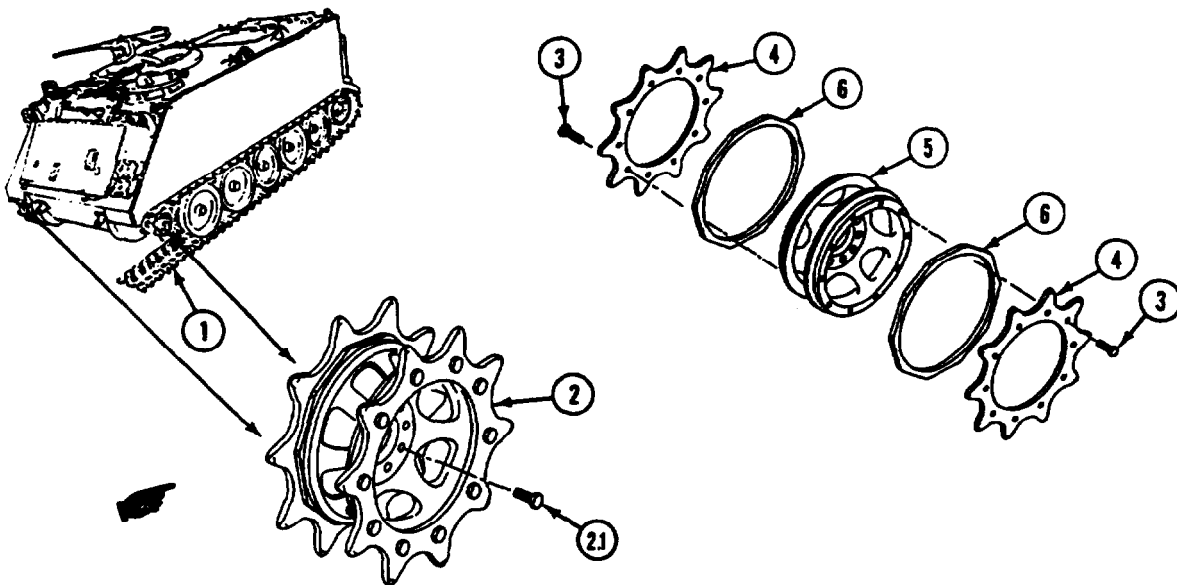

CLEAN, INSPECT, AND REPLACE

5. Check cushions and sprockets for wear and damage. Replace if needed.

INSTALL

6. Place two cushions (1) on sprocket wheel carrier (2). Center short flat areas between mounting holes in sprocket wheel carrier assembly rim. Press an cushion until firmly seated against flange of sprocket wheel carrier assembly.
7. Place two sprockets (3) on sprocket wheel carrier (2). Secure with twenty new lock bolts (4). Tighten lock bolts to 110-115 lb-ft (149-156 N-m) torque. Use torque wrench.
- 7.1 Install drive sprocket carrier (5) on vehicle. Secure with ten new lock bolts (6). Tighten lock bolts to 170-195 lb-ft. (231-264 N-m) torque User torque wrench.
8. Mark sprockets (3) and cushions (1) for rotation check after road test.
9. Place track (7) on drive sprocket carrier (5).

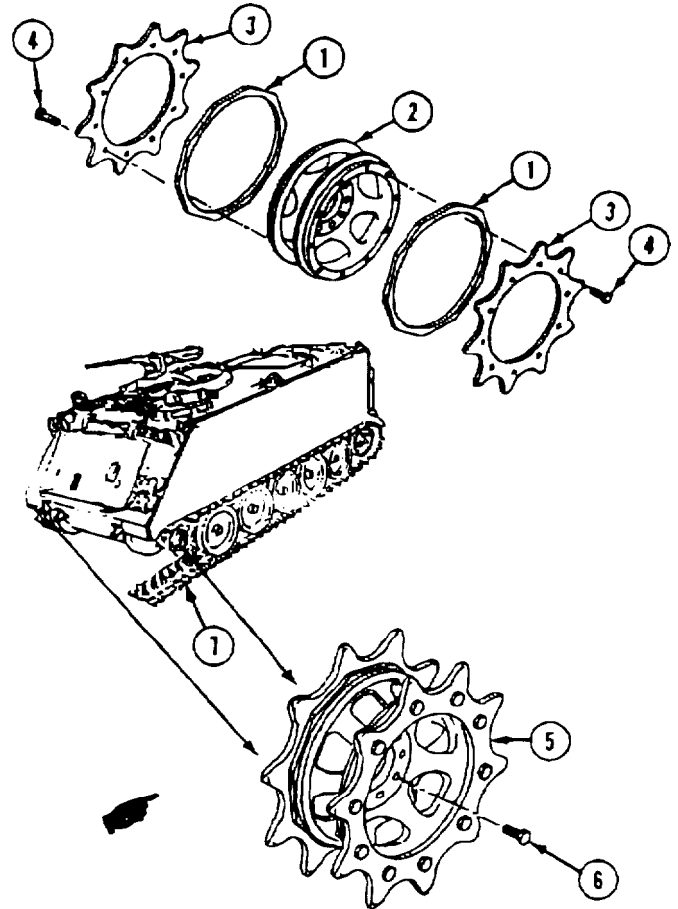

FOLLOW-THROUGH STEPS

1. Connect track and adjust tension (see your -10).
2. Install track shroud and covers (page 22-2).
3. Road test carrier (page 2-101) to check that drive sprocket and carrier assembly are installed properly.
4. After road test, check rotation of cushion with respect to sprockets. Measure from the outer edge of the cushion. Replace cushion that rotates beyond 1 1/2 inches (4 cm) of initial position.

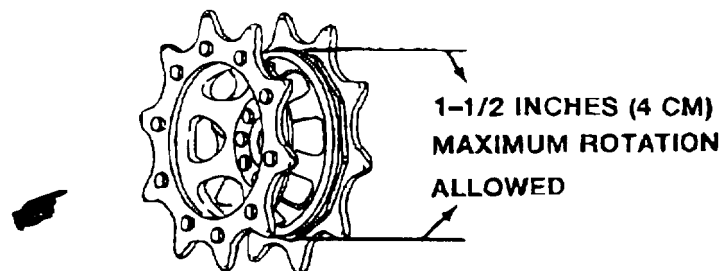

END OF TASK

REPLACE TORSION BAR

DESCRIPTION

This task covers: Remove (page 22-32). Install (page 22-34).

INITIAL SETUP

Tools:

General Mechanics Tool Kit (Item 30, App D)
 Adapter (Item 10, App D)
 Road Wheel Lifter (Item 39, App D)
 Puller (Item 48, App D)
 Socket Head Cap Screw (Item 62, App D)
 Plug Wrench (Item 92, App D)
 Torque Wrench (Item 96, App D)

Materials/Parts:

Grease (Item 18, App C)

Personnel Required:

Unit Mechanic
 Helper (H)

References:

See your -10
 See your LO

Equipment Conditions:

Engine stopped/shutdown (see your -10)
 Carrier on level surface
 Carrier blocked (see your -10)
 Track shroud and covers removed (page 22-2)
 Road wheel removed (page 22-7)
 Shock absorber removed from second or fifth road wheel (page 22-26)
 Remove power plant for first torsion bar, right side only (page 5-11)
 Driver's front floor plate removed (page 24-44) for first torsion bar, left side only
 Power plant rear access panel removed (see your -10) for second torsion bar, right side only
 Driver's rear floor plate removed (page 24-44) for second torsion bar, left side only
 Floor plates removed (page 24-37) for third and fourth torsion bar
 Mortar turntable tread plates open (M106A2 and M125A2 only) for fifth torsion bar (see your -10)

REMOVE

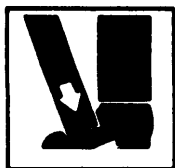

WARNING
 If road wheel lifter slips while lowering road arm, it could injure you. Stand clear before you lower road arm.

1. With road wheel removed and road arm raised on lifter, start engine (see your -10). Place range selector in 1. Slowly drive earner forward off lifter so that road wheel support arm (1) hangs freely.
2. Remove screw (2) from plug (3).

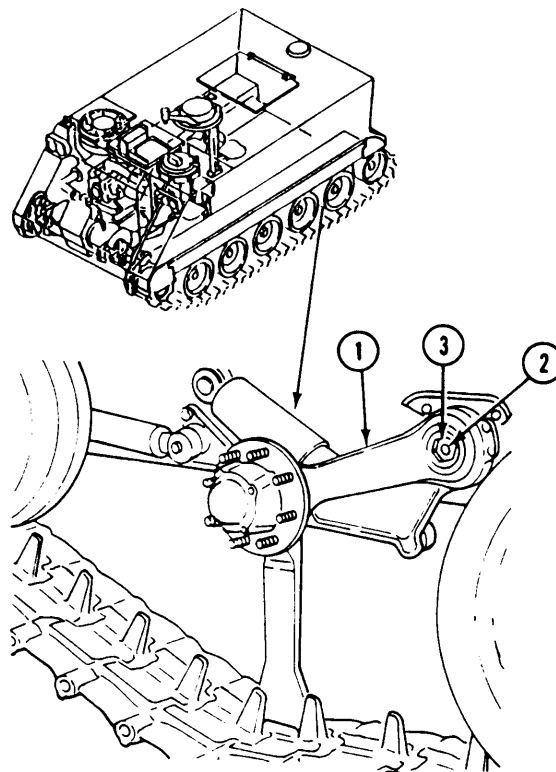

3. Remove plug (1) from road wheel support arm (2). Use plug wrench.

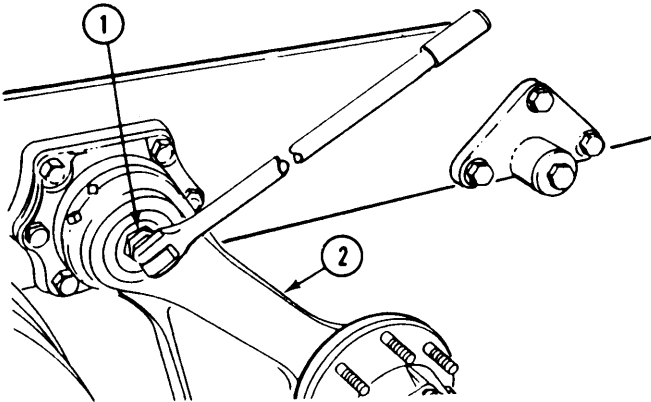

NOTE

Special socket head cap screw is used with adapter.

4. Thread special screw through adapter.

NOTE

Screw is installed with head inside adapter.

5. Thread adapter on puller, then thread adapter with screw into torsion bar.

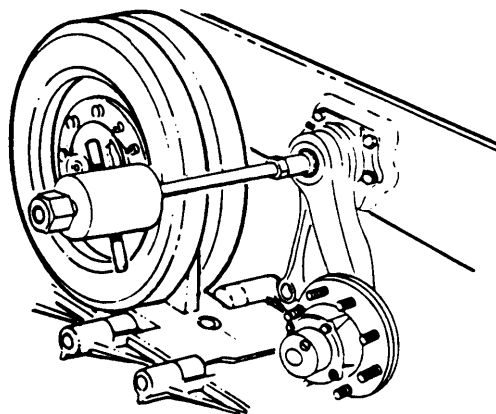

CAUTION

When removing or installing torsion bars, the index or missing tooth on the anchor end of torsion bar must align with index on spline in road wheel arm, to allow bar to pass through (page 22-34).

6. Pull torsion bar (3) from torsion bar anchor (4). Use slide hammer on puller.
7. Remove puller and adapter from torsion bar.
8. If torsion bar (3) is broken, remove as follows:
 - a. Remove road wheel end of torsion bar in the same way as unbroken torsion bar.
 - b. Pull or drive end of broken bar from its splined seat in torsion bar anchor (4).

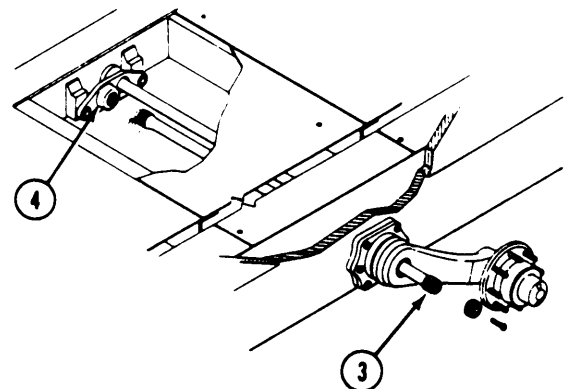

GO TO NEXT PAGE

INSTALL

CAUTION

When removing or installing torsion bars, the index or missing tooth on the anchor end of torsion bar must align with index on spline in road wheel arm, to allow bar to pass through.

Align index or missing tooth on end of torsion bar with index on road wheel arm and torsion bar anchor before installing.

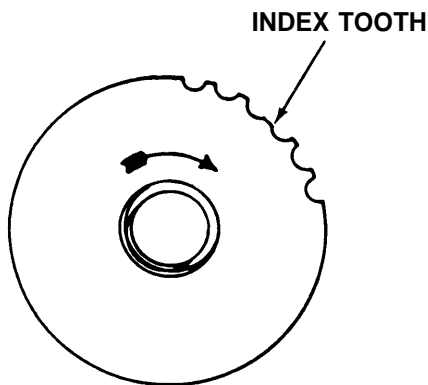

CAUTION

Handle torsion bar with care. Do not tear or cut wrapping.

NOTE

Left and right torsion bars are not interchangeable. To determine correct bar, place arrow on end of torsion bar outboard, with arrow at top. Arrow must point toward front of earner.

9. Thread puller with adapter and screw into torsion bar.
10. Install torsion bar (1) through road wheel arm (2) and anchor (3). (H) Guide torsion bar into anchor to ensure proper alignment. Use slide hammer on puller to seat torsion bar.
11. Remove puller and adapter from torsion bar.
12. Put a light coat of grease on threads of plug (4) (see your LO). Install plug in road wheel arm (2).
13. Tighten plug (4) to 50-75 lb-ft (68-102 N·m) torque. Use torque wrench and plug wrench.
14. Install screw (5) in plug (4).

NOTE

You may need to jack carrier, to raise road arm, before positioning road wheel lifter.

15. Position road wheel lifter (page 22-7).

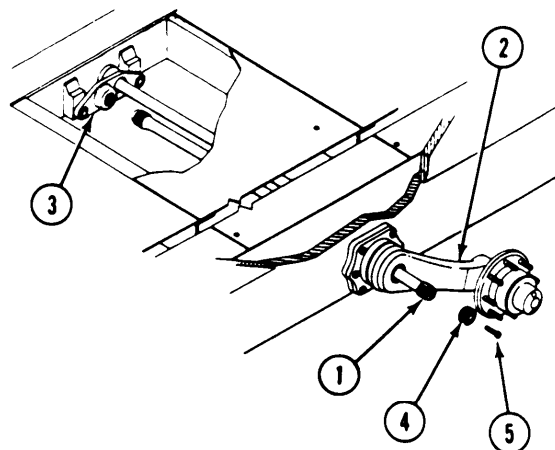

FOLLOW-THROUGH STEPS

1. Install floor plates (page 24–37) for third and fourth torsion bars.
2. Install driver's rear floor plate (page 24-44) for second torsion bar, left side only.
3. Install power plant rear access panel (see your -10) for second torsion bar, right side only.
4. Install driver's front floor plate (page 24-44) for first torsion bar, left side only.
5. Install power plant (page 5-11) for first torsion bar, right side only.
6. If removed, install shock absorber (page 22-26).
7. Install road wheel (page 22–7).
8. Install track shroud and covers (page 22-2).
9. Remove blocks used to keep carrier from moving (see your –10).
10. Road test earner (page 2-45) to check that torsion bar is installed properly.
11. Stop/shutdown engine (see your -10).

END OF TASK

REPLACE TORSION BAR ANCHOR

DESCRIPTION

This task covers: Remove (page 22-36). Clean, Inspect, and Replace (page 22-37).
Install (page 22-37).

INITIAL SETUP

Tools:

General Mechanics Tool Kit (Item 30, App D)
Socket wrench Set (Item 90, App D)
Torque wrench (Item 98, App D)

Materials/Parts:

Cotter pin (2)
Preformed packing

Personnel Required:

Unit Mechanic

References:

See your -10

Equipment Conditions:

Carrier on level surface
Engine stopped/shutdown (see your -10)
Carrier blocked (see your -10)
Track shroud and covers removed (page 22-2)
Road wheel removed (page 22-7)
Torsion bar removed (page 22-32)
Power plant removed (page 5-12) for second
torsion bar anchor, right side only

REMOVE

1. Remove two cotter pins (1) and pins (2) from torsion bar anchor (3). Discard cotter pins.
2. Remove two screws (4) from anchor (3) on fifth torsion bar anchors (M106A2, M1064, and M125A2 only).
3. Remove anchor (3) and preformed packing (5) from hull mount. Discard preformed packing.

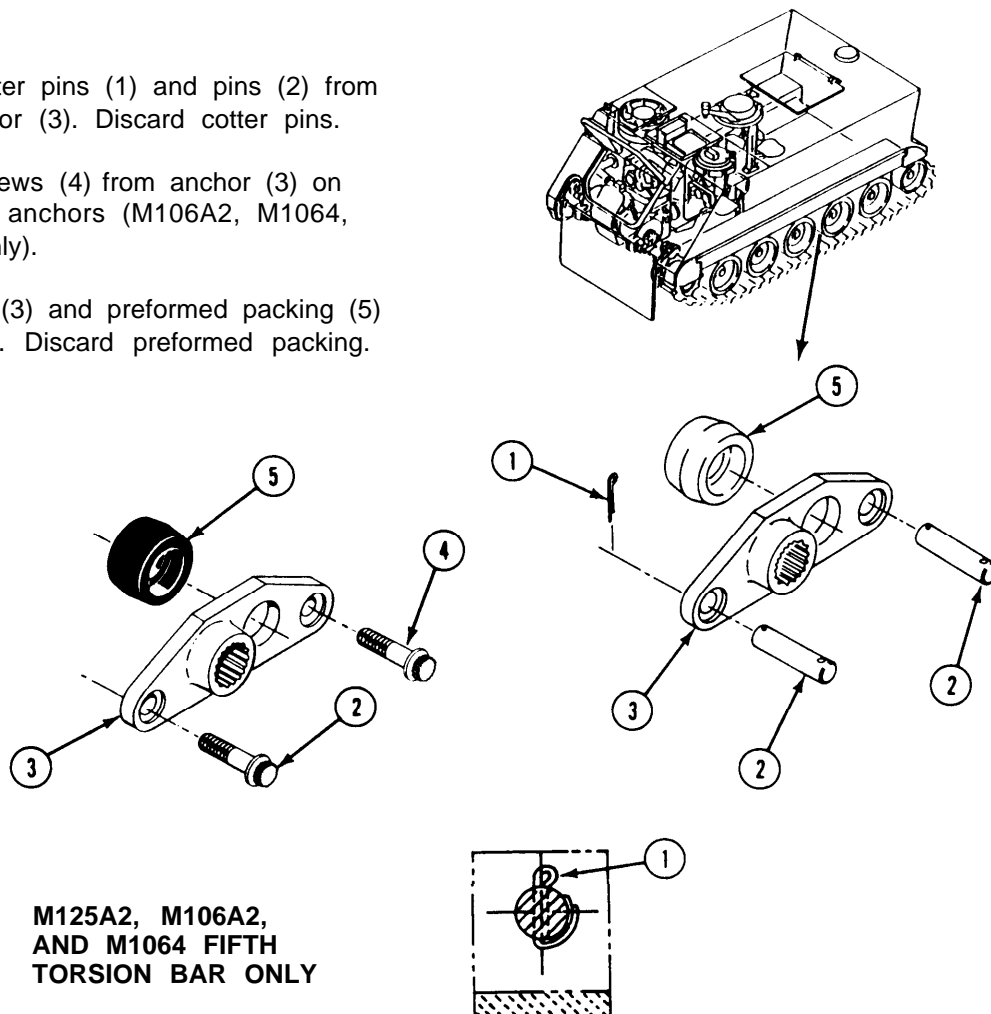

M125A2, M106A2,
AND M1064 FIFTH
TORSION BAR ONLY

CLEAN, INSPECT, AND REPLACE

4. Check torsion bar anchor and pins for wear and damage. Replace if needed.

INSTALL

NOTE

Preformed packing (1) is installed on third, fourth, and fifth anchor on all carriers except M741A1. Preformed packing is not required on the M741A1.

5. Place new preformed packing (1) and torsion bar anchor (2) on hull mount.
6. Install two screws (3) in anchor (2) on fifth torsion bar anchor (M106A2, M1064, and M125A2 only). Tighten screws to 320-330 lb-ft (434-447 N·m) torque. Use torque wrench.

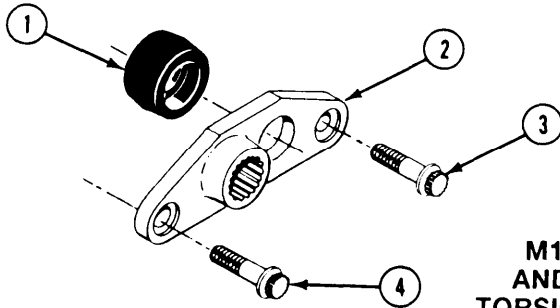

7. On all other carriers and torsion bar positions, install two pins (4) in anchor (2). Secure pins with two new cotter pins (5). Bend pins as shown.

NOTE

Cotter pins must not prevent 360 degree rotation of anchor pins.

8. Bend cotter pins (5) so they allow 360 degree rotation of anchor pins.

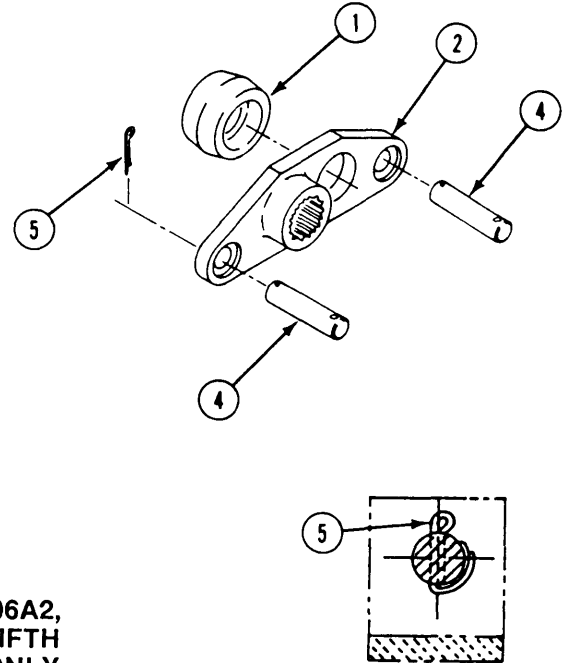

FOLLOW-THROUGH STEPS

1. Install torsion bar (page 22-32).
2. Install power plant (page 5-12) for second torsion bar anchor, right side only.
3. Install road wheel (page 22-7).
4. Install track shroud and covers (page 22-2).
5. Remove blocks used to keep carrier from moving (see your -10).
6. Road test earner (page 2-101) to check that torsion bar anchor is installed properly.
7. Stop/shutdown engine (see your -10).

END OF TASK

**CHAPTER 23
DRIVER'S CONTROLS**

Section I. STEERING CONTROLS

TASK INDEX

<u>Task</u>	<u>Page</u>	<u>Task</u>	<u>Page</u>
Adjust Steering Linkage	23-2	Replace Differential Cross-Shafts and Bearings	23-16
Adjust Brake Locking Pawl	23-4	Replace Differential Cross-Shaft Links	23-19
Repair Left/Right Steering Levers.	23-7	Replace Differential Steering Brake Levers	23-20
Replace Steering Levers Cross-Shafts and Bearings.	23-10		
Replace Steering Levers Cross-Shaft Links	23-14		



ADJUST STEERING LINKAGE

INITIAL SETUP

Tools:

General Mechanics Tool Kit (Item 30, App D)

Materials/Parts

Cotter pin (2)
Screw 3/8-16 x 2-1/2 (2)

Personnel Required:

Unit Mechanic
Helper (H)

References:

See your -10

Equipment Conditions:

Engine stopped/shutdown (see your 10)
Carrier blocked (see your -10)
Ramp lowered (see your -10)
Trim vane lowered and power plant front access door open (see your -10)
Driver's power plant access cover removed (page 24-25)
Battery ground leads disconnected (page 13-2)

ADJUST

NOTE

In most cases, adjustment of differential brake linkage is necessary only when a component of the control linkage has been repaired or replaced.

1. Remove air cleaner housing and element (page 7-7).

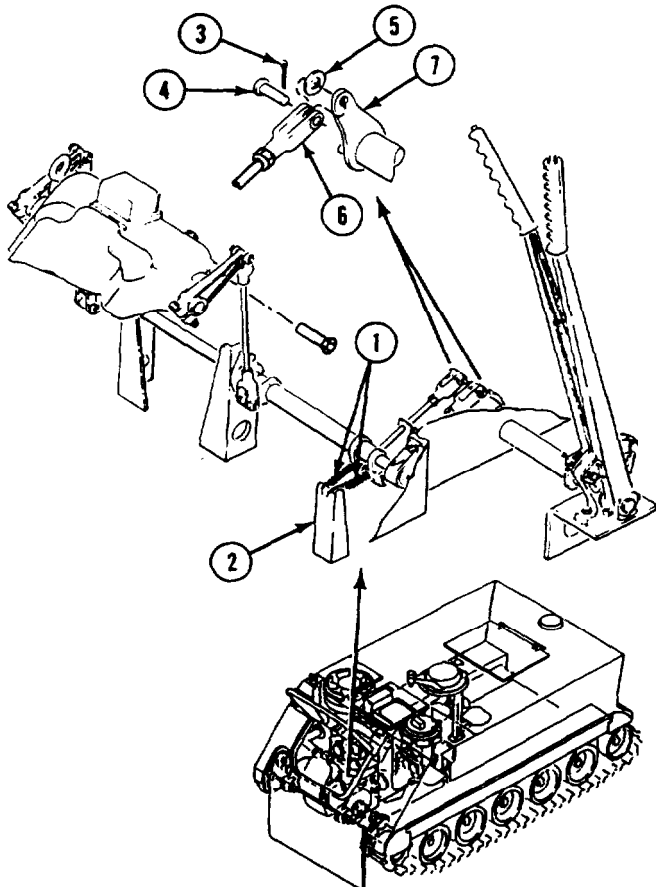

2. Unlock and release steering levers. Disconnect two return springs (1) from bracket (2).
3. Remove cross-shaft access covers (page 23-10).
4. Remove two cotter pins (3), clevis pins (4), and washers (5) from two clevises (6) and steering lever cross-shaft (7). Discard cotter pins.

NOTE

If holes in differential brake levers will not align with tapped holes in differential housing, loosen adjustment by turning brake adjusting nut to left until holes align. Re-adjust differential brakes (page 21-18).

5. Align holes in differential brake levers (8) with tapped holes in differential housing. Secure with two screws (9).

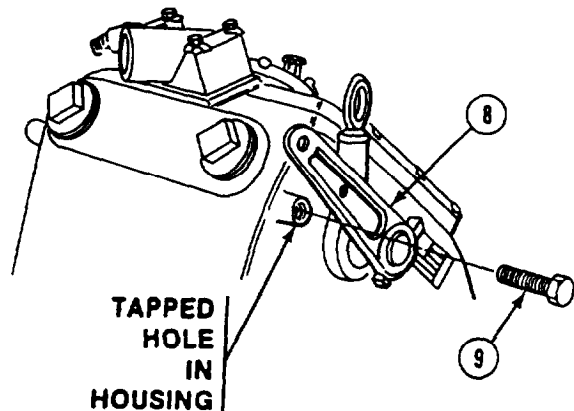

6. Lock steering levers (1 and 2) in front notch of quadrant (3).
7. Loosen two jamnuts (4) and turn two clevises (5) until clevis holes align with steering lever cross-shaft (6) holes.

NOTE

Before installing clevis pin through clevis and cross shaft levers, ensure stoplight switch lever is on proper side of linkage tabs (the side toward front of vehicle) then check and adjust stoplight switch if necessary (page 12-132).

8. Install clevises (5) to steering cross-shaft (6). Secure with two clevis pins (7), washers (8), and new cotter pins (9).
9. Tighten two jamnuts (4).
10. Remove two screws (10) from differential brake levers (11). Release steering lever to full forward position.
11. Connect two return springs (12) to brackets (13).
12. Install linkage access covers (page 23-10).
13. Install air cleaner housing and element (page 7-7).

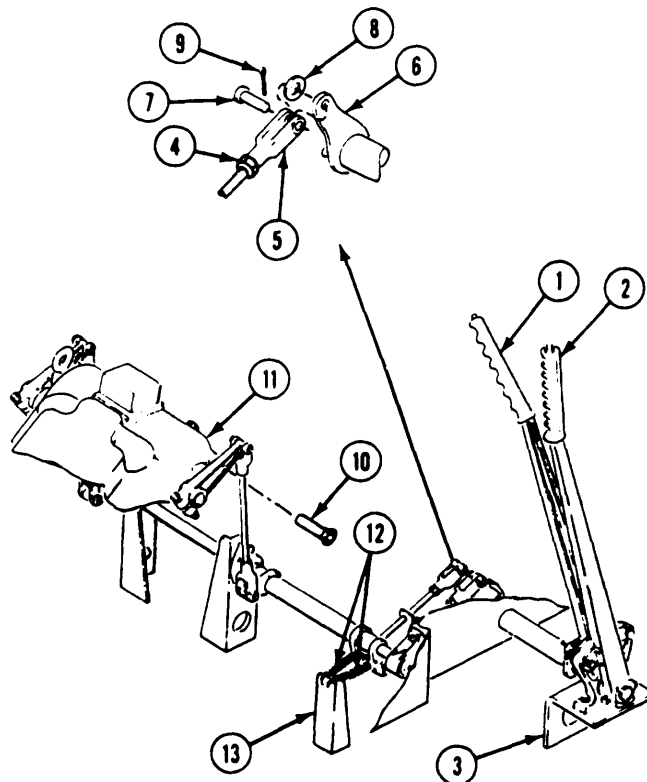

FOLLOW-THROUGH STEPS

- | | |
|--|---|
| <ol style="list-style-type: none"> 1. Perform differential brake adjustment (page 21-18). 2. Close power plant front access door and raise trim vane (see your -10). 3. Install driver's power plant access cover (page 24-25). | <ol style="list-style-type: none"> 4. Connect battery ground leads (page 13-2). 5. Raise and lock ramp (see your -10). 6. Unlock steering levers. Operate earner to check that steering brakes operates properly. 7. Stop/shutdown engine (see your -10). |
|--|---|

END OF TASK

ADJUST BRAKE LOCKING PAWL

INITIAL SETUP

Tools:

General Mechanics Tool Kit (Item 30, App D)
 Drill Set (Item 24, App D)

Materials/Parts:

Cotter pin (2)
 Self-locking nut (2)
 spring pin (4)

Personnel Required:

Unit Mechanic

References:

See your -lo

Equipment Conditions:

Engine stopped/shutdown (see your -10)
 Carrier blocked (see your -10)
 Trim vane lowered and power plant front access door open (see your -10)
 Driver's seat removed (page 25-127)
 Remove air cleaner housing and element (page 7-7)

ADJUST



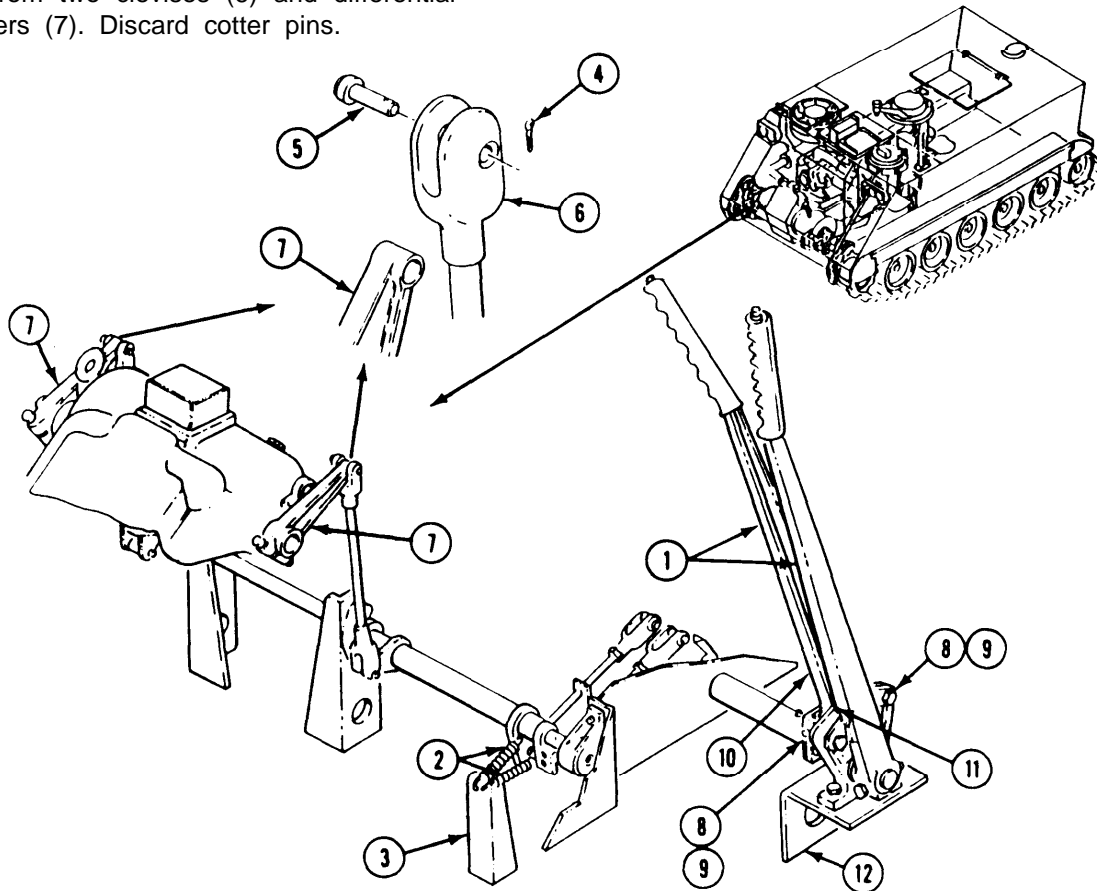



1. Unlock both steering levers (1).
2. Disconnect two return springs (2) from bracket (3).
3. Remove two cotter pins (4) and two clevis pins (5) from two clevises (6) and differential brake levers (7). Discard cotter pins.
4. Remove two screws (8), locknuts (9), two quadrants (10), and stops (11) from bracket (12). Discard locknuts.
5. Place quadrants (10) and stops (11) on bracket (12). Install screws (8) and new locknuts (9), push down on quadrants while screws and locknuts are tightened.



6. Check gap between pawls (1) and top of quadrants (2) while moving steering levers (3) from front to back. Use 5/32, 3/16, and 7/32 inch (4, 5, and 6 mm) diameter drill bit shanks to check gap. Clearance should be between 5/32 (4 mm) and 7/32 (6 mm). If 5/32 or 3/16 inch (4 and 5 mm) drills will fit but 7/32 inch (6 mm) drill will not, gap is right. If 7/32 inch (6 mm) drill will fit, it must be snug in gap throughout lever travel for gap to be right.
7. If gap is wrong, do steps 9 through 17 while referring to pawl adjustment chart. If gap is correct, go to step 18.
8. Loosen front quadrant screw (4) and locknut (5) that secure quadrants (2) to bracket (6).
9. Remove rear screw (4) and locknut (5) from bracket (6) and quadrants (2).
10. Remove three washers (7), spring (8), and two spring pins (9) from plunger rod (10), remove from steering lever (3). Discard spring pins.
11. Loosen pawl jamnuts (11) to adjust pawl (1) to quadrant clearance.
12. Set clearance between 5/32 inch (4 mm) and 7/32 inch (6 mm). Then tighten jamnuts (11). One complete turn will move pawl (1) 1/32 inch (0.8 mm).

PAWL ADJUSTMENT CHART

**NOTE
USE COMMON DRILL BITS TO MEASURE
GAP BETWEEN PAWL AND QUADRANT**

A			B
DRILL DIA IN	METRIC DIA MM		MOVE PAWL
1/32	0.8		5 FULL TURNS
1/16	2		4 FULL TURNS
3/32	2		3 FULL TURNS
1/8	3		2 FULL TURNS
5/32	4		1 FULL TURN
3/16	5		0 TURNS
7/32	6		BACK 1 FULL TURN

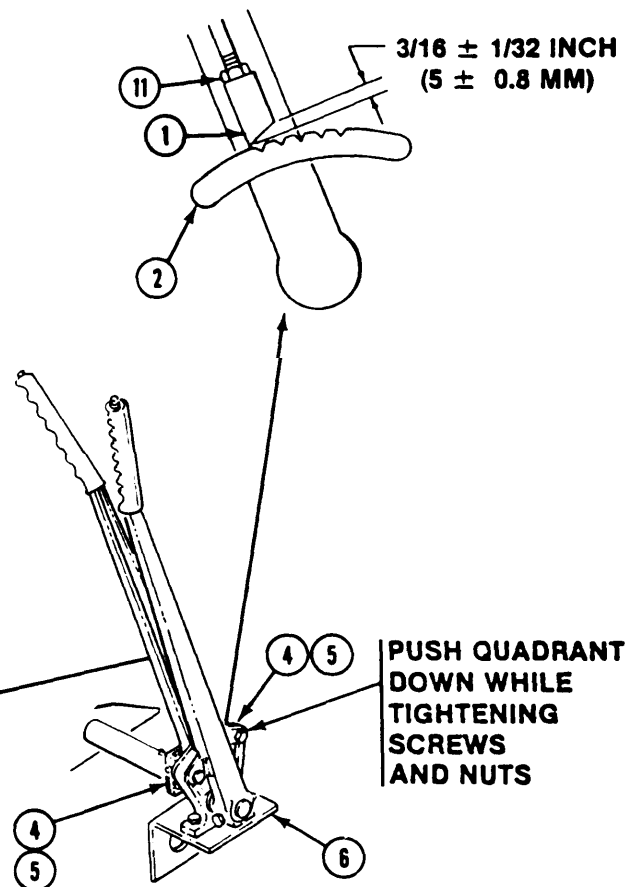
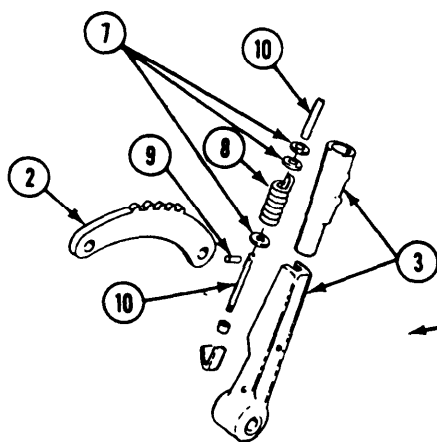

GO TO NEXT PAGE

13. Place plunger rods (1) back in steering levers (2). Secure each rod with three washers (3) spring (4) and new spring pins (5).
14. Install rear screw (6) and locknut (7) in quadrants (8) and bracket (9).
15. Push quadrants (8) completely down. Tighten two screws (6) and locknuts (7).
16. Check gap between pawls (10) and quadrants (8) while moving steering levers (2) as in step 7 above.
17. Install two clevises (11) to two differential brake levers (12). Secure with clevis pins (13) and new cotter pins (14).
18. Connect two springs (15) to hull bracket (16).

CAUTION

Make sure button (17) on top of steering levers (2) works freely. Pawl (9) must fully engage quadrant with steering lever back and button pressed. Button must pop up and pawl disengage from quadrant with slight pull on steering lever. Plunger rods (1) must move freely without binding.

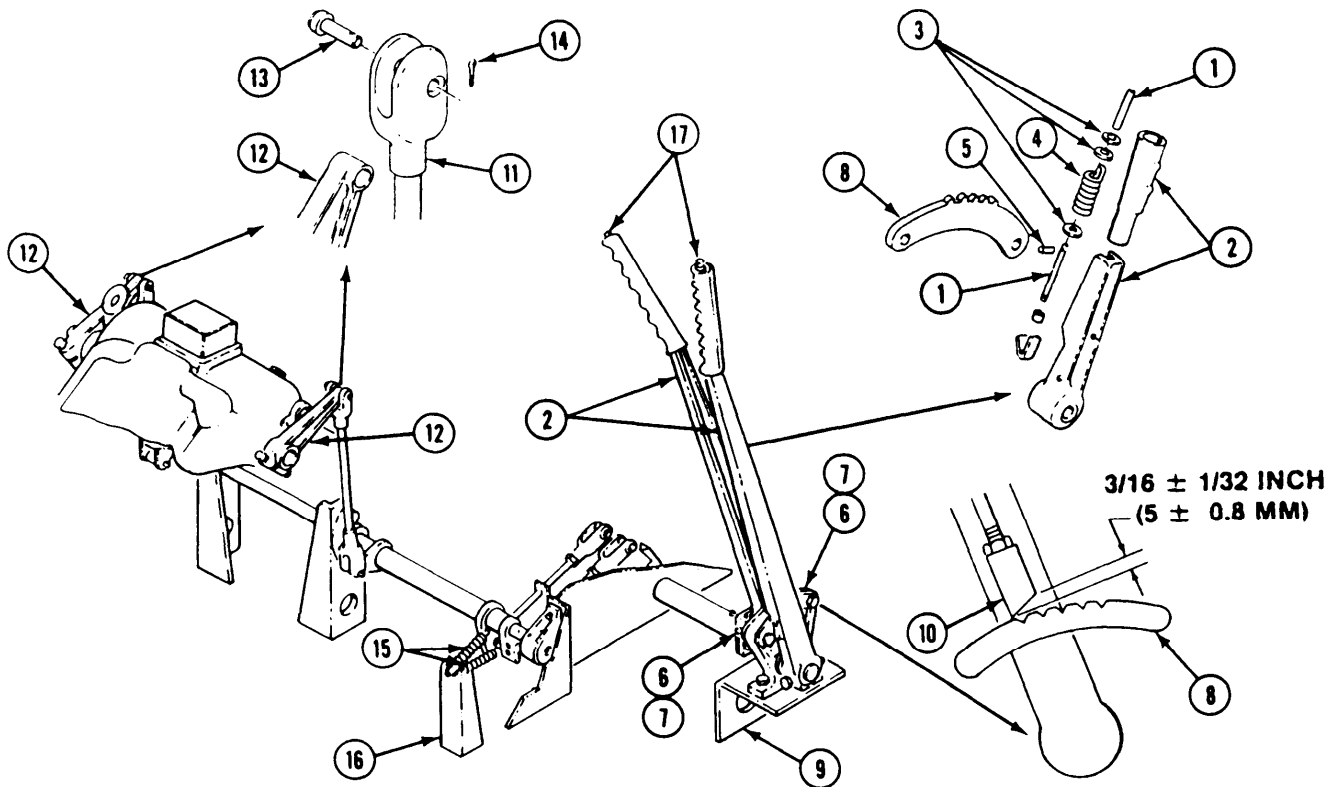

FOLLOW-THROUGH STEPS

1. Install air cleaner housing and element (page 7-7).
2. Close power plant front access door and raise trim vane (see your -10).
3. Install driver's seat (page 24-127).
4. Operate carrier (see your -10). Check that steering brakes operates properly.

END OF TASK

REPAIR LEFT/RIGHT STEERING LEVERS

DESCRIPTION

This task covers: Remove (page 23-7). Clean, Inspect, and Replace (page 23-8).
Install (page 23-8).

INITIAL SETUP

Tools:

General Mechanics Tool Kit (Item 30, App D)
Snap Ring Pliers (Item 45, App D)
Socket Wrench Set (Item 89, App D)
Torque Wrench (Item 95, App D)

Materials/Parts:

Self-locking nut (2)
Self-locking nut (2)
Self-locking nut (2)
Spring pin (3)

Personnel Required:

Unit Mechanic

References:

see your -1o

Equipment Conditions:

Engine stopped/shutdown (see your -10)
Carrier blocked (see your -10)
Driver's seat removed (page 24-127)

REMOVE

1. Place right and left steering levers (1 and 2) full forward, in released position.
2. Remove screw (3), locknut (4), and left steering lever (2) from cross-shaft (5). Remove woodruff key (6) from cross-shaft. Discard locknut.

4. Remove bracket (9) from cross-shaft (5).
5. Remove two screws (11), two stop levers (12), two quadrants (13) and two locknuts (14) from bracket (9). Discard locknuts.
6. Remove two retaining rings (15), one bearing (16) from inside bracket (9).
7. Remove screw (17), locknut (18), and right steering lever (1) from cross-shaft (5). Discard locknut.

NOTE

The same number of shims removed will be installed.

3. Remove two screws (7), washers (8), bracket (9), and shims(10) from driver's floor plate.

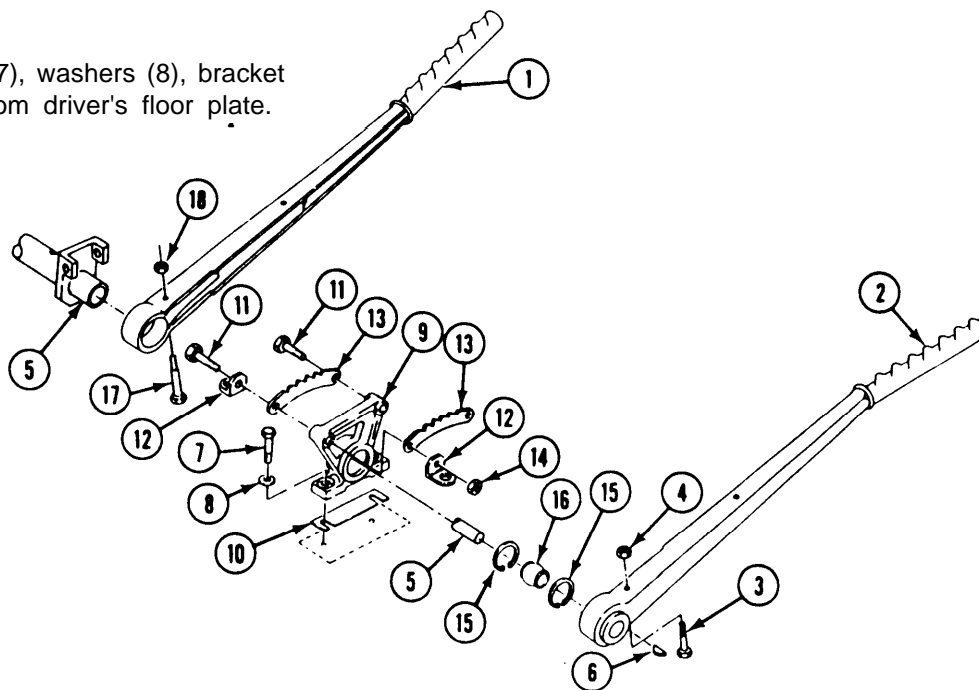

GO TO NEXT PAGE

NOTE

Both right and left steering levers, in this section are removed and installed the same way.

8. Remove spring pin (1) from plunger (2). Remove plunger from rod (3). Discard spring pin.
9. Remove two spring pins (4) from rod (3). Discard spring pins.
10. Remove rod (3), three washers (5), and spring (6) from lever arm (7).
11. Remove nut (8), pawl (9), and nut sleeve (10) from rod (3).
12. Remove locknut (11), flat washer (12), washer (13), bolt (14) and rod clip (15) from steering lever (7). Discard locknut.

CLEAN, INSPECT, AND REPAIR

13. Check lever arm, button, and spring. Replace cracked or broken parts.
14. Check all threads. Replace parts with stripped threads.
15. Check pawl. Replace nicked or worn pawl.
16. Check bearing, bracket, retaining rings, and quadrants for wear or damage. Replace all damaged parts.

INSTALL

17. Install rod clip (15) on steering lever (7). Secure with bolt (14), flat washer (12), washer (13) and new locknut (11).
18. Install nut sleeve (10), nut (8) and pawl (9) on rod (3).
19. Install three washers (5), spring (6) on rod (3).
20. Install parts assembled in steps (18 and 19) on steering lever (7). Secure with two new spring pins (4).
21. Install plunger (2) in rod (3). Secure with new spring pin (1).

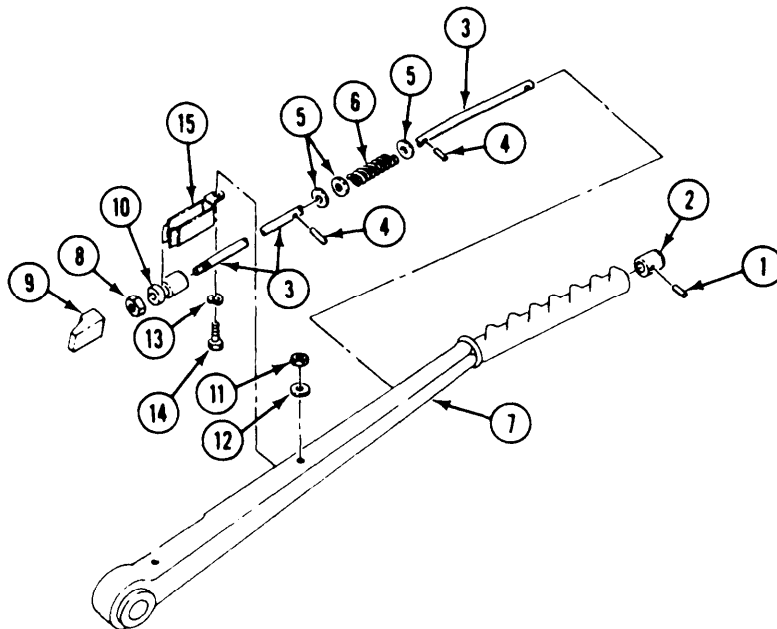

22. Install right steering lever (1) on cross-shaft (2). Secure With new locknut (3), and screw (4).
23. Install bearing (5) in bracket (6) and secure with two retaining rings (7). Use snap ring pliers.
24. Install two quadrants (8), two stop levers (9), on bracket (6) with two screws (10) and new locknuts (11).
25. Install bracket (6) on cross-shaft (2). Install shims (12) between bracket (6) and driver's floor plate. Secure with two washers (13) and screws (14).
26. Install left steering lever (15) on cross-shaft (2). Secure with woodruff key (16), new locknut (17), and screw (18).

NOTE

The same number of shims removed will be installed.

27. Tighten locknut (17) to 204–240 lb-in (23–27 N·m) torque.

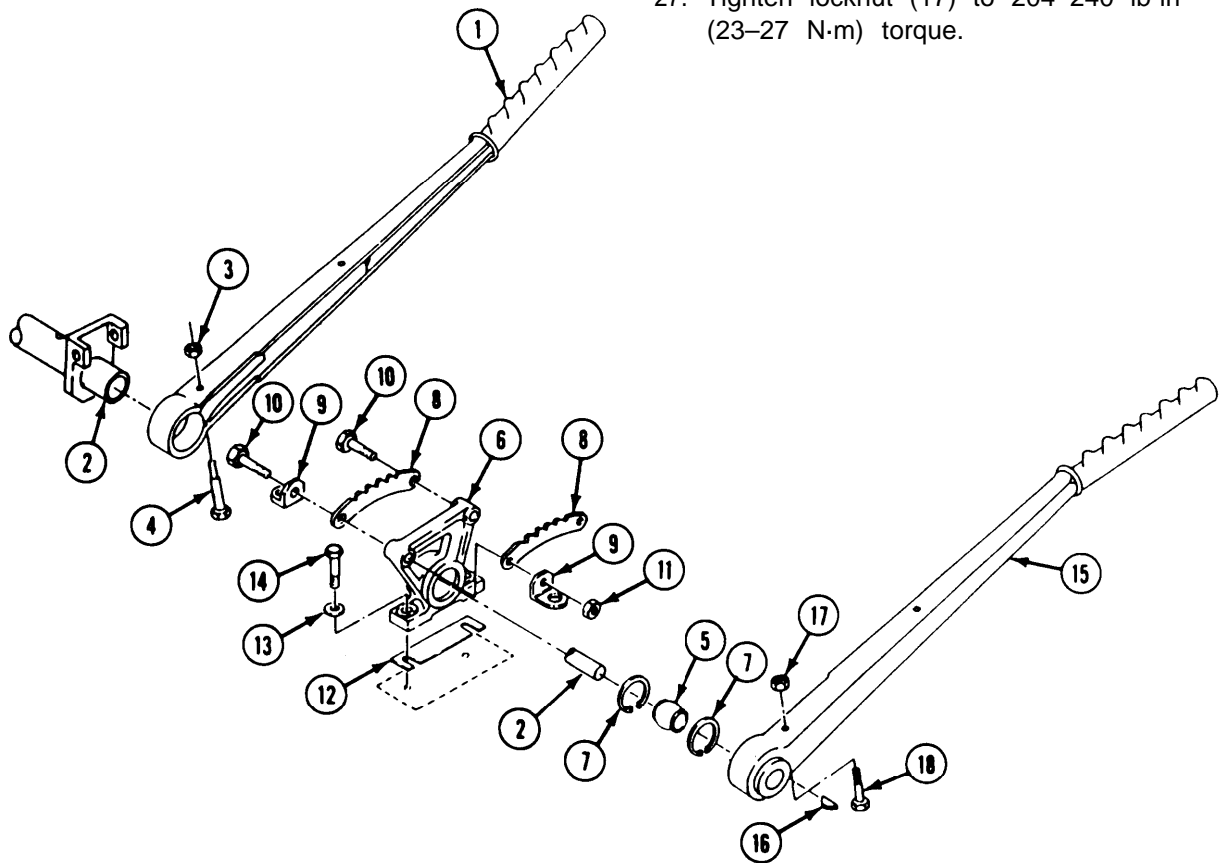

FOLLOW-THROUGH STEPS

1. Adjust brake locking pawl (page 23-4).
2. Install driver's seat (page 24-127).
3. Operate earner (see your -10). Check that steering levers operate properly.

END OF TASK

REPLACE STEERING LEVERS CROSS-SHAFTS AND BEARINGS

DESCRIPTION

This task covers: Remove (page 23-10). Install (page 23-12).

INITIAL SETUP

Tools:

General Mechanics Tool Kit (Item 30, App D)
Snap Ring Pliers (Item 45, App D)

References:

see your -lo
See your LO

Materials/Parts:

Cotter Pin (2)
Gasket
Self-locking nut (2)
Self-locking nut (2)
Self-locking nut (5)
Tapered Pin (2)

Equipment Conditions:

Engine stopped/shutdown (see your -10)
Carrier blocked (see your -10)
Ramp lowered (see your -10)
Trim vane lowered and power plant front access door open (see your -10)
Driver's power plant access panel removed (page 24-25)
Air cleaner housing and element removed (page 7-7)
Oil can bracket removed (page 24-237)
Driver's seat removed (page 24-127)

Personnel Required:

Unit Mechanic

REMOVE

1. Disconnect two return springs (page 23-2).
2. Remove steering levers, bracket, and shim (page 23-7).
3. Remove two screws (1), locknuts (2), stops (3), and quadrants (4) from bracket (5). Discard locknuts.
4. Remove two retaining rings (6) and bearing (7) from bracket (5).

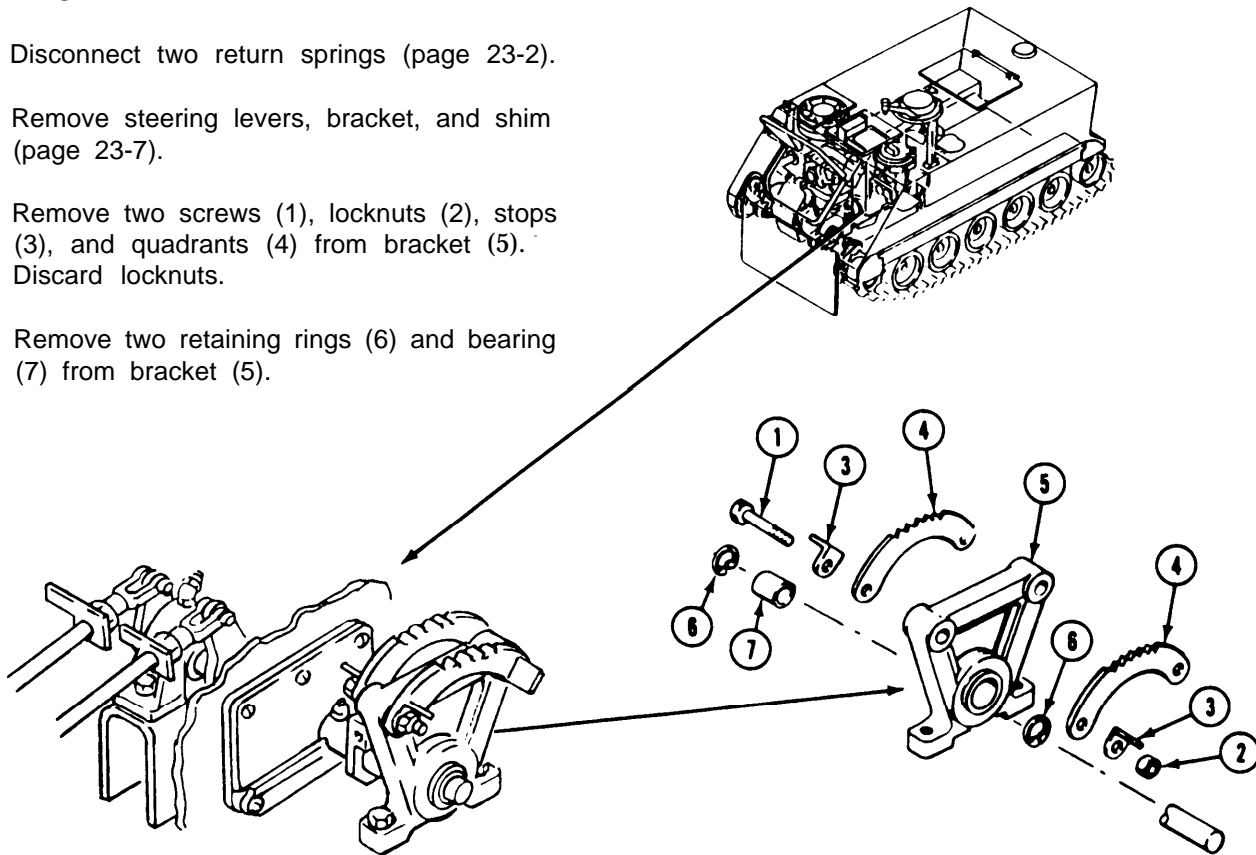

5. Remove two cotter pins (1), clevis pins (2), and washers (3) that secure two clevises (4) to cross shafts (5 and 6). Discard cotter pins.
6. Remove five screws (7), washers (8), and locknuts (9) that secure covers (10 and 11) and gasket (12) to five press nuts (13) in power plant compartment bulkhead. Discard gasket and locknuts.
7. Remove two screws (14), washers (15), locknuts (16), tapered pins (17), arm bearing (18), and shim (19) from bracket (20). Discard tapered pins and locknuts.
8. Remove cross-shafts (5 and 6) and arm bearing (18) as a unit through power plant compartment bulkhead.
9. Separate cross-shafts (5 and 6), arm bearing (18), and two thrust washers (21).
10. Remove lubrication fittings (22) from arm bearing (18) and cross-shaft (5).

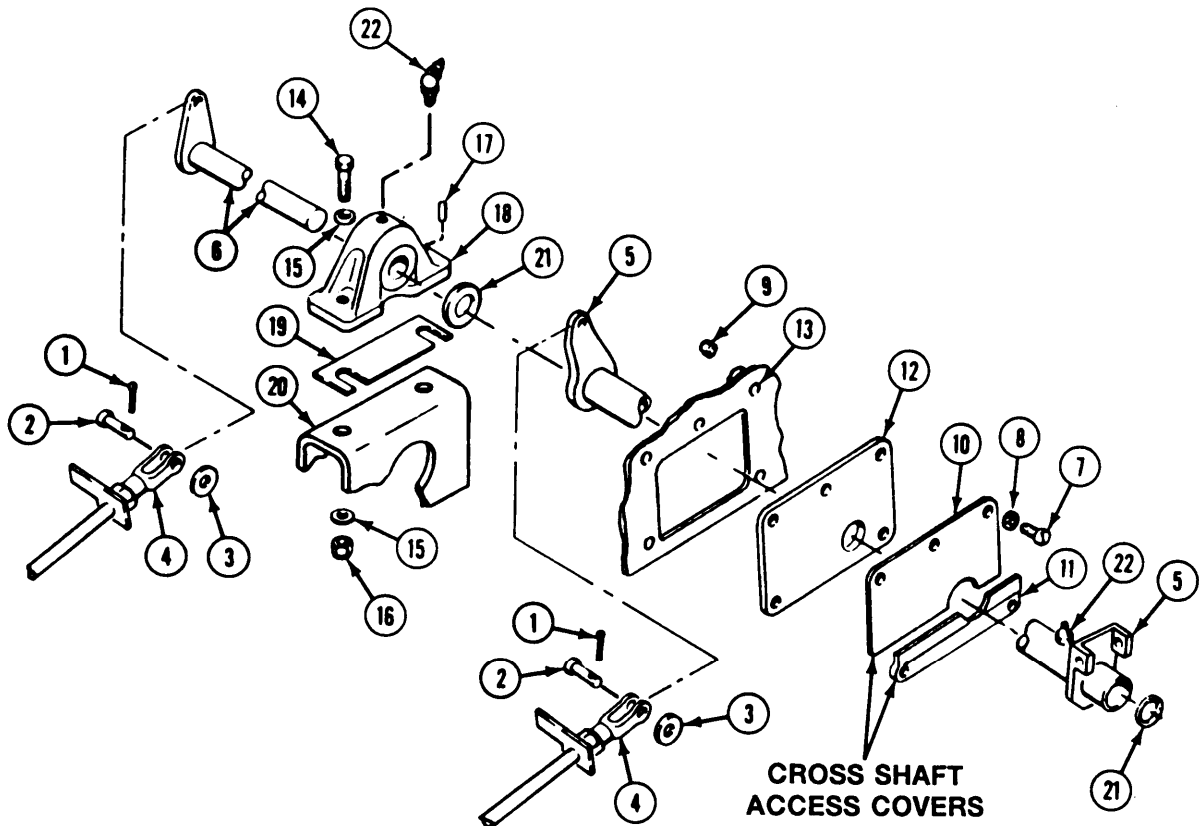

GO TO NEXT PAGE

INSTALL

NOTE

If arm bearing (1) is to be replaced, use shim (2) as a template to locate and drill two .250-.252 inch (6mm) holes in base of new bearing before installation. If there is no shim, make template from old bearing.

11. Assemble cross-shafts (3 and 4), arm bearing (1), lube fittings (5), and two thrust washers (6) as a unit. Install through power plant compartment bulkhead opening.
12. Place shim (2) and bearing (1) on bracket (7). Secure with two new tapered pins (8), new locknuts (9), washers (10), and screws (11).
13. Install two clevises (12) on cross-shafts (3 and 4). Secure with two clevis pins (13), washers (14) and new cotter pins (16).
14. Install new gasket (16) and covers (17 and 18) on five press nuts (19) in power plant compartment bulkhead. Secure with five new locknuts (20), screws (21), and washers (22).
15. Install bearing (23) in bracket (24). Secure with two retaining rings (25). Use snap ring pliers.
16. Install two quadrants (26) and stops (27) on bracket (24). Secure with two screws (28) and new locknuts (29).

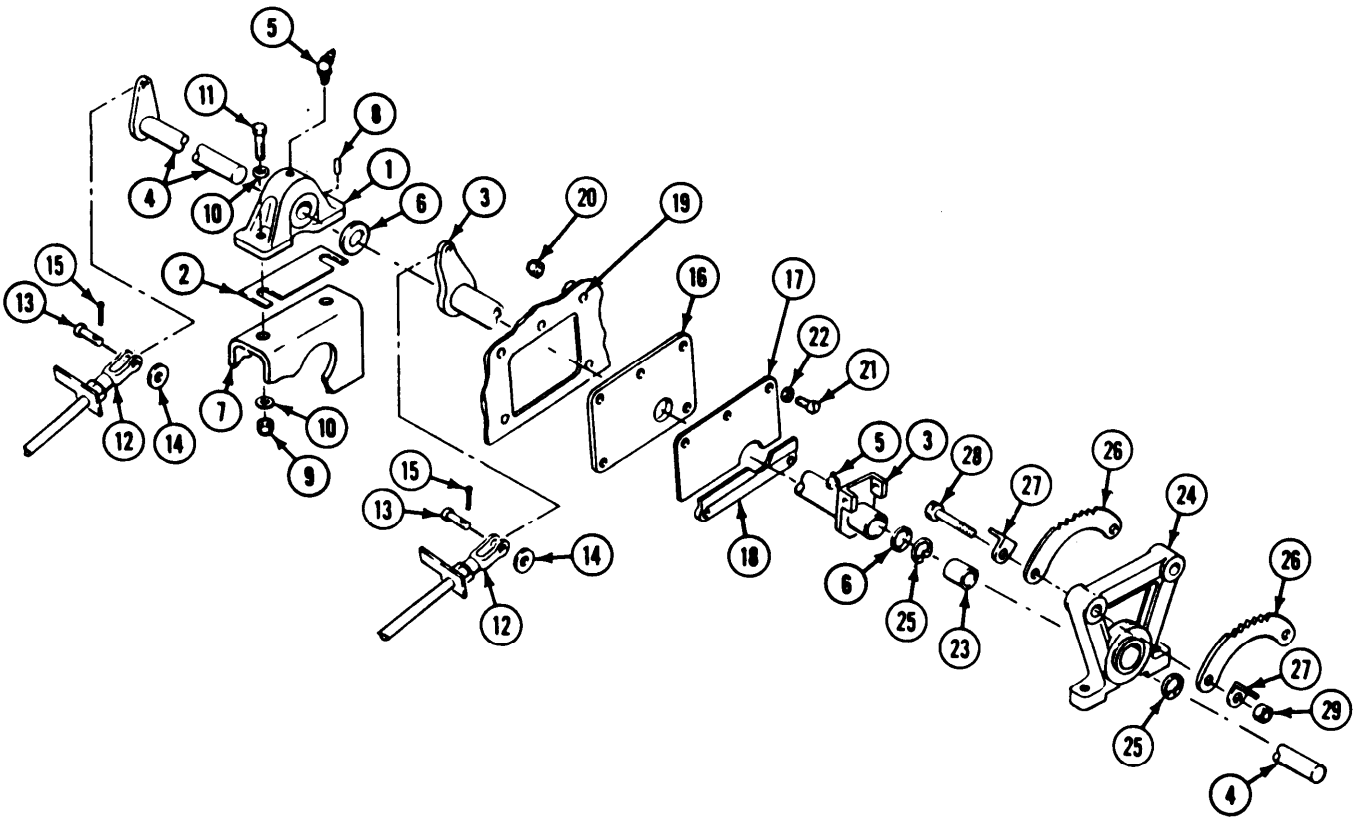

17. Install steering levers, bracket, and shim (page 23-7).
18. Adjust brake locking pawl (page 234).

19. Lubricate cross-shafts (1 and 2) and arm bearing (3) (see your LO).
20. Connect two return springs (page 23-2).

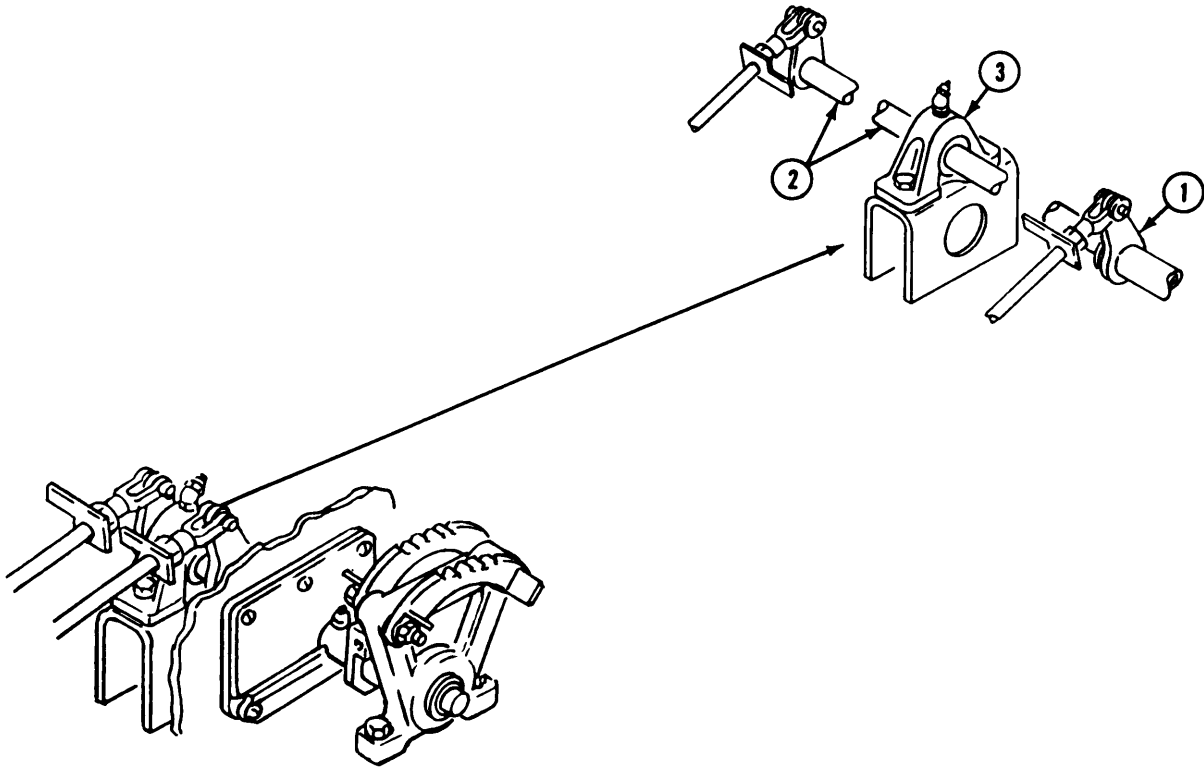

FOLLOW-THROUGH STEPS

1. Install oil can bracket (page 24-237).
2. Install air cleaner housing and element (page 7-7).
3. Close power plant front access door and raise trim vane (see your -10).
4. Install driver's power plant access panel (page 24-25).
5. Install driver's seat (page 24-127).
6. Raise and lock ramp (see your -10).
7. Operate carrier (see your -10). Check that the steering operates properly.
8. Stop/shutdown engine (see your -10).

END OF TASK

REPLACE STEERING LEVERS CROSS-SHAFT LINKS

DESCRIPTION

This task covers: Remove (page 23-14). Clean, Inspect, and Repair (page 23-15).
Install (page 23-15).

INITIAL SETUP

Tools:

General Mechanics Tool Kit (Item 30, App D)

Materials/Parts:

Cotter pin (4)

Personnel Required:

Unit Mechanic

References:

See your -10

Equipment Conditions:

Engine stopped/shutdown (see your -10)
Carrier blocked (see your -10)
Trim vane lowered and power plant front access door open (see your -10)
Driver's power plant access panel removed (page 24-25)
Brakes released, steering levers full forward (see your -10)
Air cleaner housing and element removed (page 7-7)
Oil can bracket removed (page 24-237)

REMOVE

1. Disconnect two return springs (page 23-2).
2. Remove cross-shaft covers from power plant compartment bulkhead (page 23-11).
3. Remove four cotter pins (1), clevis pins (2) and two links (3) from steering levers and differential cross-shafts. Discard cotter pins.

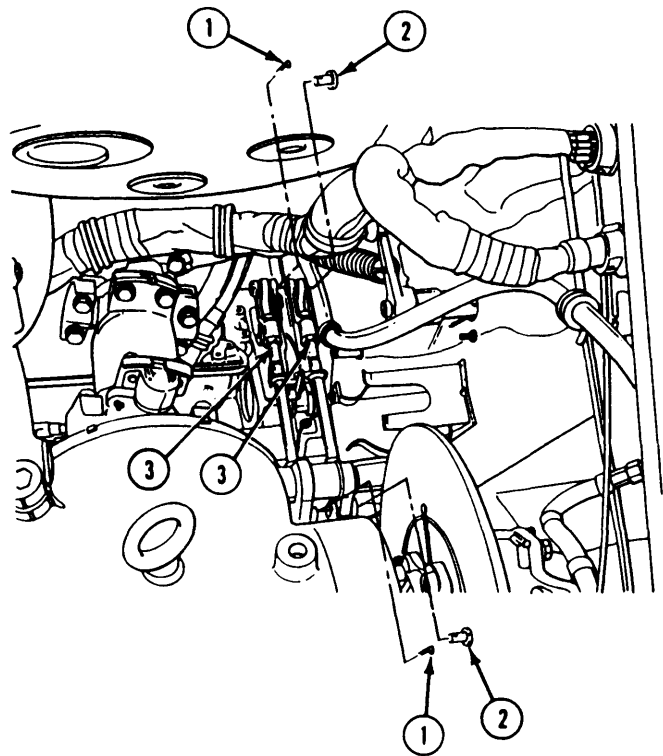

CLEAN, INSPECT, AND REPAIR

4. Check links. Replace links with cracks, breaks, or stripped threads.
5. Check link clevises. Replace link clevises with cracks or worn mounting holes.
6. Check clevis pins. Replace worn or grooved clevis pins.
7. Check stop light tangs. Replace links with cracked or broken tangs.

INSTALL

8. Install two links (1) on steering levers and differential cross-shafts. Secure with four clevis pins (2) and four new cotter pins (3).
9. Adjust linkage (page 23-2).
10. Adjust stop light switch (page 12-132).
11. Connect two return springs (page 23-2).
12. Install cross-shaft covers on power plant compartment bulkhead (page 23-11).

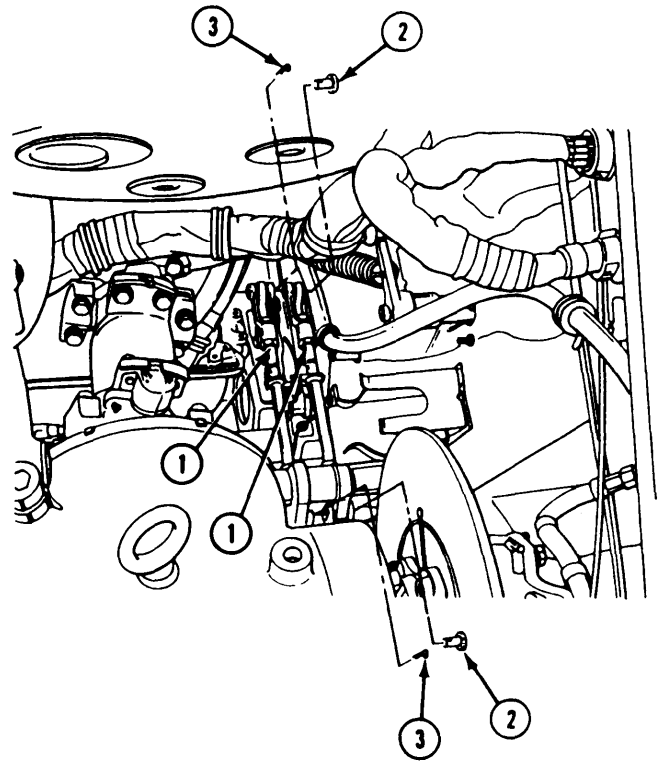

FOLLOW-THROUGH STEPS

1. Install oil can bracket (page 24-237).
2. Install air cleaner housing and element (page 7-7)
3. Install driver's power plant access panel (page 24-25).
4. Close power plant front access door and raise trim vane (see your -10).
5. Operate carrier (see your -10). Check that the steering operates properly.

END OF TASK

REPLACE DIFFERENTIAL CROSS-SHAFTS AND BEARINGS

DESCRIPTION

This task covers: Remove (page 23-16). Clean, Inspect, and Repair (page 23-17).
Install (page 23-17).

INITIAL SETUP

Tools:

General Mechanics Tool Kit (Item 30, App D)
Snap Ring Pliers (Item 45, App D)

References:

See your -10
See your LO

Materials/Parts:

Cotter pin (4)
Self-locking nut (3)
Self-locking nut (4)

Equipment Conditions:

Engine stopped/shutdown (see your -10)
Carrier blocked (see your -10)
Trim vane lowered and power plant front access door open (see your -10)
Air cleaner housing and element removed (page 7-7)
Oil can bracket removed (page 24-237).

Personnel Required:

Unit Mechanic
Helper (H)

REMOVE

1. Disconnect two return springs (page 23-2).
2. Remove four cotter pins (1), clevis pins (2), and links (3) from differential and steering lever cross-shafts (4 and 5) and link arm (6). Discard cotter pins.
3. Remove four screws (7), washers (8), and locknuts (9) that secure two bearings (10) to two brackets (11). Discard locknuts.
4. Remove two screws (12), four washers (13), and two locknuts (14) that secure bearing (15) and shim (16) to driver's compartment bulkhead. Discard locknuts.
5. Remove differential and steering cross-shafts (4 and 5), bearings (10 and 15), and link arm (6) from power plant compartment as a unit.
6. Remove screw (17), locknut (18), and link arm (6) from cross-shaft (4). Remove wood-ruff key (19) from cross-shaft. Discard locknut.

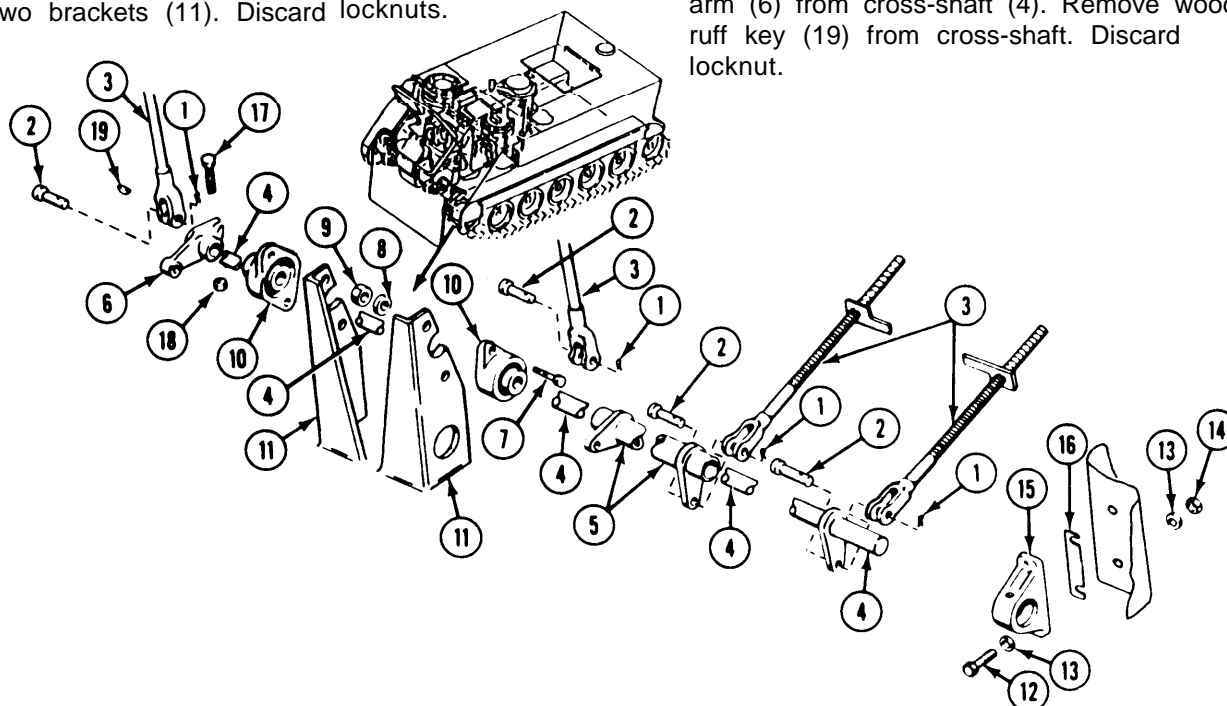

- 7 . Remove bearing (1) from cross-shaft (2).
- 8 . Loosen four set screws (3) in two bearing collars (4).
- 9 . Separate cross-shafts (2 and 5), two bearings (6), and two thrust washers (7).
- 10 . Remove two retaining rings (8), bearing (9), and lubrication fitting (10) from bearing (1).

CLEAN, INSPECT, AND REPAIR

- 11 . Check links. Replace links with cracks, breaks, or stripped threads.
- 12 . Check bearings, retaining rings, and fittings for cracks or wear. Replace damaged parts.

INSTALL

- 13 . Install bearing (9) in bearing (1). Secure with two retaining rings (8).
- 14 . Install lubrication fitting (10) in bearing (1).

- 15 . Assemble two cross-shafts (2 and 5), two bearings (6), two thrust washers (7), bearing (1), woodruff key (11), and link arm (12).
- 16 . Install screw (13) and new locknut (14) in link arm (12). Do not tighten nut.
- 17 . Place cross-shafts (2 and 5), two bearings (6), and bearing (1) as a unit on two brackets (15).
- 18 . Install two bearings (6) on two brackets (15). Secure with four screws (16), washers (17), and new locknuts (18).
- 19 . Install bearing (1) and shim (19) to driver's compartment bulkhead. Secure with two screws (20), four washers (21), and two new locknuts (22).
- 20 . Install four links (23) to cross-shafts (2 and 5) and link arm (12). Secure with four clevis pins (24) and new cotter pins (25).
- 21 . Tighten four set screws (3) in two bearing collars (4).
- 22 . Tighten nut (14) on link arm (12).

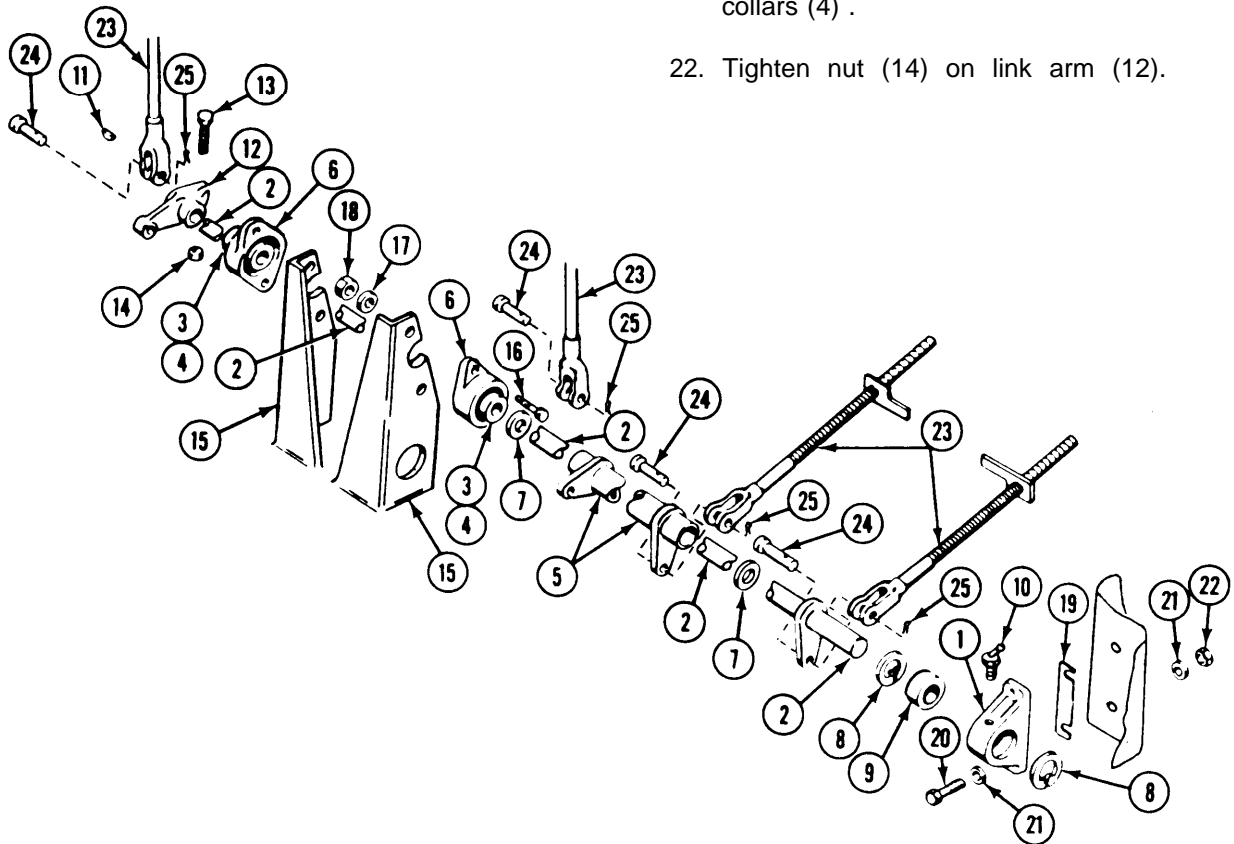

GO TO NEXT PAGE

23. Lubricate bearing (1) (see your LO).
 24. Connect two return springs (page 23-2).
 25. Install oil can bracket (page 24-237).
 26. Install air cleaner housing and element (page 7-7).
-

FOLLOW-THROUGH STEPS

1. Close power plant front access door and raise trim vane (see your -10).
 2. Operate carrier (see your -10). Check that differential cross-shafts and bearings operate properly.
-

END OF TASK

REPLACE DIFFERENTIAL CROSS-SHAFT LINKS

INITIAL SETUP

Tools:

General Mechanics Tool Kit (Item 30, App D)

Materials/Parts:

Cotter pin (4)

Personnel Required:

Unit Mechanic

References:

See your -10

Equipment Conditions:

Engine stopped/shutdown (see your -10)

Carrier blocked (see your -10)

Trim vane lowered and power plant front access door open (see your -10)

REMOVE

1. Disconnect two return springs (page 23-2).
2. Remove four cotter pins (1), clevis pins (2), and two links (3) from differential steering levers (4) and differential cross-shafts (5). Discard cotter pins.

CLEAN, INSPECT, AND REPAIR

3. Check link rods. Replace cracked, bent, or broken links.
4. Check link clevises. Replace links with cracked or worn mounting holes.
5. Check clevis pins. Replace worn or grooved clevis pins.
6. Check springs. Replace cracked or worn springs.

INSTALL

7. Install two links (3) to differential steering levers (4) and differential cross-shafts (5). Secure with four clevis pins (2) and new cotter pins (1).
8. Adjust linkage (page 23-2).
9. Connect two return springs (page 23-2).

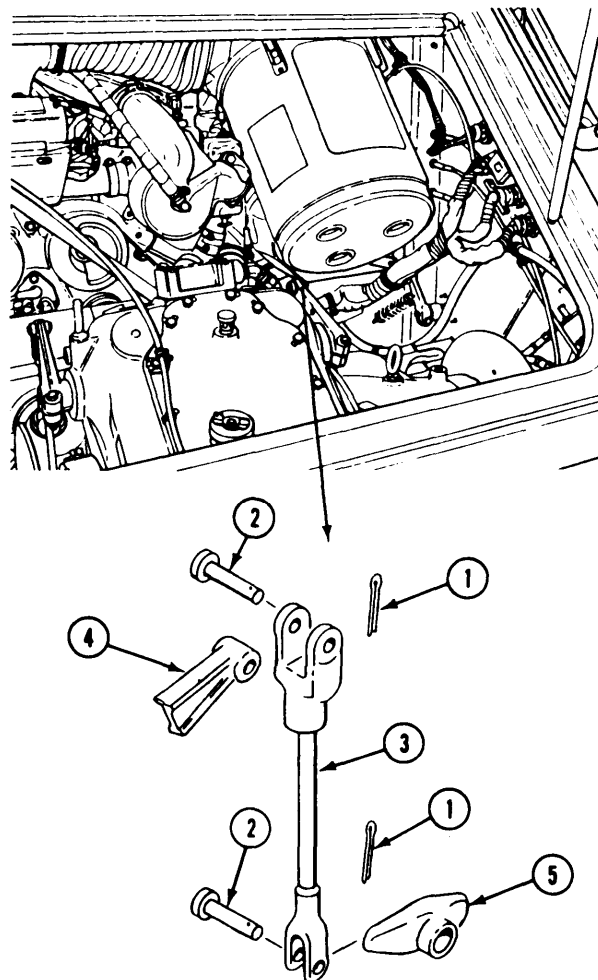

FOLLOW-THROUGH STEPS

1. Close power plant front access door and raise trim vane (see your -10).
 2. Operate steering levers to check that differential cross-shaft links operates properly.
-

END OF TASK

REPLACE DIFFERENTIAL STEERING BRAKE LEVERS

INITIAL SETUP

Tools:

General Mechanics Tool Kit (Item 30, App D)
Torque Wrench (Item 95, App D)

References:

See your -10

Materials/Parts:

Self-locking nut (2)

Equipment Conditions:

Engine stopped/shutdown (see your -10)
Carrier blocked (see your -10)
Trim vane lowered and power plant front
access door open (see your -10)

Personnel Required:

Unit Mechanic

REMOVE

1. Disconnect two return springs (page 23-2).
2. Disconnect two differential links (page 23-19).
3. Remove two locknuts (1), screws (2), and two brake levers (3) from differential brake lever shafts. Discard locknuts.

CLEAN, INSPECT, AND REPAIR

4. Check levers. Replace levers with cracked or worn clevis pin holes.
5. Check levers. Replace levers with damaged or chipped splines.

INSTALL

6. Install two levers (3) on differential brake lever shafts. Secure with two screws (2) and new locknuts (1).
7. Tighten nuts (1) to 360-420 lb-in torque. Use torque wrench.
8. Connect two differential links (page 23-19).
9. Adjust linkage (page 23-2).
10. Connect two return springs (page 23-2).

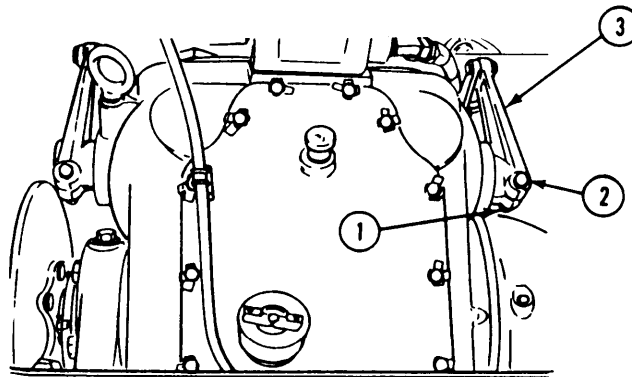

FOLLOW-THROUGH STEPS

1. Close power plant front access door and raise trim vane (see your -10).
 2. Operate steering levers to check that differential steering brake levers operate properly.
-

END OF TASK

**Section II. ACCELERATOR AND TRANSMISSION LINKAGE,
THROTTLE LINKAGE, AND FUEL CUTOFF CABLE**

TASK INDEX

<u>Task</u>	<u>Page</u>	<u>Task</u>	<u>Page</u>
Replace Lower Accelerator Pedal	23-22	Replace Upper Accelerator Linkage	23-31
Replace Upper Accelerator Pedal Assembly	23-23	Repair Upper Accelerator Linkage	23-33
Replace Transmission and Lower Accelerator Linkage	23-25	Adjust Accelerator and Transmission Throttle Valve Linkage	23-34
Repair Transmission and Lower Accelerator Linkage	23-29	Replace Hand Throttle	23-42
		Replace Fuel Cutoff Cable	23-44

REPLACE LOWER ACCELERATOR PEDAL

INITIAL SETUP

Tools:

General Mechanics Tool Kit (Item 31, App D)

Materials/Parts:

Cotter pin (2)

Personnel Required:

Unit Mechanic

References:

See your -10

Equipment Conditions:

Engine stopped/shutdown (see your -10)

Carrier blocked (see your -10)

Driver's seat removed (page 24-127)

REMOVE

1. Remove two cotter pins (1) from headed pins (2). Discard cotter pins.
2. Remove two headed pins (2) and washers (3) from accelerator Pedal (4), pedal mount (5), and pedal link (6).

CLEAN, INSPECT, AND REPLACE

3. Check pins, pedal mount, and pedal link. Replace parts that are cracked or have worn pivot holes.

INSTALL

4. Connect accelerator pedal (4) to pedal mount (5) and pedal link (6) with headed pins (2) and washers (3).
5. Secure headed pins (2) with new cotter pins (1).

ADJUST

6. Start engine (see your 10). Adjust accelerator pedal, if needed (page 23-34).

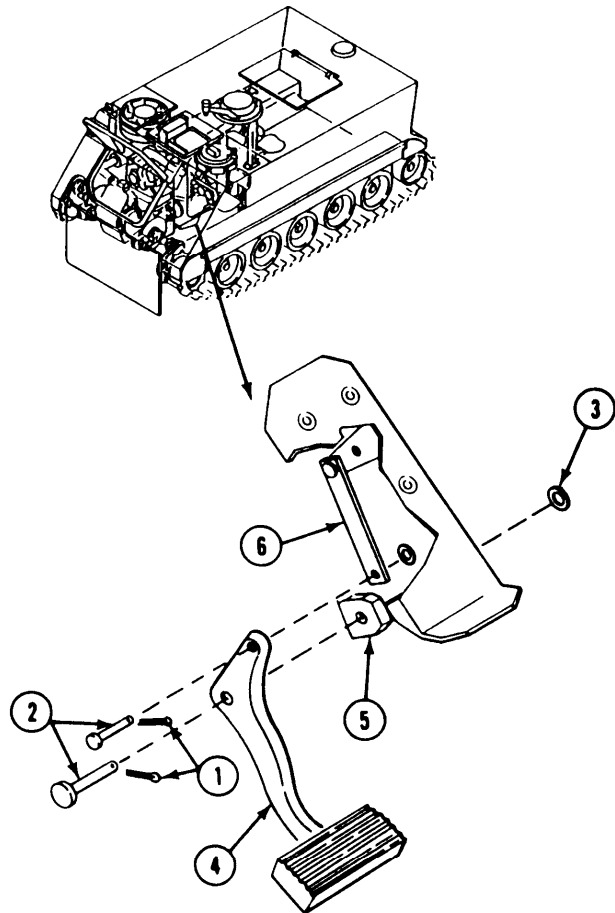

FOLLOW-THROUGH STEPS

1. Install driver's seat (page 24-127).
 2. Raise and lock ramp (see your -10).
 3. Stop/shutdown engine (see your -10).
-

END OF TASK

REPLACE UPPER ACCELERATOR PEDAL ASSEMBLY

DESCRIPTION

This task covers: Remove (page 23-23). Clean, Inspect, and Replace (page 23-24).
Install (page 3-24).

INITIAL SETUP

Tools:

General Mechanics Tool Kit (Item 30, App D)
Weighing Scale (Item 61, App D)

Materials/Parts:

Self-locking nut
Self-locking nut (2)

Personnel Required:

Unit Mechanic

References

See your -10

Equipment Conditions

Carrier blocked (see your -10)
Engine stopped/shutdown (see your -10)
Ramp lowered (see your -10)
Trim vane lowered and power plant front access door open (see your -10)
Driver's power plant access panel removed (page 24-25)
Driver's seat removed (page 24-127)
Remove lower accelerator pedal (page 23-22)

REMOVE

1. Disconnect return spring (1) from bellcrank (2).
2. Remove locknut (3), screw (4), and link (5) from bellcrank (2). Discard locknut.
3. Loosen nut (6). Remove bellcrank (2) and woodruff key (7) from pedal assembly (8).
4. Remove pedal (8) from guide (9).

CAUTION

Detent plunger and spring will fall out if detent block is turned over during removal

5. Remove two screws (10), locknuts (11), and pedal detent block (12) from pedal (8). Discard locknuts.
6. Remove two nuts (13) and set screws (14) from detent block (12). Then turn detent block (12) to allow two springs (15) and ball bearings (16) to slide out.
7. Remove plunger (17) and spring (18) from detent block (12).

8. Remove four screws (19) and remove guide (9) from power plant compartment.

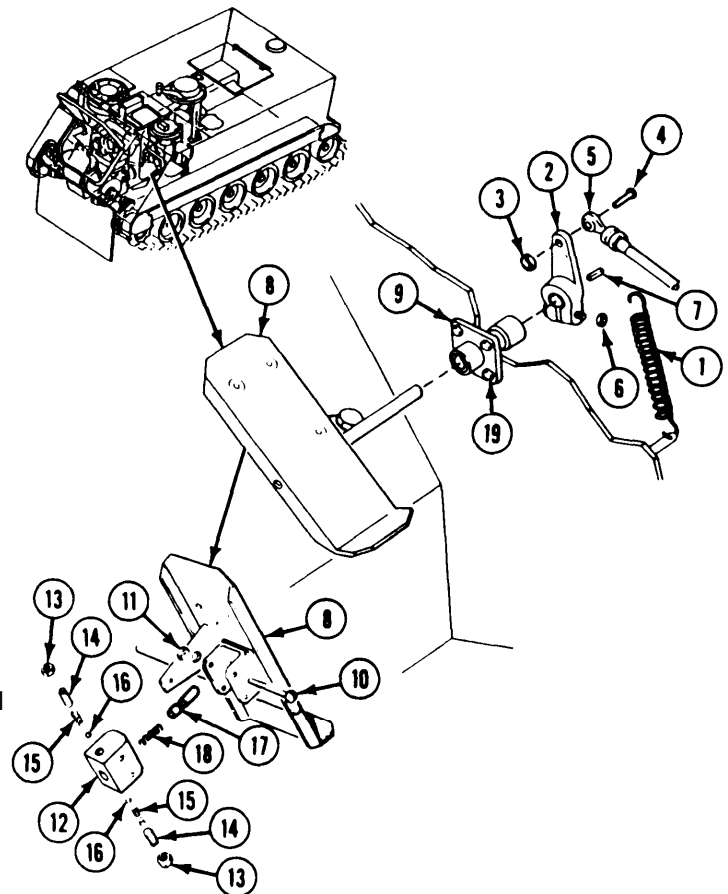

GO TO NEXT PAGE

CLEAN, INSPECT, AND REPLACE

9. Check pins, pedal mount, and pedal link.
Replace parts that are cracked or have worn pivot holes.

INSTALL

10. Install guide (1) on power plant compartment. Secure with four screws (2).
11. Install two ball bearings (3) and springs (4) in pedal detent block (5). Secure with two set screws (6).
12. Install two nuts (7) on two set screws (6).
13. Install plunger (8) and spring (9) in pedal detent block (5).
14. Install pedal detent block (5) on pedal (10). Secure with two screws (11) and new locknuts (12).
15. Use spring scale to adjust detent plunger (page 23-34. Use pressure to 35-40 pounds (16-18 kg).
16. Install pedal assembly (10) in guide (I).

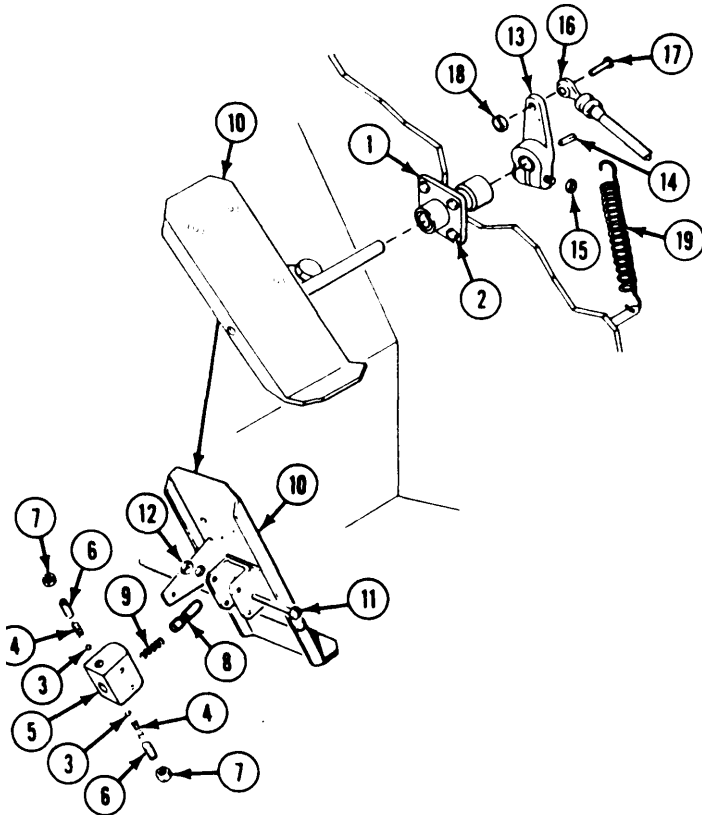

17. Place bellcrank (13) and woodruff key (14) on pedal assembly (10) shaft. Tighten nut (15).
18. Install link (16) on bellcrank (13). Secure with screw (17) and new locknut (18).
19. Connect return spring (19) to bellcrank (13).

FOLLOW-THROUGH STEPS

1. Install lower accelerator pedal (page 23-22).
2. Install driver's power plant access panel (page 24-25).
3. Install driver's seat (page 24-127).
4. Close power plant front access door and raise trim vane (see your -10).
5. Raise and lock ramp (see your -10).
6. Start engine (see your -10).
7. Check that upper accelerator pedal operates properly.
8. Stop/shutdown engine.

END OF TASK

REPLACE TRANSMISSION AND LOWER ACCELERATOR LINKAGE

DESCRIPTION

This task covers: Remove (page 23-25). Clean, Inspect, And Replace (page 23-26)
Install (page 23-27).

INITIAL SETUP

Tools:

General Mechanics Tool Kit (Item 30, App D)

Materials/Parts:

Grease (Item 18, App C)
Self-locking nut (7)
Key washer (2)

Personnel Required:

Unit Mechanic
Helper (H)

References:

see your -lo

Equipment Conditions:

Engine stopped/shutdown (see your -10)
Carrier blocked (see your -10)
Trim vane lowered and power plant front access door open (see your -10)
Driver's power plant access panel removed (page 24-25)
Hull bottom access cover removed (page 24-32)
Air control valve removed (page 7-11)
Air cleaner housing and element removed (page 7-7)

REMOVE

1. Rotate transmission drive shaft (1) so mounting flanges are in vertical position.
2. Disconnect three wiring harness connectors (2) at driver's compartment bulkhead.
3. Remove two screws (3), clamps (4), and wiring harness (5) from transmission cross-shaft bracket (6).

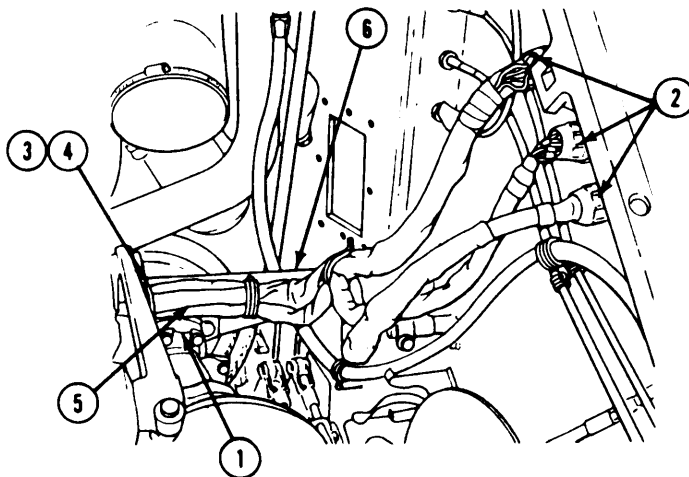

4. Remove locknut (7) and screw (8). Disconnect accelerator link (9) from accelerator cross-shaft bracket (10). Discard locknut.

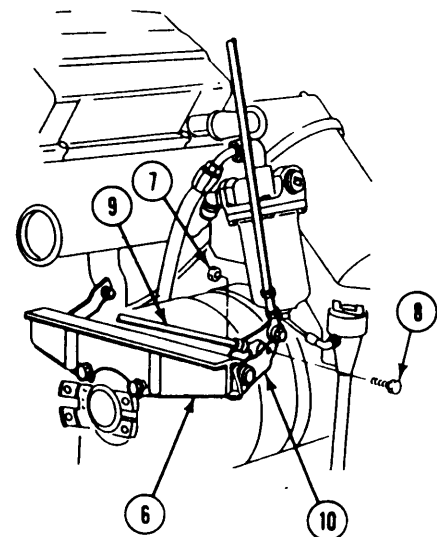

GO TO NEXT PAGE

5. Remove locknut (1) and screw (2). Disconnect transmission range selector to cross-shaft link (3) from transmission arm (4). Discard locknut.
6. Remove locknut (5) and screw (6). Disconnect throttle valve link (7) from throttle valve lever (8). Discard locknut.
7. Remove locknut (9) and screw (10). Disconnect range selector link (11) from range selector lever (12). Discard locknut.
8. Remove locknut (13) and screw (14). Remove throttle valve lever (8) from transmission shaft (15). Discard locknut.
9. Remove locknut (16) and screw (17). Remove range selector lever (12) from transmission shaft (18). Discard locknut.

10. Remove locknut (19) and screw (20). Disconnect throttle link (21) from vertical transfer shaft (22). Discard locknut.
11. Remove two screws (23), key washers (24, transmission cross-shaft bracket (25), accelerator cross-shaft (4), bellcrank (26), two transmission links (7 and 11), and throttle link (21) from carrier. Discard key washers.

CLEAN, INSPECT AND REPLACE

12. Check links, shafts, and brackets for wear and damage. Replace if needed.

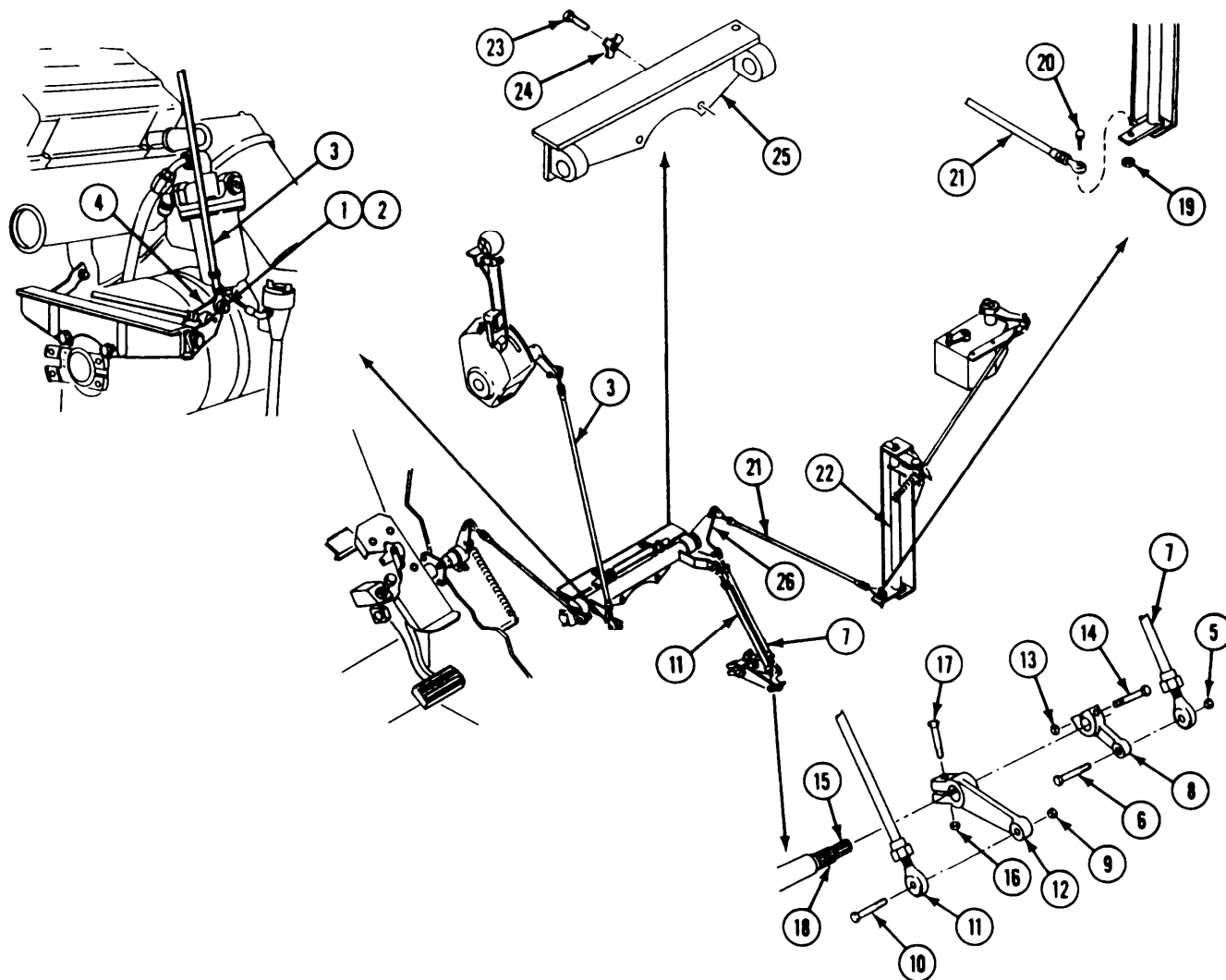

INSTALL

NOTE

Lubricate connecting link rod-end bearings before installation. Use GAA grease.

13. Place transmission cross-shaft bracket (1), accelerator cross-shaft (2), transmission cross-shaft (3), bellcrank (4), two transmission arm links (5 and 6), and throttle link (7) on transmission as a unit. Secure with two screws (8) and two new key washers (9).
14. Install throttle link (7) on vertical transfer shaft (10). Secure with screw (11) and new locknut (12).
15. Install range selector lever (13) on transmission shaft (14) with off-set side of lever toward transmission and clamp-screw hole aligned with flat on shaft. Secure with screw (15) and new locknut (16).
16. Install throttle valve lever (17) on transmission shaft (18) with off-set side of lever away from transmission and clamp-screw hole aligned with flat on shaft. Secure with screw (19) and new locknut (20).
17. Install range selector link (6) on transmission arm (13). Secure with screw (21) and new locknut (22).
18. Install throttle valve link (5) on transmission arm (17). Secure with screw (23) and new locknut (24).
19. Install transmission range selector to cross-shaft link (25) on transmission arm (3). Secure with screw (26) and new locknut (27).
20. Install accelerator link (28) on accelerator cross-shaft arm (2). Secure with screw (29) and new locknut (30).

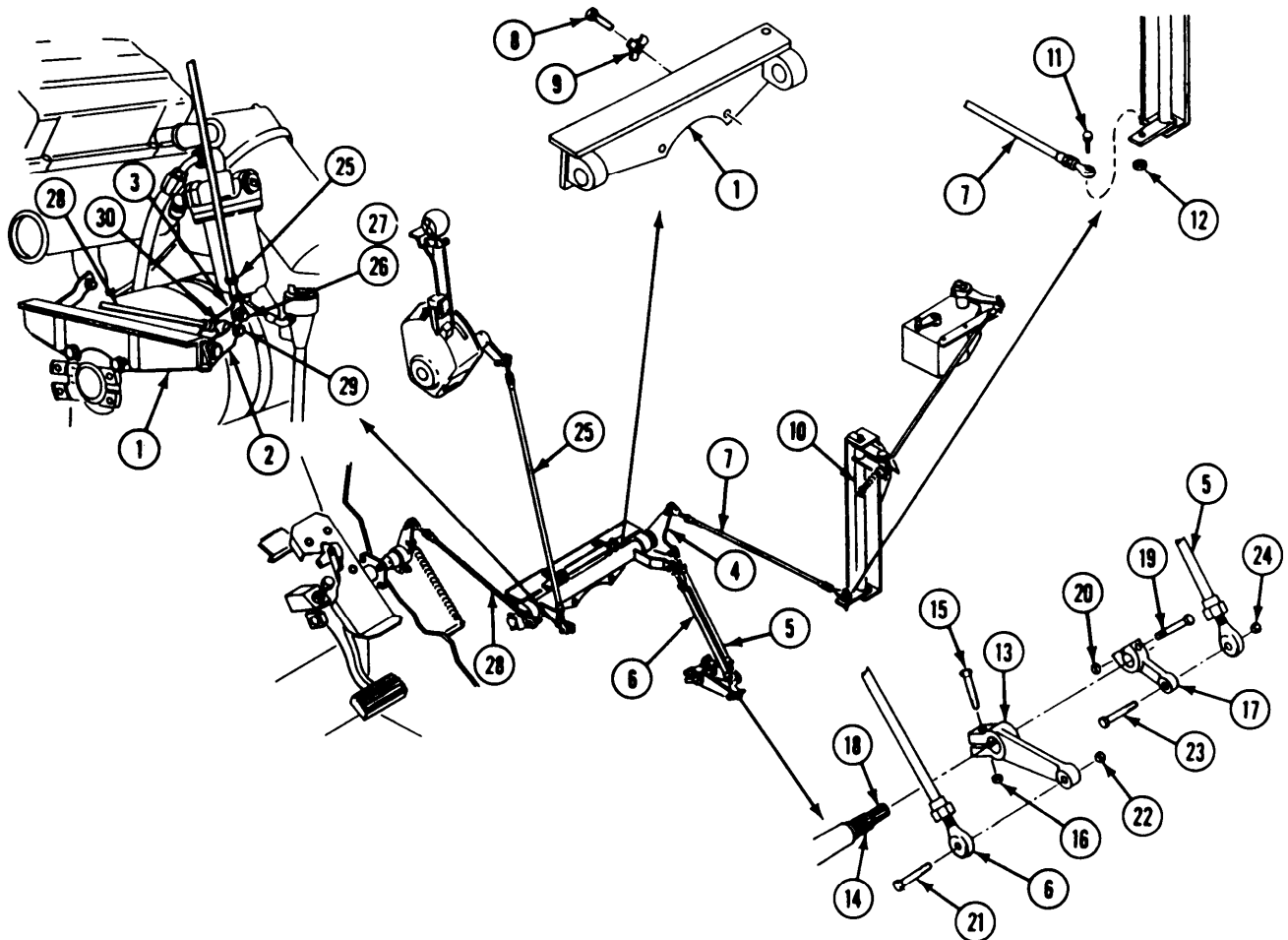

GO TO NEXT PAGE

21. Connect three wiring harness connectors (1) to receptacles on driver's compartment bulk-head.
22. Install wiring harness (2) on transmission cross-shaft bracket (3). Secure with two clamps (4) and screws (5).

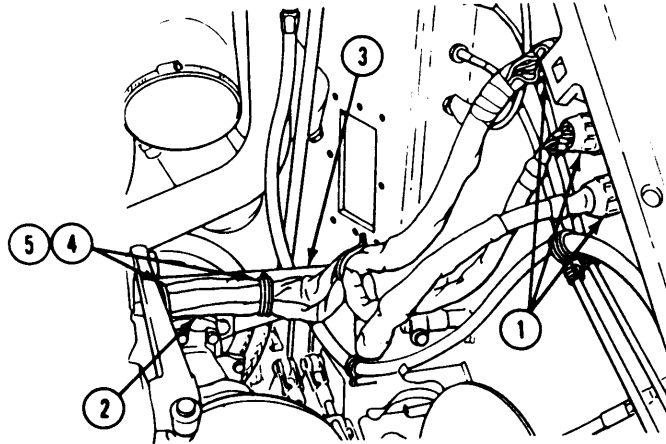

FOLLOW-THROUGH STEPS

- | | |
|--|---|
| 1. Adjust transmission cross-shaft linkage (page 23-34). | Install driver's power plant access panel (page 24-25). |
| 2. Install hull bottom access cover (page 24-32). | 6. Close power plant tint access door and raise trim vane (see your -10). |
| 3. Install air control valve (page 7-11). | 7. Operate carrier (see your -10). Check that transmission cross-shaft linkage operates properly. |
| 4. Install air cleaner housing and element (page 7-7). | |

END OF TASK

REPAIR TRANSMISSION AND LOWER ACCELERATOR LINKAGE

DESCRIPTION

This task covers: Remove (page 23-29). Clean, Inspect, and Replace (page 23-30).
Install (page 23-30).

INITIAL SETUP

Tools:

General Mechanics Tool Kit (Item 30, App D)

Materials/Parts:

Grease (Item 18, App C)

Self-locking nut (4)

Personnel Required:

Unit Mechanic

References:

See your -10

See your LO

Equipment Conditions:

Transmission and lower accelerator linkage removed (page 23-25)

REMOVE

1. Remove locknut (1), screw (2), and throttle link (3) from bellcrank (4). Discard locknut.
2. Remove locknut (5), screw (6), and throttle valve link (7) from bellcrank (4). Discard locknut.
3. Remove locknut (8), screw (9), and transmission shifting link (10) from transmission cross-shaft (11). Discard locknut.
4. Remove locknut (12), screw (13), and bellcrank (4) from accelerator cross-shaft (14). Discard locknut.
5. Remove woodruff key (15) from accelerator cross-shaft (14).
6. Remove accelerator cross-shaft (14) from transmission cross-shaft (11).
7. Separate transmission cross-shaft (11) from transmission cross-shaft bracket (16).

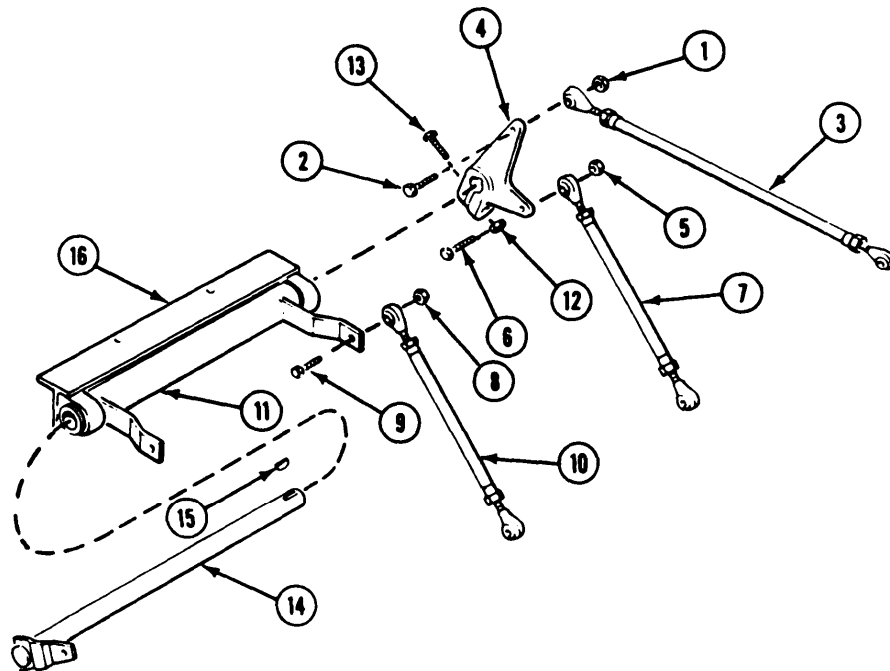

GO TO NEXT PAGE

CLEAN, INSPECT, AND REPLACE

8. Check links, shafts, and brackets for wear and damage. Replace if needed.

INSTALL

NOTE

Lubricate connecting link rod-end bearings before installation. Use GAA grease.

9. Install transmission cross-shaft (1) in transmission cross-shaft bracket (2).
10. Install accelerator cross-shaft (3) in transmission cross-shaft (1).
11. Install woodruff key (4) in accelerator cross-shaft (3).

12. Install bellcrank (5) on accelerator cross-shaft (3). Secure with screw (6) and new locknut (7).

13. Install transmission shifting link (8) on transmission cross-shaft (1). Secure with screw (9) and new locknut (10).

14. Install throttle valve link (11) on bellcrank (5). Secure with screw (12) and new locknut (13).

15. Install throttle link (14) on bellcrank (5). Secure with screw (15) and new locknut (16).

NOTE

If any links were replaced or link ends turned, then adjust linkage (see page 23-34).

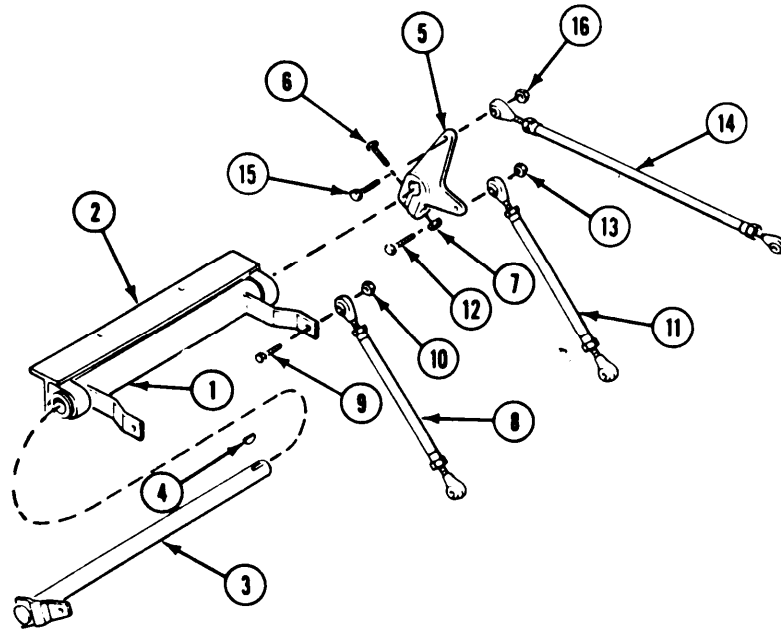

FOLLOW-THROUGH STEPS

1. Install transmission and lower accelerator linkage (page 23-25).

END OF TASK

REPLACE UPPER ACCELERATOR LINKAGE

DESCRIPTION

This task covers: Remove (page 23-31). Install (page 23-32).

INITIAL SETUP

Tools:

- General Mechanics Tool Kit (Item 30, App D)
- Screwdriver Set (Item 63, App D)
- Socket Wrench Set (Item 89, App D)
- Torque Wrench (Item 95, App D)

Materials/Parts:

- Antiseize compound (Item 8, App C)
- Grease (Item 18, App C)
- Cotter pin (2)
- Lockwasher (3)
- Self-locking nut (3)

Personnel Required:

Unit Mechanic

References:

- See your -10
- See your LO

Equipment Conditions:

- Engine stopped/shutdown (see your -10)
- Carrier blocked (see your -10)
- Ramp lowered (see your -10)
- Power plant rear access panel removed (page 24-27 or 24-29)

REMOVE

1. Remove locknut (1) and screw (2). Disconnect throttle link (3) from governor throttle arm (4). Discard locknut.
2. Loosen screw (5). Remove governor throttle arm (4) from governor (6).
3. Remove cotter pin (7), washer (8), spring (9), and throttle link (3) from pin (10). Discard cotter pin.
4. Remove locknut (11) and screw (12). Disconnect throttle link (13) from bracket assembly (14). Discard locknut.

5. Disconnect fuel hose (15) from tee (16).

6. Remove nut (17) and washer (18) that secure tee (16) to bracket assembly 04.

7. Remove cotter pin (19), washer (20) and pin (10) from bracket assembly (14). Discard cotter pin.

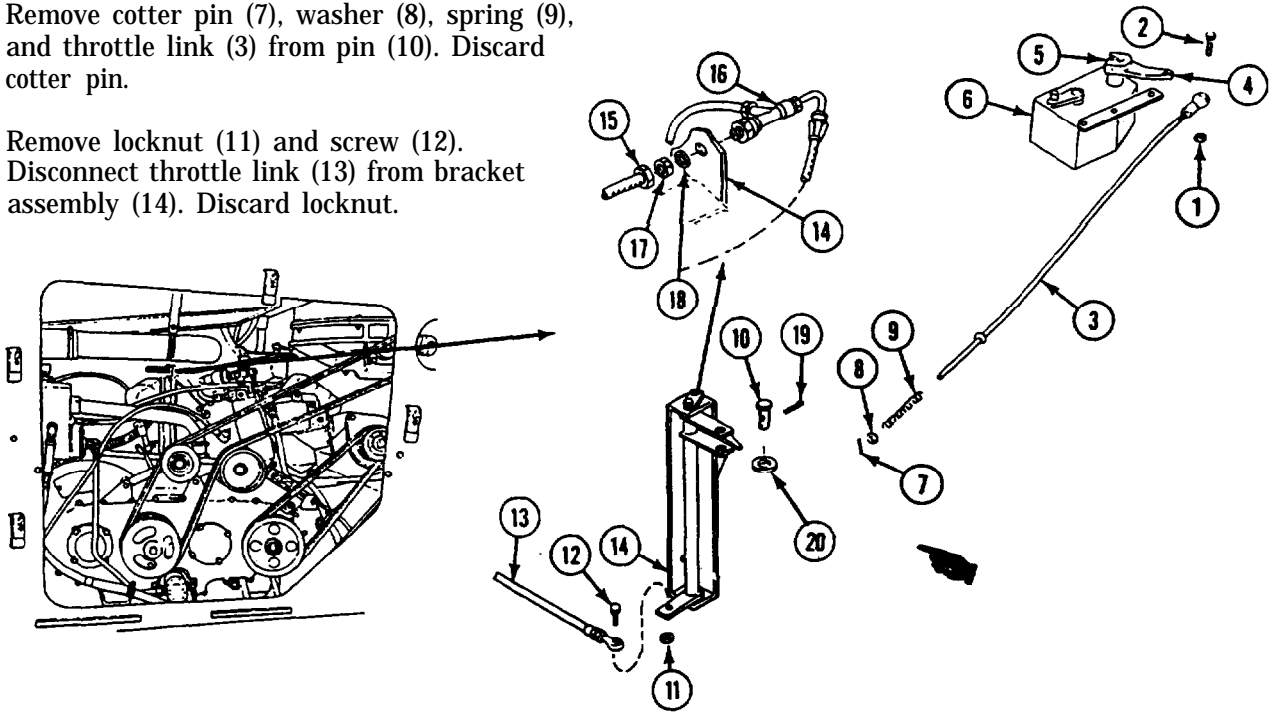

GO TO NEXT PAGE

8. Remove locknut (1) and screw (2) from bracket assembly (3). Use cross-tip screwdriver. Discard locknut.
9. Before removing screw (4), raise inner transfer shaft (5) high enough to tilt the outer transfer shaft (6).
10. Remove screw (4) and lockwasher (7) from bracket assembly (3). Discard lockwasher.
11. Remove two screws (8), lockwashers (9), nuts (10), and bracket assembly (3) from power plant. Discard lockwasher.

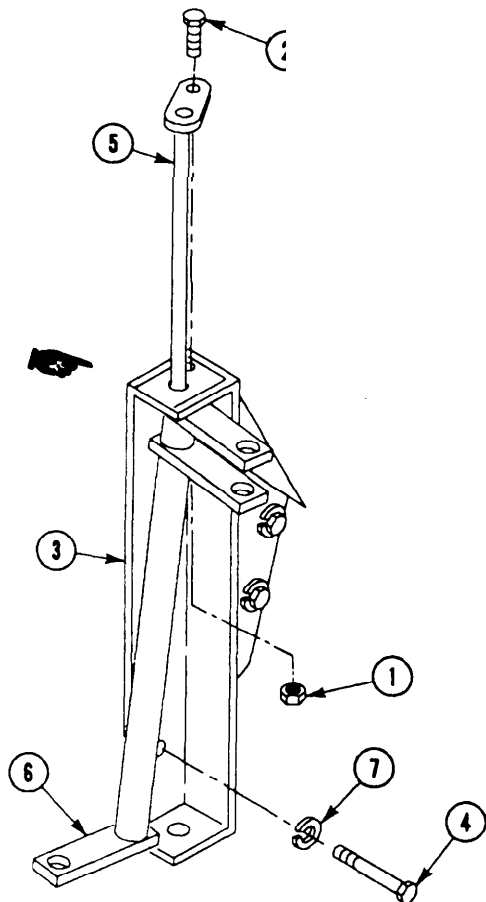

INSTALL

NOTE

Lubricate rod end bearings before assembling. Use GAA grease (see your LO).

13. Install bracket assembly (3) on power plant. Secure with two screws (8), new lockwashers (9), and nuts (10). Tighten screws to 300-324 lb-in (34-37 N·m) torque. Use torque wrench and socket wrench set.
14. Install screw (4), and new lockwasher (7) in bottom hole of bracket assembly (3). Tighten screw to 264-288 lb-in (30-33 N·m) torque. Use torque wrench and socket wrench set.
15. Position inner transfer shaft (5) and outer transfer shaft (6) in bracket assembly (3). Secure with screw (2) and new locknut (1). Use crosstip screwdriver.

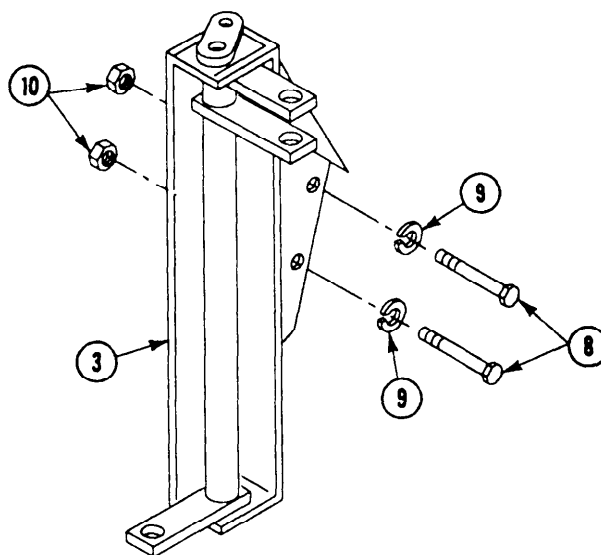

16. Install pin (1), washer (1.1) on bracket assembly (2). Secure with new cotter pin (3).
17. Install tee (4) on bracket assembly (2). Secure with nut (5) and washer (6).
18. Connect fuel line (7) to tee (4).
19. Install throttle link (8) on bracket assembly (2). Secure with new locknut (9) and screw (10).
20. Install spring (11) and washer (12) on throttle link (13). Insert throttle link through pin (1) and secure with new cotter pin (14).
21. Install governor throttle arm (15) on governor (16). Tighten screw (17).
22. Install throttle link (13) on governor throttle arm (15). Secure with screw (18) and new locknut (19).
23. Adjust accelerator and transmission throttle valve linkage (page 23-34).

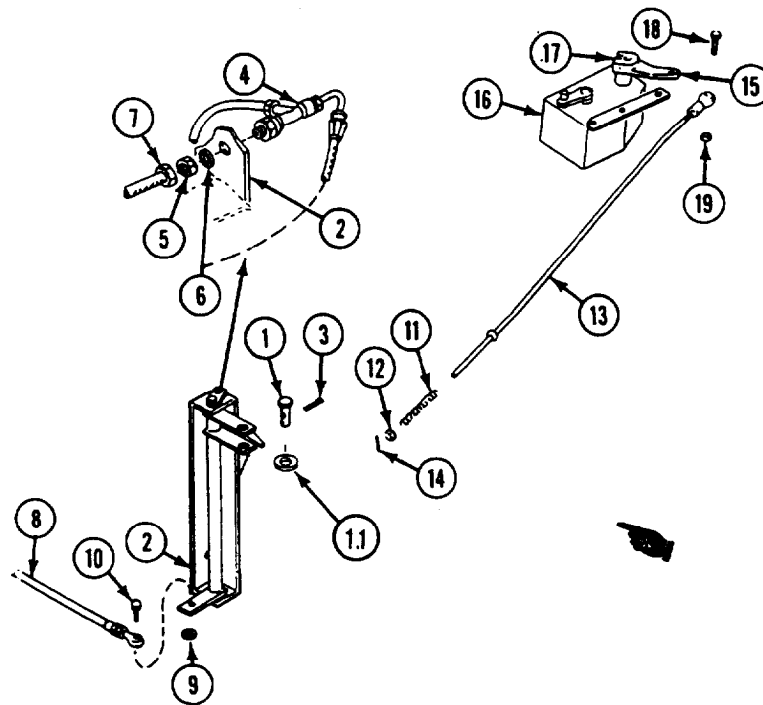

FOLLOW-THROUGH STEPS

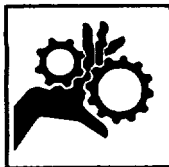

WARNING
Loose clothing is dangerous around moving belts and pulleys. You could get injured if your clothes get caught in moving parts.

1. Start engine (see your -10). Check that upper accelerator linkage operates properly. Stop/shutdown engine (see your -10).
2. Install power plant rear access panel (page 24-27 or 24-29).
3. Raise and lock ramp (see your -10).
4. Stop/shutdown engine (see your -10).

END OF TASK

REPAIR UPPER ACCELERATOR LINKAGE

INITIAL SETUP

Tools:

General Mechanics Tool Kit (Item 30, App D)

Personnel Required:

Unit Mechanic

Materials/Parts:

Grease (Item 18, App C)
Self-locking nut

Equipment Conditions

Engine stopped/shutdown (see your -10)
Upper accelerator linkage removed from
earner (page 23-31)

REMOVE

1. Remove locknut (1), screw (2), and inner transfer shaft (3) from outer transfer shaft (4). Discard locknut.
2. Remove outer transfer shaft (4) from transfer shaft bracket (5).

CLEAN, INSPECT, AND REPLACE

3. Check links, shafts, and brackets for wear and damage. Replace if needed.

INSTALL

NOTE

Lubricate bearing surfaces of shafts before assembly. Use GAA grease.

4. Place outer transfer shaft (4) in transfer shaft bracket (5).
5. Insert inner transfer shaft (3) into outer transfer shaft (4).
6. Secure shaft (3) to bracket (5) with screw (2) and new locknut (1).

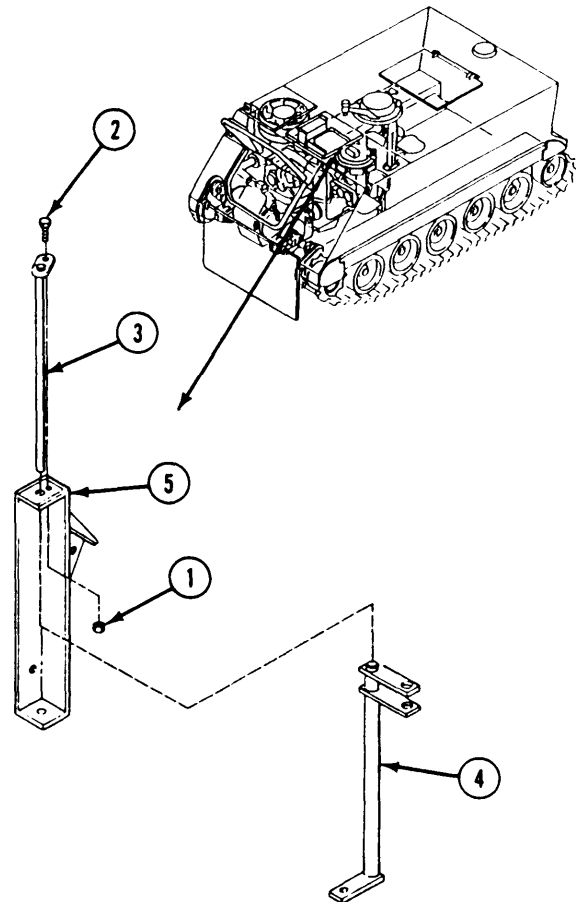

FOLLOW-THROUGH STEPS

1. Install upper accelerator linkage (page 23-31).
-

END OF TASK

ADJUST ACCELERATOR AND TRANSMISSION THROTTLE VALVE LINKAGE

DESCRIPTION

This task covers: Adjust Governor Linkage (page 23-34).
 Adjust Throttle Valve Linkage (page 23-35).
 Adjust Idle Stop (page 23-37).
 Adjust Upper Accelerator Pedal Detent Stop (page 23-38).
 Adjust Upper Accelerator Pedal Toe Stop (page 23-39).
 Adjust Upper Accelerator Detent Plunger (page 23-40).
 Check operation (page 23-40).

INITIAL SETUP

Tools:

General Mechanics Tool Kit (Item 30, App D)
 Weighing Scale (Item 61, App D)

Personnel Required:

Unit Mechanic

References:

See your -10

Equipment Conditions:

Engine stopped/shutdown (see your -10)
 Carrier blocked (see your -10)
 Ramp lowered (see your -10)
 Trim vane lowered and power plant front access door open (see your -10)
 Driver's power plant access panel removed (page 24-25)
 Power plant rear access panel removed (page 24-27 or 24-29)

ADJUST GOVERNOR LINKAGE

NOTE

Before accelerator and governor throttle arm linkage adjustments can be made, engine governor idle speed must be correct. Start engine (see your -10). Check idle speed on tachometer. If engine does not idle within range of 650-700 rpm, notify your supervisor to have the engine governor idle speed and engine no-load speed set.

1. Remove screw (1), locknut (2), and throttle link (3) from governor throttle arm (4).
2. Remove two screws (5) and gage (6) from governor (7).

NOTE

Gage (6) is identified as part number 12269180 (NSN 5340-01-086-3243).

3. Install gage (6) in adjustment position on governor (7). Secure with two screws (5).

4. Loosen screw (8) that secures governor throttle arm (4) to governor shaft (9).

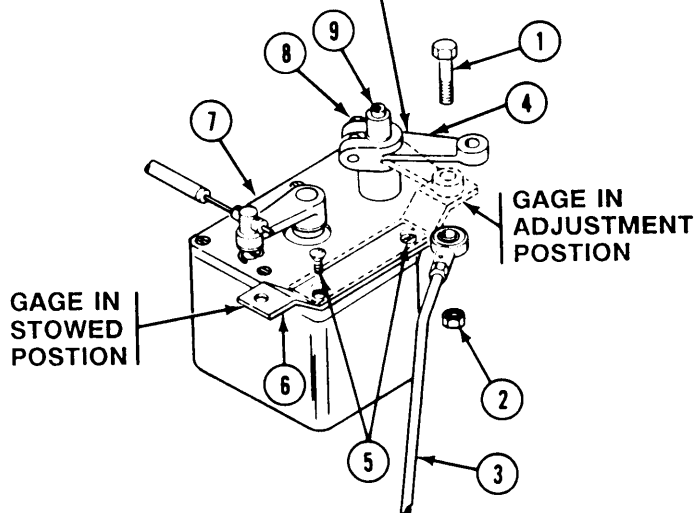
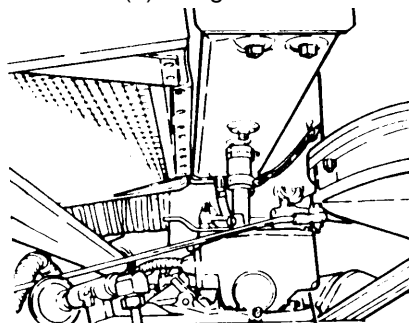

5. Align hole in governor throttle arm (1) with hole in gage (2). Insert screw (3) through throttle arm and gage.
6. Insert 3/16 inch (5 mm) key socket head screw in plug on top of governor shaft (4). Turn to the right to rotate governor shaft (4) to full throttle positional hold.
7. Tighten screw (5) that secures throttle arm (1) to governor shaft (4).
8. Remove screw (3) installed in step 5, above.
9. Remove two screws (6) that secure gage (2) to governor (7) and return gage to stowed position. Secure gage with two screws (6).
10. Connect throttle link (7) to governor throttle arm (1). Secure with screw (3) and nut (8).

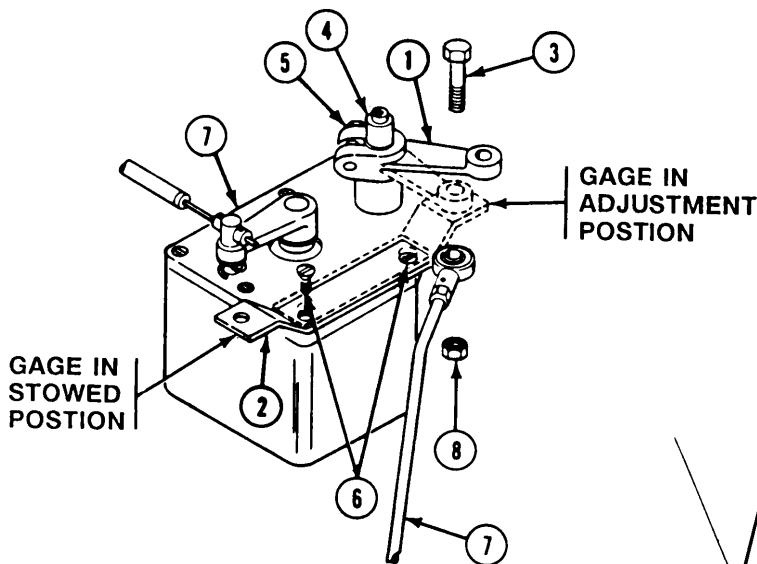

NOTE

On M741A1 carrier, the clearance between screw (3) and lockout solenoid must be checked at this point (page 28-74).

11. Adjust throttle valve linkage.

ADJUST THROTTLE VALVE LINKAGE

12. Turn screw (9) into floor bracket (10) to allow free movement of accelerator pedal (11).

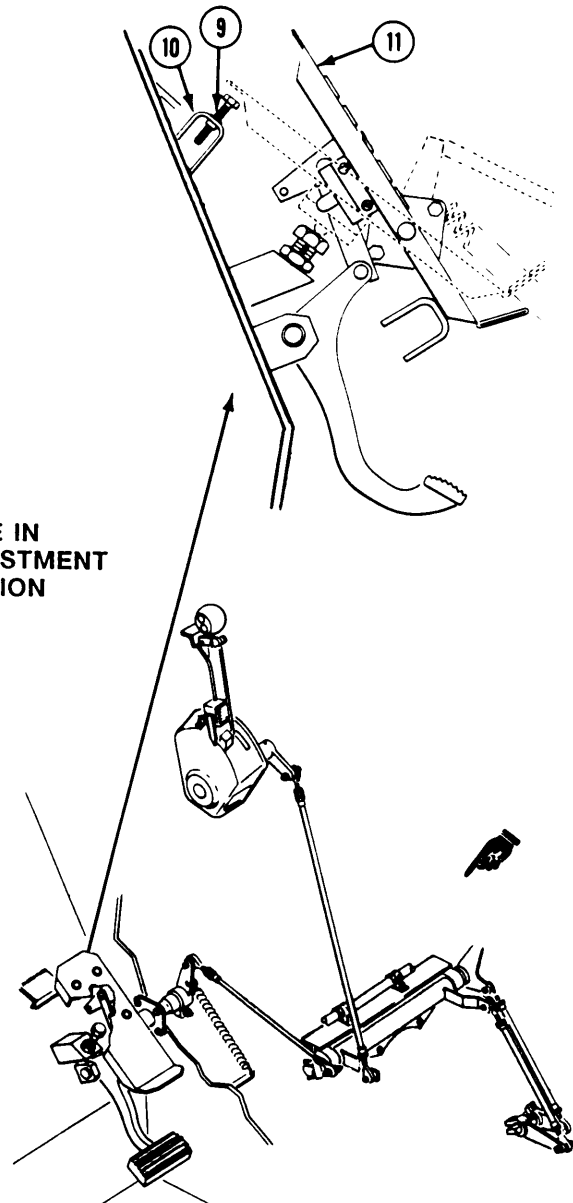

GO TO NEXT PAGE

13. Loosen locknut (1). Turn detent stop screw (2) in to allow free movement of accelerator pedal (3).
14. Loosen locknut (4). Remove screw (5), nut (6), and throttle link (7) from outer transfer shaft (8).
15. Loosen locknut (9). Remove screw (10), nut (11), and accelerator pedal link (12) from bellcrank (13).
16. Place governor throttle arm (14) and bellcrank (15) in full throttle position.
17. Align holes in throttle link (7) and outer transfer shaft (8) so screw (5) will pass through freely. Shorten throttle link (7) by turning bearing end (16) 11 turns to the right.
18. Install throttle link (7) on outer transfer shaft (8). Secure with screw (5) and nut (6). Tighten locknut (4) on link (7).
19. Adjust idle stop (page 23-37).

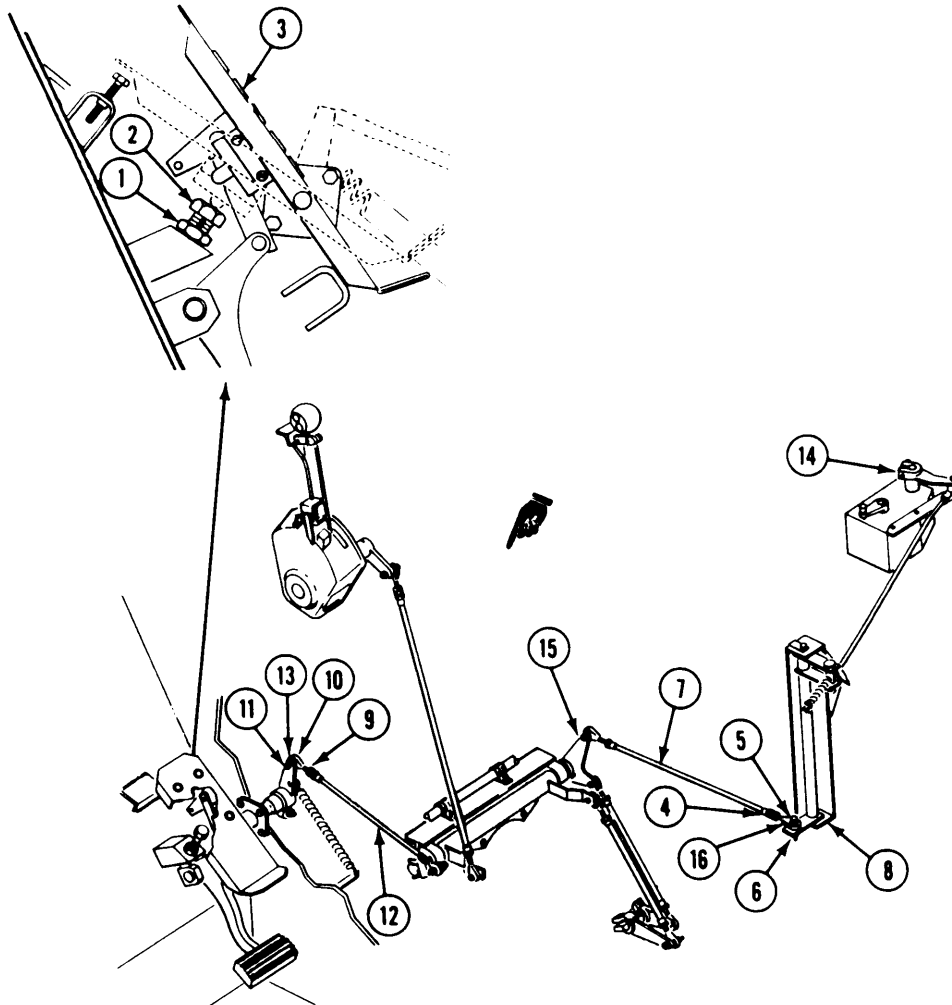

ADJUST IDLE STOP

20. Place throttle arm (1) at idle position and upper accelerator pedal (2) against heel stop.
21. Align holes in accelerator pedal link (3) and bellcrank (4) so screw (5) will pass through freely.
22. Lengthen accelerator pedal link (3) by turning bearing end (6) one turn to the left.
23. Install accelerator pedal link (3) on bellcrank (4). Secure with screw (5) and nut (7).
24. Tighten locknut (8) on accelerator pedal link (3).
25. Adjust upper accelerator pedal detent stop (page 23-38).

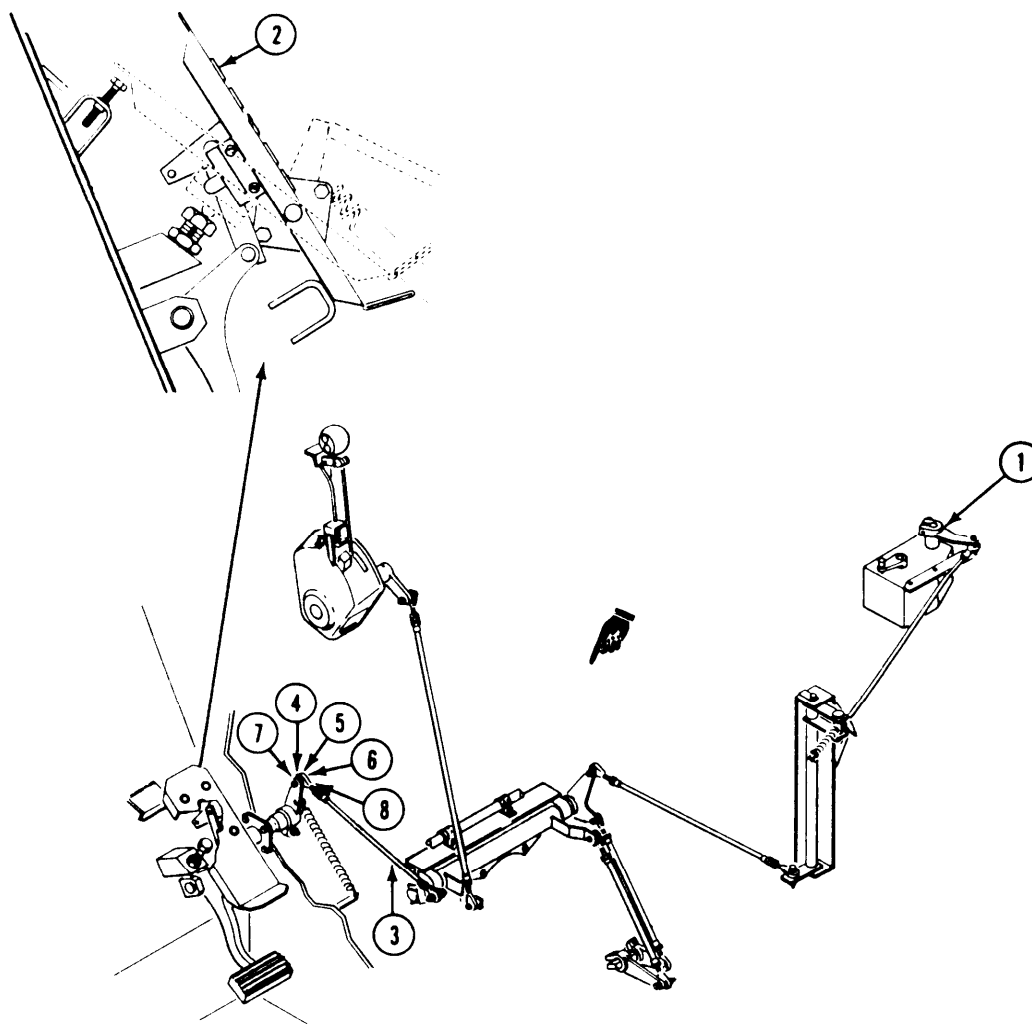

GO TO NEXT PAGE

ADJUST UPPER ACCELERATOR PEDAL DETENT STOP

26. Loosen locknut (1). Adjust stop screw (2) so detent plunger (3) will contact stop screw at full throttle position.

27. With pedal (4) in full throttle position, travel spring (5) should be compressed so a gap of 1/64 to 3/64 inch (0.4 to 1.0 mm) exists between pivot pin (6) and rod stop (7).

28. Adjust upper accelerator pedal toe stop (page 23-39).

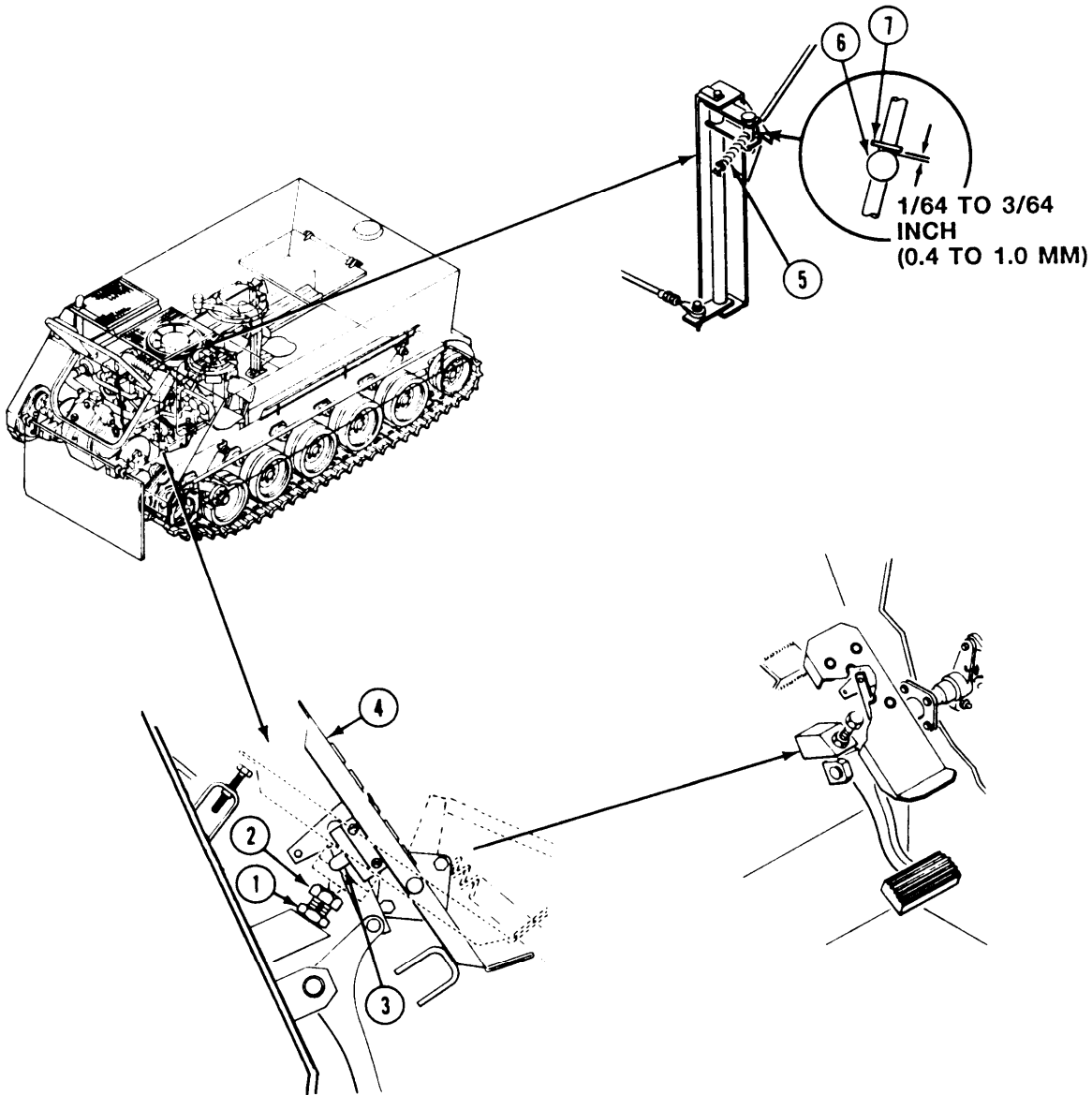

ADJUST UPPER ACCELERATOR PEDAL TOE STOP

29. Remove screw (1), nut (2), and throttle link (3) from outer transfer shaft (4).
30. Depress upper accelerator pedal (5) until transmission arm (6) is in full open position.
31. Adjust toe stop screw (7) in floor bracket (8) to 1/16 inch (2 mm) space between upper accelerator pedal (5) and screw.
32. Install throttle link (3) on outer transfer shaft (4). Secure with screw (1) and nut (2).
33. Adjust detent plunger if necessary (page 23-40).
34. Check operation of accelerator controls and transmission shift points (page 23-40).

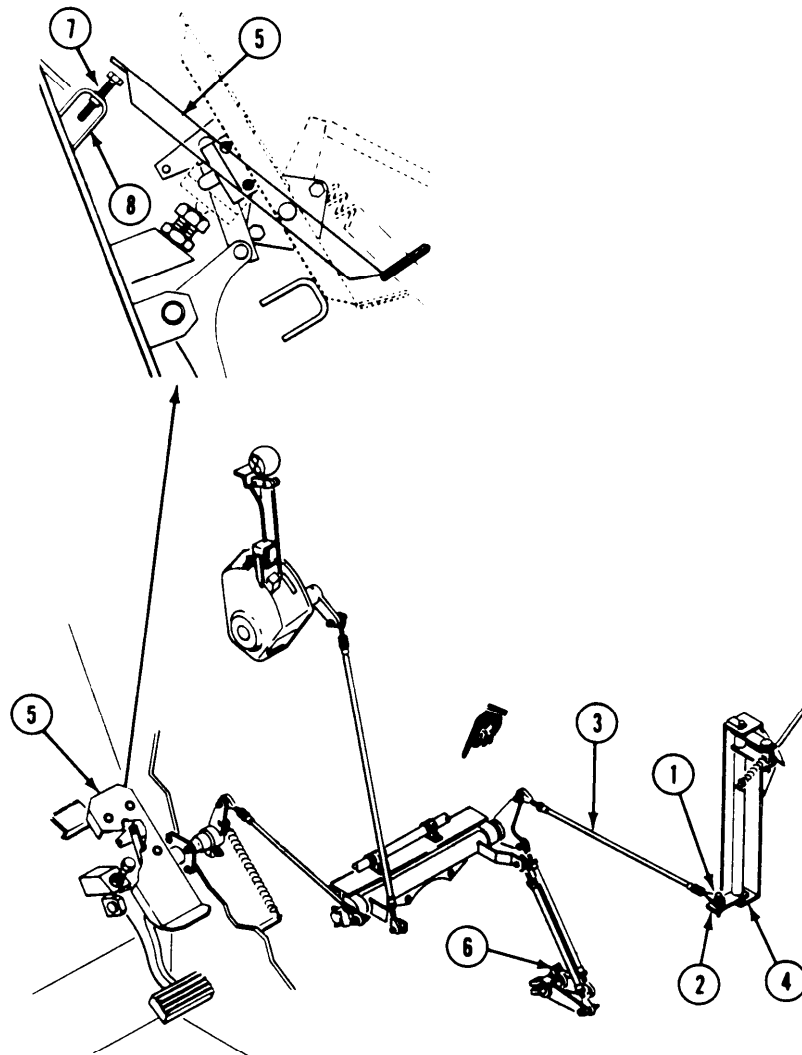

GO TO NEXT PAGE

ADJUST UPPER ACCELERATOR DETENT PLUNGER

NOTE

Detent plunger is factory lubricated and adjusted for a force of 35 to 40 pounds to push plunger through detent. If lubrication or repair is required, see **REPLACE UPPER ACCELERATOR PEDAL ASSEMBLY** procedure on page 23-23. If adjustment only is required, do the following steps.

35. Remove upper accelerator pedal (page 23-23).
36. Loosen two locknuts (1). Turn two set screws (2) in detent block (3) to right to increase spring pressure on plunger (4), or to left to decrease pressure. Use scale to test for 35 to 40 pounds (16 to 18 kg) force required to push plunger (4) through detent.
37. Install upper accelerator pedal (page 23-23).
38. Check operation of accelerator controls and transmission shift points (steps 39 through 49 below).

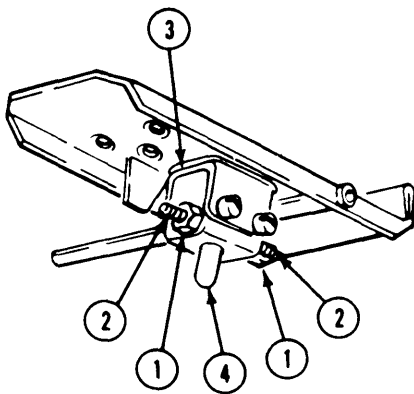

CHECK OPERATION

WARNING

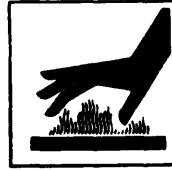

If you work on a carrier that has been running, you could be burned. All tasks begin with a cooled down carrier. Allow carrier to cool or use care if you work on a hot carrier.

39. Install power plant rear access panel (page 24-27 or 24-29).
40. Install driver's power plant access panel (page 24-25).
41. Close power plant front access door and raise trim vane (see your -10).
42. Raise and lock ramp (see your -10).
43. Operate carrier until engine and transmission are at normal operating temperatures (see your -10).
44. With transmission range selector in 1-3 or 2-3 range and foot pedal held at full throttle position (detent plunger contacting detent screw but not compressing detent plunger), upshift from second lockup to third converter should occur at engine speed of 2640 to 2800 rpm.
45. If engine speed is not within specified range, park carrier and stop engine.

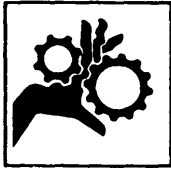

WARNING
Adjusting accelerator linkage while the engine is running can cause your arm to be badly injured. Do not adjust accelerator linkage with the engine

running.

46. Remove driver's and rear power access panels.
47. Loosen locknut (1). Remove screw (2) and nut (3) from throttle link (4) and transfer shaft (5). To decrease engine RPM at shift point, shorten throttle link (4) by turning rod end (6) to the right. To increase engine RPM at shift point, lengthen throttle link (4) by turning rod end (6) to the left. Attach throttle link (4) to transfer shaft (5) with screw (2) and nut (3). Tighten locknut (1).

48. Readjust accelerator pedal stops by repeating the following procedures:

Adjust Idle Stop (page 23-37).

Adjust Upper Accelerator Pedal Detent Stop (page 23-38).

Adjust Upper Accelerator Pedal Toe Stop (page 23-39).

49. Repeat Operational Check (page 23-40).

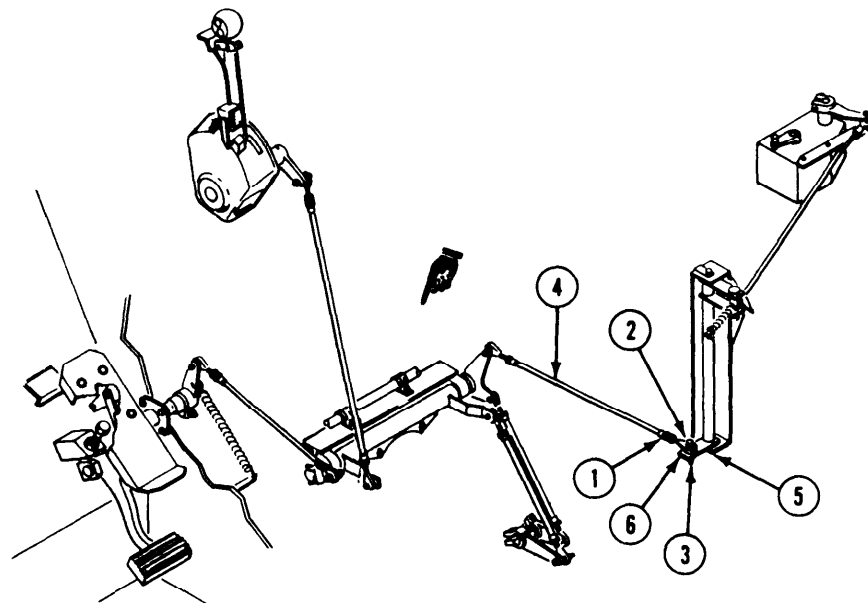

FOLLOW-THROUGH STEPS

1. Engine stopped/shutdown (see your -10).
-

END OF TASK

REPLACE HAND THROTTLE

DESCRIPTION

This task covers: Remove (page 23-42). Install (page 23-43). Adjust (page 23-43).

INITIAL SETUP

Tools:

General Mechanics Tool Kit (Item 30, App D)

References:

See your -10

Materials/Parts:

Cotter pin
Grommet
Lockwasher
Self-locking nut

Equipment Conditions:

Engine stopped/shutdown (see your -10)
Carrier blocked (see your -10)
Trim vane lowered (see your -10)
Power plant front access door opened (see your -10)
Driver's power plant access panel removed (see your -10)

Personnel Required:

Unit Mechanic

REMOVE

1. Remove two screws (1), washers (2), and four clamps (3) that secure throttle control cable assembly (4) to two weldnuts (5).
2. Remove two screws (6), one locknut (7), lockwasher (8), two straps (9), and cable assembly (4) from weldnut (10). Discard locknut and lockwasher.
3. Remove cotter pin (11) and washer (12). Disconnect pin (13) from accelerator pedal assembly (14). Discard cotter pin.
4. Loosen set screw (15). Remove collar (16) and pin (13) from cable assembly (4).
5. Pull cable assembly (4) through grommet (17) in driver's floor plate and out through power plant front access door opening. Discard grommet.
6. Remove nut (18) and washer (19) that secure cable assembly (4) to driver's compartment bulkhead.
7. Remove cable assembly (4) from driver's compartment

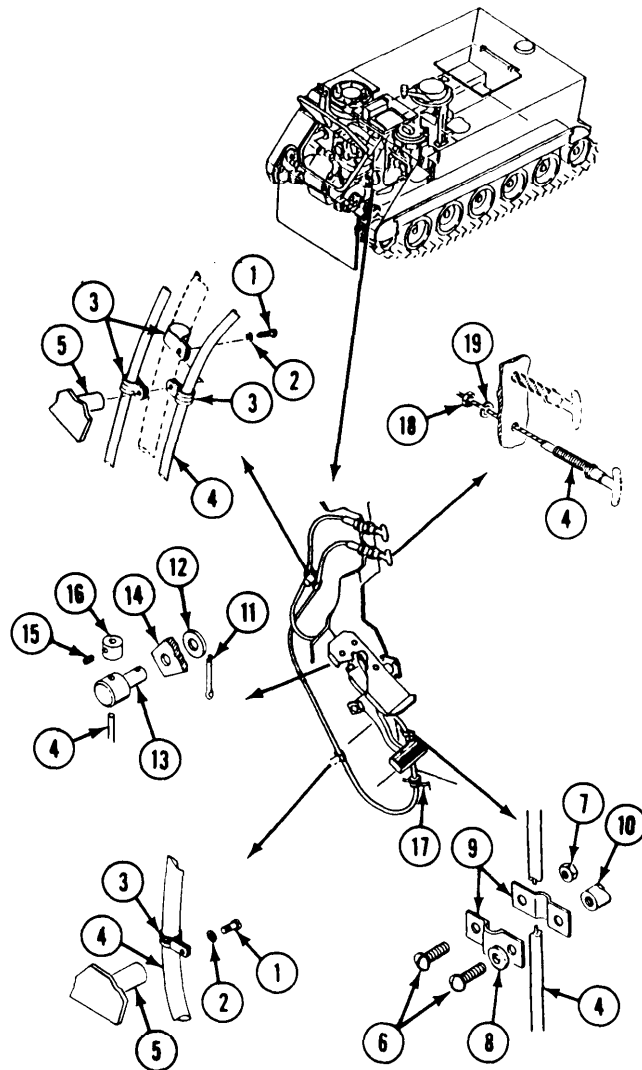

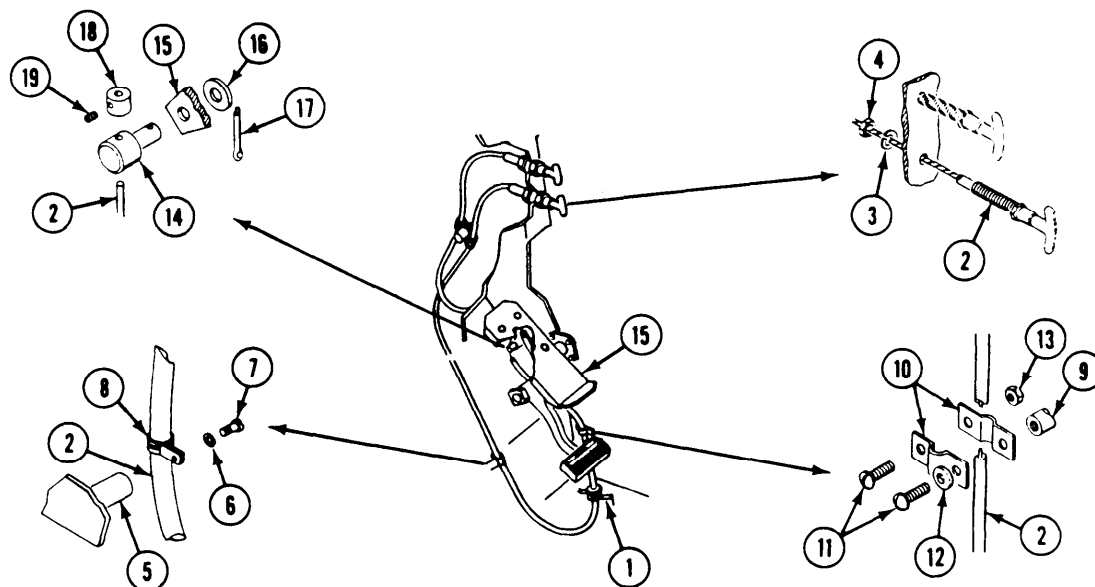

INSTALL

- 8. Install new grommet (1) in driver's floor plate.
- 9. Feed cable assembly (2) through mounting hole in driver's compartment bulkhead to power plant front access door opening.
- 10. Slide washer (3) and nut (4) on cable assembly (2). Secure to driver's compartment bulkhead.
- 11. Install cable assembly (2) on two weldnuts (5). Secure with two washers (6), screws (7), and four clamps (8).
- 12. Install cable assembly (2) on weldnut (9). Secure with two straps (10), screws (11), new lockwasher (12), and one new locknut (13).
- 13. Install pin (14) on accelerator pedal assembly (15). Secure with washer (16) and new cotter pin (17).
- 14. Install cable assembly (2) on pin (14). Secure with collar (18) and set screw (19).

ADJUST

- 15. Loosen set screw (19). Push control cable assembly (2) handle full forward.
- 16. Place pedal assembly (15) in full closed throttle position (see your -10). Tighten set screw (19) in collar (18).

FOLLOW-THROUGH STEPS

- 1. Start engine (see your -10). Using the pedal (15), check that hand throttle operates properly.
- 2. Stop/shutdown engine (see your -10).
- 3. Close power plant front access door (see your -10).
- 4. Raise trim vane (see your -10).
- 5. Install driver's power plant access panel (see your -10).

END OF TASK

REPLACE FUEL SHUTOFF CABLE

DESCRIPTION

This task covers: Remove (page 23-44). Install (page 23-45). Adjust (page 23-46).

INITIAL SETUP

Tools:

General Mechanics Tool Kit (Item 30, App D)

References:

See your -10

Materials/Parts:

Cotter pin
Self-locking nut (3)

Equipment Conditions:

Engine stopped/shutdown (see your -10)
Carrier blocked (see your -10)
Ramp lowered (see your -10)
Trim vane lowered and power plant front access door open (see your -10)
Power plant rear access panel removed (page 24-27) or (page 24-29)

Personnel Required:

Unit Mechanic

REMOVE

1. Remove locknut (1) and screw (2) from engine bracket (3). Discard locknut.
2. Remove locknut (4), screw (5), and clamp (6) from engine bracket (7). Discard locknut.
3. Remove locknut (8), screw (9), and clamp (10) from differential bracket (11). Discard locknut .
4. Remove three screws (12), washers (13), and clamps (14) from three weldnuts (15).
5. Loosen set screw (16). Remove front collar (17) from control assembly (18).
6. Remove cotter pin (19), washer (20), and pin (21) from fuel control arm (22). Discard cotter pin.

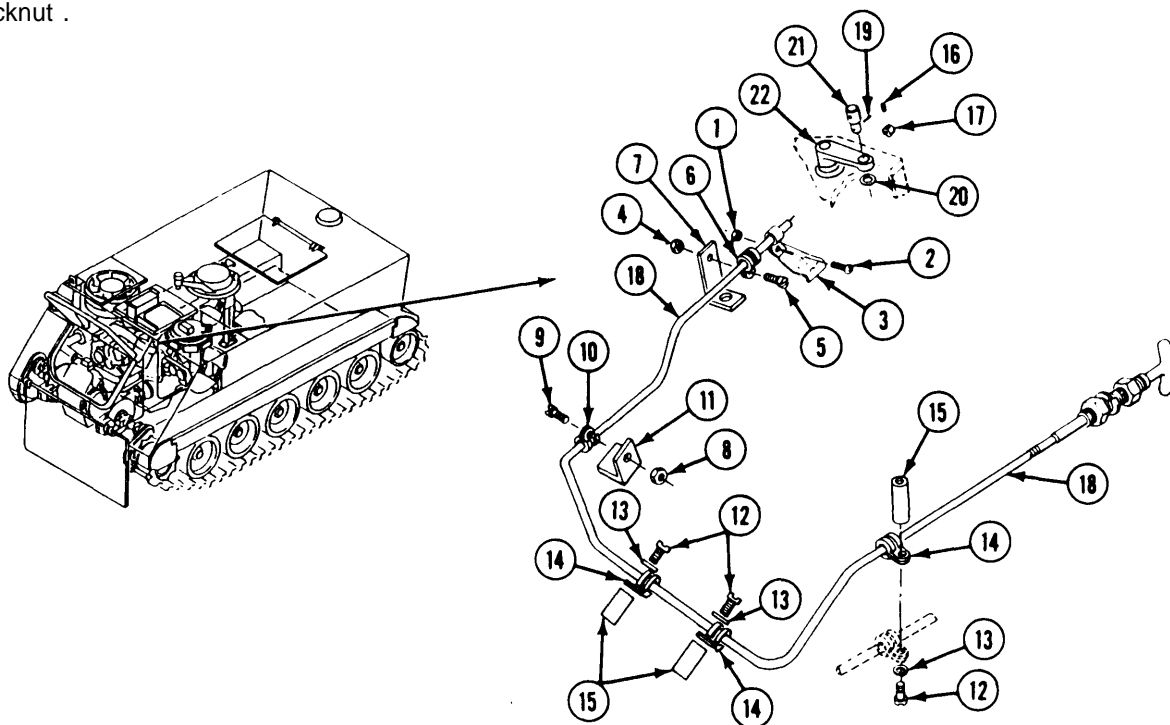

7. Loosen set screw (1). Remove rear collar (2) from control assembly (3).
8. Remove control assembly out of power plant compartment through power plant front access door.
9. Remove nut (4) and washer (5) from control assembly at driver's compartment bulkhead.
10. Remove control assembly from driver's compartment.

13. Install control assembly on three weldnuts (6). Secure with three clamps (7), washers (8) and screws (9).

CAUTION

Contact between the fuel shutoff cable and radiator coolant lines during operation of the engine may cause melting of the plastic case on the fuel shutoff cable.

14. Remove slack from fuel shutoff cable so that it does not touch the auxiliary radiator tube.
15. Install control assembly on differential bracket (10). Secure with clamp (11), screw (12), and new locknut (13).
16. Install pin (14) on fuel control arm (15). Secure with washer (16) and new cotter pin (17).

INSTALL

11. Feed control assembly through mounting hole in driver's compartment bulkhead to power plant front access door opening.
12. Slide washer (5) and nut (4) onto control assembly. Secure control assembly to driver's compartment bulkhead.

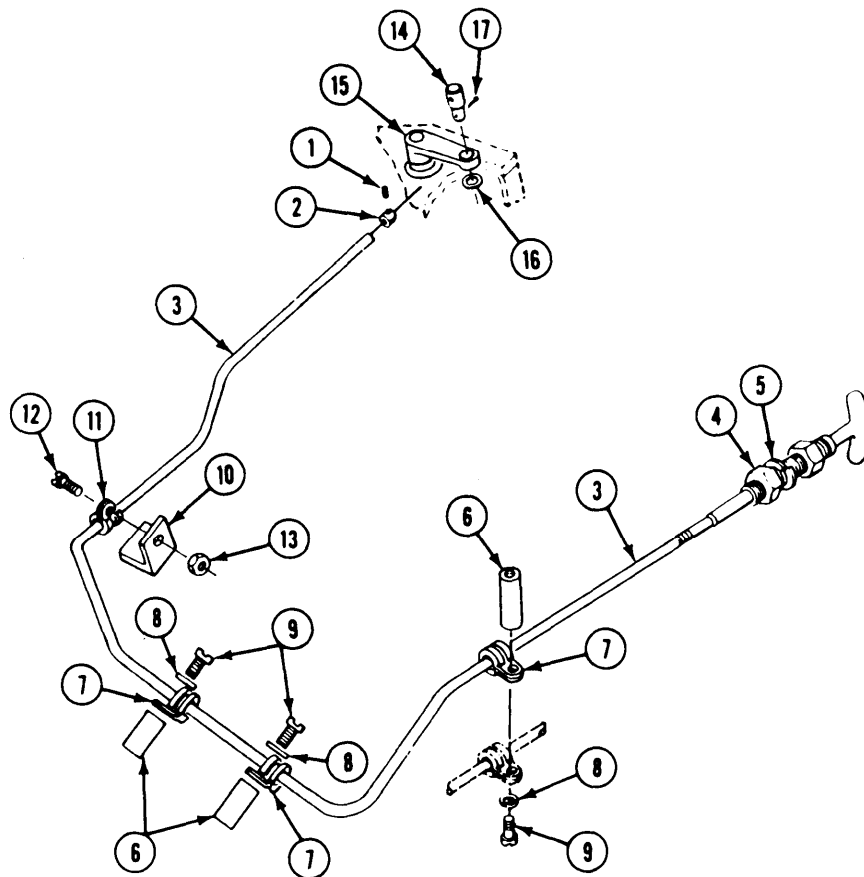

GO TO NEXT PAGE

17. Insert control assembly (1) through engine bracket (2).
18. Install rear collar (3) on control assembly (1).
19. Insert control assembly (1) through pin (4).
20. Install front collar (5) on control assembly (1).
21. Secure collars (3 and 5) on control assembly (1) with two set screws (6 and 7).
22. Install control assembly (1) on engine bracket (8). Secure with clamp (9), screw (10), and new locknut (11).
23. Install control assembly (1) on engine bracket (2). Secure with screw (12) and new locknut (13).

ADJUST

24. Loosen two set screws (6 and 7) in collars (3 and 5).
25. Pull control assembly handle (14) to full out position.
26. Rotate fuel control arm (15) to full clockwise position.
27. Place two collars (3 and 5) on each side of pin (4). Secure with two set screws (6 and 7).

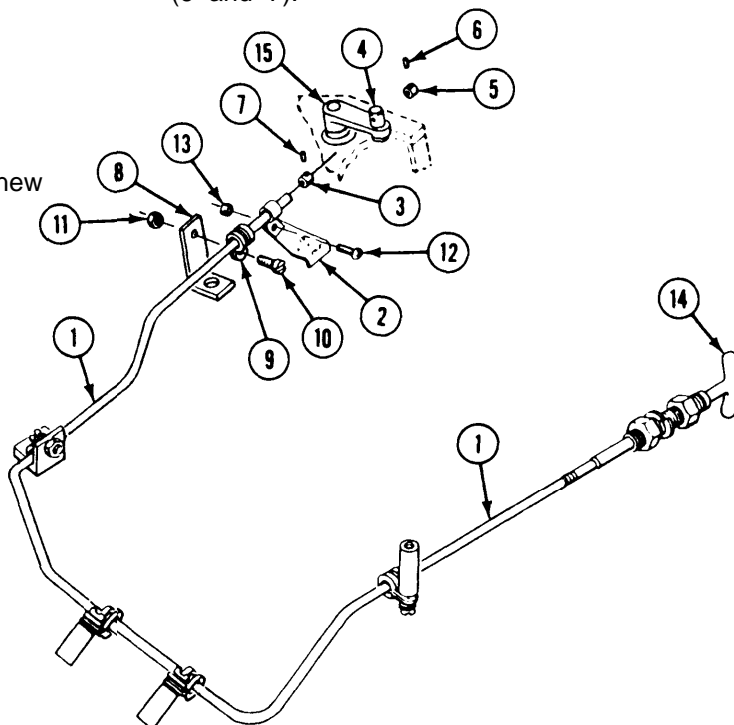

FOLLOW-THROUGH STEPS

1. Install power plant rear access panel (page 24-27) or (page 24-29).
2. Start engine (see your -10). Check that fuel shutoff cable operates properly.
3. Close power plant front access door and raise trim vane (see your -10).
4. Raise and lock ramp (see your -10).
5. Stop/shutdown engine (see your -10).

END OF TASK

**Section III. TRANSMISSION CONTROLS AND ENGINE POWER
DISCONNECT**

TASK INDEX

<u>Task</u>	<u>Page</u>	<u>Task</u>	<u>Page</u>
Replace Transmission Range Selector	23-48	Replace Neutral Start Switch	23-53
Repair Transmission Range Selector	23-50	Replace Range Selector Linkage	23-55
		Replace Engine Power Disconnect	23-57

REPLACE TRANSMISSION RANGE SELECTOR

DESCRIPTION

This task covers: Remove (page 23-48). Install (page 23-49).

INITIAL SETUP

Tools:

General Mechanics Tool Kit (Item 30, App D)

References:

See your -10

Materials/Parts:

Self-locking nut
Spring pin

Equipment Conditions:

Engine stopped/shutdown (see your -10)
Carrier blocked (see your -10)
Trim vane lowered and power plant front access door open (see your -10)
Driver's power plant access panel removed (page 24-25)
Air cleaner housing and element removed (page 7-7)

Personnel Required:

Unit Mechanic
Helper (H)

REMOVE

1. Remove screw (1) and locknut (2). Discard locknut.
2. Disconnect link (3) from arm (4).
3. Remove spring pin (5) and arm (4) from range selector (6). Discard spring pin.

4. Disconnect two electrical leads (7 and 8) from circuits 74 and 74A (all carriers except M741A1).
5. On M741A1 only, disconnect three electrical leads (9, 10, and 11) from circuits 14, 74, and 641F.
6. Remove three screws (12), washers (13), and range selector (6) from driver's compartment bulkhead.

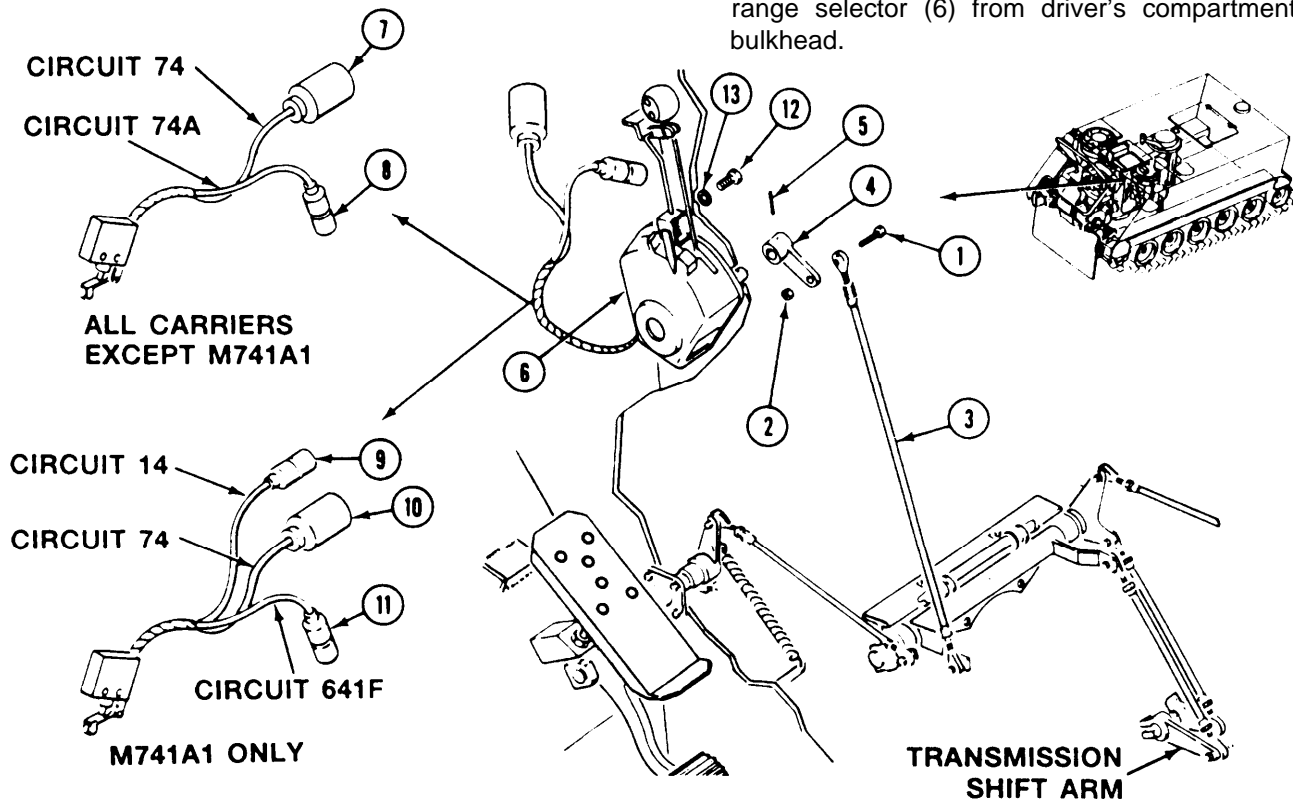

INSTALL

7. Place range selector (1) on driver's compartment bulkhead. Secure with three washers (2) and screws (3).
8. Install arm (4) on range selector (1). Secure with new spring pin (5).
9. Install link (6) on arm (4). Secure with screw (7) and new locknut (8).
10. Connect two electrical leads (9 and 10) to circuits 74 and 74A (all earners except M741A1).
11. On M741A1 only, connect three electrical leads (11, 12, and 13) to circuits 14, 74, and 641F.

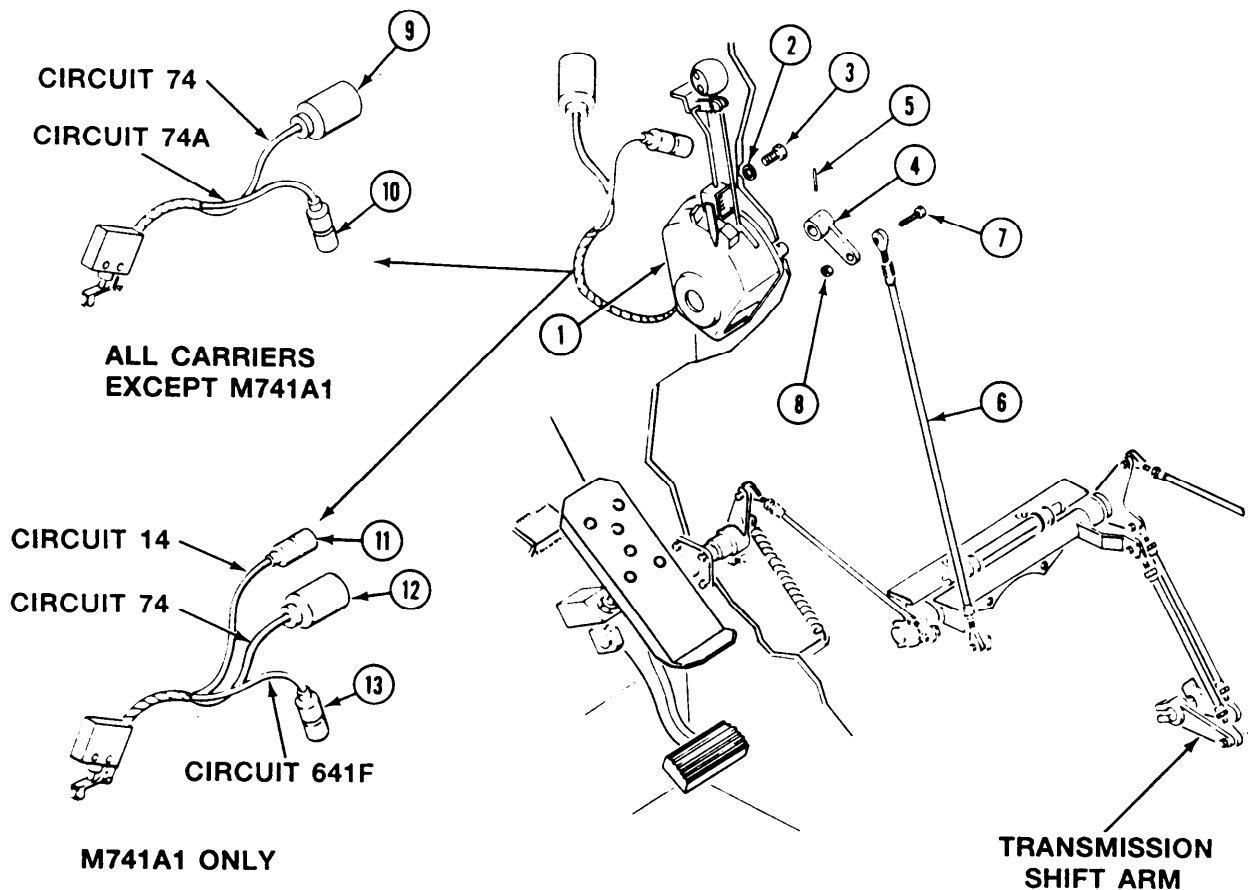

FOLLOW-THROUGH STEPS

1. Install air cleaner element and housing (page 7-7).
2. Install driver's power plant access panel (page 24-25).
3. Close power plant front access door and raise trim vane (see your -10).
4. Operate earner to check that transmission range selector operates properly.
5. Stop/shutdown engine (see your -10).

END OF TASK

REPAIR TRANSMISSION RANGE SELECTOR

DESCRIPTION

This task covers: Remove (page 23-50). Clean, Inspect, and Repair (page 23-51).
Install (page 23-52).

INITIAL SETUP

Tools:

General Mechanics Tool Kit (Item 30, App D)

Materials/Parts:

Cotter pin (4)
Lockwasher (2)
Spring pin (2)

Personnel Required:

Unit Mechanic

References:

See your -10

Equipment Conditions:

Engine stopped/shutdown (see your -10)
Carrier blocked (see your -10)
Ramp lowered (see your -10)
Trim vane lowered and power plant front access door open (see your -10)
Driver's power plant access panel removed (page 24-25)
Range selector removed from earner (page 23-48)

DISASSEMBLE

1. Remove two screws (1) and cover (2) from housing (3).
2. Remove two screws (4), washers (5), lockwashers (6), nuts (7), and neutral start switch (8) from housing (3). Discard lockwashers.
3. Remove cotter pin (9), pin (10), control lever assembly (11), and spring (12) from shaft (13). Discard cotter pin.
4. Remove spring pin (14) that secures cam (15) to shaft (13). Discard spring pin.
5. Remove cam (15) and shaft (13) from housing (3).

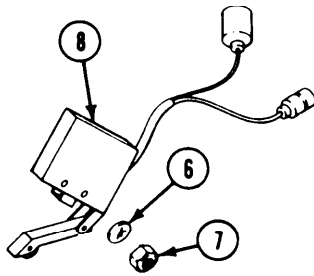
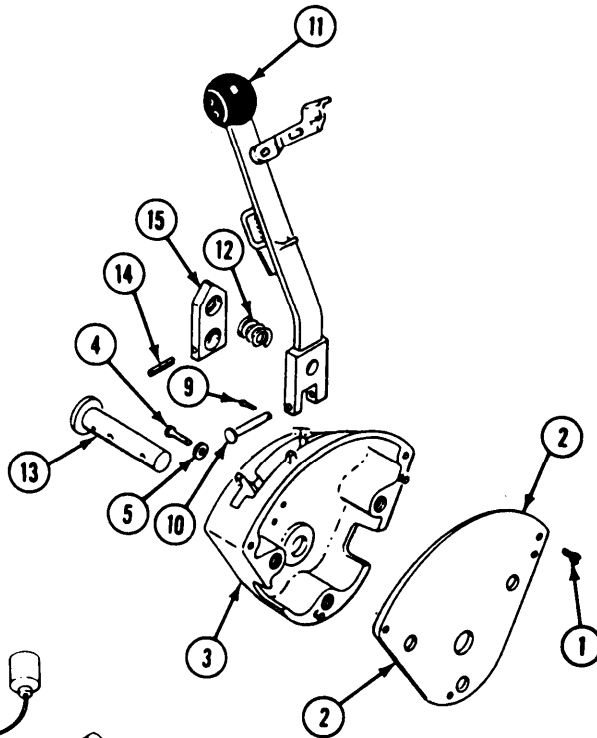

**ALL CARRIERS
EXCEPT M741A1**

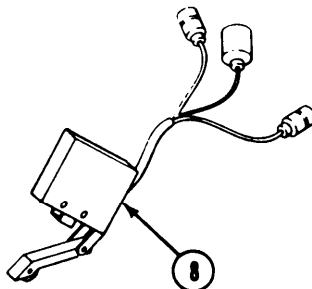

M741A1 ONLY

6. Remove three cotter pins (1), lock (2), spring (3), and washer (4) from control rod (5). Discard cotter pins.
7. Remove spring pin (6) and lock (2) from control lever (7). Discard spring pin.
8. Remove two pins (8) from housing (9).
9. Clean range selector parts with a clean, dry cloth.
10. Check neutral start switch leads and connectors. Replace bad leads or connectors (page 14-3).
11. Test neutral start switch (page 23-53). Replace bad switch.
12. Check springs (3 and 6). Replace broken or weak springs.
13. Check control rod, cam, and shaft. Replace cracked or worn parts.

CLEAN, INSPECT, AND REPAIR

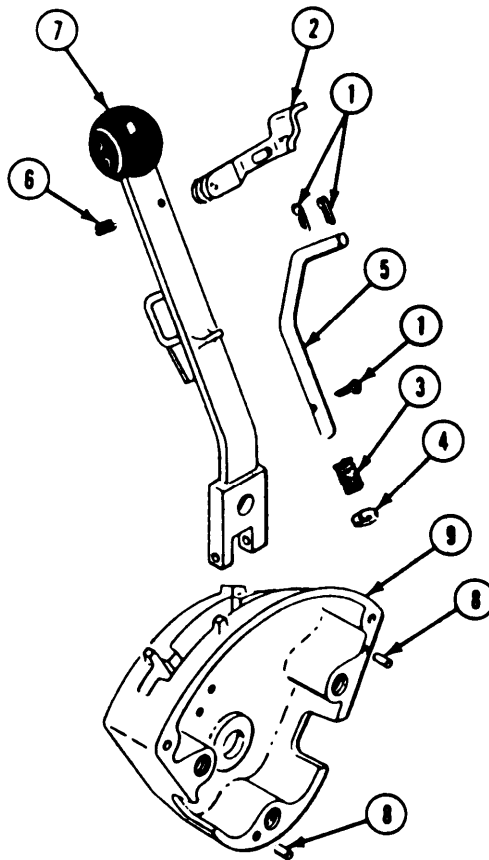

GO TO NEXT PAGE

ASSEMBLE

14. Install shaft (1) and cam (2) in housing (3). Secure cam to shaft with new spring pin (4).
15. Install control lever assembly (5) and spring (6) in housing (3). Secure control lever to shaft (1) with pin (7) and new cotter pin (8).
16. Install lock (9) on control lever (5). Secure with new spring pin (10).
17. Install control rod (11), spring (12), and washer (13) in control lever (5).
18. Secure rod (11) to lock (9) and lever (5) with three new cotter pins (14).
19. Install neutral start switch (15) in housing (3). Secure with two screws (16), washers (17), new lockwashers (18), and nuts (19).
20. Install two pins (20) in housing (3).
21. Secure cover (21) to housing (3) with two screws (22).
22. Install range selector in carrier (page 23-48).
23. Adjust range selector linkage (page 23-55).
24. Adjust neutral start switch (page 23-53).

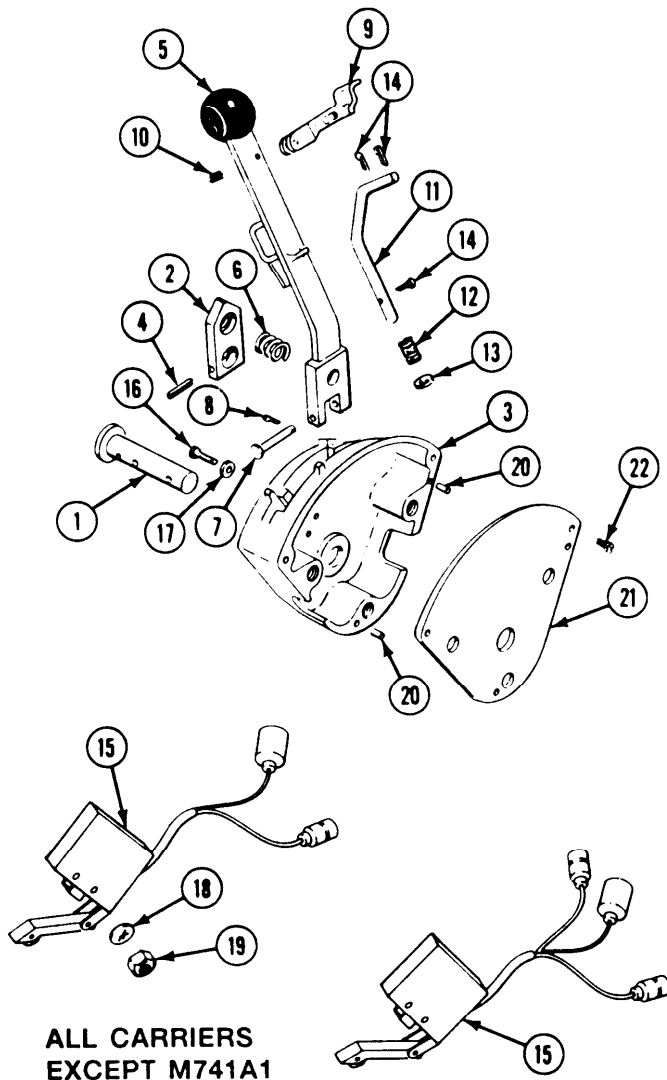

**ALL CARRIERS
EXCEPT M741A1**

M741A1 ONLY

FOLLOW-THROUGH STEPS

1. Install driver's power plant access panel (page 24-25).
2. Close power plant front access door and raise trim vane (see your -10).
3. Raise and lock ramp (see your -10).
4. Operate earner (see your -10). Check that transmission range selector operates properly.
5. Stop/shutdown engine (see your -10).

END OF TASK

REPLACE NEUTRAL START SWITCH

INITIAL SETUP

Tools:

General Mechanics Tool Kit (Item 30, App D)
Digital Multimeter (Item 43, App D)

Materials/Parts:

Lockwasher (2)

Personnel Required:

Unit Mechanic

References:

See your -10

Equipment Conditions:

Engine stopped/shutdown (see your -10)
Carrier blocked (see your -10)
Transmission range selector removed from carrier (page 23-48)

REMOVE

1. Remove two screws (1) and cover (2) from housing (3).
2. Remove two screws (4), washers (5), lockwasher (6), nuts (7), and neutral start switch (8) from housing (3). Discard lockwashers.

CLEAN, INSPECT, AND REPAIR

3. Clean switch with a clean, dry cloth.
4. Check neutral start switch (page 3-15).
5. Check switch. Replace switch that has worn or damaged arm or roller.
6. Check switch leads. Replace damaged leads (page 14-3) or switch.

INSTALL AND ADJUST

7. Install neutral start switch (8) on housing (3). Secure with two screws (4), washers (5), new lockwashers (6), and nuts (7). Do not tighten nuts.
8. Place selector (9) in neutral.
9. Slide neutral start switch (8) and attaching screws (4) up or down in elongated holes in housing (3) to set switch adjustment. Moving switch (8) down moves lever (10) closer to actuating cam (11). This increases selector (9) travel with switch actuated.

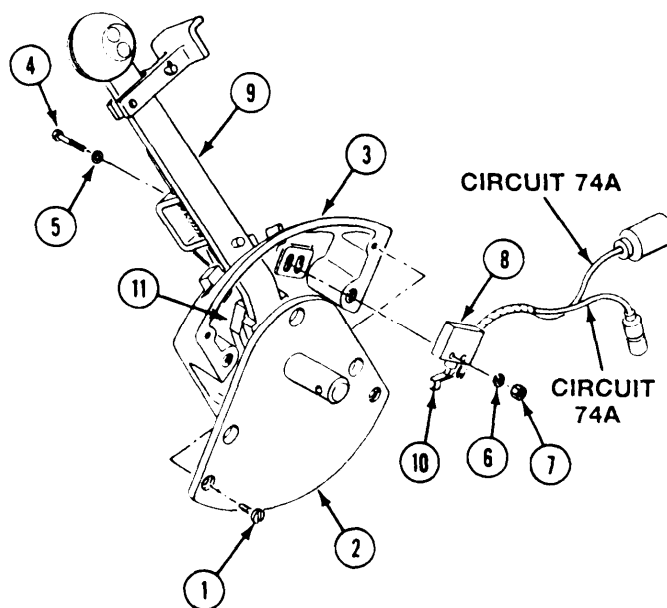

GO TO NEXT PAGE

10. Adjust neutral start switch (1) so that electrical continuity is maintained as follows, use digital multimeter:

- a. For all earners except the M741A1, the neutral start switch (1) must maintain electrical continuity between circuits 74 (2) and 74A (3) at the N position.
- b. For M741A1 carriers only, the neutral start switch (1) must maintain electrical continuity between circuits 74 (4) and 14 (5) at the N position.

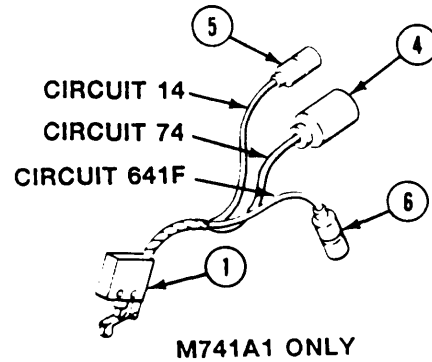

NOTE

Switch must break electrical continuity between circuits 74 (2) and 74A (3) and M741A1 circuits 74 (4) and 14 (5) before reaching R or 2-3 position when shifting from the N position.

For M741A1 earners only, switch must maintain electrical continuity between circuits 14 (5) and 641F (6) when selector is in any position except N.

- 11. When adjustment is correct, tighten two nuts (7).
- 12. Secure cover (8) to housing (9) with two screws (10).

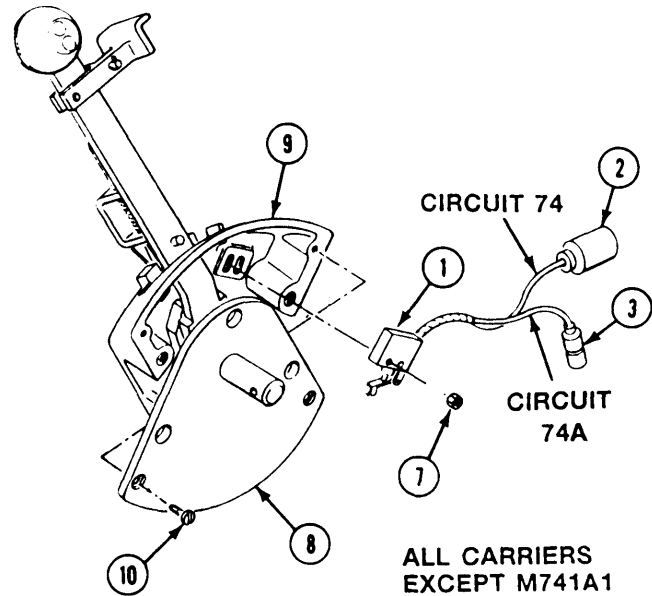

FOLLOW-THROUGH STEPS

- 1. Install range selector in earner (page 23-48).
- 2. Start engine (see your -10). Check that neutral start switch operates properly.
- 3. Stop/shutdown engine (see your -10).

END OF TASK

REPLACE RANGE SELECTOR LINKAGE

DESCRIPTION

This task covers: Remove (page 23-55). Clean, Inspect, and Repair (page 23-55).
Install (page 23-55). Adjust (23-56).

INITIAL SETUP

Tools:

General Mechanics Tool Kit (Item 30, App D)

Materials/Parts:

Self-locking nut (2)
Spring pin

Personnel Required:

Unit Mechanic

References:

See your -10

Equipment Conditions:

Engine stopped/shutdown (see your -10)
Carrier blocked (see your -10)
Air cleaner housing and element removed (page 7-7)
Air control valve removed (page 7-11)

REMOVE

- 1 Remove two screws (1), locknuts (2), and range selector link (3) from arm (4) and transmission cross-shaft (5). Discard locknuts.
- 2 Remove spring pin (6) and arm (4) from range selector (7). Discard spring pin.

CLEAN, INSPECT, AND REPAIR

- 3 Check arm (4) and link (3). Replace cracked, bent, or worn arm or link.

INSTALL

- 4 Secure arm (4) on range selector (7) with new spring pin (6).
- 5 Install range selector link (3) on arm (4) and transmission cross-shaft (5). Secure with two screws (1) and new locknuts (2).

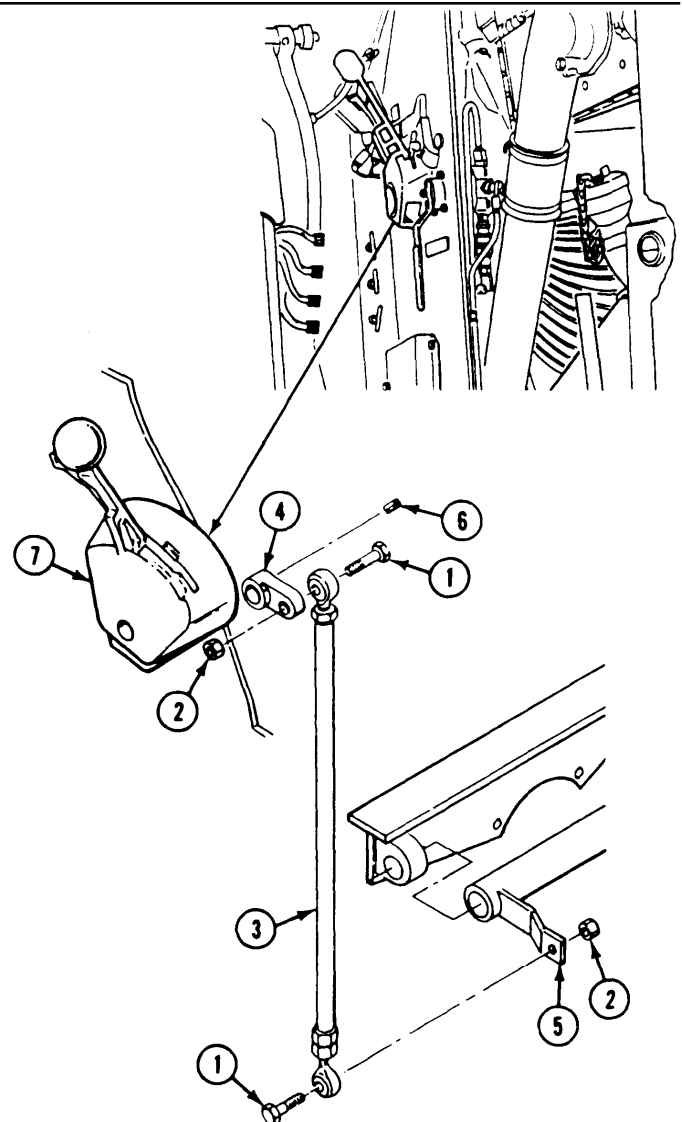

GO TO NEXT PAGE

ADJUST

6. Loosen locknut (1) on range selector link (2) at transmission cross-shaft (3) end.
7. Remove screw (4) and locknut (5) that secure range selector link (2) to transmission cross-shaft (3).
8. Place range selector (6) in neutral position.
9. Pull transmission shift arm (page 23-49) to end of travel, then back one detent to place transmission in neutral.
10. Adjust range selector link bearing end (7) to free pin fit at transmission cross-shaft (3).
11. Check all range selector positions. Readjust range selector link bearing end (7), if needed, to obtain positive transmission detents in all positions.
12. Install range selector link (2) on transmission cross-shaft (3). Secure with screw (4) and nut (5).
13. Tighten locknut (1) on range selector link bearing end (7).

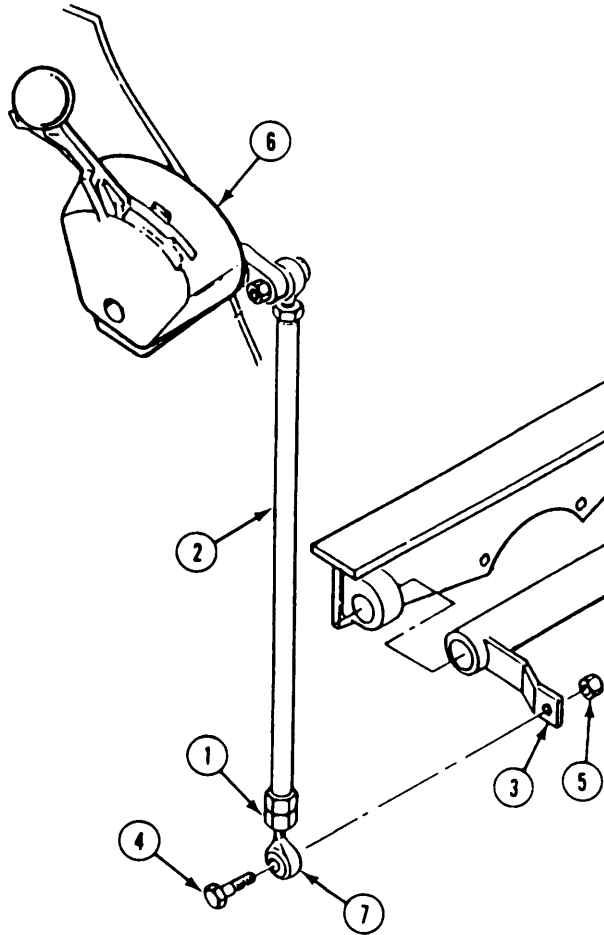

FOLLOW-THROUGH STEPS

- | | |
|---|--|
| <ol style="list-style-type: none"> 1. Install air control valve (page 7-11). 2. Install air cleaner housing and element (page 7-7). | <ol style="list-style-type: none"> 3. Operate carrier (see your -10). Check that range selector linkage operates properly. 4. Stop/shutdown engine (see your -10). |
|---|--|

END OF TASK

REPLACE ENGINE POWER DISCONNECT

DESCRIPTION

This task covers: Remove (page 23-57). Install (page 23-58). Adjust (page 23-59).

INITIAL SETUP

Tools:

General Mechanics Tool Kit (Item 30, App D)
Torque Wrench (Item 95, App D)

Materials/Parts:

Antiseize compound (Item 4, App C)
Cotter pin
Self-locking nut (2)
Tab washer (2)

Personnel Required:

Unit Mechanic

References:

See your -10

Equipment Conditions:

Engine stopped/shutdown and ramp lowered
(see your -10)
Carrier blocked (see your -10)
Power plant rear access panel removed
(page 24-27) or (page 24-29)
Driver's power plant access panel removed
(page 25-25)

REMOVE

1. Remove two screws (1), locknuts (2), supports (3), one lock (4), bushing (5) and spring (6) from lever (7). Discard locknuts.

2. Remove cotter pin (8) and pin (9) that secures lever (7) to arm (10). Discard cotter pin.
3. Remove lever (7) from guide (11).
4. Remove two screws (12), tab washers (13), and guide (11) from transmission housing. Discard tab washers.

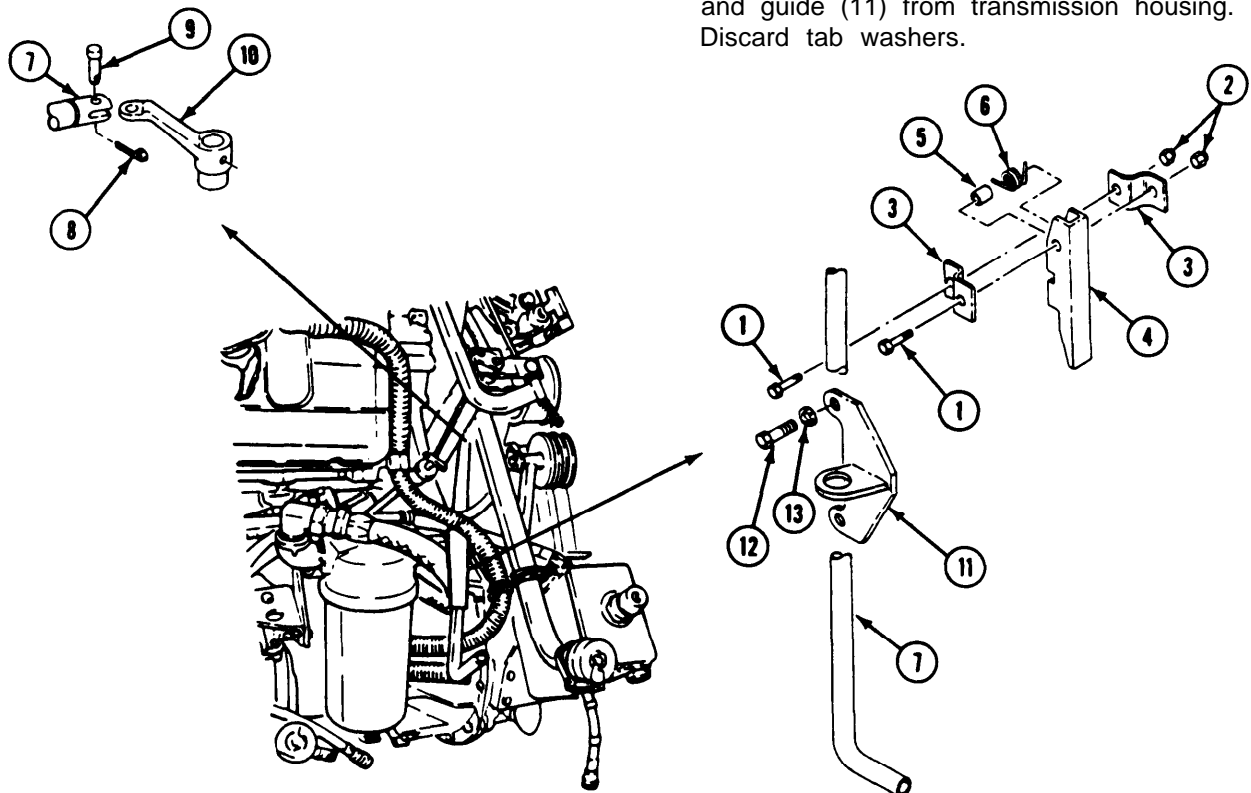

GO TO NEXT PAGE

INSTALL

5. Apply a light coat of antiseize compound to threads of two screws (1).
6. Install guide (2) on transmission housing. Secure with two screws (1) and new tab washers (3). Tighten screws to 253-300 in-lb (28-34 N-m) torque. Use torque wrench.
7. Insert lever (4) through guide (2). Secure to arm (5) with pin (6) and new cotter pin (7).
8. Install bushing (8), spring (9), lock (10), and two supports (11) on lever (4). Secure with two new locknuts (12) and screws (13).

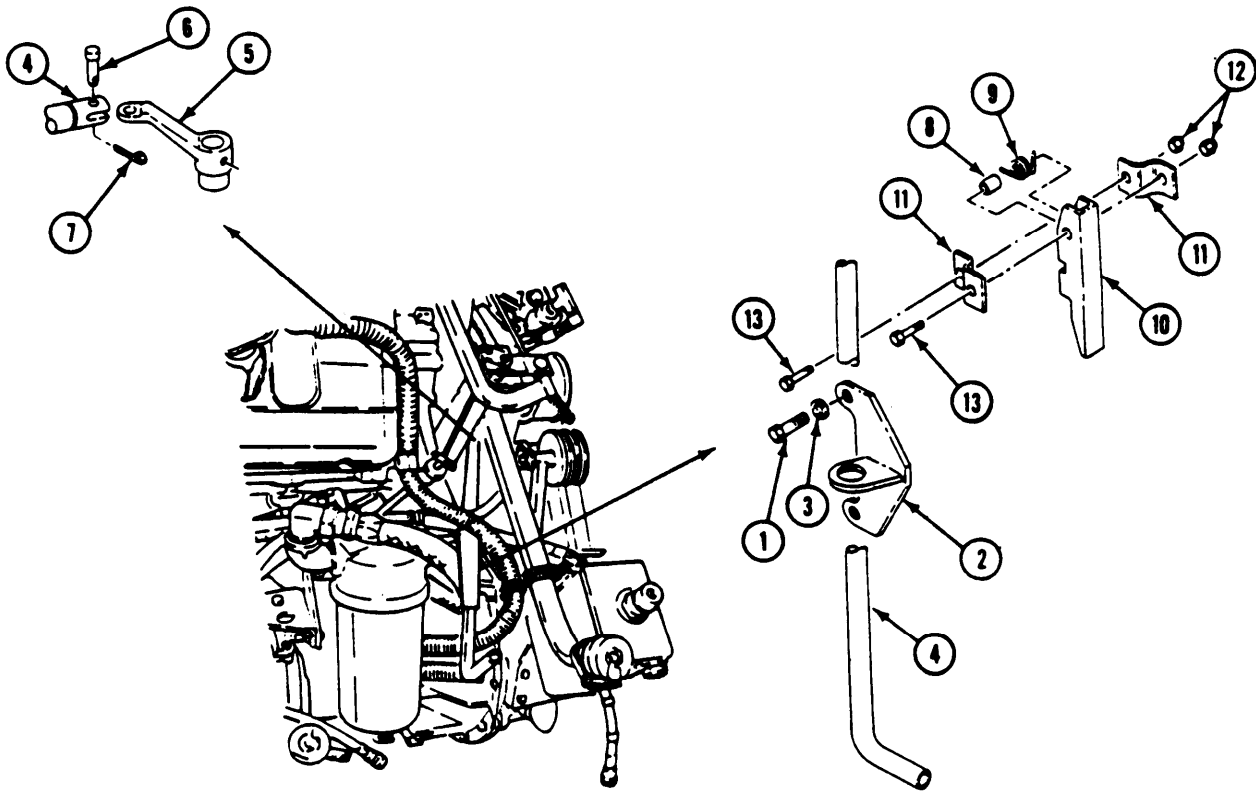

ADJUST

9. Lift lock (1) on control lever (2). Push lever in as far as it will go. This disconnects engine from the rest of power plant.
10. Loosen two screws (3) and nuts (4) that secure two supports (5), lock (1), spring (6), and bushing (7) to lever (2).
11. Move two supports (5) until the clearance between lock (1) and guide (8) is $1/32$ - $3/32$ in (0.8-2.4mm).
12. Tighten two screws (3) and locknuts (4).

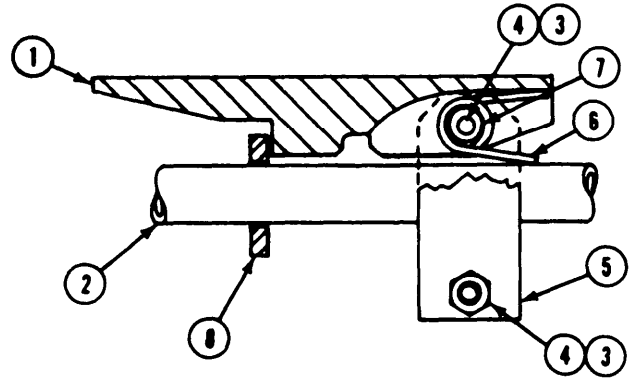

FOLLOW-THROUGH STEPS



WARNING
Loose clothing is dangerous around moving belts and pulleys. You could get badly hurt if your clothes get caught in moving parts.

1. Check engine disconnect operation. Push control lever in. Then start engine (see your -10). Fan and fan belts should not work. Stop engine. Pullout control lever. Then start engine (see your -10). Fan and fan belts should operate properly.
2. Install power plant rear access panel (page 24-27) or (page 24-29).
3. Install driver's power plant access panel (page 24-25).
4. Raise and lock ramp (see your -10).
5. Stop/shutdown engine (see your -10).

END OF TASK

Section IV. PIVOT STEER AND CONTROLS

TASK INDEX

<u>Task</u>	<u>Page</u>	<u>Task</u>	<u>Page</u>
Bleed Pivot Steer System	23-61	Repair Pivot Steer Master Cylinders and Hoses	23-66
Replace Pivot Steer Handles and Links	23-62	Replace/Repair Pivot Steer Brakes, Hoses, Tubes, and Fittings	23-68
Replace Pivot Steer Bellcranks and Brackets	23-64	Replace Pivot Steer Brake Disk	23-71
		Adjust Pivot Steer Linkage	23-72

BLEED PIVOT STEER SYSTEM

INITIAL SETUP

Tools:

General Mechanics Tool Kit (Item 30, App D)

Materials/Parts:

FRH hydraulic fluid (Item 19, App C)

Personnel Required:

Unit Mechanic
Helper (H)

References:

See your -10
See your LO

Equipment Conditions:

Engine stopped/shutdown (see your -10)
Ramp lowered (see your -10)
Carrier blocked (see your -10)
Trim vane lowered and power plant front access door open (see your -10)

BLEED

NOTE

Bleed one side of system (two caliper halves) at a time. Keep master cylinder full during bleeding.

1. Attach a short hose and container to bleeder valves (1) (one valve at a time).
2. Remove master cylinder cap (2). Fill cylinder with FRH hydraulic fluid (see your -10).
3. Open bleeder valves (1).
4. Move handle (3) until fluid coming out of bleeder valves (1) is free of air.
5. Hold handle (3) back in applied position (as shown) and close bleeder valves (1).
6. After bleeding, add FRH hydraulic fluid only as needed. Fluid level should be within 1/2-3/4-in (13-19mm) from top of cylinder. Do not overfill (see your LO).

TEST

Pull control handle to applied position and hold it there. If handle continues to move after applied position is reached, master cylinder, hose, tube, or connection is bad. Repair or replace bad parts (page 23-66).

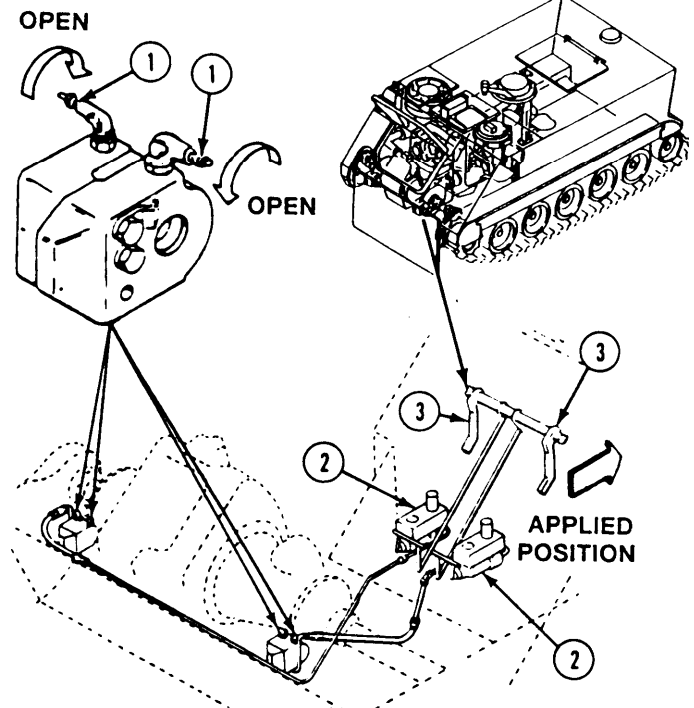

FOLLOW-THROUGH STEPS

1. Close power plant front access door and raise trim vane (see your -10).
 2. Raise and lock ramp (see your -10).
 3. Operate carrier (see your -10). Check that pivot steer system operates properly.
 4. Stop/shutdown engine (see your -10).
-

END OF TASK

REPLACE PIVOT STEER HANDLES AND LINKS

DESCRIPTION

This task covers: Remove (page 23-62). Clean, Inspect, and Replace (page 23-63).
Install (page 23-63).

INITIAL SETUP

Tools:

General Mechanics Tool Kit (Item 30, App D)

References:

See your -10

Materials/Parts:

Cotter pin (4)
Self-locking nut (4)

Equipment Conditions:

Engine stopped/shutdown (see your -10)
Carrier blocked (see your -10)
Driver's seat removed (page 24-127)

Personnel Required:

Unit Mechanic

REMOVE

1. Disconnect two springs (1) from two control handles (2) and brackets (3).
2. Remove four locknuts (4), screws (5), and two links (6) from two bellcranks (7) and control handles (2). Discard locknuts.
3. Remove four cotter pins (8), two shafts (9), and two control handles (2) from four mounts (10). Discard cotter pins.
4. Remove four nuts (11) and rod end bearings (12) from two links (6).

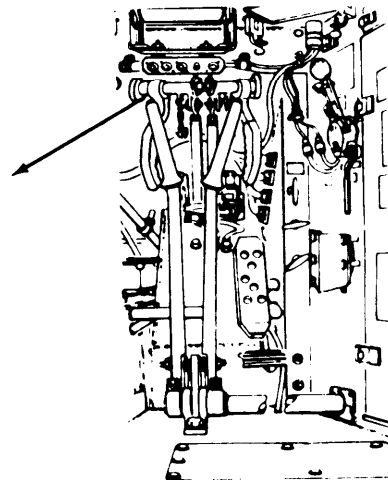
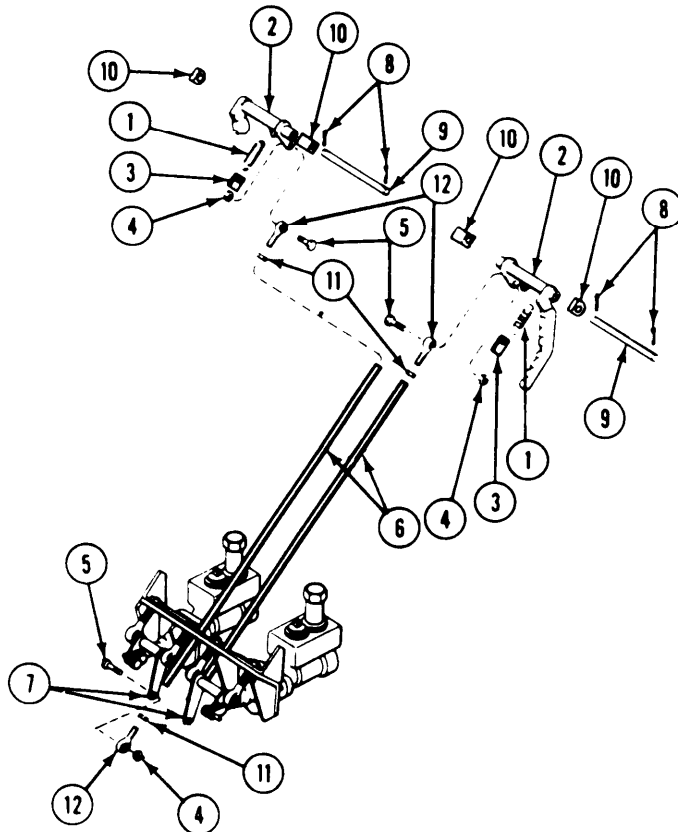

CLEAN, INSPECT, AND REPLACE

5. Check all parts for cracks, wear, and damage. Replace if needed.

INSTALL

6. Install four nuts (1) on rod end bearings (2).
7. Install four rod end bearings (2) in two links (3). Do not tighten nuts.
8. Install two links (3) on bellcranks (4). Secure with four screws (5) and new locknuts (6).
9. Place two handles (7) in four mounts (8). Secure with two shafts (9) and four new cotter pins (10).

10. Install two links (3) on handles (7). Secure with two screws (5) and nuts (6).
11. Attach two springs (11) to handles (7) and brackets (12).
12. Adjust pivot steer linkage (page 23-72).
13. Tighten four nuts (1) that secure rod end bearings (2) to two links (3).

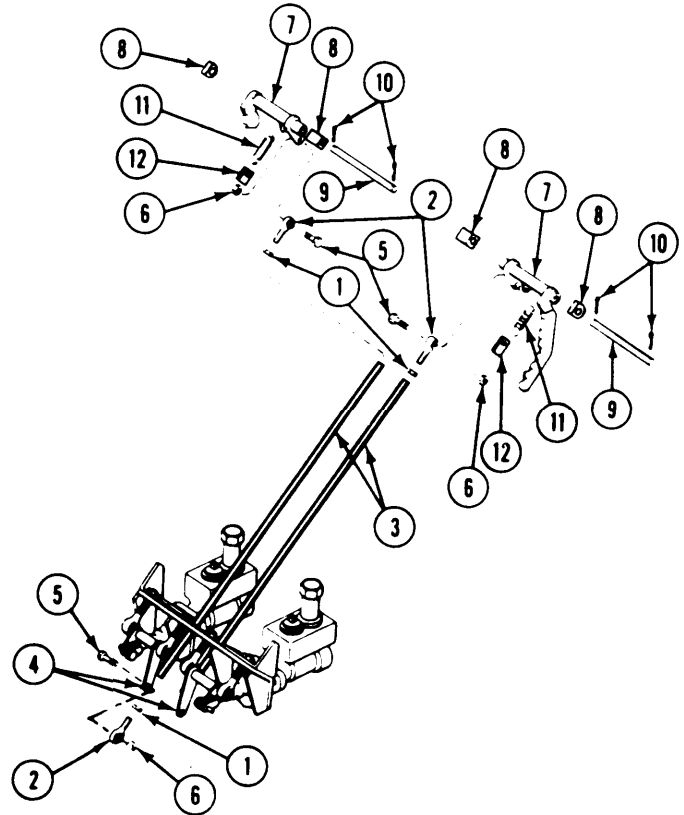

FOLLOW-THROUGH STEPS

1. Install driver's seat (page 24-127).
2. Operate carrier (see your -10). Check that pivot steer system operates properly.
3. Adjust pivot steering links (page 23-72).
4. Engine stopped/shutdown (see your -10).

END OF TASK

REPLACE PIVOT STEER BELLCRANKS AND BRACKETS

DESCRIPTION

This task covers: Remove (page 23-64). Clean, Inspect, And Replace (page 23-65).
Install (page 23-65).

INITIAL SETUP

Tools:

General Mechanics Tool Kit (Item 30, App D)

References:

See your -10

Materials/Parts:

Cotter pin (2)
Self-locking nut (10)

Equipment Conditions:

Engine stopped/shutdown (see your -10)
Carrier blocked (see your -10)
Ramp lowered (see your -10)
Driver's seat removed (page 24-127)

Personnel Required:

Unit Mechanic

REMOVE

1. Remove two cotter pins (1) and clevis pins (2) that secure two master cylinders (3) to levers and shafts (4). Discard cotter pins.
2. Remove six screws (5). Pull two master cylinders (3) away from mount (6) as far as possible.
3. Remove two screws (7), locknuts (8), and links (9) from levers and shafts (4). Discard locknuts.
4. Remove six screws (10), nuts (11), washers (12), and mount (6) from two brackets (13).
5. Remove eight locknuts (14), four rod ends (15), and two levers and shafts (4) from mount (6). Discard locknuts.

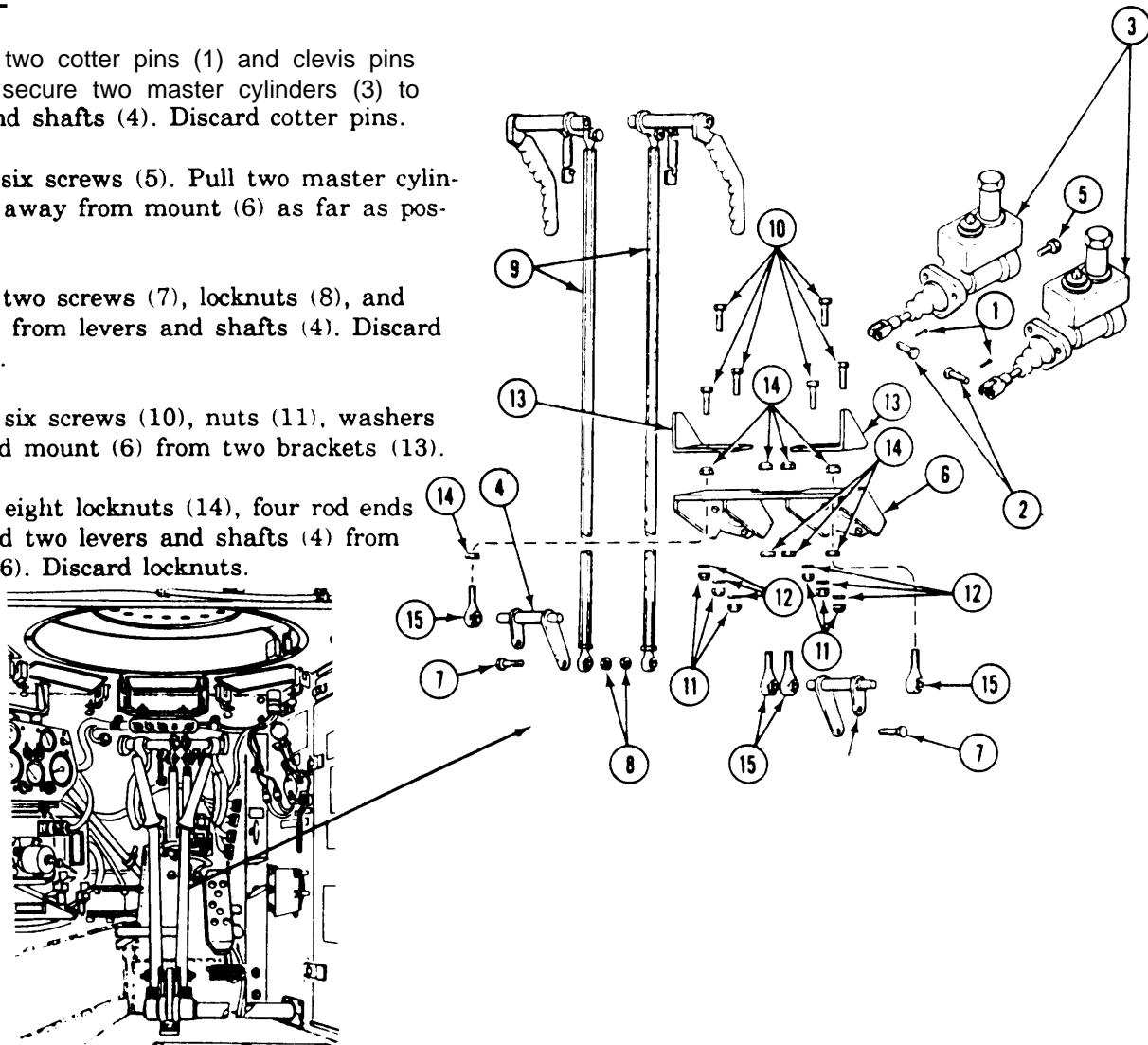

CLEAN, INSPECT AND REPLACE

6. Check all parts for cracks, wear and damage. Replace if needed.

INSTALL

7. Install four rod ends (1) on ends of levers and shafts (2).
8. Secure four rod ends (1) to mount (3) with eight new locknuts (4).
9. Install mount (3) on two brackets (5). Secure with six screws (6), washers (7), and nuts (8).
10. Install two links (9) to levers and shafts (2). Secure with two screws (10) and nuts (11).

11. Install two master cylinders (12) on mount (3). Secure with six screws (13).
12. Install two master cylinders (12) to levers and shafts (2). Secure with two clevis pins (14) and new cotter pins (15).
13. Adjust pivot steer linkage (page 23-72).

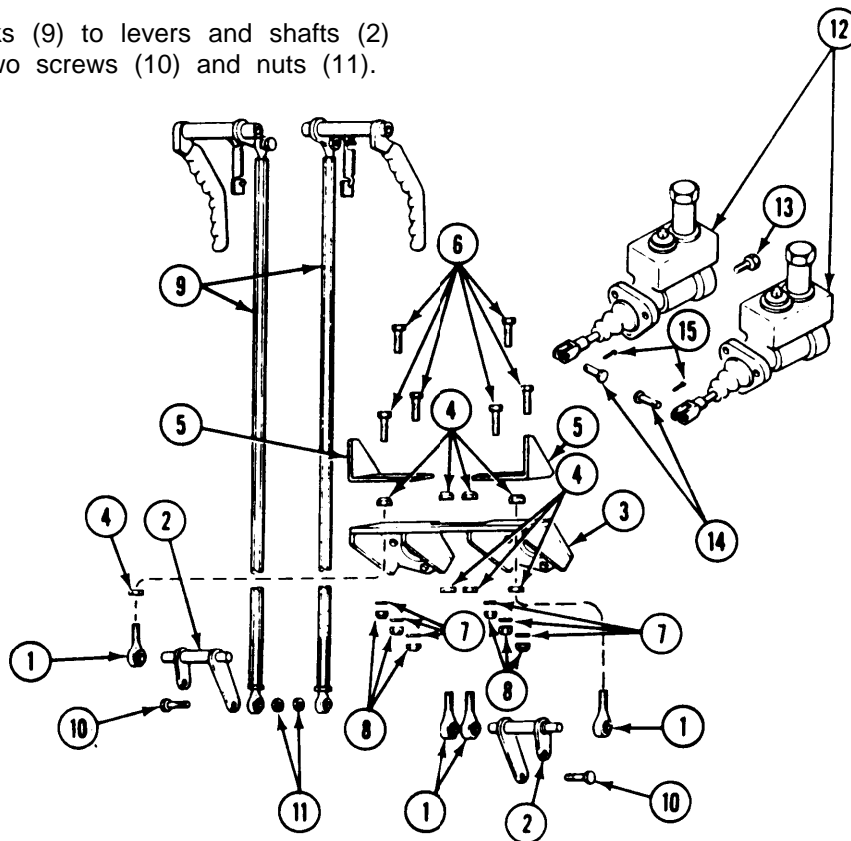

FOLLOW-THROUGH STEPS

1. Install driver's seat (page 24-127).
2. Start engine (see your -10).
3. Raise and lock ramp (see your -10).
4. Operate carrier (see your -10). Check that pivot steer system operates properly..
5. Stop/shutdown engine (see your -10).

END OF TASK

REPLACE PIVOT STEER MASTER CYLINDERS AND HOSES

DESCRIPTION

This task covers: Remove (page 23-66). Install (page 23-67).

INITIAL SETUP

Tools:

General Mechanics Tool Kit (Item 30, App D)

References:

See your -10

Materials/Parts:

FRH hydraulic fluid (Item 19, App C)
 Cotter pin (2)
 Preformed packing (2)
 Self-locking nut (3)

Equipment Conditions:

Engine stopped/shutdown (see your -10)
 Carrier blocked (see your -10)
 Ramp lowered (see your -10)
 Driver's seat removed (page 24-127)
 Pivot steer system drained (page 23-61)

Personnel Required:

Unit Mechanic

REMOVE

NOTE

Both master cylinders are removed and installed in the same way.

1. Remove hose (1), nut (2), and adapter (3) from elbow (4).
2. Remove elbow (4) and preformed packing (5) from master cylinder (6). Discard packing.
3. Remove cotter pin (7) and clevis pin (8). Disconnect clevis (9) from levers and shaft (10). Discard cotter pin.
4. Remove three screws (11), locknuts (12), and master cylinder (6) from support (13). Discard locknuts.
5. Remove master cylinder filler cap (14). Empty master cylinder (6).
6. Remove clevis (9) and bellows (15) from master cylinder (6).
7. Disconnect hose (1) from bulkhead elbow (16).

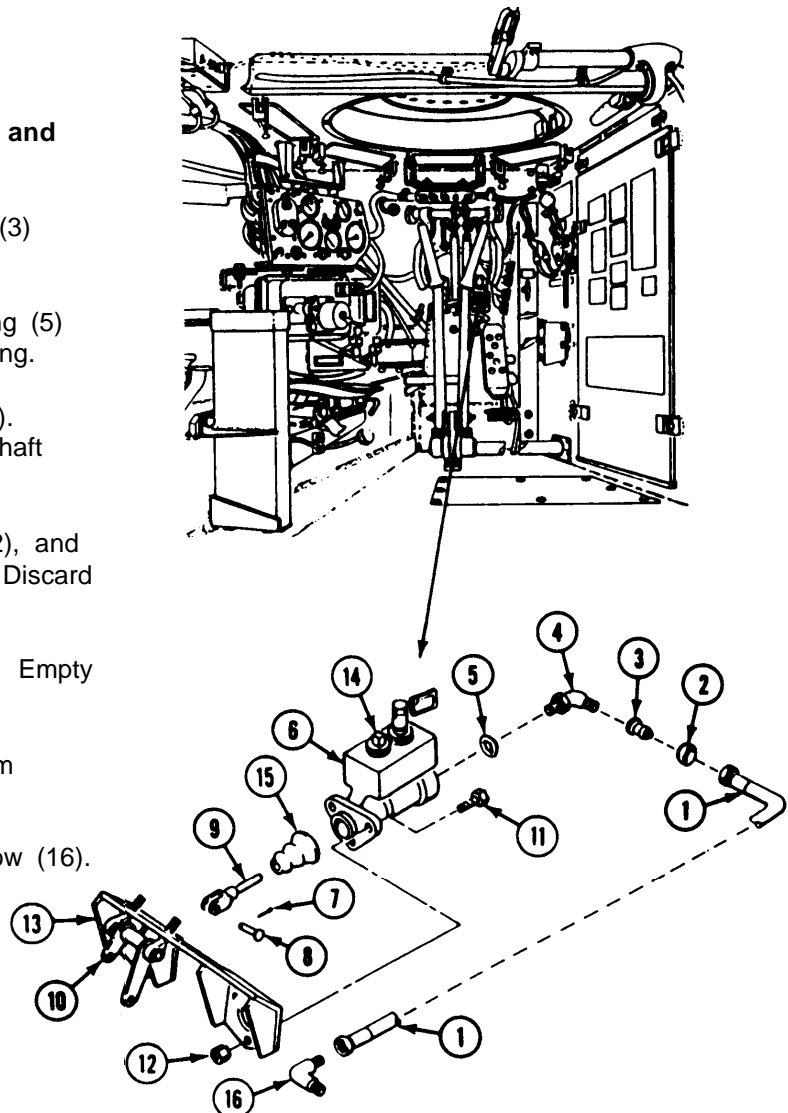

INSTALL

8. Install bellows (1) and clevis (2) in master cylinder (3).
9. Place master cylinder (3) on support (4). Secure with three screws (5) and new locknuts (6).
10. Install clevis (2) to levers and shaft (7). Secure with clevis pin (8) and new cotter pin (9).
11. Install new preformed packing (10) and elbow (11) in master cylinder (3).
12. Secure adapter (12), nut (13), and hose (14) to elbow (11).
13. Connect hose (14) to bulkhead elbow (15).
14. Bleed and fill pivot steer system (page 23-61). Install master cylinder filler cap (16).

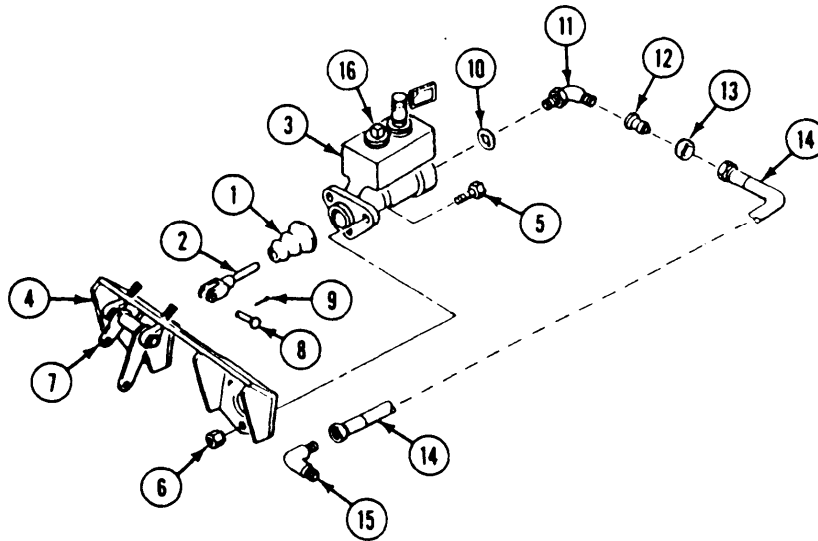
**FOLLOW-THROUGH STEPS**

1. Install driver's seat (page 24-127).
2. Start engine (see your -10). Check for hydraulic leaks.
3. Raise and lock ramp (see your -10).
4. Operate carrier to check that brake system operates properly.
5. Stop/shutdown engine (see your -10).

END OF TASK

REPLACE/REPAIR PIVOT STEER BRAKES, HOSES, TUBES, AND FITTINGS

DESCRIPTION

This task covers: Remove (page 23-68). Clean, Inspect, and Replace (page 23-69).
Install (page 23-69).

INITIAL SETUP

Tools:

General Mechanics Tool Kit (Item 30, App D)
Torque Wrench (Item 97, App D)

Materials/Parts:

FRH hydraulic fluid (Item 19, App C)
Packing (8)

Personnel Required:

Unit Mechanic

References:

See your -10
See your LO

Equipment Conditions:

Engine stopped/shutdown (see your -10)
Ramp lowered (see your -10)
Carrier blocked (see your -10)
Trim vane lowered and power plant front access door open (see your -10)
Hull front access cover removed (page 24-24)
Pivot steer system drained (page 23-61)

REMOVE

1. Remove four elbows (1) (with bleeder valves) and packings (2) from two pivot steer brakes (3). Discard packings.
2. Disconnect two hoses (4) from quick disconnect couplings (5).
3. Remove two couplings (5) from two elbows (6).
4. Remove six screws (7), washers (8), two clips (9), and two pivot steer brakes (3) from two pivot steer disks (10).
5. Remove brake linings (11) from each pivot steer brake half (3).
6. Remove two elbows (6), tubes (12), tees (13), tubes (14), elbows (15), and four packings (16) from two pivot steer brakes (3). Discard packings.
7. Remove two hoses (4) from tubes (17 and 18).
8. Disconnect tubes (17 and 18) from elbows (19).

9. Remove five screws (20), washers (21), clamps (22), and tubes (17 and 18) from five weldnuts (23).
10. Remove two nuts (24) and elbows (19) from bulkhead.

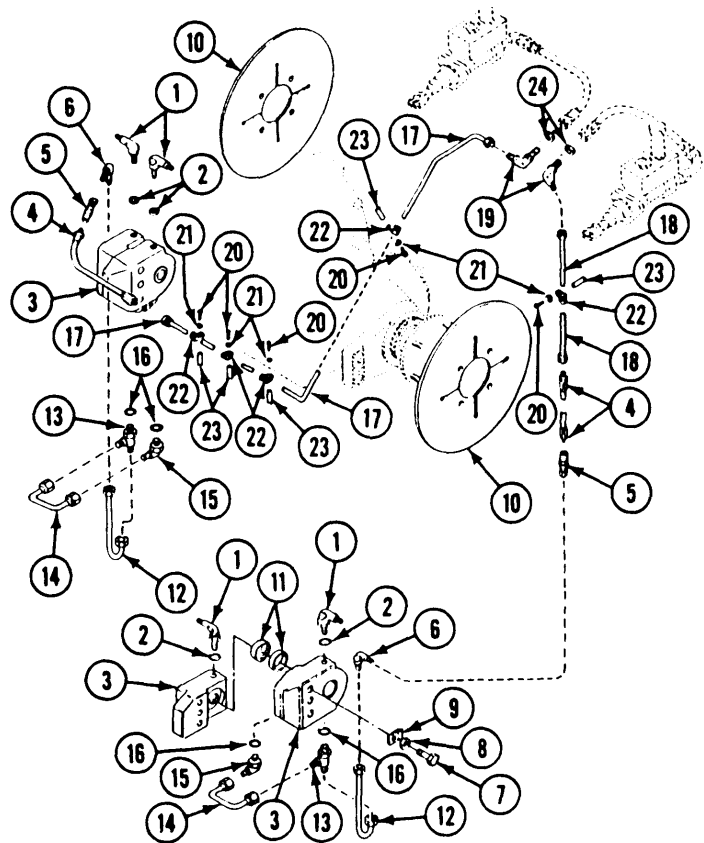

CLEAN, INSPECT, AND REPLACE

11. Check all parts for cracks, wear, and damage. Replace if needed.

INSTALL

12. Install four new packings (1), two elbows (2), and tees (3) in pivot steer brakes (4).
13. Connect two tubes (5) to tees (3) and elbows (2).
14. Connect two tubes (6) to tees (3).
15. Install two elbows (7) in tubes (6).
16. Install four elbows (8) (with bleeder valves) and four new packings (9) in pivot steer brakes (4).

CAUTION

Do not scratch brake cylinder walls when pushing brake pistons to bottom of cylinders

17. Using a suitable tool, push brake pistons (10) into pivot steer brake halves (4) until pistons bottom out.
18. Install one brake lining (11) in each pivot steer brake half (4).

19. Place two brakes (4) on pivot steer disks (12). Secure with six screws (13), washers (14), and two clips (15).
20. Tighten six screws (13) to 100-110 lb-ft (136-149 N-m) torque. Use torque wrench.
21. Connect two hoses (16) and quick disconnect couplings (17) to elbows (7).
22. Install two elbows (18) in bulkhead. Secure with two nuts (19).
23. Connect two tubes (20 and 21) to elbows (18) and hoses (16).
24. Install two tubes (20 and 21) to five weld-nuts (22). Secure with five clamps (23), washers (24), and screws (25).
25. Fill pivot steer system (see your LO).
26. Bleed pivot steer system (page 23-61).

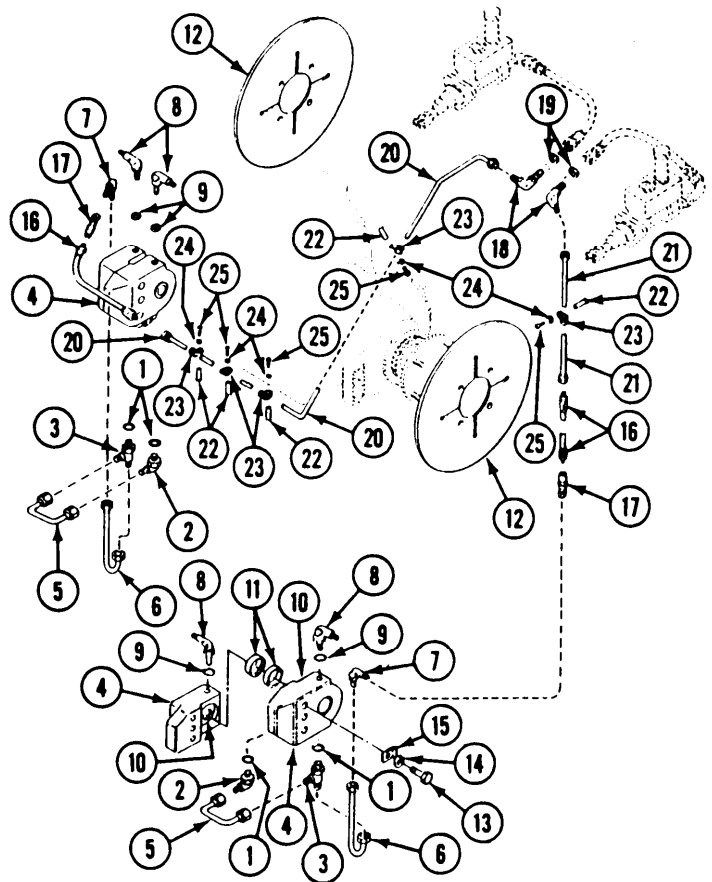

GO TO NEXT PAGE

FOLLOW-THROUGH STEPS

1. Close power plant front access door and raise trim vane (see your -10).
 2. Install hull front access cover (page 24-24).
 3. Start engine (see your -10). Check for hydraulic leaks.
 4. Raise and lock ramp (see your -10).
 5. Unblock carrier and operate earner (see your -10). Check that pivot steer system operates properly.
 6. Stop/shutdown engine (see your -10).
-

END OF TASK

REPLACE PIVOT STEER BRAKE DISK

INITIAL SETUP

Tools:

General Mechanics Tool Kit (Item 30, App D)
Torque Wrench (Item 96, App D)

Materials/Parts:

Self-locking nut (4)

Personnel Required:

Unit Mechanic

References:

See your -10

Equipment Conditions:

Engine stopped/shutdown (see your -10)
Drive shaft removed (page 20-5)
Brake removed (page 23-68)
Carrier blocked (see your -10)

NOTE

Left and right brake disks are removed and installed in the same manner.

REMOVE

1. Remove four locknuts (1), adapter (2), and brake disk (3) from differential output shaft. Discard locknuts.

INSTALL

2. Install new brake disk (3) and adapter (2) on differential output shaft. Secure with four new locknuts (1). Tighten nuts to 75-80 lb-ft (102-108 N-m) torque. Use torque wrench.

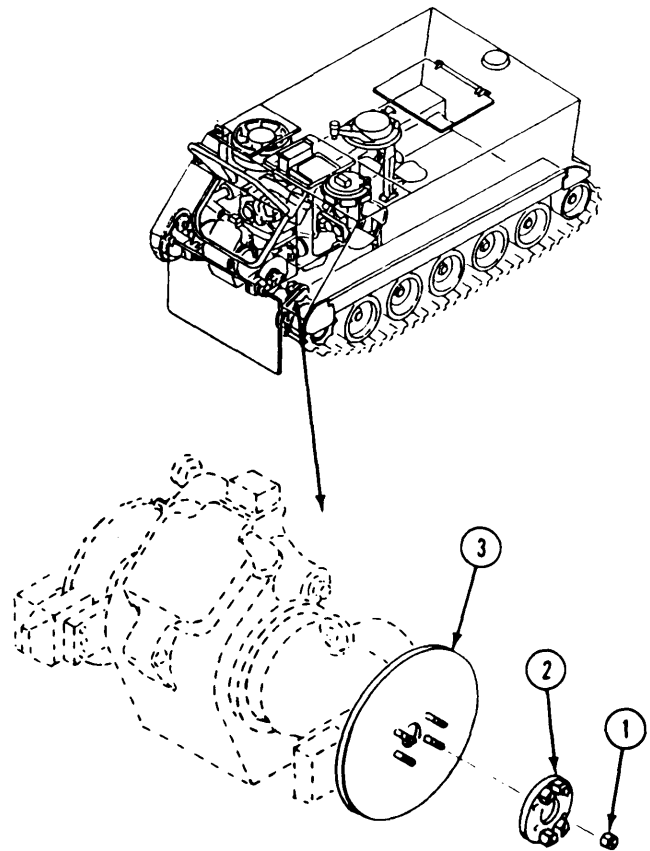

FOLLOW-THROUGH STEPS

1. Install drive shaft (page 20-5).
2. Install brake (page 23-68).

END OF TASK

ADJUST PIVOT STEER LINKAGE

INITIAL SETUP

Tools:

General Mechanics Tool Kit (Item 30, App D)

References:

See your -10

See your LO

Materials/Parts:

FRH hydraulic fluid (Item 19, App C)

Self-locking nut (2)

Equipment Conditions:

Engine stopped/shutdown (see your -10)

Carrier blocked (see your -10)

Ramp lowered (see your -10)

Driver's seat removed (page 24-127)

Personnel Required:

Unit Mechanic

ADJUST

1. Remove two locknuts (1), screws (2), and rod end bearings (3) from two control handles (4). Discard locknuts.
2. Push two control handles (4) forward to full release position.
3. Move two master cylinder's clevises (5) until contact with master cylinder internal piston is made.

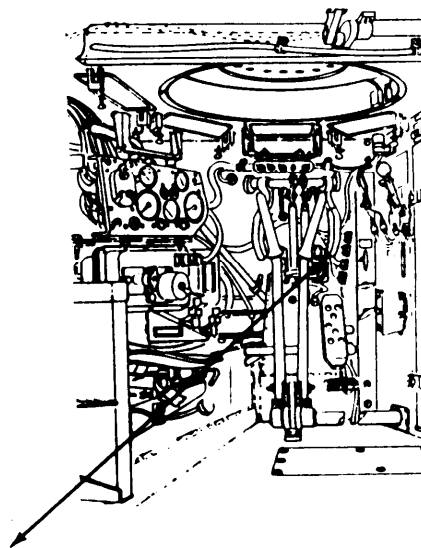
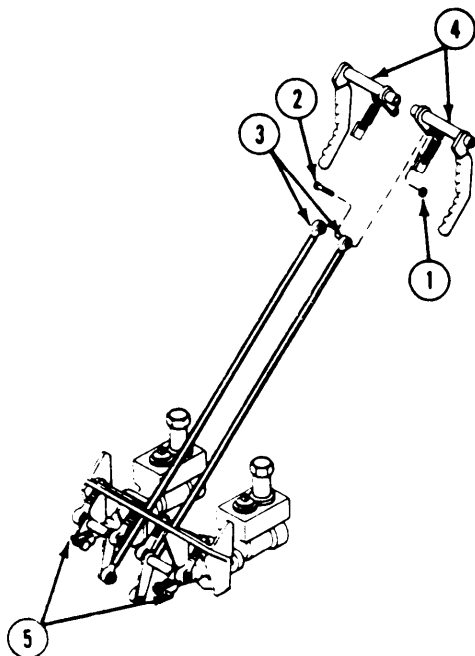

4. Pull master cylinder piston all the way in.

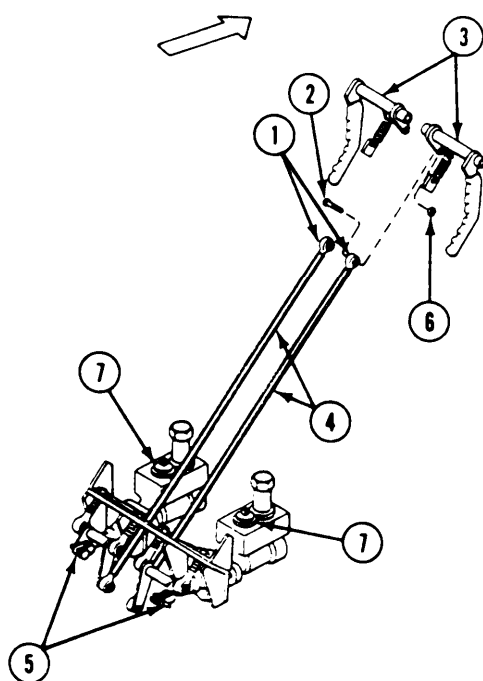
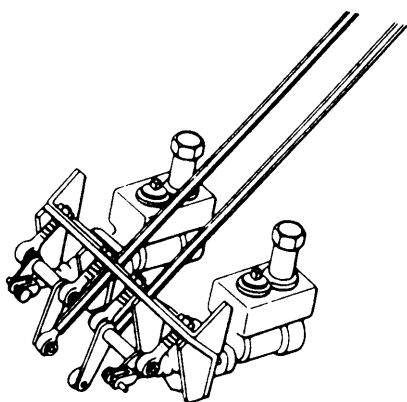

5. Turn two rod end bearings (1) until two screws (2) pass freely through two rod end bearings and two control handles (3).
6. Turn two rod end bearings (1) one turn to the left to lengthen two rods (4). Obtain 1/32 in (0.8 mm) clearance between master cylinder clevis (5) and master cylinder internal piston.
7. Install two rod end bearings (1) on control handles (3). Secure with two screws (2) and new locknuts (6).
8. Tighten locknuts (6) on rod end bearings (1).

CAUTION

Use FRH hydraulic fluid only (see your LO).

9. Remove two master cylinder filler caps (7). Fill master cylinders to 1/2–3/4 in (13-19 mm) from top. Install filler caps.

FOLLOW-THROUGH STEPS

1. Install driver's seat (page 24-127).
2. Raise and lock ramp (see your -10).
3. Operate carrier (see your -10). Check that pivot steer system operates properly. Check for hydraulic leaks.
4. Stop/shutdown engine (see your -10).

END OF TASK

ALPHABETICAL INDEX

Subject, Page

A

Accelerator:
 Linkage:
 Lower, transmission, repair, 23-29
 Lower, transmission, replace, 23-25
 Transmission throttle valve and, adjust, 23-34
 Upper, repair, 23-33
 Upper, replace, 23-31
 Pedal, lower, replace, 23-22
 Pedal assembly, upper, replace, 23-23
 Access panel, power plant, driver's, replace, 24-25
 Access panels, power plant:
 Rear, M577A2, M106A2, M125A2, M1068 M1064, replace, 24-29
 Rear, M1059, replace, 24-28.1
 Rear, M113A2, M901A1, replace, 24-27
 Adapter:
 Drum, M113A2 M1059, 34-3
 Gun mount assembly, replace, 38-5
 Speedometer cable and, replace, 11-17
 Tachometer cable and, replace, 11-14
 Adapter access plate:
 Cover assembly fog oil quick disconnect, to hose, M1059, replace, 40-33
 Fog oil tank quick disconnect to hose, M1059, replace, 40-31
 Smoke generator compressor reservoir to air hose, M1059, replace, 40-29
 Smoke generator control panel to electrical cable assembly, M1059, replace, 40-16
 Smoke generator, gasket, M1059, replace, 40-27
 Smoke generator to cover assembly air hose, M1059, replace, 40-30
 To generator electrical cable assembly, M1059, replace, 40-18
 Adapters and the conversion formula, use of torque wrench, 2-29
 Admittance buzzer:
 And switch, M577A2, M1068, replace, 12-72
 Right rear utility outlet works improperly, M577A2, 3-122
 Air box:
 Drain hoses, tubes, and fittings, replace, 4-9

Subject, Page

A (cont)

Air box (cont):
 Engine air inlet elbow to heater hoses, 6-112
 Heater:
 Air pump, replace, 6-133
 Air pump vanes, replace, 6-135
 Ignition coil, replace, 6-132
 Replace, 6-138
 Solenoid valve, replace, 6-136
 To fuel return tee tube and hose, 6-115
 Wiring harness, replace, 6-140
 Air cleaner:
 Cover, replace, 7-5
 Element, service, 7-2
 Hoses, replace, 7-3
 Housing, replace, 7-7
 Restriction indicator and hose, replace, 7-9
 Air compressor:
 Assembly, M1059, replace, 40-19
 Electrical cable assembly, M1059, replace, 40-13
 Air control valve:
 Cable, replace, 7-13
 Repair, 7-11
 Air intake and exhaust pipes:
 Air purifier:
 And frame, M8A3/M14 NBC, M113A2, replace, 39-93
 And frame, M8A3/M13, M577A3, replace, 39-32
 And frame, M8A3/M3 NBC, M106A2, M125A2, replace, 39-46
 And frame, M13, M1068, replace, 39-59
 Personnel heater:
 Replace, M106A2, M1064, M125A2, 29-55
 Replace, all except M106A2, M125A2, 29-53
 Air ventilator, rear compartment, replace, 24-117
 Alarm cable, M113A2, replace, 44-5
 Allocation chart, maintenance, B-1
 Ammunition:
 Rack:
 Horizontal, M125A2, 24-189
 Horizontal, M1064, replace, 24-190.3
 Horizontal, M1064, repair, 24-190.5

Subject, Page

A (cont)

Ammunition (cont):
 Rack (cont):
 Horizontal, M106A2, 24-191
 Vertical, M125A2, M106A2, 24-188
 Vertical, M1064, 24-190.1
 Stowage rack:
 M901A1, replace, 24-266
 Anchor, torsion bar, replace, 22-36
 Antenna:
 ■ Covers, replace, 24-241
 Guard, replace, 24-240
 Mast bracket assembly (M1068 ONLY),
 replace, 24-276
 Appendix A (references), A-1
 Appendix B (maintenance allocation chart), B-1
 Appendix C (expendable/durable supplies and
 materials list), G-1
 Appendix D (common tools and supplements and
 special tools/fixtures list), D-1
 Appendix E (fabricated tools), E-1
 Arm, idler wheel:
 ■ Replace, 22-23
 Armor:
 Shields:
 Commander's cupola, M113A2, M106A2,
 M125A2, M1064, M1059, replace, 38-2
 Mounting arm lock assembly and mount,
 M113A2, replace, 38-10
 Bear, M113A2, replace, 38-8
 Side, M901A1, replace, 24-120
 Smoke generator, M1059, replace, 40-6
 Artillery, communication:
 Inside cable, M577A2, replace, 37-5
 Assembly:
 Chain:
 Repair, M113A2, 36-3
 Replace, M113A2, 36-2
 Cooling fan, replace, 8-44
 Drum, M113A2, M1059, replace, 34-2
 Filter switch, M3 NBC, M106A2, M125A2,
 replace, 39-49
 Filter switch, M3 NBC, M113A2 ambulance,
 replace, 39-83
 Orifice connector, support, quick coupling half,
 M8A3/M13/M14, M113A2, M1059,
 M577A2, M1068, replace, 39-34
 Orifice connector, supports, quick disconnect
 couplings, M8A3 NBC, M106A2, M125A2,
 replace, 39-41

Subject, Page

A (cont)

Assembly (cont):
 Post:
 Repair, M113A2, 36-6
 Replace, M113A2, 36-5
 Regulator:
 100/200 amp, replace, 9-40
 Switch, cables, M8A3/M14 NBC, M113A2,
 M1059A2, replace, 39-95
 Switch, cables, M8A3 NBC, M106A2,
 M125A2, replace, 39-43
 Switch, cables, brackets, M8A3 NBC,
 M577A2, replace, 39-27
 Auxiliary generator, M1068 ONLY
 Fuel return hose, 28.1-10
 Fuel shutoff valve, replace, 28.1-2
 Fuel supply hoses, replace, 28.1-4, 28.1-7
 Auxiliary power, (slave) receptacle:
 NATO, M577A2, M1068, replace, 9-10
 Replace, all except M577A2, M1068, 9-2
 Replace, M577A2, M1068, 9-6
 Auxiliary tank:
 Deaeration hoses, replace, 8-32
 Parts, and, replace, 8-28
 Tube, to coolant pump, replace, 8-30
 Tube, to radiator, replace, 8-31

 B
 Balance hose, replace, 8-24
 Bar, torsion, replace, 22-32
 Bar, torsion, anchor, replace, 22-36
 Base, cushion, low stow, M901A1, replace,
 24-121
 Base, guard plate, and, M113A2, M1059,
 M109A1, replace, 27-2
 Battery:
 Access cover (M1068 ONLY), replace, 13-6.1
 Leads (M1068 ONLY), replace 13-6.3
 Box insulation and heat exchanger (M1068
 ONLY), 13-35
 Access cover, remove/install, M577A2, 13-6
 Box, all except M125A2, M1064, M106A2,
 repair, 13-22
 Box cover, M113A2, M901A1, M1059, repair, ■
 13-20
 Box, insulation and heat exchanger:
 Replace, M113A2, M901A1, M1059, 13-37
 Replace, M577A2, M1068, 13-35
 Cable, M113A2, replace, 44-6

Subject, Page

B (cont)

Battery (cont):

- Cover and leads, M113A2, M901A1, M1059, replace, 13-3
- Drawer, M106A2, M1064, M125A2, repair, 13-24
- Drawer, insulation and heat exchanger, M106A2, M1064, M125A2, replace, 13-32
- Generator indicator malfunctions, 3-143
- Ground lead, disconnect/connect, 13-2
- Leads:
 - Replace, M106A2, M1064, M125A2, 13-10
 - Replace, M1068, 13-6.1
 - Replace, M577A2, 13-7
- Radio harness, to, M1059, M901A1, M113A2, replace, 13-27
- Retainers, and, all except M106A2, M1064, M125A2, replace, 13-16
- Retainers, M106A2, M1064, M125A2, replace, 13-18
- Bearing and housing, pulley drive shaft, replace, 8-46
- Bellcranks and brackets, pivot steer, replace, 23-64
- Belts:
 - Fan drive, replace, 8-35
 - Generator drive:
 - 100 amp, replace, 9-29
 - 200 amp, replace, 9-47
- Bilge pump:
 - Circuit breakers, replace, 16-12
 - Front and/or rear, and/or lights, do not operate, 3-201
 - Pipes, front, replace, 16-5
 - Pipes, rear, replace, 16-11
 - System schematic, 3-206
- Bilge pump and strainer:
 - Front, replace, 16-2
 - Rear, replace, 16-8
- Bilge valve, front, replace, 16-7
- Blackout curtain and frame, M577A2, M1068, replace, 24-171
 - And tables (M1068 ONLY), replace, 24-170, 3-122
- Blackout drive light does not work, 3-75
- Blackout headlight:
 - Repair, 12-10
 - Replace, 12-9
- Blackout marker light:
 - Repair, 12-8

Subject, Page

B (cont)

Blackout marker light (cont):

- Replace, 12-7
- Blackout marker lights and/or tail lights do not operate, 3-93
- Blackout and/or service stop lights malfunction, 3-89
- Blower:
 - Compartment, M577A2, M1068, replace, 17-15
 - Left rear utility outlet/blower does not work, M577A2, 3-125
 - Switch, M577A2, M1068, replace, 17-16
- Board, map, M577A2, replace, 24-247
- Board, map, M1068, replace, 24-248.1
- Box:
 - Communication equipment (M1068 ONLY), replace
 - AC power extension A6, 40.1-48
 - AC power extension A7, 40.1-12
 - DC power extension A8, 40.1-13
 - DC power extension A9, 40.1-48
 - External communication All 40.1-18
 - LAN ground A15, repair, 40.1-16
 - LAN ground A15, 40.1-15
 - Power supply storage, 40.1-43
 - Power distribution A3, 40.1-49
 - Power entry A4, 40.1-54
 - Signal patch panel A10, 40.1-21
 - Switch box A18, 40.1-14
 - Tent interface panel A5, 40.1-46
 - UPS power extension A16 and A17, 40.1-8
- Distribution:
 - Repair, M113A2, 44-4
 - Replace, M113A2, 44-2
- Distribution, 200 amp generator system
 - M1068, replace, 12-23
- Grenade stowage, M106A2, M1064, M125A2, replace, 24-250
- Map, storage, M1068:
 - Repair, page 24-248.3
 - Replace, page 24-248.2
- Periscope stowage, M106A2, M1064, M125A2, replace, 24-251
- Spare IR (M19) periscope stowage, replace, 24-239
- Bracket:
 - Commander's seat post, M8A3/M3 NBC, M106A2, M125A2, replace, 39-48
 - Fuel filter mounting, replace, 6-130

Subject, Page

B (cont)

Bracket (cont):

- Fuel filter, mounting, M577A2, M1068 with 200 amp generator, replace, 9-45
- High stow, M901A1, replace, 24-122
- Launch tube stowage, M901A1, replace, 24-271
- Mortar base stowage, M1064, replace, 24-254.1
- Mortar base stowage, M106A2, replace, 24-255
- Mount, filter switch, M13 NBC, M577A2, 39-21
- Mount, filter switch, M3 NBC, M577A2, replace, 39-23
- Oilcan, replace, 24-237
- Ramp, M981A1, M1064, replace, 25-39

Brackets:

- And hoses, M14 NBC, M113A2 ambulance, replace, 39-90
- And hoses, M8A3 NBC, M577A2, replace, 39-31
- And hoses, M8A3 NBC, M10652, M125A2, replace, 39-36
- And switch assembly, cables, M8A3 NBC, M577A2, replace, 39-27
- Heater control box M1068 replace, 24-284
- Intercom M1068 replace, 24-284
- Kit mounting, replace, 44-8
- Mortar base bridge, and bumpers, M106A2, replace, 24-256
- Mortar base bridge, M125A2, replace, 24-258
- Muffler and, replace, 7-20
- Rifle, replace, 24-238
- Tripod stowage, M901A1, replace, 24-272
- Windshield and, replace, 30-1.

Brake:

- Assembly, commander's cupola, replace, 24-82
- Differential, adjustment, 21-18
- Disk, pivot steer, replace, 23-71
- Levers, differential steering, replace, 23-20
- Locking pawl, adjust, 23-4
- Steering, adjust, 23-2

Breather collector can and hose, crankcase, replace, 4-11

Bulkhead connection:

- Fuel pump to, hose, replace, 31-7
- Fuel pump to, hose, M106A2, M125A2, replace, 32-21

Subject, Page

B (cont)

Bulkhead connection (cont):

- Fuel pump to, hose, M1068, replace, 29-36
- Ramp control valve to, tube, replace, 28-22
- To heater fuel inlet hose, replace tube 32-23
- To heater hoses for the equipment heater, M577A2, replace, 31-8
- To heater tube, M106A2, M1064, M125A2, replace, 29-33
- To heater tube, M113A2, M1059, replace, 29-24
- To heater tube, M577A2, M1068, replace, 29-40
- Tube, to heater, M981, replace, 29-26

Buzzer:

- Admittance and switch, M577A2, replace, 12-72
- Admittance/right rear utility outlet works improperly, M577A2, 3-122

C

Cable:

- Air compressor, electrical assembly, M1059, replace, 40-13
- And switch assembly, M8A3/M14 NBC, M113A2, M1059A2, replace, 39-95
- And switch assembly, M8A3 NBC, M106A2, M125A2, replace, 39-43
- Alarm, M113A2, replace, 44-6
- Artillery communication:
 - Inside, M577A2, replace 37-5
- Assembly, Repair, 14-9
- Battery, M113A2, replace, 44-6
- Detector, M113A2, replace, 44-5
- Fuel shutoff, replace, 23-44
- Power, repair, M577A2, M1068 14-11
- Reel holder assembly, M1064, repair, 24-208.3
- Reel holder assembly, M1064, replace, 24-208.2
- Speedometer, and adapter, replace, 11-17
- Speedometer, repair, 11-19
- Switch assembly, brackets, M8A3 NBC, M577A2, replace, 39-27
- Tachometer and adapter, replace, 11-14
- Tube, external, replace, 42-8

Cap, filler, and strainer parts:

- Replace, M1059, M113A2, M577A2, M901A2, 6-8

Subject, Page

C (cont)

Cap, filler, and strainer parts (cont):
 Replace, M125A2, M106A2, 6-78
 Replace, M981, M1064, 6-30
 Capstan kit, 34-1
 Cargo hatch:
 Cover, replace, 24-113
 Door hook and bumpers, M113A2, M901A1,
 M1059, replace, 24-105
 Interior latch, replace, 24-101
 Latch, M901A1, repair, 24-115
 Support, M901A1, replace, 24-116
 Carrier:
 Assembly:
 Drive sprocket and cushions, replace, 22-30
 Does not move in any shift lever position,
 3-177
 Does not pivot, 3-179
 Chain assembly:
 Repair, M113A2, 36-3
 Replace, M113A2, 36-2
 Charging system malfunctions, 3-55
 Chart, dataplate, stencil, marker and decal:
 M106A2, M125A2, 24-237
 M113A2, 24-219
 M577A2, 24-223
 Chart, maintenance allocation, B-1
 Chemical agent auto alarm:
 Malfunctions, 3-233
 System schematic, 3-236
 Chemical agent wiring harness, M113A2,
 replace, 44-6
 Circuit breaker:
 Dome light, M577A2, M1068, replace, 12-70
 Generator/regulator, 100 amp generator,
 replace, 9-42
 Replace, 11-4
 Circuit breakers:
 Bilge pump, replace, 16-12
 Utility, rear, M577A2, M1068, replace, 17-11
 Circuit 6 lead, all except M577A2, M1068,
 replace, 13-13
 Clamps, tent and, M577A2, replace, 24-181
 Clean radiator, 8-7
 Combat filler cover and lock:
 Replace coolant, 3-33
 Replace fuel, M113A2, M1059, M577A2,
 M901A1, 6-7
 Replace fuel, M981, M1064, 6-29
 Commander's:
 Cupola:

Subject, Page

C (cont)

Commander's (cont.):
 Cupola (cont) :
 Armor shields, M113A2, M125A2, M106A2,
 M1064, M1059, replace, 38-2
 Azimuth lock, replace, 24-83
 Brake assembly, replace, 24-82
 Cover, M113A2, M106A2, M125A2, replace,
 24-82
 Cushioning pad and handle, M113A2,
 M106A2, M125A2, M1064, replace, 24-78
 Hatch latch and bumper, M113A2,
 M106A2, M1064, M125A2, replace, 24-88
 Interior latch, M113A2, M106A2, M125A2,
 M1064, M1059, replace, 24-84
 Machine gun mount, M113A2, M106A2,
 M125A2, M1064, M1059, replace, 24-90
 Machine gun mount stops, M1059, replace,
 24-93
 Hatch:
 Cover, M577A2, M1068, replace, 24-97
 Cushioning pad and handle, M577A2,
 M1068, replace, 24-95
 Hatch hook and bumper, M1068, M577A2,
 replace, 24-99
 Interior latch, M1068, M577A2, replace,
 24-96
 Jump seat, replace, 24-151
 Platform:
 And post, M577A2, M1068, repair, 24-157
 And post M577A2, M1068, replace, 24-157
 Repair, 24-153
 Replace, 24-153
 Seat, M1068, :
 Repair, 24-244.2
 Replace, 24-244.1
 Seat, observation periscope, M901A1, replace,
 24-161
 Seat and post:
 Bracket, M8A3/M3 NBC, M106A2,
 M125A2, replace, 39-48
 Repair, M113A2, M106A2, M125A2,
 M1064, 24-145
 Replace, 24-140
 Replace, M106A2, M125A2, M1064, 24-142
 Vision blocks and seals:
 Replace, all except M106A2, 24-79
 Common tools and supplements and special
 tools/fixtures list, D-1
 Compartment:
 Blower, M577A2, M1068, replace, 17-15

Subject, Page

C (cont)

Compartment (cont):
 Fuel, drain, M125A2, M106A2, 6-77
 Fuel, drain, M1068, 6-50
 Fuel access cover and drain plug:
 Fuel access cover M1068, replace, 6-57
 Replace, M125A2, M106A2, 6-79
 Ventilator, rear, air, replace, 24-117
 Compressor assembly, air, M1059, replace, 40-19
 Control box:
 Engine coolant heater:
 Repair, 32-42
 Replace, 32-42
 Heater, M3 NBC, M106A2, M125A2, replace, 39-57
 Heater, M3 NBC, M577A2, replace, 39-25
 Heater, M3 NBC, M1068, replace, 39-70
 Personnel heater:
 Repair, 29-43
 Replace, 29-42
 Control linkage, trim vane:
 Repair, 24-13
 Replace, 24-14
 Control panel to adapter access plate electrical cable assembly, M1059, 40-16
 Control valve, fire extinguisher and external handle, replace, 42-5
 Conversion formula, use of torque wrench adapters and the, 2-29
 Cooling system:
 Drain, 8-3
 Flow diagram, 8-2
 Hoses and fittings, all except M106A2, M125A2, 32-34
 Hoses and fittings, M106A2, M125A2, replace, 32-27
 Pump elbow hose and tube, radiator outlet elbow to, replace, 8-14
 Pump, engine, replace, 8-11
 Pump to coolant heater wiring harness, replace, 32-43
 Tube, deaeration elbow-to-radiator elbow inlet, replace, 8-12
 Coolant heater:
 Control box:
 Repair, 32-42
 Replace, 32-42
 Exhaust elbow and pipes, replace, 32-41
 Fuel pump:

Subject, Page

C (cont)

Coolant heater (cont):
 Fuel pump (cont):
 Replace, M113A2, M901A1, M1059, 32-12
 Replace, M106A2, M125A2, 32-14
 Replace, M577A2, M1068, 32-16
 Malfunctions, 3-217
 Pump, replace, 32-51
 Fuel pump to bulkhead connection:
 Replace, M113A2, M1059, M901A1, 32-18
 Hose, replace, M577A2, M1068, 32-20
 Hose, replace, M106A2, M125A2, 32-21
 Replace, 32-49
 System, engine, drain and fill, 32-10
 Coolant heater and pump unit, replace, 32-45
 Coolant pump, engine, idler pulley/belts, replace, 8-9
 Coolant system:
 Drain, 8-3
 Fill, 8-5
 Coolant temperature malfunctions, 3-144
 Engine heater kit M1068, 32-1
 Cooling fan assembly, replace, 13-44
 Cover:
 Antenna, replace, 24-241
 Access:
 Battery, M577A2, remove/install, 13-6
 Battery, M1068, remove/install, 13-16
 Battery, and leads, M113A2, M901A1, M1059, replace, 13-3
 Fan drive pulley, and, replace, 8-41
 Fuel compartment, M125A2, M106A2, replace, 6-79
 Fuel tank, M577A2, M1068, replace, 6-73
 Fuel tank, and drain plugs, M981, M1064, replace, 6-31
 Hull, front, replace, 24-24
 Power plant, bottom, replace, 24-32
 Air cleaner, replace, 7-5
 Battery box, M113A2, M901A1, M1059, repair, 13-20
 Cargo hatch, replace, M113A2, M901A1, M1059, 24-103
 Combat, filler and lock:
 Replace, M113A2, M1059, M577A2, M901A1, 6-7
 Replace, M981, M1064, 6-29
 Replace, 8-33
 Commander's cupola, M113A2, M106A2, M1064 M125A2, replace, 24-86

Subject, Page

C (cont)

Cover (cont):
 Commander's hatch, M577A2, M1068
 replace, 24-97
 Telepost and, replace, 17-8
 Cover and lock:
 Filler, combat, M113A2, M1059, M577A2,
 M901A1, replace, 6-7
 Filler, combat, M981, M1064, replace, 6-29
 Filler, combat, replace, 8-33
 Track shroud and, 12 inch (30 CM), replace,
 22-2
 Crank, engine does not, 3-15
 Crankcase, breather collector can and hose,
 replace, 4-11
 Cranks slowly, engine, 3-25
 Crew seat, M901A1, replace, 24-169
 Cross-shaft links:
 Differential, replace, 23-19
 Steering levers, replace, 23-14
 Cross-shafts and bearings:
 Differential, replace, 23-16
 Steering levers, replace, 23-10
 Curtain and frame, blackout, M577A2, M1068,
 replace, 24-171
 Cushion base, low stow, M901A1, replace,
 24-121
 Cushion rope, mortar rotation, M106A2, replace,
 24-254
 Cushioning pad, replace, 24-236
 Cylinder:
 Breather hose, ramp, M106A2, M1064,
 M125A2, replace, 28-92
 Breather hose, ramp, all except M106A2,
 M1064, M125A2, replace, 28-91
 Discharge tubes, replace, 42-11
 Suspension lockout, replace, 28-72
 Cylinder and mount, fire extinguisher, replace,
 42-13
 Cylinder head fuel return tube and hose, left,
 replace, 6-118

D

Data, equipment description and, 1-12
 Data panel assembly (M1068 ONLY), replace
 Curbside, 40.1-4
 Roadside, 40.1-5
 Dataplates, stencils, markers, and decals,
 replace, 24-217

Subject, Page

D (cont)

Dataplates, stencils, markers, and decals chart:
 M106A2, M125A2, 24-227
 M113A2, 24-219
 M577A2, 24-219
 M1068, 24-226.6
 Deaeration elbow, thermostat, housing and,
 replace, 8-15
 Deaeration elbow to radiator inlet elbow coolant
 tube, replace, 8-12
 Deaeration hoses, auxiliary tank, replace, 8-32
 Description and data, equipment, 1-12
 Description of major components, location and,
 1-12
 Destruction of army material to prevent enemy
 use, 1-8
 Diagram:
 Coolant flow, 8-2
 Differential oil flow, 21-1
 Engine oil flow, 4-1
 Fuel flow, M113A2, M125A2, M106A2, 6-1
 Fuel flow, M577A2, M1068, 6-2
 Fuel flow, M981, M1064, with external fuel
 tanks, 6-3
 Hydraulic fluid flow:
 All, 28-2
 Power train/steering/brakes/gear
 selection/throttle, 3-181
 Transmission oil flow, 18-2
 Wiring:
 M106A2, M125A2, FO-4
 M113A2, FO-1, FO-2
 M577A2, FO-3
 M901A1, FO-6
 M1064, FO-8
 M1068, FO-9 thru FO-11
 Differential:
 Brake adjustment, replace, 21-18
 Cross-shafts and bearings, replace, 23-16
 Cross-shaft links, replace, 23-19
 Dipstick and breather, oil level, replace, 21-9
 High oil temperature indicator comes on,
 3-68
 High oil temperature, switch, replace, 15-4
 Hose and fittings:
 Differential-to-oil-cooler, replace, 21-14
 Gearbox-to-differential, replace, 21-12
 Oil filter-to-pump, replace, 21-16
 Oil pump-to-differential, replace, 21-10
 Mounts, replace, 21-20

Subject, Page

D (cont)

Differential (cont):
 Oil filter and fittings, replace, 21-6
 Oil filter element, replace, 21-8
 Oil flow diagram, 21-1
 Oil high temperature indicator malfunctions, 3-159
 Pump, oil, replace, 21-2
 Shaft, to transmission, replace, 20-2
 Steering brake levers, replace, 23-20
 Switch lead, replace, 15-5
 Dipstick:
 Differential oil level, and breather, replace, 21-9
 Final drive filler tube and, replace, 20-12
 Transfer gearcase oil level dipstick, tube and guide, replace, 19-3
 Distribution box:
 Assembly:
 Replace, 100 amp generator, M113A2, M106A2, M125A2, M1064, M1059, 12-44
 Replace, 100 amp generator, M577A2, 12-28
 Replace, 100 amp generator, M901A1, 12-32
 Replace, 200 amp generator, M113A2, M125A2, M106A2, 12-48
 Replace, 200 amp generator, M577A2, M1068, 2-23
 Replace, 200 amp generator, M901A1, 12-52
 Master switch to, wire assembly:
 Circuit 49 lead, all except M577A2, M1068, replace, 9-26
 Circuit 49 lead, M577A2, M1068, replace, 9-49
 Repair, M113A2, 44-4
 Replace, M113A2, 44-2
 Dome light:
 And mount, repair, M577A2, M1068, 12-65
 Bypass switch, M577A2, M1068, replace, 12-71
 Circuit breaker, M577A2, M1068, replace, 12-70
 Malfunction, M577A2, 3-117
 Repair, all except M577A2, M1068, 12-61
 Replace, all except M577A2, M1068, 12-60
 Replace, M577A2, M1068, 12-64
 Switch, front, M577A2, M1068, replace, 12-68

Subject, Page

D (cont)

Dome light (cont):
 Switch, rear, M577A2, M1068, replace, 12-69
 Work improperly, 3-110
 Door:
 Handle stop, interior, M106A2, M125A2, replace, 33-2
 Handle, and release, interior, M106A2, M125A2, replace, 33-3
 Power plant door:
 Combat lock, replace, 24-19
 Repair, 24-22
 Replace, 24-21
 Radiator access:
 Replace, 8-28
 Seals and fasteners, replace, 8-25
 Seal, ramp, replace, 25-36
 Drain:
 Cooling system, 8-3
 Fuel tank, M113A2, M901A1, M1059, 6-5
 Fuel tanks, drain M577A2, M1068, 6-50
 Fuel tanks, M981, M1064, 6-28
 Drain cap and sight gage, replace, 8-42
 Drain plugs, M981A, M1064, replace, 25-41
 Drive:
 Final, replace, 20-9
 Sprockets, carrier assembly, and cushions, replace, 22-32
 Driver's:
 Compartment floor plates, replace, 24-36
 Footrest, new configuration, replace, 24-134
 Power plant access panel, replace, 24-25
 Seat, all models, replace, 24-127
 Seat, repair, 24-129
 Seat mount, new configuration, repair, 24-132
 Seat mount, old configuration, replace, 24-131
 Seat post assembly, new configuration, repair, 24-135
 Seat post assembly, new configuration, replace, 24-135
 Driver's hatch:
 Cover and exterior lock, all except M901A1, replace, 24-62
 Cushioning pad, replace, 24-51
 Hatch latch and bumper, all except M901A1, replace, 24-64
 Interior lock and latch, replace, 24-55
 Periscope guard and quick release assembly, repair, 24-57

Subject, Page

D (cont)

- Driver's hatch (cont):
 - Repair, driver's hatch, M901A1, 24-67
 - Vision block locks and seals, all except M106A2, replace, 24-52
- Drum:
 - Adapter, M113A2, M1059, replace, 34-3
 - Assembly, M113A2, M1059, replace, 34-2
- Duct:
 - Heater, repair, 29-49
 - Heater, and hoses, replace, 28-47

E

- Elbow:
 - Coolant heater exhaust, and pipes, replace, 32-41
 - Deaeration, to radiator inlet elbow coolant tube, replace, 8-12
 - Engine air inlet to air box heater hoses, replace, 6-112
 - Radiator outlet, to coolant pump elbow hose and tube, replace, 8-14
- Electrical cable assembly, fog oil pump, M1059, replace, 40-14
- Electrical/communication equipment, M1068 ONLY:
 - Boxes, replace:
 - AC power extension A6, 40.1-48
 - AC power extension A7, 40.1-12
 - DC power extension A8, 40.1-13
 - DC power extension A9, 40.1-48
 - Data panel, curbside, 40.1-4
 - Data panel, roadside, 40.1-5
 - External communication A11, 40.1-18
 - LAN ground A15, 40.1-15
 - Power distribution A3, 40.1-49
 - Power entry A4, 40.1-54
 - Power entry panel, 40.1-24
 - Signal patch panel A10, 40.1-21
 - Switch, 40.1-14
 - Tent interface panel A5, 40.1-46
 - UPS power extension A16, A17, 40.1-8
 - Cables, replace:
 - AC inverter W5, 40.1-62
 - AC power extension W7, 40.1-66
 - AC power extension W8, 40.1-68
 - AC light W11, 40.1-75
 - DC battery W4, 40.1-60
 - DC power extension W10, 40.1-73

Subject, Page

E (cont)

- Electrical/communication equipment, (cont) M1068 ONLY (cont):
 - Cables, replace (cont):
 - DC inverter W6, 40.1-64
 - Ground strap W12 40.1-77
 - LAN A or B W103/104, 40.1-94
 - Power distribution W3, 40.1-58
 - Power extension W50, 40.1-92
 - Remote cascade W15, 40.1-26
 - Single point LAN W40, 40.1-86
 - W32, 40.1-78
 - W35, W28, and adapter, 40.1-82
 - W38, W29, and adapter, 40.1-84
 - W41, W42, and W43, 40.1-88
 - W45, 40.1-90
 - W124, 40.1-97
 - W126, 40.1-100
 - Inverter housing A2:
 - Terminal blocks TB1 and TB2, replace, 40.1-28.1
 - Fluorescent light, replace, 40.1-56
 - Power control enclosure A1:
 - Faceplate and bracket, repair, 40.1-33
 - Indicators, replace, 40.1-29
 - Meters, AC and DC, replace, 40.1-29
 - Repair, 40.1-33
 - Replace, 40.1-41
 - Electrical systems (M1068 ONLY), 2-18.1
 - Electrical system schematic, 3-172
 - Electrical wiring diagram:
 - M106A2, M125A2, FO-4
 - M113A2, FO-1, FO-2
 - M577A2, FO-3
 - M901A1, FO-6
 - M1064, FO-8
 - M1068, FO-9 thru FO-11
 - Element:
 - Air cleaner, replace, 7-2
 - Engine oil filter and parts, replace, 4-3
 - Fuel filter, replace, 6-128
 - Engine:
 - Air inlet elbow to air box heater hoses, 6-112
 - Coolant heater kit, 32-1
 - Coolant pump, replace, 8-11
 - Coolant pump, thermostat housing to, replace, 8-18
 - Coolant pump idler pulley and belts, replace, 8-9

Subject, Page

E (cont)

Engine (cont):

- Coolant temperature switch, replace, 15-3
- Cranks but will not start, 3-30
- Cranks but will not start below 40 degrees (air box heater is used), 3-34
- Cranks slowly, 3-25
- Does not crank, 3-15
- Fuel pump, replace, 6-121
- Fuel system diagram, 6-101
- Left to right engine cylinder head fuel hose, replace, 6-110
- Mount, front, replace, 4-2
- oil:
 - Filler cap and tube, replace, 4-13
 - Filter assembly, replace, 4-5
 - Filter bracket, hoses, and fittings, replace, 4-7
 - Filter element and parts, replace, 4-3
 - Flow diagram, 4-1
 - Gage rod and guide, replace, 4-15
 - Low pressure indicator fails to go off after engine starts, 3-50
 - Low pressure indicator malfunctions, 3-148
 - Low pressure switch, replace, 15-2
- Overcools, 3-14
- Overheats, 3-10
- Power disconnect, replace, 23-57
- Runs rough, stalls, or does not put out full power, 3-44
- Schematic:
 - Charging system, 100 amp, 3-65
 - Charging system, 200 amp, 3-66
 - Charging system, 200 amp, M981, 3-67
 - Fuel system, 3-52
- Start switch, replace, 11-10
- Engine coolant heater:
 - Control box, replace/repair, 32-42
 - Heater system, drain and fill, 32-10
- Engine fuel:
 - Flow diagram, M981, M1064 with external fuel tanks, 6-3
 - System diagram, 6-101
 - System diagram, M113A2, M125A2, M106A2, with inside tank or compartment, 6-1
- Equipment:
 - Description and data, 1-12
 - Improvement recommendations (EIR), reporting of, 1-11

Subject, Page

E (cont)

Equipment (cont):

- Rack, right, M1068, 40.1-6 special, 2-7
- Stowage shelf, M901A1, replace, 24-180
- Equipment heater:
 - Control box, M577A2, replace, 31-11
 - Fuel pump to bulkhead connection hose, M577A2, replace, 31-7
- Exhaust, coolant heater, elbow and pipes, replace, 32-41
- Exhaust pipes, replace, 7-16
- Expendable/durable supplies and materials list, C-1
- Exterior catches and bumpers, mortar hatch, M106A2, M1064, M125A2, replace, 24-109
- Eye, lifting, replace, 24-2

F

Face mask:

- Connector assembly, orifice, NBC equipment, replace, 39-100
- Gas filter, ventilated, M25/M25A1, replace, 39-101
- Heater, ventilated, M25/M25A1, replace, 39-102
- Hose assembly, ventilated, M25/M25A1, replace, 39-99
- Facsimile machine mount, replace, 40.1-2
- Fan assembly, cooling, replace, 8-14
- Fan drive:
 - Adjustable idler and pulley, replace, 8-39
 - Belts, replace, 8-35
 - Fixed idler and pulley, replace, 8-37
 - Pulley and access cover, replace, 8-41
 - Shaft, pulley, bearing, and housing, 8-46
- Filler:
 - Cap and strainer parts:
 - Replace, M981, M1064, 6-30
 - Replace, M1059, M113A2, M577A2, M901A1, 6-8
 - Replace, M125A2, M106A2, 6-78
 - Cap and tube, oil, replace, 4-13
 - Combat cover and lock:
 - Replace, 8-33
 - Replace, M113A2, M1059, M577A2, M901A1, 6-7
 - Replace, M981, M1064, 6-29
- Flange:

Subject, Page

F (cont)

Filler (cont):

Fuel tank, filler flange, M577A2, M1068,
replace, 6-59

Strainer parts, replace, M577A2, M1068,
6-52

Tube and dipstick, final drive, replace, 20-12

Tube, transmission vent and, replace, 18-6

Filter:

And drain, transmission oil, replace, 18-8

And hoses, M13 NBC, M1068, replace, 39-61

And hoses, M13 NBC, M577A2, replace,
39-6

Bracket, hoses, and fittings, engine oil,
replace, 4-7

Differential and fittings, oil, replace, 21-6

Element, oil, differential, replace, 21-8

Element, engine oil and parts, replace, 4-3

Engine oil, assembly, replace, 4-5

Fuel:

Primary, replace, 6-123

Secondary, replace, 6-125

Gas, VFM, M25/M25A1, replace, 39-101

Secondary, to left cylinder head fuel hose,
6-108

Switch, mount bracket, M13 NBC, M577A2,
replace, 39-21

Switch, mount bracket, M3 NBC, M577A2,
replace, 39-23

Switch assembly, M3 NBC, M106A2,
M125A2, replace, 39-49

Switch assembly, M3 NBC, M113A2
ambulance, replace, 39-83

Final drive:

Filler tube and dipstick, replace, 20-12

Hull drain plugs, replace, 24-34

Pinion oil seal, replace, 20-11

Replace, 20-9

Shaft:

Left, replace, 20-5

Right, replace, 20-7

Fire extinguisher:

Control valve and external handle, replace,
42-5

Cylinder and mount, replace, 42-13

Cylinder discharge tubes, replace, 42-11

External cable tube, replace, 42-8

External handle shield:

Replace, M577A2, M1068, 42-3

Replace, M106A2, M1064, M125A2, 42-4

Subject, Page

F (cont)

Fire extinguisher (cont):

Replace, M113A2, M901A1, M1059, 42-2

Mount, M1059, replace, 42-16

Mount, portable, replace, 42-15

Flame detector switch:

Replace, 32-3

Repair, 32-5

Floor plates:

Driver's compartment, replace, 24-36

Rear compartment, M113A2, M577A2,
replace 24-37

Rear compartment, M1068, replace 24-44.1

Replace, M1059, 24-42

Replace, M106A2, M125A2, M1064, 24-38

Replace, M901A1, 24-45

Fog oil pump:

Assembly, replace, 40-21

Electrical cable assembly, replace, 40-14

Fog oil tank:

Cover assembly, quick disconnect to adapter
access plate hose, M1059, replace, 40-33

Quick disconnect to adapter access plate hose,
M1059, replace, 40-31

Replace, M1059, 40-2

Footrest:

Driver's, new configuration, replace, 24-134

Frame:

And air purifier, M8A3/M14 NBC, M113A2,
replace, 39-93

And air purifier, M8A3/M3 NBC, M106A2,
M125A2, replace, 39-46

And air purifier, M13, M1068, replace, 39-59

And air purifier, M8A3/M13, M577A3,
replace, 39-32

Mounts, tent and, M577A2, replace, 24-183

Driver's, new configuration, replace, 24-134

Forms, records and reports, maintenance, 1-8

Front engine mount, replace, 4-2

Fuel:

Compartment, access cover:

Replace, M125A2, M106A2, 6-79

Compartment, drain, M125A2, M106A2, 6-77

Compartment-to-fuel pump:

Hose, fuel tank to fuel pump, M577A2,
M1068, replace, 29-36

Hose, fuel pump to bulkhead connection,
M577A2, M1068, replace, 29-38

Tube, M106A2 and M125A2, replace, 29-29

Engine, system diagram, 6-101

Subject, Page

F (cont)

Fuel (cont) :

- Shutoff cable, replace, 23-44
- Filter:
 - Elements, replace, 6-128
 - Mounting bracket, replace, 6-130
 - Mounting bracket, M577A2, M1068 with 200 amp gen, replace, 9-45
 - Primary, replace, 6-123
 - Secondary, replace, 6-125
- Flow diagram:
 - M577A2, M1068, 6-2
 - M981, M1064 with external fuel tanks, 6-3
 - M113A2, M125A2, M106A2, with inside tank or compartment, 6-1
- Hose, and fuel return tube, left cylinder head, replace, 6-118
- Hose, bulkhead connection to primary fuel filter, replace, 6-102
- Hose, primary fuel filter to engine fuel pump, replace, 6-104
- Hose, secondary fuel filter, engine fuel pump to, replace, 6-106
- Hoses, tubes and fittings:
 - Auxiliary generator, M1068, 28.1-4, 28.1-7, 28.1-10
 - Compartment-to-bulkhead, M125A2, M106A2, replace, 6-81
 - Fuel return, M981, replace, 6-44
 - Fuel return, M1064, replace, 6-48.9
 - Fuel return, M577A2, M1068, replace, 6-66
 - Internal, M125A2, M106A2, replace, 6-85
 - Supply, M577A2, M1068, replace, 6-60
 - Supply, M981, replace, 6-39
 - Supply, M1064, replace, 6-48.3
 - Tank-to-bulkhead, M113A2, M1059, M901A1, replace, 6-23
- Level indicator malfunctions, 3-134
- Lines, and guards, smoke generator, M1059, replace, 40-25
- Quantity selector, switch, M577A2, M1068, replace, 17-17
- Quantity transmitter:
 - Replace, M125A2, M106A2, 6-80
 - Replace, M113A2, M901A1, M1059, 6-9
 - Replace, M981, M1064, 6-32
 - Replace, M577A2, M1068, 6-54
 - Select switch to gage lead, M981 and M1064, replace, 11-20
- Tank:

Subject, Page

F (cont)

Fuel (cont):

- Plug, smoke generator, M1059, replace, 40-23
- Repair, temporary, M113A2, M1059, M901A1, M577A2, 6-21
- Replace, M577A2, M1068, 6-73
- Replace, M113A2, M901A1, M1059, 6-11
- Replace, M981, M1064, 6-34
- Tank access covers:
 - And drain plugs, M981, M1064, replace, 6-31
 - Replace, M577A2, M1068, 6-57
- Tank filler flange, M577A2, M1068, replace, 6-59
- Fuel filter:
 - Elements, replace, 6-128
 - Hose, secondary fuel, to engine fuel pump, replace, 6-106
 - Primary, to engine fuel pump hose, replace, 6-104
 - Secondary, to left cylinder head fuel hose, replace, 6-108
- Fuel level indicator malfunctions, 3-134
- Fuel lines, air from personnel heater, bleed, 29-8
- Fuel lines and guards, smoke generator, M1059, replace, 40-25
- Fuel pump:
 - Engine, replace, 6-121
 - Engine coolant heater:
 - Replace, M106A2, M125A2, 32-14
 - Replace, M113A2, M901A1, M1059, 32-12
 - Replace, M577A2, M1068, 32-16
 - Equipment heater to bulkhead connection hose, M577A2, replace, 31-7,
 - Heater, replace and service, M577A2, 31-16
- Hose:
 - To bulkhead connection, replace, 31-7
 - To bulkhead connection, M106A2, M1064, M125A2, replace, 29-31
 - To bulkhead connection, M577A2, M1068, replace, 29-38
 - To heater shutoff valve, M1064, replace, 29-30.1
- Personnel heater:
 - Replace, M106A2, M1064, M125A2, 29-11
 - Replace, M113A2, M1059, 29-8
 - Replace, M577A2, M1068, 29-13
 - Service, 29-2
- Fuel return:
 - Air box:

Subject, Page

F (cont)

Fuel return (cont):
 Heater to fuel return tee and hose, 6-115
 Left cylinder head return tube and hose,
 6-118
 Auxiliary generator, M1068, 28.1-10
 Hoses, tubes, and fittings:
 Replace, M981, 6-44
 Replace, M1064, 6-48.9
 Replace, M577A2, M1068, 6-66
 Fuel shutoff cable:
 Adjust, 23-46
 Replace, 23-44
 Fuel tank:
 To fuel pump hose:
 Hoses, tubes and fittings, internal, M1068,
 6-4
 Filler, cover and lock, M1068, 6-7
 Filler cap and strainer parts M1068, 6-8
 Repair tank M1068, 6-21
 Quantity transmitter M1068, 6-57
 Replace, M113A2, M901A1, M1059, 29-15
 Fuze rack, vertical, replace, M106A2, 24-186

G

Gages, instrument panel, replace, 11-11
 General:
 Information, 1-1
 Maintenance instructions, 2-27
 Generator:
 Adjustment linkage:
 100 amp, replace, 9-31
 200 amp, replace, 9-34
 Auxiliary, M1068 ONLY:
 Fuel return hose, 28.1-10
 Fuel shutoff valve, replace, 28.1-2
 Fuel supply hoses, replace, 28.1-4, 28.1-7
 Circuit breaker, generator/regulator, 100 amp,
 replace, 9-42
 Drive belts:
 Replace, 100 amp, 9-29
 Replace, 200 amp, 9-47
 Electrical cable assembly, adapter access plate
 to, M1059, replace, 40-13
 Field switch, replace, 9-44
 Set enclosure, M577A2, M1068, replace,
 24-118 and 2-54
 Grenade launcher wiring harness, smoke,
 replace, 27-3

Subject, Page

G (cont)

Grenade stowage box, M106A2, M1064,
 M125A2, replace, 24-250
 Grill, power plant, raise/lower, 5-2
 Grill, power plant, remove and install, 5-11
 Ground lead, horn and, replace, 12-2
 Ground leads, starter, replace, 10-4
 Guard:
 Antenna, replace, 24-240
 Headlight, replace, 12-11
 Plate, and base, M113A2, M1059, M901A1,
 replace, 27-2
 Guards, stop light-tail light and, M981, M1064,
 replace, 12-57
 Gun:
 Mount adapter assembly, replace, 38-5
 Pintle socket, rear, M113A2, replace, 38-6
 Traverse restrictor, replace, 38-7

H

Hand throttle, replace, 23-42
 Handle:
 Commander's cupola cushioning pad and,
 Replace, M113A2, M106A2, M125A2,
 M1064, 24-78
 Replace, M577A2, M1068, 24-95
 Fire extinguisher control valve and external,
 replace, 42-5
 Interior door, and release, M106A2, M125A2,
 replace, 36-2
 Interior door, stop, M106A2, M125A2,
 replace, 36-3
 Shield, external:
 Replace, M106A2, M1064, M125A2, 42-4
 Replace, M113A2, M901A1, M1059, 42-2
 Replace, M577A2, M1068, 42-3
 Handles and links, pivot steer, replace, 23-62
 Handling techniques, 2-27
 Harness:
 Power, cable, M3 NBC, M106A2, M125A2,
 replace, 39-54
 Harness, trailer, replace 17-2
 Cascade remote cable, M1068, replace,
 40.1-26
 Hatch:
 Cargo, door, M113A2, M901A1, M1059,
 replace, 24-103
 Cargo, latch, M901A1, repair, 24-115
 Cargo support, M901A1, replace, 24-116

Subject, Page

H (cont)

Hatch (cont):

- Cover M1068, commander, replace, 24-97
- Covers, mortar, M106A2, M1064, M125A2, replace, 24-113
- Cushioning pad, driver's, replace, 24-51
- Cushioning pad and handle M1068 commander, replace, 24-95
- Hook and bumper M1068, commander, replace, 24-99
- Internal latch M1068, commander, replace, 24-96
- Driver's, M901A1, repair, 24-67
- Interior latch, cargo, replace, 24-101
- Interior lock and latch, driver's, replace, 24-55
- Vision block locks and seals, driver's:
 - Replace, all except M106A2 24-52
- Headlight:
 - Blackout:
 - Repair, 12-10
 - Replace, 12-9
 - Blackout marker:
 - Repair, 12-8
 - Replace, 12-7
 - Guard, replace, 12-11
 - High beam selector switch, replace, 12-77
 - Wiring harness, right, replace, 12-79
 - Service and infrared:
 - Repair, 12-5
 - Replace, 12-3
- Headlights:
 - Infrared, does not operate, 3-83
 - Service, do not operate, 3-78
- Heater:
 - Air box:
 - Air pump, replace, 6-133
 - And controllers, M3 NBC, M113A2 ambulance, replace, 39-86
 - And mounts, M13 NBC, M577A2, replace, 39-17
 - Ignition coil, replace, 6-132
 - Replace, 6-138
 - Solenoid valve, replace, 6-136
 - Wiring harness, replace, 6-140
 - Air intake and exhaust pipes:
 - Replace, M106A2, M1064, M125A2, 29-55
 - Replace, M106A2, M125A2, 29-53
 - Assembly:
 - Electronic equipment, replace, 31-16

Subject, Page

H (cont)

Heater (cont):

- Replace, 29-51
- Control box:
 - Electronic equipment, replace, 31-11
 - Engine coolant, repair, 32-42
 - Engine coolant kit M1068, 32-1
 - M3 NBC, M106A2, M125A2, replace, 39-57
 - M3 NBC, M1068, replace, 39-70
 - M3 NBC, M577A2, replace, 39-25
 - Personnel, repair, 29-43
 - Personnel, replace, 29-42
- Coolant:
 - Exhaust elbow and pipes, replace, 32-41
 - Heater malfunctions, 3-217
 - Pump, replace, 32-51
 - Pump, fuel M1068, replace, 32-16
 - Replace, 32-49
- Data, Stewart Warner, 31-1
- Duct:
 - Repair, 29-19
- Duct and hoses:
 - Replace, 29-47
- Fuel:
 - Inlet, hose, replace, 32-25
 - Lines, bleed air from compartment, 29-4
- Fuel pump:
 - Coolant, M106A2, M125A2, replace, 32-14
 - Coolant, M113A2, M901A1, M1059, replace, 32-12
 - Coolant, M577A2, M1068, replace, 32-16
- Replace fuel pump assembly:
 - M106A2, M1064, M125A2, 29-11
 - M113A2, M1059, 29-8
 - M577A2, M1068, 29-13
 - Tee connection to hose, M981, replace, 29-17
- Hose:
 - Fittings, M3 NBC, M113A2 ambulance, replace, 39-77
 - Fuel compartment to fuel pump, M577A2, M1068, replace, 29-36
 - Fuel pump to bulkhead connection, replace, 29-22
 - Fuel pump to bulkhead connection, M106A2, M1064, M125A2, replace, 29-31
 - Fuel tank to fuel pump, M113A2, M901A1, M1059, replace, 29-15
 - M3 NBC, M106A2, M125A2, replace, 39-51

Subject, Page

H (cont)

Heater (cont) :

- M13 NBC, M1068, replace, 39-65
- Tee connection to fuel pump, M981, replace, 29-17
- Malfunctions:
 - Coolant, 3-217
 - Personnel, 3-207
- M3 NBC, M106A2, M125A2, replace, 39-51
- Pump, coolant, replace, 32-51
- System, engine coolant, drain and fill, 32-10
- Tube to bulkhead connection:
 - Replace, M106A2, M1064, M125A2, 29-33
 - Replace, M113A2, M1059, 29-24
 - Replace, M577A2, M1068, 29-40
- VFM, M25/M25A1, replace, 39-102
- Wiring harness, M13 NBC, M577A2, replace, 39-3
- Wiring harness, M13 NBC, M1068, replace, 39-72
- Heater and pump unit, coolant, replace, 31-45
- Heater component maintenance, Stewart Warner Corp., 31-1
- High beam indicator light malfunctions, 3-140
- High stow bracket, M901A1, replace, 24-124
- High stow launcher support, M901A1, replace, 24-122
- Hook and bumper:
 - Cargo hatch, door, M113A2, M901A1, M1059, replace, 24-105
 - Commander's cupola, hatch latch, M113A2, M125A2, M1064, M106A2, replace, 24-88
 - Commander's hatch, M577A2, M1068, replace 24-99
 - Driver's hatch latch, all except M901A1, replace, 24-64
- Hook, towing, replace, 24-3
- Horizontal ammunition rack:
 - Repair, M1064, 24-190.3
 - Replace, M106A2, 24-191
 - Replace, M125A2, 24-189
 - Replace, M1064, 24-190.3
- Hooks and brackets, stowage, M113A2, replace, 35-3
- Horn:
 - Does not operate, 3-102
 - Switch, replace, 11-24
- Horn and ground lead, replace, 12-2
- Hose:
 - Air cleaner restriction indicator, replace, 7-9

Subject, Page

H (cont)

Hose (cont):

- Balance, replace, 8-24
- Breather, on ramp cylinder:
 - Replace, all except M106A2, M1064, M125A2, 28-91
 - Replace, M106A2, M1064, M125A2, 28-92
- Bulkhead connection to ramp cylinder, replace, 28-89
- Coolant heater fuel pump to bulkhead connection:
 - Replace, M106A2, M125A2, 32-21
 - Replace, M577A2, M1068, 32-20
- Differential:
 - Gearbox-to-differential, replace, 21-12
 - Oil filter-to-pump, replace, 21-16
 - Oil pump-to-differential, replace, 21-10
 - To oil cooler, replace, 21-14
- Equipment. heater fuel pump to bulkhead connection, M577A2, replace, 31-7
- Fuel compartment-to-fuel pump, M577A2, M1068, 29-36
- Fuel pump to bulkhead connection:
 - Replace, 29-19
 - Replace, M106A2, M1064, M125A2, 29-31
- Fuel pump to heater shutoff valve, M1064, 29-30.1
- Fuel tank to fuel pump:
 - Replace, M113A2, M901A1, M1059, 29-15
- Heater fuel inlet, replace, 32-25
- Oil cooler-to-transmission, and fittings, replace, 18-4
- Ramp pump:
 - To pressure release valve, replace, 28-9
- Relief valve tee to quick disconnect, replace, 28-11
- Shutoff valve to fuel pump, M577A2, replace, 31-5
- Smoke generator, breather assembly, M1059, replace, 40-5
- Trans-to-oil cooler, and fittings, replace, 18-2
- Hoses:
 - And brackets, M8A3 NBC, M577A2, replace, 39-30
 - And brackets, M8A3 NBC, M106A2, M125A2, replace, 39-36
 - And brackets, M113A2 ambulance, replace, 39-90
 - And filters, M13 NBC, M1068, replace, 39-61

Subject, Page

H (cont)

Hoses (cont):
 And filters, M13 NBC, M577A2, replace, 39-6
 Air cleaner, replace, 7-3
 Auxiliary tank deaeration, replace, 8-32
 Coolant:
 Fittings and, M113A2, M577A2, replace, 32-27
 Fittings and, M160A2, M125A2, replace, 32-34
 Pump elbow, and tube, to radiator outlet elbow, replace, 8-14
 Fittings and tubes:
 Air box, drain, replace, 4-9
 Compartment-to-bulkhead, M125A2, M106A2, replace, 6-81
 Fuel supply, replace, M577A2, M1068, 6-60
 Internal, M125A2, M106A2, replace, 6-85
 Pivot steer, brake, repair, 23-68
 Pivot steer, brake, replace, 23-68
 Return, M577A2, M1068, replace, 6-66
 Tank-to-bulkhead, M113A2, M901A1, M1059, replace, 6-23
 Vent, M577A2, M1068, replace, 6-70
 Heater duct and hoses:
 Replace, 29-47
 Heater, fittings, M3 NBC, M113A2 ambulance, replace, 39-77
 Heater, M13, M1068, replace, 39-65
 Housing:
 Air cleaner, replace, 7-7
 Thermostat and deaeration elbow, replace, 8-15
 Thermostat to engine coolant tube, replace, 8-18
 How to use this manual, vi
 Hub:
 Idler wheel, replace, 22-17
 Road wheel, replace, 22-9
 Hull drain plugs:
 Final drive, replace, 24-34
 Replace, 24-31
 Hull, front access cover, replace, 24-24
 Hull, welding, repair by, 26-1
 Hupp heater electronic equipment, 31-1
 Hydraulic fluid flow diagram:
 All, 28-2
 Hydraulic tank:
 Ramp pump to, strainer tube, replace, 28-7

Subject, Page

H (cont)

Hydraulic tank (cont):
 Repair, 28-17
 Replace, 28-17,
 Strainer, replace, 28-15
 I
 Identification, 2-27
 Idler, fan drive:
 Adjustable, and pulley, replace, 8-39
 Fixed, and pulley, replace, 8-37
 Idler pulley and belts, engine coolant pump, replace, 8-9
 Idler wheel:
 Arm assembly:
 Replace, 22-20
 Hub, replace, 22-17
 Replace, 22-16
 Igniter, replace, 32-7
 Ignition coil, air box heater, replace, 6-132
 Indicator:
 Air cleaner restriction, and hose, replace, 7-9
 Differential high oil temp, comes on, 3-68
 Engine oil low pressure, fails to go off after engine starts, 3-50
 Lights, panel lights and, replace, 11-5
 Transmission oil hi temp, comes on, 3-71
 Indicator malfunctions:
 Battery/generator, 3-143
 Coolant temperature, 3-144
 Differential oil hi temp, 3-159
 Engine oil low pressure, 3-148
 Fuel level, 3-134
 High beam light, 3-140
 Transmission oil hi temp, 3-153
 Infrared headlights:
 Does not operate, 3-83
 Service and, repair, 12-5
 Service and, replace, 12-3
 Infrared periscope works improperly, 3-112
 Infrared power supply:
 Assembly, replace, 12-134
 Shock mount brackets, replace, 12-136
 Inspection, 2-33
 Instrument panel:
 Gages, replace, 11-11
 Illumination lights malfunction, 3-107
 Mounts and ground lead, replace, 11-2
 On-off switches, replace, 11-7

Subject, Page

I (cont)

Instrument panel (cont):
 Tachometer, replace, 11-13
 Insulation and heat exchanger:
 Battery box, M113A2, M901A1, M1059,
 replace, 13-37
 Battery box, M577A2, M1068, replace, 13-35
 Battery drawer, M106A2, M1064, M125A2,
 replace, 13-32
 Integrated components, 2-8
 Integrated systems, 2-1
 Interior release mechanisms, mortar hatch,
 M106A2, M1064, M125A2, replace, 24-107

J

K

Kit:

Capstan, 34-1
 Litter, M113A2, 36-1
 Mounting brackets, M113A2, replace, 44-8

L

Latch:

Cargo hatch interior, replace, 24-101
 Commander's cupola interior, M113A2,
 M106A2, M125A2, M1064, M1059, replace,
 24-84
 Commander's hatch interior, M577A2,
 M1068, M471A1, replace, 24-97

Launch tube stowage bracket, M901A1, replace
 24-271

Launcher:

Smoke grenade, malfunction, 3-196
 High stow, support, M901A1, replace, 24-124

Lead:

Battery, M106A2, M1064, M125A2, replace,
 13-10
 Battery, M1068, replace, 13-6.1
 Battery, M577A2, replace, 13-7
 Battery ground, disconnect/connect, 13-2
 Circuit 6, all except M577A2, M1068,
 replace, 13-13
 Fuel select switch to gage, M981, M1064,
 replace, 11-20
 Horn and ground, replace, 12-2
 Instrument panel mounts and ground,
 replace, 11-2

Subject, Page

L (cont)

Lead assembly utility outlet, M577A2, M1068,
 replace 17-7
 Left table, M577A2, M1068, replace, 24-178
 Lifting eye, replace, 24-2
 Lifting eyebolt, cover, and plug, transfer
 gearcase, replace, 19-6
 Light:
 Blackout drive, does not operate, 3-75
 Blackout marker:
 Repair, 12-8
 Replace, 12-7
 Tail lights do not operate, and/or, 3-93
 Dome, all except M577A2, M1068:
 Repair, 12-61
 Replace, 12-60
 Dome, M577A2, M1068:
 Malfunction, 3-117
 Mount and, repair, 12-65
 Replace, 12-64
 Headlight high beam selector switch, replace,
 12-77
 Lead assembly, master switch panel to dome,
 M577A2, M1068, replace, 12-67
 Service tail, does not operate, 3-98
 Stop light-tail:
 And guards, M981, M1064, replace, 12-57
 Left, repair, 12-13
 Left, replace, 12-12
 Right, repair, 12-13
 Right, replace, 12-14
 Switch, main, replace, 11-9
 Tent assembly, M577A2, replace, 12-76
 Lights:
 Blackout marker, and/or tail lights, do not
 operate, 3-93
 Dome, work improperly, 3-110
 Fluorescent, M1068, replace, 40.1-56
 Front dome, M1068, replace, 12-68
 Front and/or rear bilge pump and/or, do not
 operate, 3-201
 Instrument panel illumination, malfunction,
 3-107
 Operate, no exterior, 3-73
 Panel and indicator, replace, 11-5
 Panel, replace, 11-22
 Rear dome, replace M1068, 12-69
 Service and/or blackout stop, malfunction,
 3-89
 Tail light, replace M1068, 24-276

Subject, Page

L (cont)

Lights (cont):
 Tent light, M577A2, replace, 12-76
 Trailer, do not operate, 3-100
 Warning panel, replace, 11-22
 Linkage:
 Accelerator:
 Upper, repair, 23-33
 Upper, replace, 23-31
 Accelerator and transmission throttle valve,
 adjust, 23-34
 Generator and adjustment:
 100 amp, replace, 9-31
 200 amp, replace, 9-34
 Pivot steer, adjust, 23-72
 Ramp:
 Replace, M113A2, M901A1, M1059, 25-7
 Replace, M577A2, M1068, 25-26
 Replace, M106A2, M1064, M125A2, 25-15
 Selector, range, replace, 23-55
 Transmission and lower accelerator:
 Repair, 23-29
 Replace, 23-25
 Litter kit, initial installation of, M113A2, 36-1
 Location and description of major components,
 1-12
 Lock:
 Commander's cupola azimuth, replace, 24-83
 Driver's hatch cover and exterior, all except
 M901A1, replace, 24-62
 Power plant door combat, replace, 24-19
 Ramp:
 Adjust, M113A2, M901A1, M1059, 25-2
 Adjust, M577A2, M1068, 25-19
 Adjust, M106A2, M1064, M125A2, 25-10
 Lock and latch, driver's hatch interior, replace,
 24-55
 Lock assembly and mount, rear armor shield
 mounting arm, replace, 38-10
 Lock lever and arms, ramp, replace, 25-5
 Lock lever and cable, ramp, M577A2, M1068,
 replace, 25-23
 Locking pawl, adjust brake, 23-4

M

Machine gun platform mount assembly, 7.62
 mm M60, M113A2, replace, 38-5
 Main light switch, replace, 11-9
 Maintenance:
 Allocation chart, B-1

Subject, Page

M (cont)

Maintenance (cont):
 Forms, records, and reports, 1-8
 Instructions, general, 2-27
 Preparation for, 2-27
 Malfunctions:
 Charging system, 3-55
 Coolant heater, 3-217
 Speedometer, 3-227
 Tachometer, 3-230
 Manual, how to use this, vi
 Map board, M577A2, replace, 24-247
 *Map board, M1068, replace, 24-248.1
 Map storage box, M1068:
 Repair, 24-248.3
 Replace, 24-248.2
 Marker light and/or tail lights do not operate,
 blackout, 3-93
 Markers, and decals, dataplates, stencils,
 replace, 24-217
 Master cylinder and hoses, pivot steer, replace,
 23-66
 Master switch panel lead assembly, to dome
 lights, M577A2, M1068, 12-67
 Master switch:
 Panel assembly:
 Early slave receptacle, all except M577A2,
 replace, 9-19
 Late slave receptacle, all except M577A2,
 M1068, replace, 9-16
 Replace, M577A2, 9-23
 Replace, 9-13
 Replace M1068, 9-22
 Master switch on indicator does not light, 3-129
 Master switch to distribution box wire assembly:
 Circuit 49 lead, all except M577A2, M1068,
 replace, 9-26
 Circuit 49 lead, M577A2, M1068, replace,
 9-49
 Materials list, expendable/durable supplies and,
 Appendix C, C-1
 Metric equivalents, 1-18
 Missile rack:
 Replace, M901A1, 24-267
 Retainers, M901A1, replace, 24-270
 Mortar base stowage brackets:
 Replace, M1064, 24-254.1
 Replace, M106A2, 24-255
 Replace, M125A2, 24-258
 Mortar bipod stowage cover and brackets,
 M125A2, replace, 24-259

Subject, Page

M (cont)

Mortar bridge stowage brackets and bumpers, M106A2, replace, 24-256

Mortar hatch:

- Covers, M106A2, M1064, M125A2, replace, 24-113
- Exterior catches and bumpers, M106A2, M1064, M125A2, replace, 24-109
- Interior release mechanisms, M106A2, M1064, M125A2, replace, 24-107

Mortar rotator cushion rope, M106A2, replace, 24-254

Mount:

- Assembly, 7.62 MM M60 machine gun platform, M113A2, replace, 38-5
- Bracket, filter switch, M13 NBC, M577A2, replace, 39-21
- Commander's cupola machine gun:
 - Repair, M113A2, M106A2, M125A2, M1064, M1059, 24-90
- Driver's seat:
 - Old configuration, replace, 24-127
 - New configuration, replace, 24-247
- Fire extinguisher cylinder and, replace, 42-13
- Fire extinguisher, M1059, replace, 42-16
- Fire extinguisher, portable, replace, 42-15
- Front engine, replace, 4-2
- Rear armor shield mounting arm lock assembly and, replace, 38-10
- Shock absorber, replace, 22-29
- Transfer gearcase resilient, replace, 19-2
- Traversing unit and spacer, M901A1, replace, 24-275

Mount stops, commander's cupola machine gun, M1059, replace, 24-93

Mounting bracket, fuel filter, M577A2, M1068 with 200 amp gen, replace, 9-45

Mounts:

- And heaters, M13 NBC, M577A2, replace, 39-17
- Differential, replace, 21-20
- Front engine, replace, 4-2
- Facsimile machine assembly M1068, 40.1-2
- Ground lead, instrument panel, and, replace, 11-2
- Printer M1068, replace, 40.1-52

Move in any shift lever position, carrier does not, 3-177

Muffler and brackets, replace, 7-20

Subject, Page

M (cont)

Muffler extension and valve, replace, 7-18

N

Neutral start switch, replace, 23-55

Nomenclature cross reference list, 1-9

Non-skid plates, M106A2, M1064, M125A2, replace, 33-4

O

Oil:

- Can bracket, replace, 24-237
- Cooler-to-transmission hose, replace, 18-2
- Filler cap and tube, replace, 4-13
- Filler, transfer gearcase:
 - Disassemble/assemble, 19-5
 - Replace, 19-4
- Fog, tank quick disconnect to adapter access plate hose, M1059, replace, 40-31
- Gage rod and guide, replace, 4-15
- Level, dipstick, tube and guide, transfer gearcase, replace, 19-3
- Low pressure indicator fails to go off after engine starts, 3-50
- Low pressure indicator malfunctions, engine, 3-148
- Seal, final drive pinion, replace, 20-11
- Transmission, hi temp indicator malfunctions, 3-153

Operation, principles of, 2-1

Operator's seat, M1059, repair, 24-150.1

Operator's seat, M1059, replace, 24-149

Orifice connector assembly:

- NBC equipment, replace, 39-100
- Support, quick coupling half, M8A3/M13/M14, M113A2, M1059, M577A2, M1068, replace, 39-34
- Supports, quick disconnect couplings, M8A3 NBC, M106A2, M125A2, replace, 39-41

Outlet:

- Left rear utility, admittance buzzer works improperly, M577A2 and M1068, 3-125
- Right rear utility, blower does not work, M577A2, 3-122

P

Pad:

Cushioning, replace, 24-236

Subject, Page

P (cont)

Pad (cont) :
 Tow cable, replace, 24-6
 Pad and handle, commander's cupola cushioning, M113A2, M106A2, M1064, M125A2, replace, 24-78
 Pad and handle, commander's hatch cushioning, M577A2, M1068, replace, 24-95
 Panel:
 Control to adapter access plate electrical cable. assembly, smoke generator, M1059, replace, 40-16
 Driver's power plant access, replace, 24-25
 Indicator lights, replace, 11-5
 Instrument:
 Gages, replace, 11-11
 Mounts and ground lead, replace, 11-2
 On-off switches, replace, 11-7
 Warning lights, replace, 11-22
 Panel assembly:
 Master switch:
 Early slave receptacle, all except M577A2, replace, 9-19
 Late slave receptacle, all except M577A2, M1068, replace, 9-16
 Replace, M577A2, M1068 9-22
 Smoke generator, control, M1059, 40-9
 Panels, power plant rear access, M113A2, M901A1, replace, 24-27
 Parts:
 Filler cap and strainer:
 M125A2, M106A2, replace, 6-78
 M1059, M113A2, M577A2, M901A1, replace, 6-8
 M577A2, M1068, replace, 6-52
 M981, M1064, replace, 6-30
 Pedal:
 Assembly, upper accelerator, replace, 23-23
 Lower accelerator, replace, 23-22
 Periscope:
 Guard, driver's hatch, replace, 24-57
 Infrared, works improperly, 3-112
 Quick release assembly, driver's hatch:
 Repair, 24-57
 Stowage box:
 Replace, M106A2, M1064, M125A2, 24-250
 Spare IR (M19) 24-239
 Personnel heater malfunctions, 3-207
 Personnel seats:
 Backrests, cushions, and straps:

Subject, Page

P (cont)

Personnel seats (cont):
 Replace, M106A2, M1064, M125A2, 24-167
 Replace, M113A2, 24-163
 Cushions and straps, M577A2, M1068, replace, 24-165
 Pin:
 Multiple, and socket identification, 14-2
 Shock absorber, replace, 22-28
 Pintle socket, rear gun, M113A2, replace, 38-6
 Pintle, towing:
 Repair/Replace, 24-4
 Pipes:
 Bilge Pump:
 Front, replace, 16-5
 Rear, replace, 16-11
 Coolant heater exhaust elbow and, replace, 32-41
 Exhaust, replace, 7-16
 Heater air intake and exhaust:
 Replace, all except M106A2, M125A2, 29-53
 Replace, M106A2, M1064, M125A2, 29-55
 Pivot steer:
 Bellcranks and brackets, replace, 23-64
 Brake disk, replace, 23-71
 Brakes, hoses, tubes and fittings:
 Repair, 23-68
 Replace, 23-68
 Handles and links, replace, 23-62
 Linkage, adjust, 23-72
 Master cylinders and hoses, replace, 23-66
 System, bleed, 23-61
 Plate, and base, guard, replace, M113A2, M901A1, M1059, 27-2
 Plates, non-skid, M106A2, M1064, M125A2, replace, 33-4
 Plates, tiedown M1068, replace, 24-236.1
 Platform, commander's:
 And post, M577A2, M1068:
 Repair, 24-157
 Replace, 24-157
 Repair, M577A2, 24-153
 Replace, 24-153
 Plug, smoke generator fuel tank, M1059, replace, 40-23
 Plugs:
 Box beam, replace, 24-35
 Drain, M981A1, M1064, replace, 25-41
 Final drive, hull, replace, 24-34

Subject, Page

P (cont)

Plugs (cont):
 Hull drain, replace, 24-34
 Post, commander's seat and:
 Replace, 24-140
 Replace, M106A2, M125A2, M1064, 24-142
 Repair, M113A2, M125A2, M106A2, M1064, 24-145
 Post assembly:
 Driver's seat:
 Repair, new configuration, 24-135
 Replace, new configuration, 24-135
 Repair, M113A2, 24-135
 Replace, M113A2, 24-135
 Power:
 Cable, M577A2, M1068, repair, 14-11
 Cable harness, M3 NBC, M106A2, M125A2, replace, 39-54
 Engine disconnect, 23-57
 Engine runs rough, stabs or doesn't put out full, 3-44
 Power plant:
 Access cover, bottom, replace, 24-32
 Access panel:
 Driver's, replace, 24-25
 Rear, all except M577A2, M106A2, M125A2, replace, 24-27
 Rear, M577A2, M106A2, M125A2, M1068, M1064, replace, 24-29
 Rear, M1059, replace, 24-28.1
 Door:
 Combat lock, replace, 24-19
 Replace, 24-21
 Repair, 24-22
 Grill:
 Entry panel, M1068, repair, 40.1-24
 Support arm, replace, 24-50
 Raise/lower, 5-2
 Remove and install, 5-11
 Rear access panel:
 Replace, all except M577A2, M106A2, M125A2, 24-27
 Replace, M577A2, M106A2, M125A2, M1068, M1064, 24-29
 Power supply:
 Assembly, infrared, replace, 12-134
 Cable assembly, smoke generator, M1059, replace, 40-11
 Shock mount brackets, infrared, replace, 12-136

Subject, Page

P (cont)

Preparation for storage or shipment, 1-8
 Pressure indicator fails to go off after engine starts, 3-50
 Pressure relief valve:
 Hose, ramp pump to, replace, 28-9
 Tube, ramp pump to, replace, 28-28
 Preventive maintenance checks and services, 2-39
 Principals of operation, 2-1
 Printer mount M1068, replace, 40.1-52
 Pulley and access cover, fan drive, replace, 8-41
 Pulley drive shaft, bearing and housing, replace, 8-46
 Pulley and belts, idler, replace, 8-9
 Pulleys, wire rope and:
 Replace, all except M106A2, M1064, M125A2, 25-30
 Replace, M106A2, M1064, M125A2, 25-31
 Pulleys/belts, engine coolant pump idler, replace, 8-9
 Pump:
 Circuit breakers, bilge, replace, 16-12
 Coolant heater, replace, 32-54
 Coolant heater fuel:
 Replace, M106A2, M125A2, 32-14
 Replace, M113A2, M901A1, M1059, 32-12
 Replace, M577A2, M1068, 32-16
 Differential oil, replace, 21-2
 Engine coolant, replace, 8-11
 Engine fuel, replace, 6-121
 Fog oil:
 Assembly, M1059, replace, 40-21
 Electrical cable assembly, M1059, replace, 40-14
 Pipes:
 Front bilge, replace, 16-5
 Rear bilge, replace, 16-11
 Ramp, replace, 28-81
 Pump and strainer:
 Front bilge, replace, 16-2
 Rear bilge, replace, 16-8
 Pump to bulkhead connection hose, fuel, replace: M106A2, M1064, M125A2, 29-31

Q

R

Rack:
 Ammunition stowage, M901A1, replace, 24-266

Subject, Page

R (cont)

Rack (cont) :

- Base, left side, M1068 replace, 24-244.5
- Base, right side, M1068, replace, 24-244.3
- Horizontal ammunition:
 - Repair, M1064, 24-190.3
 - Replace, M106A2, 24-191
 - Replace, M125A2, 24-189
 - Replace, M1064, 24-190.3
- Rifle, M1064, replace, 24-160.1
- Missile:
 - Replace, M901A1, 24-267
 - Retainers, M901A1, replace, 24-270
- Radio stowage:
 - Left bulkhead, M577A2, M1068, replace, 24-245
 - Replace, M125A2, M1064, M106A2, 24-249
 - Right front, M577A2, replace, 24-242
 - Right front, M1068 replace, 24-242.1
- Vertical ammunition, M106A2, M125A2, replace, 24-188
- Vertical ammunition, M1064, replace, 24-190.1
- Vertical fuze, M106A2, replace, 24-186
- Wall, stowage, M577A2, replace, 24-243
- Radiac wire harness, M113A2, M577A2, M1068, replace, 17-13
- Radiator:
 - Access door:
 - Replace, 8-27
 - Seal and fasteners, replace, 8-25
 - Clean, 8-7,
 - Deaeration elbow to inlet elbow coolant tube, 8-12,
 - Outlet elbow to coolant pump elbow hose and tube, 8-14,
 - Parts, and, replace, 8-20
- Radio(s) does not work, 3-116
- Radio stowage rack:
 - Left bulkhead, M577A2, M1063 replace, 24-245
 - M106A2, M1064, M125A2, replace, 24-249
 - Right front, M577A2, replace, 24-242
 - Right front, M1068 replace, 24-242.1
- Ramp:
 - Access door stop bracket, M981A1, M1064, replace, 25-40
 - Bracket, M981A1, M1064, replace, 25-39
 - Control valve:
 - And fittings, all, replace, 28-84

Subject, Page

R (cont)

Ramp (cont):

- To bulkhead connection tube, replace, 28-22
- To hydraulic tank hose, replace, 28-13
- Tube, quick disconnect to, replace, 28-22
- Cylinder:
 - Breather hose on, all except M106A2, M1064, M125A2, replace, 28-91
 - Breather hose on, M106A2, 1064, M125A2, replace, 28-92
 - Bulkhead connection hose, replace, 28-89
 - Replace, 28-93
- Door:
 - Handles, replace, 25-34
 - Hook and spring, all except M981A1, M1064, replace, 25-33
 - Hook and spring, M1981A1, M1064, replace, 25-32.1
 - Seal, replace, 25-32
 - Switch, and mount, M577A2, M1068, replace, 12-74
- Inoperable/unsafe, raise/lower, 28-3
- Inoperable/unsafe M1068 raise/lower, 28-4
- Linkage:
 - Replace, M113A2, M901A1, M1059, 25-7
 - Replace, M577A2, M1068, 25-26
 - Replace, M106A2, M1064, M125A2, 25-15
- Lock:
 - Adjust, M113A2, M901A1, M1059, 25-2
 - Adjust, M577A2, M1068, 25-19
 - Adjust, M106A2, M1064, M125A2, 25-10
- Lock lever and arms, replace, M113A2, M901, M1059, 25-5
- Lock lever and cable, M577A2, M1068, replace, 25-23
- Operation is slow or sluggish, 3-184
- Pump:
 - Replace, 28-81
 - To hydraulic tank strainer tube, replace, 28-7
 - To pressure relief valve hose, replace, 28-9
- Seal, replace, 25-36
- Schematic, hydraulic system, 3-188
- Vision port:
 - Replace, M901A1, 25-37
 - Shield, M901A1, replace, 25-37
- Will not lower, 3-182
- Will not raise or free falls, 3-185
- Range selector:
 - Linkage, replace, 23-55

Subject, Page

R (cont)

Range selector (cont):
 Trans, repair, 23-50
 Trans, replace, 23-48
 Rear armor shields, M113A2, replace, 38-8
 Rear armor shield mounting arm lock assembly and mount, M113A2, replace, 38-10
 Rear compartment:
 Air ventilator, replace, 24-117
 Floor plates, M113A2, M577A2, replace, 24-36
 Receipt of material, service upon, 2-24
 Receptacle:
 Auxiliary power (slave):
 Replace, all except M577A2, M1068, 9-2
 Replace, M577A2, M1068, 9-6
 Replace, NATO, M577A2, M1068, 9-10
 Circuit breakers, rear utility, M577A2, M1068, 17-11
 Radiac wiring harness, M113A2, M577A2, M1068, replace, 17-13
 Repair, 14-7
 Utility outlet:
 Lead assembly, M577A2, M1068, replace, 17-7
 Rear, M577A2, M1068, replace, 17-9
 Replace, all except M577A2, M1068, 17-5
 Recommendations (EIR), reporting of equipment improvement, 1-11
 Records, and reports, maintenance forms, 1-8
 Reel holder assembly, cable, M1064:
 Repair, 24-208.3
 Replace, 24-208.2
 References, A-1
 Regulator:
 Assembly
 100/200 amp generator, replace, 9-40
 Circuit breaker, regulator/generator, (100 amp), replace, 9-42
 Voltage:
 100/200 amp generator, adjust, 9-38
 Release, trim vane:
 Repair, 24-17
 Replace, 24-17
 Relief valve tee to quick disconnect hose, replace, 28-22
 Repair, 2-34
 Repair parts, special tools, TMDE, and support equipment, xiii

Subject, Page

R (cont)

Reports, maintenance forms, records, and, 1-8
 Restriction indicator and hose, air cleaner, replace, 7-9
 Restrictor, gun traverse, replace, 38-7
 Retainers:
 Battery and, all except M106A2, M1064, M125A2, replace, 13-16
 Battery and, M106A2, M1064, M125A2, replace, 13-18
 Missile rack, M901A1, replace, 24-270
 Rifle brackets, replace, 24-238
 Rifle rack, M1064, replace, 24-160.1
 Right forward table, M577A2, M1068, replace, 24-175
 Right rearward table, M577A2, M1068, replace, 24-173
 Right rear utility outlet/admittance buzzer does not operate, M577A2, 3-131
 Rod and guide, oil gage, replace, 4-15
 Road wheel:
 Hub, replace, 22-9
 Replace, 22-7
 Support arm, replace, 22-12
 Rope and pulleys, wire, replace:
 All except M106A2, M1064, M125A2, 25-30
 M106A2, M1064, M125A2, 25-31

S

Schematic:
 Air box heater system, 3-54
 Bilge pump system, 3-206
 Chemical agent auto alarm system, 3-236
 Electrical system:
 Indicators, all carriers, 3-171
 M577A2, additional, 3-174
 M981, additional, 3-175
 Engine charging system:
 100 amp, 3-65
 200 amp, 3-66
 200 amp, M981, 3-67
 Engine fuel system, 3-52
 Ramp hydraulic system, 3-188
 Starting system, 3-53
 Stop bracket, ramp access door, M981A, M1064, replace, 25-40
 Seal, ramp, replace, 25-36
 Seat:
 Crew, M901A1, replace, 24-169

Subject, Page

S (cont)

Seat (cont):
 Commander's:
 Jump, replace, 24-151
 M1068, repair, 24-144.2
 M1068, replace, 24-144.1
 Observation periscope, M901A1, replace, 24-161
 Driver's, all configurations, repair, 24-127
 Driver's, repair, 24-129
 Operator's, M1059, repair, 24-150.1
 Operator's, M1059, replace, 24-149
 Personnel:
 Backrests, cushions, and straps, M106A2, M1064, M125A2, replace, 24-167
 Backrests, cushions, and straps, M113A2, replace, 24-163
 Cushions and straps, M577A2, M1068, replace, 24-165
 Post assembly, driver's, new configuration:
 Repair, 24-135
 Replace, 24-135
 Station operator's, repair, 24-150.4
 Station operator's, replace, 24-150.3
 Seat and post, commander's:
 Repair, M113A2, M106A2, M125A2, M1064, 24-145
 Replace, 24-126
 Replace, M106A2, M125A2, M1064, 24-142
 Secondary filter to left cylinder head fuel hose, 6-108
 Semiannual (S) operation checks, unit preventative maintenance checks and services, 3-41
 Service:
 Headlights do not operate, 3-78
 Tail light does not operate, 3-98
 Upon receipt of material, 2-24
 Service and, infrared headlights:
 Repair, 12-3
 Replace, 12-3
 Service and/or blackout stop lights malfunction, 3-89
 Shaft:
 Final drive, left, replace, 20-5
 Final drive, right, replace, 20-7
 Trans-to-differential, replace, 20-2
 Shelf assembly, (M10681, replace, 24-244.1
 Shelf, equipment stowage, M901A1, replace, 24-180

Subject, Page

S (cont)

Shield external handle, replace:
 M106A2, M1064, M125A2, 42-4
 M113A2, M901A1, M1059, 42-2
 M577A2, M1068, 42-3
 Shield rear armor, mounting arm lock assembly and mount, replace, 38-10
 Shields:
 Commander's cupola armor, M113A2, M106A2, M125A2, M1064, M1059, replace, 38-2
 Rear armor, M113A2, replace, 38-8
 Shipment, preparation for storage or, 1-8
 Shock absorber:
 Mount, replace, 22-29
 Pin, replace, 22-28
 Replace, 22-26
 Shutoff cable, fuel:
 Adjust, 23-46
 Replace, 23-44
 Shutoff valve to fuel pump, hose, M577A2, replace, 32-6
 Side armor, M901A1, replace, 24-120
 Sight extension arm stowage brackets:
 M106A2, M125A2, replace, 24-253
 M1064, replace, 24-252.1
 Sight gage, drain cap and, replace, 8-42
 Smoke generator:
 Access plate and gasket, M1059, replace, 40-27
 Armor, M1059, replace, 40-34
 Assembly and support bracket, M1059, replace, 40-6
 Breather hose assembly, M1059, replace, 40-5
 Compressor reservoir to adapter access plate air hose, M1059, replace, 40-29
 Control panel assembly, M1059, replace, 40-9
 Fuel lines and guards, M1059, replace, 40-25
 Fuel tank plug, M1059, replace, 40-23
 Power supply, cable assembly, M1059, replace, 40-11
 Smoke grenade launcher:
 Malfunction, 3-196
 Wiring harness, M113A2, M1059, M901A1, replace, 27-2
 Socket:
 Identification, multiple pin and, 14-2
 Rear gun pintle, M113A2, replace, 38-6
 Solenoid and bracket, suspension lockout, replace, 28-74

Subject, Page

S (cont)

Solenoid valve, air box heater, replace, 6-136
 Solenoid wiring harness, suspension lockout, replace, 28-76
 Speedometer:
 Cable, repair, 11-19
 Cable and adapter, replace, 11-17
 Instrument panel, replace, 11-16
 Malfunctions, 3-227
 Stalls or does not put out full power, engine runs rough, 3-44
 Start:
 Below 40 degrees, air box heater is used, engine cranks but will not, 3-34
 Engine cranks but will not, 3-30
 Starter:
 Ground leads, replace, 10-4
 Replace, 10-2
 Station operator's seat, M1068:
 Repair, 24-150.4
 Replace, 24-150.3
 STE/ICE-R Troubleshooting 3-9
 Steering:
 Brake adjustment, 23-2
 Brakes malfunction, 3-176
 Steering levers:
 Cross-shafts, and bearings, replace, 23-10
 Cross-shafts, and links, replace, 23-14
 Left/right, repair, 23-7
 Stencils, markers, and decals, dataplates, replace, 24-217
 Stewart Warner Corp., heater component maintenance, 30-1
 Stop light switch and bracket, replace, 12-132
 Stop light-tail light:
 Left:
 Repair, 12-13
 Replace, 12-12
 Right:
 Repair, 12-13
 Replace, 12-14
 Stop light-tail light and guards, M981, M1064, replace, 12-57
 Storage box, map, M1068:
 Repair, page 24-248.3
 Replace, page 24-248.2
 Storage or shipment, preparation for, 1-8
 Stowage box:
 Grenade, M106A2, M1064, M125A2, 24-250
 Periscope, M106A2, M1064, M125A2, 24-251

Subject, Page

S (cont)

Stowage bracket:
 Launch tube, M901A1, replace, 24-271
 Mortar base:
 Replace, M106A2, 24-256
 Replace, M125A2, 24-258
 Mortar bridge, and bumper, M106A2, replace, 24-256
 Sight extension arm:
 M106A2 and M577A2, replace, 24-253
 M1064, replace, 24-252.1
 Windshield, M106A2, M1064, M577A2, replace, 24-252
 Stowage cover, and brackets, mortar bipod, M125A2, replace, 24-259
 Stowage hooks, and brackets, M113A2, replace, 35-3
 Stowage rack:
 Radio, left bulkhead, M577A2, M1068, replace, 24-245
 Radio, M106A2, M1064, M125A2, 24-249
 Radio, right front, M577A2, 24-242
 Radio, right front, M1068, 24-242.1
 Wall, M577A2, 24-243
 Strainer:
 Front bilge pump and, replace, 16-2
 Rear bilge pump and, replace, 16-8
 Parts, filler cap, M125A2, M106A2, replace, 6-78
 Straps, and tarpaulin, MM113A2, M1059, replace, 35-2
 Support, high stow, launcher, M901A1, replace, 24-124
 Support arm:
 Road wheel, replace, 22-12
 Support bracket, smoke generator assembly and, M1059, replace, 40-6
 Suppressor, MX-777B/GRC or MX-7778A/GRC, transient, replace, 41-4
 Switch:
 Admittance buzzer, M577A2, M1068, replace, 12-72
 Assembly and cables, M8A3/M14 NBC, M113A2, M1059A2, replace, 39-95
 Assembly, cables, M8A3 NBC, M106A2, M125A2, replace, 39-43
 Blower, M577A2, M1068, replace, 17-16
 Differential:
 High oil temperature, replace, 15-4
 Lead, replace, 15-5

Subject, Page

S (cont)

Switch (cont):
 Dome light:
 Bypass, M577A2, M1068, replace, 12-71
 Front, M577A2, M1068, replace, 12-68
 Bear, M577A2, M1068, replace, 12-69
 Engine:
 Coolant temperature, replace, 15-3
 Low oil pressure, replace, 15-2
 Start, replace, 11-10
 Filter assembly, M3 NBC, M106A2, M125A2, replace, 39-49
 Filter assembly, M3 NBC, M113A2 ambulance, replace, 39-83
 Filter, mount bracket, MI3 NBC, M577A2, 39-21
 Filter, mount bracket, M3 NBC, M577A2, 59-68
 Flame detector:
 Replace, 32-4
 Repair, 32-5
 Fuel quantity selector, replace, 17-17
 Fuel select, to gage lead, M981, M1064, replace, 11-20
 Generator, field, replace, 9-44
 Headlight high beam selector, replace, 12-77
 Horn, replace, 11-24
 Main light, replace, 11-9
 Master, on indicator, does not light, 3-129
 Master assembly, replace, 9-13
 Neutral, start, replace, 23-53
 Panel assembly, master:
 Early slave receptacle, all except M577A2, replace, 9-19
 Late slave receptacle, all except M577A3 and M1068, replace, 9-16
 Replace, M577A2, M1068, 9-22
 Ramp door:
 And mount, M577A2, M1068, replace, 12-74
 Stop light, and bracket, replace, 12-132
 Transmission, high oil, temperature, replace, 15-6
 Switch on indicator does not light, master, 3-129
 Switch to distribution box wire assembly (circuit 49 lead), master, M577A2, replace, 9-40
 Switch, distribution box master M1068, replace, 9-49

Subject, Page

S (cont)

Switches, instrument panel on-off, replace, 11-7

T

Table:
 Left, M577A2, M1068, replace, 24-178
 Of contents, ii
 Eight, forward, M577A2, M1068, replace, 24-175
 Eight, rearward, M577A2, M1068, replace, 24-173
 Tachometer:
 Adapter, and cable, replace, 11-14
 Instrument panel, replace, 11-13
 Malfunctions, 3-230
 Tail light does not operate, service, 3-98
 Tail lights do not operate, blackout marker lights, and/or, 3-93
 Tank:
 Auxiliary:
 And parts, replace, 8-28
 Deaeration hoses, replace, 8-32
 To coolant pump tube, replace, 8-30
 To radiator tube, replace, 8-31
 Fog oil, M1059, replace, 40-2
 Fuel:
 Replace, M981, M1064 only, 6-34
 Repair, temporary, M113A2, M1059, M901A1, M577A2, 6-21
 Replace, M577A2, M1068, 6-73
 Replace, M113A2, M901A1, M1059, 6-11
 Hydraulic:
 Repair, 28-17
 Replace, 28-15
 Strainer, replace, 28-15
 Tanks, draining:
 M113A2, M901A1, M1059, 6-5
 M577A2, M1068, 6-50
 M981, M1064, 6-28
 Tarpaulin and straps, M113A2 and M1059, replace, 35-2
 Telepost and cover, replace, 17-8
 Temperature indicator:
 Comes on, transmission oil hi, 3-71
 Malfunctions, coolant, 3-144
 Temperature switch, transmission oil high, replace, 15-6
 Tension adjuster and mount, track, replace, 22-24

Subject, Page

T (cont)

Tent:

- And clamps, M577A2, replace, 24-181
- Frame and mounts, M577A2, replace, 24-183
- Light assembly, M577A2, replace, 12-76

Terminal blocks TB1 and TB2, inverter housing, M1068, replace, 40.1-28.1

Thermostat:

- Housing and deaeration elbow, replace, 8-15
- Tube, housing to engine coolant, replace, 8-18

Throttle, hand, replace, 23-42

TMDE, and support equipment, repair parts, special tools, xiii

Tools:

- And supplements and special tools/fixtures list, common, D-1
- Fabricated, E-1
- TMDE, and support equipment, repair parts, special, xiii

Torque wrench adapters and the conversion formula, use of, 2-29

Torsion bar:

- Anchor, replace, 22-36
- Replace, 22-32

Tow cable pad, replace, 24-6

Towing hook, replace, 24-3

Towing pintle:

- Repair, 24-4
- Replace, 24-4

Towlines, repair, 35-4

Track:

- Replace, 22-4
- Shroud and covers:
 - 12 inch (30 cm), replace, 22-2
- Tension adjuster and mount, replace, 22-24

Track shoe:

- Assembly, and pad, replace, 22-6

Trailer:

- Harness, replace, 17-2
- Light receptacle wiring harness, replace, 12-18
- Lights do not operate, 3-100

Transmission hi oil temp indicator malfunctions, 3-153

Transfer gearcase:

- Disassemble/assemble, oil filler, 19-5
- Lifting eyebolt, cover, and plug, replace, 19-6
- Oil filler, replace, 19-4
- Oil level dipstick, tube, and guide, replace, 19-3

Subject, Page

T (cont)

Transfer gearcase (cont):

- Resilient mount, replace, 19-2

Transient suppressor, MX-7777B/GRC or MX7778A/GRC, M901, replace, 44-4

Transmission:

- And lower accelerator linkage:

- Repair, 23-29
- Replace, 23-25

Hi oil temperature indicator comes on, 3-71

Hose and fittings, oil cooler to, replace, 18-4

Oil filter and element, drain, replace, 18-8

Oil hi temp indicator malfunctions, 3-153

Oil high temperature switch, replace, 15-6

Range selector:

- Repair, 23-50
- Replace, 23-48

Shaft, to differential, replace, 20-2

Throttle valve linkage, and accelerator, adjust, 23-34

To oil cooler hose and fittings, replace, 18-2

Vent and filler tube, replace, 18-6

Transmitter, fuel quantity:

- Replace, M113A2, M901A1, M1059, 6-9
- Replace, M125A2, M106A2, 6-80
- Replace, M577A2, M1068, 6-54
- Replace, M981, M1064, 6-32

Traversing unit mount and spacer, M901A1, replace, 24-275

Trim vane:

Control linkage, repair, 24-13

Release:

- Repair, 24-17
- Replace, 24-14

Repair, M106A2, M125A2, M577A2, M1068, M1064, 24-9

Repair, all except M106A2, M125A2, M1064, M1068, M577A2, 24-11

Replace, 24-8

Tripod stowage brackets, M901A1, replace, 24-272

Troubleshooting, 3-8

How to use, 3-1

Tube:

Auxiliary tank:

- To coolant pump, replace, 8-30
- To radiator, replace, 8-31

Bulkhead connection to heater:

- Fuel inlet hose, 32-23
- Replace:

Subject, Page

T (cont)

- Tube (cont):
 - M113A2, M1059, 29-24
 - M106A2, M1064, M125A2, 29-33
 - M577A2, M1068, 29-40
 - Cylinder discharge, replace, 42-11
 - External cable, replace, 42-8
 - Fuel compartment-to-fuel pump, M106A2, M125A2, replace, 29-29
 - Quick disconnect to ramp control valve, replace, 28-22
 - Ramp control valve to bulkhead connection:
 - Replace, 28-22
 - Ramp pump to hydraulic tank strainer, replace, 28-7
 - Tube and hose, engine oil cooler, replace, 8-14
- Turret guard:
 - Repair, 24-210

U

- Unit preventative maintenance checks and services, semiannual (S) operation checks, 3-41
- Utility outlet:
 - Blower, left rear, does not work, M577A2, 3-125
 - Lead assembly, replace, M577A2, M1068, 17-7
- Receptacle:
 - Circuit breakers, M577A2, M1068, replace, 17-11
 - Rear, M577A2, M1068, replace, 17-9
 - Replace, all except M577A2, M1068, 17-5
- Right rear/admittance buzzer works improperly, M577A2, 3-122.

V

- Valve:
 - Air control, repair, 7-11
 - Air control cable, repair, 7-13
 - Auxiliary generator fuel shutoff, M1068, replace, 28.1-2
 - Front bilge, replace, 16-7
 - Muffler extension and, replace, 7-18
- Vanes, air pump, 6-135
- Vent and filter screen, fuel cap, M981, M1064, clean, 6-48.1
- Vent, hoses, tubes, and fittings, M577A2, M1068, replace, 6-70

Subject, Page

V (cont)

- Ventilated face mask:
 - Gas filter, M25/M25A1, replace, 39-101
 - Heater, M25/M25A1, replace, 39-102
 - Hose assembly, M25/M25A1, replace, 39-99
 - Orifice connector assembly, NBC equipment, replace, 39-100
- Vertical ammunition rack, M106A2, M125A2, replace, 24-188
- Vertical ammunition rack, M1064, replace, 24-190.1
- Vertical fuze rack, M106A2, replace, 24-186
- Vision block locks and seals:
 - Commander's hatch/cupola cover:
 - Replace, M113A2, M106A2, M1064, M125A2, 24-86
 - Replace, M577A2, M1068, 24-97
 - Driver's hatch:
 - Repair, M901A1, 24-67
 - Replace, all except M901A1, 24-62
- Vision port:
 - Ramp, M901A1, replace, 25-37
 - Ramp shield, M901A1, replace, 25-37
- Voltage regulator:
 - Adjust, 100/200 amp generator, 9-38

W

- Warnings, summary, a
- Welding, repair hull by, 26-1
- Wheel, idler, replace, 22-16
- Wheel, idler hub, replace, 22-17
- Windshield and brackets, replace, 30-2
- Windshield stowage bracket, M106A2, M1064, M125A2, replace, 24-252
- Wire rope and pulleys:
 - Replace, M106A2, M1064, M125A2, 25-31
 - Replace, all except M106A2, M1064, M125A2, 25-30
- Wiring diagrams:
 - M106A2, M125A2, FO-4
 - M113A2, FO-1, FO-2
 - M577A2, FO-3
 - M901A1, FO-6
 - M1064, FO-8
 - M1068, FO-9 thru FO-11
- Wiring harness:
 - Air box heater, replace, 6-140
 - Chemical agent, replace 44-6
 - Coolant pump-to coolant heater, replace, 32-43

Subject, Page

W (cont)

Wiring harness (cont):

- Heater, M13 NBC, M577A2, replace, 39-3
- Heater, M13 NBC, M1068, replace, 39-72
- Radiac, M113A2, M577A2, M1068, replace, 17-13
- Right headlight, replace, 12-79
- Rear main:
 - Replace, M106A2, M125A2, 12-106
 - Replace, M1064, 12-118.1

Subject, Page

W (cont)

Wiring harness (cont):

- Replace, M113A2, M1059, M901A1, 12-119
- Replace, M577A2, M1068, 12-82
- Repair, 14-3
- Smoke grenade launcher, M113A2, M1059, M901A1, replace, 27-3
- Suspension lockout, solenoid, replace, 28-76

X Y Z

By Order of the Secretary of the Army:

CARL E. VUONO
General, United States Army
Chief of Staff

Official:

WILLIAM J. MEEHAN II
Brigadier General, United States Army
The Adjutant General

Distribution:

To be distributed in accordance with DA Form 12-37-E (Block 1201) Unit maintenance requirements for
TM9-2350-261-20-2

* U.S. GOVERNMENT PRINTING OFFICE : 1993 O 342-421 (63037)

THE METRIC SYSTEM AND EQUIVALENTS

LINEAR MEASURE

1 Centimeter = 10 Millimeters = 0.01 Meters = 0.3937 Inches
 1 Meter = 100 Centimeters = 100 Millimeters = 39.37 Inches
 1 Kilometer = 1000 Meters = 0.621 Miles

SQUARE MEASURE

1 Sq Centimeter = 100 Sq Millimeters = 0.155 Sq Inches
 1 Sq Meter = 10,000 Sq Centimeters = 10.76 Sq Feet
 1 Sq Kilometer = 1,000,000 Sq Meters = 0.386 Sq Miles

WEIGHTS

1 Gram = 0.001 Kilograms = 1000 Milligrams = 0.035 Ounces
 1 Kilogram = 1000 Grams = 2.2 Lbs
 1 Metric Ton = 1000 Kilograms = 1 Megagram = 1.1 Short Tons

CUBIC MEASURE

1 Cu Centimeter = 1000 Cu Millimeters = 0.06 Cu Inches
 1 Cu Meter = 1,000,000 Cu Centimeters = 35.31 Cu Feet

LIQUID MEASURE

1 Milliliter = 0.001 Liters = 0.0338 Fluid Ounces
 1 Liter = 1000 Milliliters = 33.62 Fluid Ounces

TEMPERATURE

$5/9(^{\circ}\text{F} - 32) = ^{\circ}\text{C}$
 212° Fahrenheit is equivalent to 100° Celsius
 90° Fahrenheit is equivalent to 32.2° Celsius
 32° Fahrenheit is equivalent to 0° Celsius
 $9/5 ^{\circ}\text{C} + 32 = ^{\circ}\text{F}$

APPROXIMATE CONVERSION FACTORS

TO CHANGE	TO	MULTIPLY BY
Inches	Centimeters	2.540
Feet	Meters	0.305
Yards	Meters	0.914
Miles	Kilometers	1.609
Square Inches	Square Centimeters	6.451
Square Feet	Square Meters	0.093
Square Yards	Square Meter	0.836
Square Miles	Square Kilometers	2.590
Acme.	Square Hectometers	0.405
Cubic Feet	Cubic Meters	0.026
Cubic Yards	Cubic Meters	0.765
Fluid Ounces	Milliliters	29.573
Pints	Liters	0.473
Quarts	Liter s	0.946
Gallons	Liters	3.785
Ounce.	Grams	26.349
Pounds	Kilograms	0.454
Short Tons	Metric Tons	0.907
Inch-pounds	Centimeter-kilograms	1.152
Foot-pounds	Meter-kilogram	0.136
Pound-foot	Newton-meters	1.356
Pound-inches	Newton-meters	0.113
Pounds per Square Inch	Kilopascals	6.695
Miles per Gallon	Kilometer per Liter	0.425
Mites per Hour	Kilometers per Hour	1.609

TO CHANGE	TO	MULTIPLE BY
Centimeters	Inches	0.394
Meters	Feet	3.260
Meter s	Yards	1.094
Kilometers	Miles	0.621
Square Centimeter	Square Inches	0.155
Square Meters	Square Feet	10.764
Square Meters	Square Yards	1.196
Square Kilometers	Square Miles	0.365
Square Hectometers	Acres	2.471
Cubic Meter s	Cubic Feet	35.315
Cubic Meters	Cubic Yards	1.308
Milliliters	Fluid Ounces	0.034
Liters	Pints	2.113
Liters	Quarts	1.057
Liters	Gallons	0.264
Grins	Ounces	0.035
Kilograms	Pounds	2.205
Metric Tons	Short Tons	1.102
Centimeter-kilograms.	Inch-pounds	0.666
Meter-kilograms	Foot- pounds	7.233
Newton-meters	Pound-foot	0.736
Newton-meters	Pound-inches	8.651
Kilopascals	Pounds per Square inch.	0.145
Kilometers per Liter	Miles per Gallon	2.354
Kilometers per Hour	Miles per Hour	0.621

